

**Appendix D**

---

**Underground Route Study**



January 21, 2011

# BONNEVILLE POWER ADMINISTRATION

---

## **I-5 Transmission Corridor Project** *Underground Route Study*

*Issued Final*

*PROJECT NUMBER:*  
119864

*PROJECT CONTACT:*  
DENNIS JOHNSON  
*EMAIL:*  
DEJOHNSON@POWERENG.COM  
*PHONE:*  
(913) 338-0599



## UNDERGROUND ROUTE STUDY

PREPARED FOR: BONNEVILLE POWER ADMINISTRATION

PREPARED BY: DENNIS JOHNSON

(913) 338-0599

DEJOHNSON@POWERENG.COM

REVISION HISTORY		
DATE	REVISED BY	REVISION
07/06/10	Dennis Johnson	A
11/05/10	Dennis Johnson	B
01/21/11	Dennis Johnson	0

## TABLE OF CONTENTS

<b>1.0</b>	<b>EXECUTIVE SUMMARY .....</b>	<b>1</b>
1.1	SCOPE OF WORK .....	1
1.2	OVERVIEW OF PROJECT DESIGN .....	1
1.3	COST ESTIMATES .....	2
1.4	SUMMARY .....	2
<b>2.0</b>	<b>PROJECT DESCRIPTION .....</b>	<b>3</b>
<b>3.0</b>	<b>UNDERGROUND CABLE SYSTEMS .....</b>	<b>5</b>
3.1	EXPERIENCE .....	5
3.2	CABLE SYSTEM RATING .....	7
3.3	CONSTRUCTION METHODS .....	7
3.3.1	Open Trench .....	8
3.3.2	Trenchless Installation .....	8
3.3.3	Manholes.....	11
3.3.4	Cable Installation and Testing .....	12
3.4	LAND USE .....	13
3.5	ELECTRICAL CONSIDERATIONS .....	15
3.5.1	Reactive Compensation .....	15
3.5.2	Electric and Magnetic Fields .....	17
3.6	TRANSITION STATIONS/SUBSTATIONS.....	17
3.7	MAINTENANCE.....	18
3.7.1	System Maintenance .....	21
3.8	CABLE SYSTEM RELIABILITY .....	22
3.9	CABLE FAILURE LOCATING AND REPAIR .....	22
3.9.1	Fault Locating .....	22
3.9.2	Cable Repair .....	23
<b>4.0</b>	<b>OVERHEAD TRANSMISSION SYSTEM .....</b>	<b>24</b>
4.1	OVERHEAD EXPERIENCE.....	24
4.2	SYSTEM DESIGN.....	24
4.2.1	Conductor Size.....	24
4.2.2	Tower Type.....	24
4.2.3	Foundation Type .....	25
4.3	CONSTRUCTION METHODS .....	25
4.3.1	Conventional.....	25
4.3.2	Aerial Construction.....	26
4.3.3	Line Crossings .....	26
4.4	LAND USE .....	26
4.5	ELECTRICAL CONSIDERATIONS .....	27
4.6	MAINTENANCE.....	28
4.7	FAULT LOCATING.....	28

---

<b>5.0</b>	<b>UNDERGROUND CONCEPTUAL DESIGN .....</b>	<b>29</b>
5.1	CABLE SYSTEM DESIGN.....	30
5.1.1	Open Cut Trench Design .....	30
5.1.2	Trenchless Design.....	31
5.2	ELECTRICAL CHARACTERISTICS .....	34
5.3	MAGNETIC FIELD CALCULATIONS.....	35
5.4	SYSTEM OPERATION .....	36
<b>6.0</b>	<b>OVERHEAD CONCEPTUAL DESIGN .....</b>	<b>38</b>
6.1	FACILITIES DESIGN .....	38
6.2	CONSTRUCTABILITY .....	38
6.3	SPECIAL CONSTRUCTION AREAS .....	39
<b>7.0</b>	<b>COST ESTIMATES .....</b>	<b>40</b>
7.1	COST ESTIMATE ASSUMPTIONS .....	40
7.2	UNDERGROUND COST ESTIMATES.....	41
7.3	OVERHEAD COST ESTIMATES .....	42
7.4	COST ESTIMATES COMPARISON.....	42

APPENDIX A – ENVIRONMENTAL REPORT

APPENDIX B – DISCUSSION OF AVAILABLE UNDERGROUND CABLE SYSTEMS

## **1.0 EXECUTIVE SUMMARY**

## **1.0 EXECUTIVE SUMMARY**

### **1.1 Scope of Work**

Bonneville Power Administration (BPA) is proposing to install a new single circuit 500 kilovolt (kV) alternating current (AC) transmission line from a proposed substation near Castle Rock, Washington extending approximately 70 miles south to a proposed substation near Troutdale, Oregon. The line is being developed to proactively counter the growing demand within BPA's existing electrical transmission system in southwest Washington and northwest Oregon. To ease congestion and keep pace with these growing demands, an in depth analysis at implementing a new transmission line through the proposed project area has been undertaken to comply with the provisions of the National Environmental Policy Act (NEPA). The NEPA process is intended to promote better agency decisions by ensuring that high quality environmental information is available to agency officials and the public before the agency decides whether and how to undertake a federal action. As part of the NEPA scoping process, BPA has enlisted POWER Engineers, Inc. (POWER) to investigate the feasibility and prepare estimated costs to place the proposed transmission line underground as well as a comparative overhead line cost assessment. This report provides an overview of available underground transmission technologies, applications, and capabilities; as well as construction, operation, maintenance, repair, and estimated costs for a 500kV underground and comparable overhead line.

Narrowing the Project area to two possible routes, BPA provided both the study area as well as a number of route segments for POWER to base the feasibility study and estimates on. Additionally, BPA made available their typical estimating practices, overhead structure families, and intended operation of the line to assist POWER in its work.

To minimize the overall scope of design work, the underground portion of the study focuses solely on high voltage extruded dielectric cable (HVED); namely cross-linked polyethylene (XLPE). While other cable technologies do exist, the current US trend is to utilize XLPE cable because of its favorable traits in reliability, constructability, and long term operation and maintenance.

### **1.2 Overview of Project Design**

The basis of the underground design and installation is developed from the target power transfer requirement, from which a cable size and the total number of cables can be determined using predetermined environmental and system operating characteristics. For the anticipated underground project, it is assumed that four cables per phase will be required which will be installed in four independent concrete encased duct banks. The duct banks would be installed via open-cut trench and backfilled with thermally corrective fill to improve cable operating performance. A number of major waterways, railroad tracks and roadways would be encountered along each evaluated route. It has been assumed that major waterways and wetlands would be crossed using horizontal directional drilling (HDD) and major roadways would be crossed by means of a jack and bore (J&B). Reactor stations would be installed at two intermediate points, approximately every 25 miles and at each end.

The assumption for the overhead estimate is standard 500kV lattice tower construction according to BPA standards.



### 1.3 Cost Estimates

Using the predefined route segments, estimated costs for each route were developed taking into account the environmental conditions, geology, and anticipated construction method. Detailed assumptions have been included in Section 7 of this report. The estimated installed costs for the proposed transmission line for each route can be seen in Table 1-1.

TABLE 1-1 COMPARISON COST ESTIMATES

Route/Installation	Length (mi)	Overhead Cost	Underground Cost
Eastern Route	76	\$151,215,000	\$2,369,721,000
Western Route	68.5	\$147,080,000	\$2,051,490,000

### 1.4 Summary

While installing an underground 500kV transmission line of the proposed length appears to be technically feasible, there is a significant cost increase compared to the overhead alternative of nearly 15 times. In addition to the cost, there are significant operational, system loss, performance and reliability concerns.

- Operational Concerns – With the addition of the capacitance and reactors, BPA will need to do an extensive system analysis to determine the operational impact to their system. It may require replacement of downstream equipment as well.
- System Losses – No analysis was performed to determine the additional system losses associated with the underground cable system compared with an overhead line. However, it is well understood that the systems losses for the underground system will be significantly higher than the overhead.
- Performance and Reliability – With only a few land installations throughout the world, totaling less than 30 circuit miles, the cable and accessories have not proven themselves to maintain the high reliability demands of today’s electric grids.

While a direct current (DC) cable system was not evaluated for this report, recent studies have shown that for lengths greater than 40 miles, the cost of the DC converters and DC cable system would be equivalent and may be less expensive compared to the proposed AC cable system.

## **2.0 PROJECT DESCRIPTION**

## 2.0 PROJECT DESCRIPTION

Bonneville Power Administration (BPA) is proposing to install a new single circuit 500 kilovolt (kV) alternating current (AC) transmission line from a proposed substation near Castle Rock, Washington extending approximately 70 miles south to a proposed substation near Troutdale, Oregon. The line is being developed to proactively counter the growing demand within BPA's existing electrical transmission system in southwest Washington and northwest Oregon. To ease congestion and keep pace with these growing demands, an in depth analysis at implementing a new transmission line through the proposed project area has been under taken to comply with the provisions of the National Environmental Policy Act (NEPA). The NEPA process is intended to promote better agency decisions by ensuring that high quality environmental information is available to agency officials and the public before the agency decides whether and how to undertake a federal action. As part of the NEPA scoping process, BPA has enlisted POWER Engineers, Inc. (POWER) to investigate the feasibility and prepare estimated costs to place the proposed transmission line underground as well as a comparative overhead line cost assessment. This report provides an overview of available underground transmission technologies, applications, and capabilities; as well as construction, operation, maintenance, repair, and estimated costs for a 500kV underground and comparable overhead line.

Appendix A provides a discussion of the potential environmental impacts from construction, operation, and maintenance of an overhead and underground 500kV transmission line. A description of the types of environmental resources which may be impacted by a new transmission line is provided, followed by a discussion of potential environmental impacts which may occur to these resources. The environmental impacts which are presented are general impacts and they do not relate to a specific project, location, or project proponent. Therefore, the environmental impacts and associated mitigation measures in the report may or may not apply to any particular project, including this proposed 500kV project.

Narrowing the Project area to two possible routes, BPA provided both the study area as well as a number of route segments for POWER to base the feasibility study and estimates on. These routes are comprised of a number of different route segments. The studied routes and associated route segments are:

- Eastern Route – This route length would be approximately 76 miles. This route would be made up of the following segments: A, F, I, K, W, O, Q, S, 49, 51, 52
- Western Route – This route length would be approximately 68.5 miles. This route would be made up of the following segments: 2, 4, 9, 25, 36, 41, 45, 50, 52

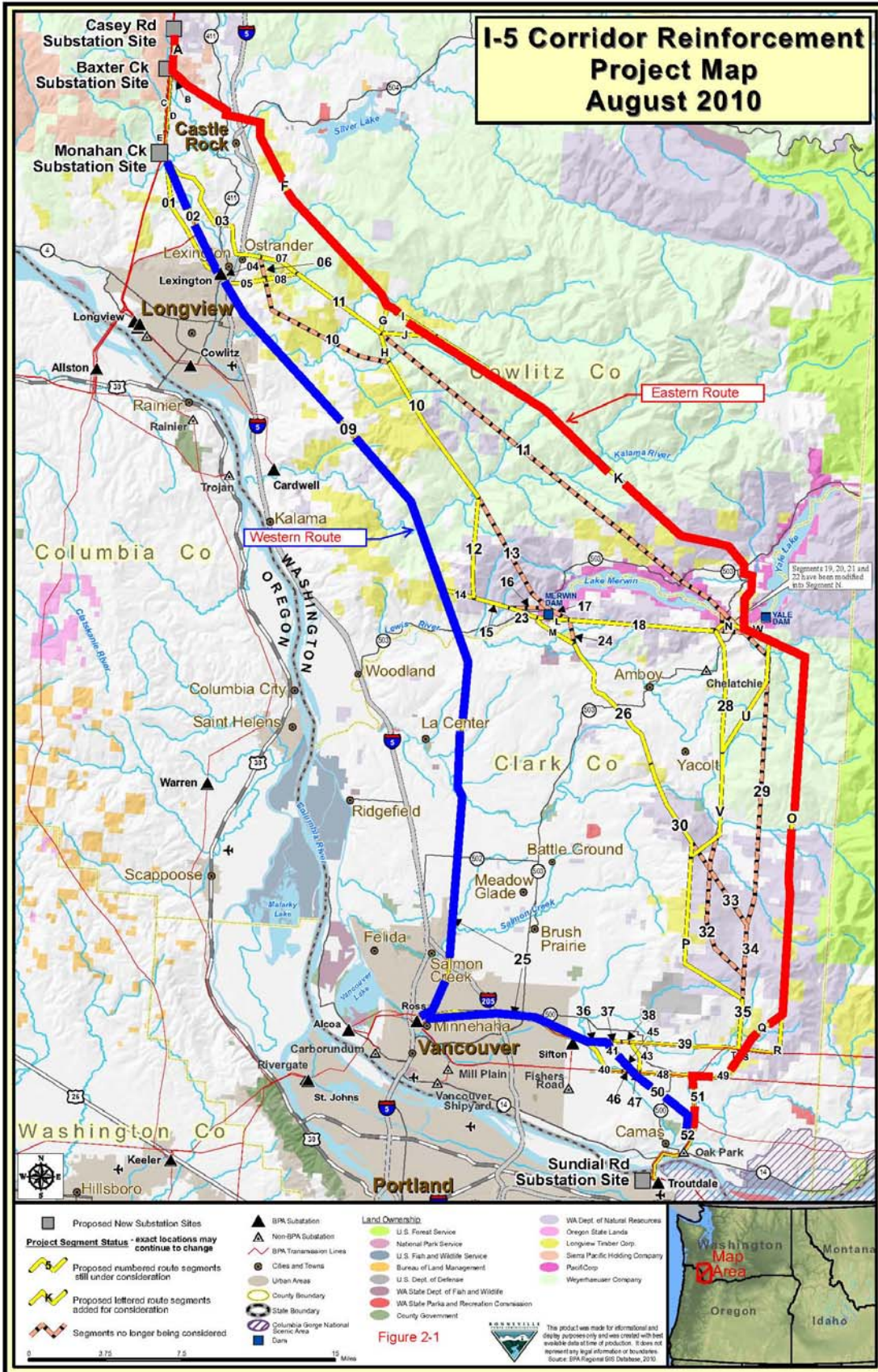

### **3.0 UNDERGROUND CABLE SYSTEMS**

### 3.0 UNDERGROUND CABLE SYSTEMS

Today, primarily two types of underground cable systems are being installed at the 500kV AC voltage level worldwide. They are:

- High Voltage Extruded Dielectric (HVED) cable system
- Self Contained Fluid-Filled (SCFF) cable system.

While a majority of the extra high voltage (EHV) underground cable installations worldwide are SCFF, a significant amount of HVED cable has recently been installed. As the cable manufacturing process has evolved and utilizing cross-linked polyethylene (XLPE) as the primary insulation material, HVED cable systems have largely become the preferred underground cable system for underground cable installations in the US. With the emergence of the XLPE cable technology at higher voltages, installations of SCFF cable systems have begun to decrease, as XLPE cable systems eliminate the need for continuous monitoring of fluid systems, reduced environmental tensions, and increased long-term system reliability.

While other EHV technologies, Gas Insulated Transmission Line (GITL) and High Temperature Superconducting (HTS), exists, GITL is not recommended for long distance applications and HTS cable has not been developed for use at 500kV and long length applications. Additional information on both of these systems has been included in Appendix B.

Another underground technology that could be utilized is to convert the power system to a direct current (DC) system and install a DC cable system. There are considerably more AC underground systems installed in the world compared to DC systems, simply because the later are relatively expensive in comparison. This is mainly due to the high cost of AC/DC converters to transform AC to DC and back again. However, when the length of the circuit is relatively long and the system voltage is above 230kV, a underground DC system may become economical viable compared to the equivalent AC underground system.

At the request of BPA, this report only addresses AC systems and the use of an XLPE cable system. Brief discussions of XLPE and SCFF cable systems are included in Appendix B.

### 3.1 Experience

There are a limited number of underground XLPE cable systems installed in the world at 500kV. However, there have been an increasing number of 400kV installations around the world. The highest voltage of XLPE cable installed in the US is 345kV.

The following is a list of AC underground cable installations for voltages 345kV and above.

Country	Date	Voltage (kV)	Circuit Length (miles)	Installation Type
Taiwan	2000	345	12.8	Tunnel
Korea	2003	345	12.2	Tunnel
USA	2006	345	8.6	Duct/manhole
USA	2007	345	2.4	Duct/manhole
USA	2008	345	8.1	Duct/manhole

Country	Date	Voltage (kV)	Circuit Length (miles)	Installation Type
Denmark	1997	380-400	13.2	Direct Buried
Germany	1998	380-400	7.8	Tunnel
Denmark	1999	380-400	7.5	Direct Buried
Germany	2000	380-400	6.5	Tunnel
Saudi Arabia	2000	380-400	7.0	Direct Buried
Iraq	2001	380-400	2.5	
Spain	2002	380-400	3.7	Tunnel
Abu Dhabi	2003	380-400	7.8	Direct Buried
Denmark	2004	380-400	16.8	Direct Buried/ducts
Italy	2006	380-400	10.4	Direct Buried
Spain	2004	380-400	15.9	Tunnel
UK	2005	380-400	12.8	Tunnel
UK	2005	380-400	3.4	Tunnel
Austria	2005	380-400	6.5	Direct Buried/Tunnel
Netherlands	2005	380-400	2.8	Direct Buried/ducts
Italy	2005	380-400	0.8	Direct Buried
UAE	2006	380-400	1.7	
Italy	2006	380-400	5.1	Direct Buried
UK	2007	380-400	8.3	Tunnel
Italy	2007	380-400	2.2	Direct Buried
Turkey	2007	380-400	8.2	Direct Buried
Netherlands	2007	380-400	0.9	Direct Buried/pipes
Netherlands	2008	380-400	4.9	Direct Buried
Qatar	2009	380-400	0.8	
Abu-Dhabi	2009	380-400	3.7	Direct Buried
Qatar	2009	380-400	10.2	Direct Buried
France	2009	380-400	3.1	Duct
Qatar	2010	380-400	13.7	Direct Buried
Qatar	2010	380-400	7.0	Direct Buried
Netherlands	2010	380-400	8.0	Direct Buried/pipes
Netherlands	2010	380-400	2.7	Duct
UK	2010	380-400	4.5	Direct Buried
UK	2010	380-400	6.8	Tunnel
UK	2010	380-400	1.1	Trough
Japan		500	25	Tunnel/Bridge
Russia		500	0.9	Tunnel
China		500	21.3	Tunnel

As can be seen in the above table, there has only been three installations of 500kV XLPE cable in the world and these were all installed in tunnels. There is no experience anywhere in the world with installing 500kV XLPE cable in a duct bank system. It is important to point out that the longest 500kV cable system in service is only 25 miles in length.

### 3.2 Cable System Rating

The ampacity, or current rating, of a cable is one of the most important concepts to understand when designing an underground cable system, since its calculation encompasses many aspects of the cable construction and installation. There are many factors that come into play when trying to design the optimal and most economical underground cable systems. One of the main factors is the thermal performance of the underground cable system.

There are many design parameters that must be determined to achieve optimal thermal performance, thus achieving the load transfer requirements. These considerations are as follows:

- Cable Size – increasing the cable size generally allows for an increased load transfer. However, there is a limit to the maximum conductor size that can be manufactured by the majority of the cable manufacturers. This conductor size is typically accepted to be up to 5000 kcmil for XLPE. The larger conductor sizes are typically manufactured at a significant increase in cost.
- Soil Thermal Resistivity – the ability of the heat to dissipate away from the cable is based on the thermal properties of the soil/backfill installed around the cable.
- Cable Depth – the deeper the cable is from the surface the harder it is for the surrounding soil to dissipate the heat, thus resulting in a lower ampacity. Typically, horizontal directional drill (HDD) construction requires a larger cable size.
- Cable Separation – other cables in close proximity also generate heat, thus resulting in mutual heating. Mutual heating can be reduced further by increasing the separation of the cables. However, the further the cables are separated the larger the excavation would need to be and an increase in cost would result.

### 3.3 Construction Methods

Regardless of the voltage rating, the same construction methods are used to install XLPE cable systems. As can be seen in the experience table above, the most common method of installation of EHV XLPE cable systems is by direct buried with a few being installed in tunnels or ducts. While direct buried is the most economical method for installing a XLPE cable system, the most common method used in the US is to install the cable in concrete encased ducts, commonly called a duct bank system. The reason a duct bank is the most common US installation method is the following:

- Provides mechanical protection
- Eliminates any re-excavation in the event of a cable failure.
- Easier to repair
- Short length of trench can be opened for construction activities. A direct buried system requires that the entire trench be left open in order to be able to install the cable.



In general, the most economical construction method for constructing an underground duct bank is by open cut trenching. Trenchless methods such as horizontal directional drilling (HDD) and jack and bore (J&B) are also common when open trenching is not allowed or feasible.

The following sections provide a general discussion on the construction and installation of a XLPE cable system.

### **3.3.1 Open Trench**

This consists of using excavation equipment to remove any concrete, asphalt road surface, topsoil and sub-grade material to the desired depth. The material removed is taken to an appropriate off-site location for disposal or used for fill as appropriate. Once a portion of the trench is dug, polyvinyl chloride (PVC) conduit is assembled and lowered into the trench. The area around the conduit is filled with a high strength thermally corrective concrete (3000 psi). After the concrete is installed the trench is backfilled and the site restored. Backfill materials can be clean excavated material, thermal sand and/or a thermally corrective concrete mix. Figure 3-1 shows a typical trench excavation.



**Figure 3-1: Typical Trench Excavation**

### **3.3.2 Trenchless Installation**

There are two types of trenchless methods that are commonly utilized when open trenching may not be allowed. They are: jack and bore (J&B) and horizontal directional drilling (HDD). Common areas where open trenching may not be allowed are: crossing roadways, street intersections, railroad crossings, bodies of water, wetlands and other environmentally sensitive areas.

### Jack and Bore (J&B)

The jack and boring method is commonly used for short crossings, under 400 feet, and where no bends are required. But J&B have been used for longer lengths depending on the soil conditions. A J&B installation consists of installing a casing under the obstruction and then installing the conduit inside the casing. Selection of the casing material is very important. Historically, most bores have been installed with steel casings, but there has been a trend to non-metallic casings such as high density polyethylene (HDPE), fiberglass or reinforced concrete pipe (RCP) due to the affect on ampacity.

To initiate a J&B installation, a bore pit having a minimum size of 40 feet long by 10 feet wide would be excavated to install a single casing. This bore pit is required by the boring equipment and for placing and welding 20-foot sections of casing pipe. If multiple casings are planned the bore pit may be enlarged or individual bore pits used. Also, prior to starting the boring process, a receiving pit approximately 10 feet in length is excavated for each casing on the opposite side of the crossing. Since a bore is basically at a greater depth than an open trench, the entrance and exit pits require shoring (and possibly tight sheeting) in accordance with OSHA regulations. Secondly, if the boring encounters poorly consolidated soil (soil that begins to slough or flow if unsupported after a few minutes), solid sheeting would be required to enclose the entire entrance pit, allowing only an opening for inserting and installing the casing and auger. Once the boring machine is in place, the bore begins and continues until the casing reaches the other side. Figure 3-2 shows a typical J&B set-up.

Casing sizes can vary for cable systems from 14 to 84 inches, depending upon the type of cable system, number of circuits being installed, and length of the bore. The longer the bore, the more difficult it is to control the direction of the bore and to fill the casing after the pipe/duct installation.



**Figure 3-2: Typical Jack and Bore Set-up**

### Horizontal Directional Drilling (HDD)

The HDD method is commonly used for longer crossing and where bends may be needed. A HDD installation for a HVED cable system consists of installing a casing with conduits inside or just installing the conduits in a bundle by themselves.

The HDD method consists of a process, where a small diameter pilot hole is drilled from entry to exit, followed by a reamer that is pulled back to enlarge the pilot hole. Finally, the product pipe is pulled into the enlarged hole. HDD operations have become quite popular with utilities since it eliminates the need to excavate large bore pits and the work can be performed from the surface. While this method does not require any significant pit excavation, it does require a significant area at the entry point and exit points of the drill. A typical entry point site requires an area of about 100 feet by 150 feet and an exit area of 100 feet by 100 feet. Figure 3-3 shows a typical HDD set up.



**Figure 3-3: Typical HDD Set-up**

If a casing is installed, the duct would be installed using specially designed spacers. The pipe would then be filled with a thermally approved grout. Without a casing, the conduits would be bundled together using specially designed spacers and then pulled back into the hole as a complete package.

When crossing any body of water a number of concerns arise, and generally these concerns are area specific. The main issues involve the type of body of water to be crossed, whether or not the area is environmentally sensitive, the location of any access points, environmental control, and permitting. When performing any work around bodies of water special permitting is usually required, as is an environmental impact study. In addition, extensive measures must be taken in preserving the natural water flow. This can range anywhere from erosion control to complete removal of all excavated soils. Because horizontal directional drilling uses bentonite, a clay type drilling fluid to stabilize the bore and reduce mechanical wear, concerns of frac-out into the water body arise. Frac-out, or inadvertent return of drilling lubricant, is caused when excessive drilling pressure results in drilling mud propagating toward the surface and can be a potential concern when an HDD is used under sensitive habitats, waterways, and areas of concern for cultural resources. While bentonite is non-toxic and commonly used in farming practices, benthic

invertebrates, aquatic plants, and fish and their eggs can be smothered by the fine particles if bentonite were discharged to waterways. To minimize the possibility of a frac-out requires a thorough geotechnical investigation. Prior to construction, a frac-out response plan is often required.

### 3.3.3 Manholes

Manholes are needed periodically along an underground route to facilitate cable installation, for maintenance requirements and access for future repairs. Manholes are typically spaced every 1,500 to 2,500 feet along the route. The manhole size and layout is based on the type of cable system installed. The manhole size is determined on the space required for cable pulling, splicing and supporting the cable in the manhole. For a 500 kV XLPE cable, the typical outside dimensions for each manhole would be about 10 feet wide by 35 feet long and the spacing between manholes would be about 1,300 to 1,800 depending on the cable size. Many utilities require a separate manhole for each set of cables for safety reasons. These utilities do not allow entrance to the manhole with any cables being energized. So for the purpose of this report, POWER assumed a manhole would be installed for each set of three phase cables at each splice location. During detail design specially designed manholes could be investigated that would allow multiple circuits to be installed in a single manhole and reduce the overall footprint of the manholes at each splice location.

The factors contributing to the final placement of the manholes are: allowable pulling tensions, sidewall pressure on the cable as it goes around a bend and the maximum length of cable that can be transported on a reel, based on the reels width, height and weight.

Typically the manholes are pre-cast and delivered to the site on a tractor trailer. A crane is then used to set the manhole. Figure 3-4 shows the setting of a pre-cast manhole.



**Figure 3-4: Typical Manhole Placement**

### 3.3.4 Cable Installation and Testing

Following the installation of the duct bank and manholes, the cable would be installed. Prior to installation of the cable, the conduit would be tested and cleaned by pulling a mandrel and swab through each of the ducts. A mandrel is a torpedo shaped pulling device used to ensure the conduits were installed properly and are free from any debris that may have entered the duct bank. Made of either wood or aluminum, a mandrel is pulled through each individual conduit. The mandrel is approximately 1/2" smaller than the inner diameter (ID) of the conduit being tested. If the mandrel passes through the conduit without getting stuck or showing significant scarring, the conduit passes inspection and cable can be installed. The swab, or often times referred to as a rag bundle, is commonly pulled through the conduit in conjunction with the mandrel. The swab, pulled in front of the mandrel, acts as a "pipe cleaner" to remove any loose material within the conduit.

Cable installation procedures and equipment would be based on environmental conditions, equipment and material placement and pulling requirements. The typical cable pulling setup would be to set the reel of cable at the transition structure or at one of the manholes and place the winch truck at the opposite end. The cable should always be pulled from the transition structure to the nearest manhole. Direction of pull between manholes should be determined based on the direction that results in the lowest pulling or sidewall tensions. Once all the cable is pulled into a manhole from each direction, splicing of the cable could commence. This process would be followed until all the cable has been pulled, terminated or spliced. Once this has occurred the cable would be tested. Figure 3-5 shows a typical cable reel set up.



**Figure 3-5: Typical Cable Pulling Set up**

Upon installation and termination of each cable, the cable must be tested before being placed in service. Typical testing includes a jacket integrity test using a specified DC voltage to ensure the jacket is continuous from end to end. Historically, an AC soak test would also be performed where the cable would be connected at rated voltage without load and left to “soak” for 24 hours. This enables the insulation to be stressed prior to current flow.

Recently, testing equipment has become available in the US to perform AC hi-pot and partial discharge (PD) commissioning testing similar to the tests that are performed in the factory. While this testing is becoming more common at lower transmission voltages (below 230kV), there is a limit to the voltage that can be generated and the length of the cable that can be tested. The higher the voltage requirement and the longer the length, the more costly the tests are to perform.

### **3.4 Land Use**

When routing an underground line, it is important to know the type of area and terrain that the line will be crossing.

#### Urban

Urban areas are becoming more and more congested with traffic and underground utilities. This makes the installation of a new underground transmission lines difficult. When choosing routes in urban areas for new circuits, extreme care is required to locate the existing underground facilities. The typical location for a new underground circuit in an urban area is within the road right-of-way. There is usually very little undeveloped land available that could be used for installing an underground line. Major thoroughfares should be avoided because of the large amount of traffic that would have to be controlled. The designer should be aware that a significant cost of installing circuits in urban locations is traffic control.

#### Suburban

Suburban areas, like urban areas, are becoming congested with traffic and construction activities. Schools, churches, and homes will likely be included in the route selected through suburban areas, requiring additional safety considerations during construction. These areas should be avoided, if possible. During construction, the entire road may have to be closed to provide sufficient working space for the installation of the underground cable system.

#### Rural

Rural areas are generally easier locations in which to construct underground lines because they usually have fewer existing underground utilities; however, they also lend themselves to overhead transmission lines more easily than suburban and urban areas. Since rural areas are generally undeveloped, the type of terrain the underground line must traverse is an important design consideration. The different terrains a transmission route may encounter are: flat, rolling hills, mountains, and wetlands or other large water bodies/obstructions. A disadvantage to rural areas is the possible limited accessibility to the route corridor for construction and future maintenance.

The type of terrain and soil conditions can greatly impact the cost of installing an underground cable system.

- Flat terrain – this type of terrain is the easiest type of terrain to perform open cut trenching unless there are environmentally sensitive wetlands. If open trenching of the wetland is unacceptable, HDD is typically used to cross under the wetland. Typically, a construction road is constructed along the full length of the trenching operation in rural areas to provide the necessary construction access.

- Rolling hills – this type of a terrain is also well suited for open cut trenching as long as the slope of the hills are not extreme (<10%). Extreme slopes can make open cutting a big challenge. The main challenge is to be able get all the necessary construction equipment, concrete trucks, tractor trailers, cranes, and cable reels, up and down the slopes to the necessary locations. Suitable access roads for the construction equipment are needed to get up and down the hill. These access roads can be constructed by cutting into the hill or designing some type of switch back. The type of design is predicated on the extent of the slope. While HDD could be utilized to cross a series of hills to avoid the slope issue, the issue of gaining access to each drill location is still a primary concern and may be impossible to achieve.
- Mountains – this type of terrain can be a challenge to the construction of an underground cable system. The same issues about the grade slope discussed above, applies to the mountain terrain as well. In addition, mountainous terrain, usually indicate the existence of rock. To excavate the rock, explosives may need to be used.
- Wetlands – while open cutting can be used to cross wetlands, typically, there are significant environmental controls applied to the process, which will generally significantly increase the costs. In some cases, HDD can be used to span a large wetland area.
- Large waterbodies/obstructions – there are some situations where open trenching is not practical. This situations involve crossing of large rivers, waterways, highways or railroad tracks where open cutting is not allowed.

The type of land use often determines the amount of easement or right-of-way available for the underground line. Underground lines are frequently located in existing roadway rights-of-way. Typically, no easement is required to install the underground line in public right-of-way; however, the owner of the road usually reserves the right to have the utility relocate the underground line if a future conflict occurs. For this reason, some utilities prefer to install underground circuits within a dedicated easement adjacent and parallel to the public right-of-way, and to accept the added cost. Additionally, underground lines can be installed in existing overhead line right-of-ways or in joint use easements when long cross-country inter-ties are being installed.

While typically only a 30 foot right-of-way is required for most underground projects, this project would require a larger amount of right-of-way depending on the installation method. In an attempt to minimize conductor size, each duct bank will need at least 10 foot center-to-center separation resulting in a total right-of-way width of approximately 60 feet after access and constructability is considered. Further, temporary construction easements may be required if the underground installation could not be installed within or at the edge of road right-of-way and the road right-of-way is not suitable for the set up of the installation equipment. All trees and vegetation in the permanent and temporary easements would need to be cleared for construction. All federal, state, county, city and other applicable agencies would need to be contacted to determine permitting requirements. The final decision on the amount required for right-of-way would be determined during final route selection. Figure 3-6 shows a cross section of the proposed right-of-way.

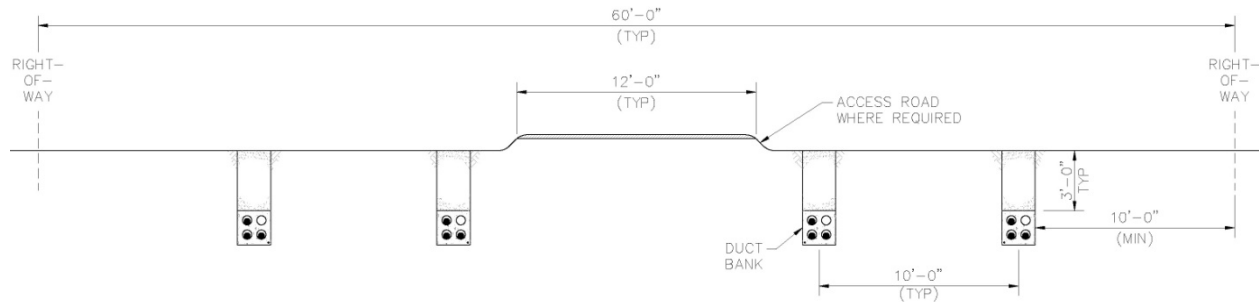

**Figure 3-6: Typical Right-of-Way Usage**

### 3.5 Electrical Considerations

The characteristics of 500 kV underground cables are significantly different from those of 500 kV overhead lines, and these differences must be taken into account when considering integrating underground cables into a transmission system composed primarily of overhead lines. The following is a list of some of the important design considerations.

- Cable reactive-compensation requirements
- Effects on power flows
- Effects on switching devices
- Effects on surge-protective devices
- Steady-state voltage effects
- Impact on system parallel harmonic resonance frequency
- Short-term overload characteristics
- Increased losses
- More complex protection scheme

An in-depth analysis of these topics requires sophisticated load-flow, transient-stability, short-circuit, and overvoltage calculation computer programs. No attempt was made to perform any system analysis. Before an underground 500 kV cable is considered further, a comprehensive system analysis should be performed to determine the impact of the underground cable system on BPA's network.

#### 3.5.1 Reactive Compensation

One significant design consideration with a 500 kV underground cable system is the amount of capacitance which would be added to BPA's system and the resulting charging current of the underground cables. The high capacitive charging current inherent in cable circuits may cause a reduction in the amount of real power that can be transmitted through a cable circuit, and may cause appreciable energy losses. As the cable circuit length is increased, the capacitance and, therefore, the charging current increase linearly. In the worst case, the magnitude of the charging current may increase until it is equal to the cable ampacity, at which point no real power may be transmitted without overheating the cable. This length is commonly called the "critical cable length." For a 500kV cable system, this critical length is about 50 miles. To allow real power to be transmitted along a 500kv cable system longer than 50 miles, intermediate reactor stations are need to control the charging current. Figure 3-7 is a graph showing where the charging current becomes equal to the capacity of the cable for a 500kV AC system.



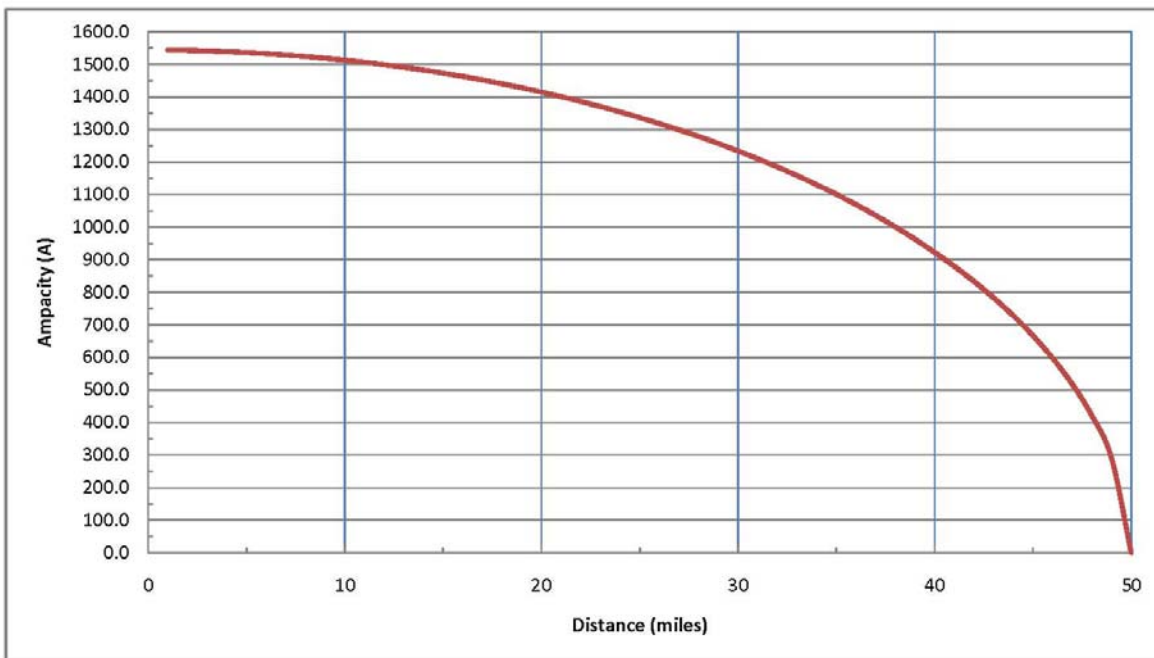

**Figure 3-7: Maximum Real Current Transfer**

In addition, most 500 kV transmission systems cannot accept the amount of capacitance that would be added to the system as a result of adding the underground cables. As a result, reactive compensation must be added to the system to mitigate this additional capacitance. Shunt reactors are often placed at one end, both ends or at intermediate locations along the route length to consume the charging current. The reactors limit the voltage rise during light-load conditions, especially where the local power system is relatively weak (high system impedances) at the cable location. The optimum amount and location of shunt compensation must be determined by running load-flow cases at different load levels and studying the effects of future system expansion. In systems having a significant amount of cables, system power factor can be influenced at light-load periods to the extent that the system could go leading if not corrected by reducing other capacitive sources.

Currently, the longest installed 500kV XLPE cable system is 25 miles. For cable systems longer than 25 miles, intermediate reactor stations should be installed to compensate for the cable charging current. For the purpose of this report, it was assumed that reactive compensation would be added at each substation and at two intermediate sites, separated by approximately 25 miles. The amount of compensation would be equivalent to 75% of the capacitance being added by the underground cables to the system.

Calculations were performed to estimate the capacitance being added to the electric system for each design option, the amount of reactive compensation needed to offset the capacitance and the resulting charging current. The results of these calculations are included in Section 5.

### 3.5.2 Electric and Magnetic Fields

Electric and magnetic field (EMF) is a term used to describe electrical and magnetic fields created by electric voltage (electric fields) and electric current (magnetic fields). Electric fields are present whenever voltage exists on an object and are not dependent on current. Similarly magnetic fields are present whenever current flows in a conductor and are not dependent on the presence of a voltage. When an object has voltage and carries current, it produces both an electric and magnetic field and this is referred to as EMF. For shielded underground cables, the electric field is entirely contained within the cable. While no electric field exists external to the cable, the term EMF is still used for underground cable, but only refers to the magnetic field.

The movement of electric charges along a conductive path is called electric current and is measured in amperes (“amps”) or (“A”). Current measures the “flow” of electricity, and the moving charges in an electric current produce a magnetic field that exerts force on other moving charges. Wires running in parallel and carrying currents in the same direction attract, while wires carrying currents in opposite directions repel. This is the principle by which electric motors generate force. Magnetic fields are measured in gauss (“G”) or tesla (“T”) (1 T = 10,000 G). Smaller fields are measured in milligauss (1 mG = 0.001 G) or microtesla (1  $\mu$ T = one-millionth of a tesla). In the United States, the milligauss is the unit most often used to measure the strength of power frequency magnetic fields.

Due to symmetry, the magnetic fields are typically the highest directly over the underground lines. However, the strength of the magnetic fields fall-off very rapidly with lateral distance from the cable system. Furthermore, the phase arrangement of the cables can be positioned to help reduce EMF fields through a cancelation effect.

One method to further decrease the magnetic field is to install the duct bank deeper or install multiple cables per phase; however, this may result in higher installation costs. While installing the duct bank deeper or installing multiple cables per phase may result in lower magnetic fields, it would not reduce the magnetic field at the transition structures.

### 3.6 Transition Stations/Substations

Because of the potential need for reactive compensation and the number of cables per circuit, special attention needs to be given to the design of the substation at each end and the intermediate reactor stations. The design of a 500 kV reactor station turns out to be similar to a large switching station. The layout and size of a reactor site would be determined by the amount of equipment that would be needed, such as disconnect switches, shunt reactors, breakers, control house, etc. Figure 3-8 shows a possible layout for an intermediate reactor station. The breaker is needed to allow the switching of the reactor during various operational scenarios.

If only a portion of the line is underground, an overhead to underground transition station with reactors would be needed. For voltages under 230kV, the overhead to underground transition is commonly accommodated on a single shaft structure; however this is typically not the case for voltages above 230kV for the following reasons:

1. Typically, multiple cables per circuit are required and cannot be accommodated on a single shaft structure.

2. The charging current for underground lines of any length is usually large (>3 amps) and cannot be broken by lifting a jumper. This means a switch is needed to be installed and many disconnect switches cannot break over 2 amperes of capacitive current. This means that breakers or other special interrupting devices would be needed to allow the utility to isolate the underground cables. With the capacitive charge, special consideration in the selection of the breakers and disconnect switches need to be made.
3. The need to apply reactive compensation to the system. While reactors could be installed at nearby substations, the best location is as close to the end of the cable as possible. The other benefit of placing the reactors near the cable is that the reactor will help in bleeding off the capacitive charge of the cable.

The design of a 500 kV transition station turns out to be similar to a small switching station. The layout and size of a transition site would be determined by the amount of equipment that would be needed, such as disconnect switches, shunt reactors, breakers, control house, etc. For this application, the transition station would consist of a single overhead take-off tower typically an A-frame structure located at one end of the yard. Disconnect switches and circuit breakers are generally installed between the overhead line and underground cables. Figure 3-9 shows the minimum size layout for a transition station with four cables per phase with a shunt reactor.

An alternative to the radial design shown, a breaker and a half or ring bus scheme could be considered. By changing the breaker scheme, each set of cables can be isolated without causing a complete outage on the line. The system could operate at a reduced capacity, if one set of cables needs to be taken out of service. This will also allow for maintenance of different station equipment, breakers, reactors, etc, without de-energizing the line.

Switches would be installed for each set of cables to allow for further isolation. It is important to note that the switches would only be operable when the charging current has been discharged from the cable. If reactors are located in the transition station, the reactor will allow the cable to discharge through the reactor more quickly.

### 3.7 Maintenance

Routine maintenance on underground cables should be performed regularly to ensure the cables would operate with uninterrupted services.

Typical major components to be checked are as follows:

1. Terminators
2. Manholes
3. Lighting Arrestors
4. Grounds (Very Important)
5. Cables
6. Right-of-Way

The method of checking the condition and maintenance of the above items involve various methods of inspection, primarily visual and performed as follows:

**Note:** Some inspections should be performed only during an outage. Use extreme caution when working around energized lines. Work should be performed per standard utility practices.

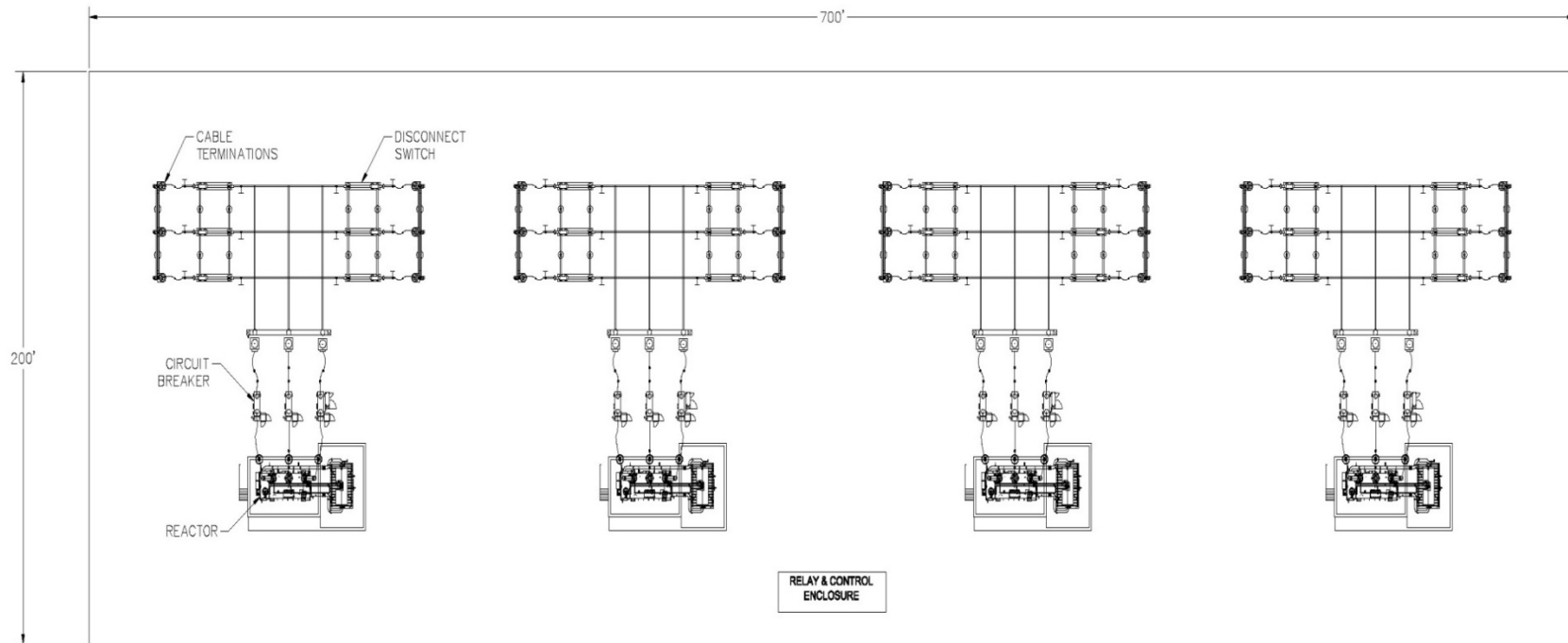

**Figure 3-8: Preliminary Reactor Station Layout**

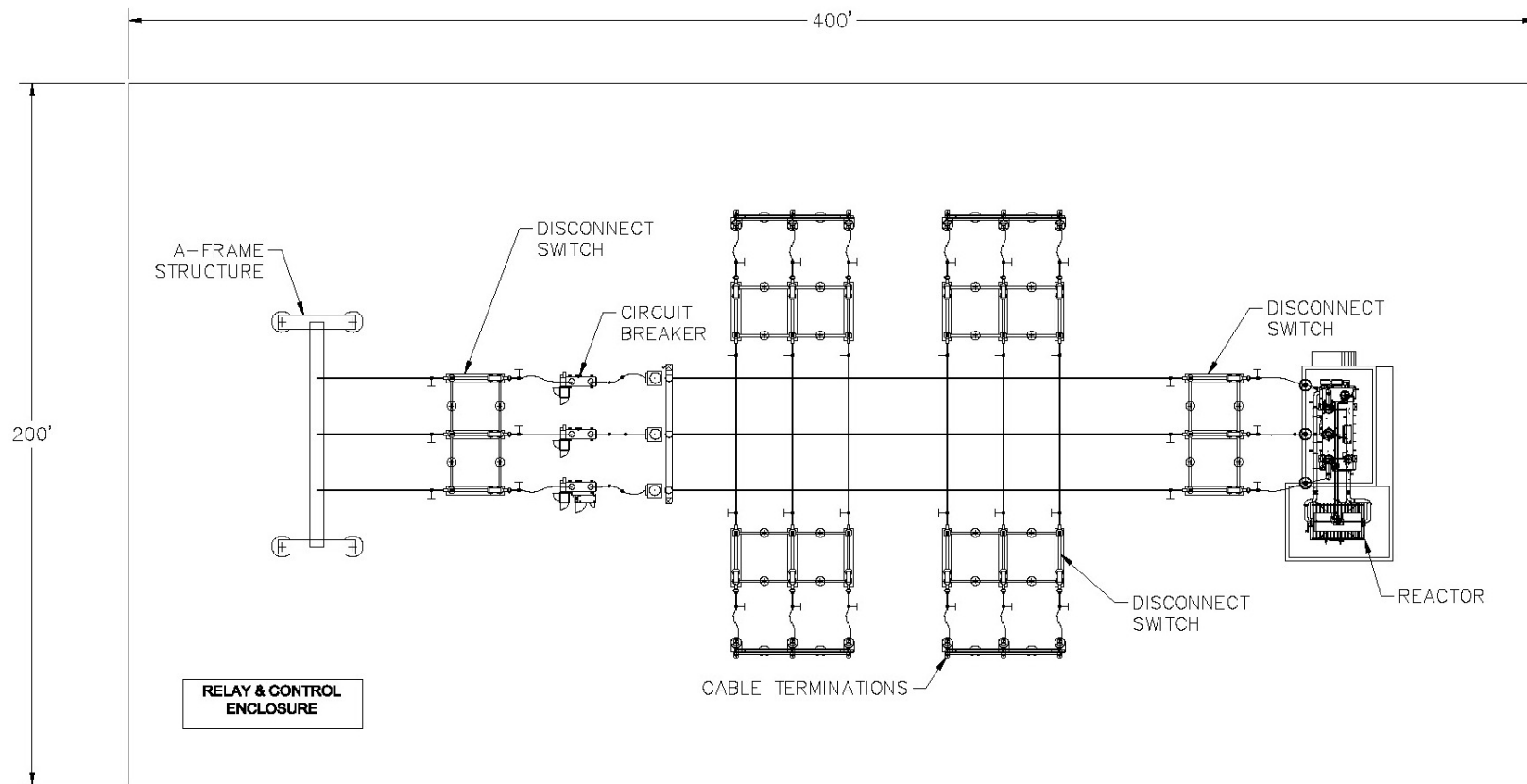

**Figure 3-9: Typical Transition Station Layout**

### **3.7.1 System Maintenance**

Routine maintenance on XLPE cables should be performed regularly every six months to a year, and scheduled around an outage.

#### Terminators

Terminators should be inspected to determine if the insulator skirts are chipped or cracked, if so, they must be repaired or replaced. Chipped or cracked porcelain must be repaired in order to prevent ingress of moisture into the terminator.

Terminators should be checked for buildup of dirt and contaminant along the skirts, or at the ferrule. In severe cases of buildup they should be wiped clean to prevent flashovers.

Visual inspection should be made for any sign of oil leaks, cracked lead wipes, damaged grounds, sagging support brackets, overheating of connections, and damaged stand-off insulators. If any of the above is found they should be repaired.

These inspections should be performed every year and do not require an outage for visual inspection.

#### Manholes

Manholes should be inspected to ensure cables are securely fastened to the brackets/clamps, and that ground connections are intact, and brackets are securely attached to the walls. It is recommended that the cable system operator pump, as practical and feasible, any water inside the manholes.

These inspections should be performed every six months or as dictated by predetermined outage windows. Additionally with multiple cables per phase, the entire system would not be required to be taken out of service but the set of cables being inspected can be removed from service and grounded, while allowing the other set of cables to remain energized and operate the line at a reduced capacity.

#### Lightning Arrestors

Lightning arrestors should be checked for signs of tracking, and chipped or cracked skirts. Verify that ground connections are tight.

These inspections should be performed every year and do not require an outage for visual inspection.

#### Grounds

Grounds should be checked that all connections are tight, non-corroded, and show no signs of overheating. Grounds should be checked for proper ground resistance. A clamp-on ammeter may be used to ensure there is no excessive current flowing through the grounds. Current should be approximately 10 amps or less.

These inspections should be performed concurrently with the inspections of terminations and splices. Any physical contact with the grounds will require an outage on the set of cables being inspected and all grounds lifted at transition sites.

#### Cables

Cables should be checked for signs of mechanical damage such as accidental dig-in or cable movement. This would ensure the cable jackets have not cracked, or been scraped/eroded due to movement.

Cables entering terminators should be securely fastened to support grips/cable cleats minimizing cable strain to the terminators.

It is recommended that a jacket integrity test be performed to verify the integrity of the jacket, if mechanical damage is suspected or in the event the cable system undergoes a severe electrical transient condition. Lightning strikes and line-to-line or line-to-ground faults on connected above ground facilities are examples of unusual or severe transients.

These inspections should be performed every six months and the jacket integrity test every year. The entire system would not be required to be taken out of service but the set of cables being inspected would need to be isolated from the rest of the system during inspection and testing.

### **3.8 Cable System Reliability**

Because of the limited number of world-wide installation at 500kV, the reliability of these systems has not been proven. While manufacturer type tests have shown that these systems are sustainable, actual real world data over an extended time period is not available to provide profound evidence of the tests. This lack of reliable evidence has laid the ground works for most projects to continue to be installed as overhead lines or at reduced voltages. However, as the technology progresses and the number of cable installations increases it is believed that XLPE cable systems will become more predominate at the 500kV level for short lengths.

### **3.9 Cable Failure Locating and Repair**

In general, an underground transmission cable system is very reliable. The main reliability issue with an underground cable circuit compared to an overhead circuit is the length of the outage in the event of a circuit failure. With an overhead circuit, the line can generally be placed back into service in a relatively short amount of time, typically less than a day, thus increasing the circuit's availability for transmitting load. When there is a fault on an underground line, the line may be out of service for a significant amount of time, generally more than two weeks and up to 6 months, depending on the type of failure and how quickly it can be located and repaired. Because of these longer outage times an underground circuit has a lower circuit availability compared to an overhead circuit.

#### **3.9.1 Fault Locating**

One of the essential steps in repairing an underground cable failure is to accurately locate the cable failure. Locating a fault on an overhead line is relatively easy, but since an underground line is out of site specialized fault locating methods are needed. Faults can be located the same day technicians arrive on site, but may take up to a week or more depending on the type of fault, type of fault locating equipment and experience of the personnel operating the equipment.

The most common method of locating the fault location is to apply a capacitor discharge (thumper) signal and then detect the return signal using an acoustical/magnetic device.

The following sequence outlines the fault locating procedures:

1. The first step is to determine if the circuit fault occurred in the overhead or underground section of the line. This can be done by investigating the status of relaying after the event provided relaying equipment has been installed to monitor the underground segment independently of the overhead section of line. If this monitoring is not installed, the utility would need to drive the line to find evidence of a fault in the overhead or underground sections. The cable should be tested even if the fault is determined to be in the overhead section of the line.
2. Once it is determined the fault is in the underground section, the location of the failure needs to be determined. The primary cause of a cable fault may lead repair crews to the location as would be the case when the fault is due to a dig-in. Terminations and splices are common fault locations and should be visually inspected prior to assuming the fault is in the cable. If visual inspections fail to locate the failure, it can be assumed the fault is somewhere in the cable and special equipment is needed to locate the fault.
3. Two common methods for locating underground faults are the thumping method or VLF (very low frequency) detection. Both methods take specialized equipment. Utilities without substantial underground cable infrastructure typically contract with specialists to locate the fault.

### **3.9.2 Cable Repair**

Once the fault is located in an XLPE cable, a special contractor would be needed to make the necessary repairs. This special contractor may be the cable manufacturer. The type of failure would determine the material needed to repair the faulted cable. This could mean having to install additional manholes, repair a damaged splice or termination, remove damaged cable and install a new cable. If multiple cables are damaged, new cable may need to be purchased.

The time required to repair a cable depends to a great extent on cable type and failure location. Failures can be repaired in only a few days but can take several months when new cable or accessories are needed.



## **4.0 OVERHEAD TRANSMISSION SYSTEM**

## **4.0 OVERHEAD TRANSMISSION SYSTEM**

Constructing an overhead transmission line at 500kV is very common in the US, particularly in the Northwestern United States. BPA, PacifiCorp, Northwestern Energy, and Pacific Gas and Electric all have extensive 500kV networks in the northwestern United States. The line construction presents particular challenges as the lines are generally routed long distances and in remote, non-traveled territory. Over the years techniques have been developed to efficiently construct these lines. In addition, there is significant history to effectively estimate cost and schedule for these lines.

### **4.1 Overhead Experience**

EHV (greater than 230 kV) transmission line construction is prevalent throughout the United States and many operating and maintenance groups are in place. Because of this, the operation of these lines has a strong history and consistently strong performance. BPA is the foremost owner of 500kV facilities in the Northwest with over 4,700 miles of lines in service.

### **4.2 System Design**

Typical power transfer ratings for 500kV lines are between 1,200 and 1,800MW. As opposed to underground lines, the limiting factor for the rating of a 500kV overhead line is generally not thermal related but is governed by electrical issues, such as impedance, corona, electrical noise, and conductor losses. This generally drives these systems to have three and sometimes four bundle conductor configurations. The thermal rating of these conductor systems are typically 2-3 times the rating of the transmission line. The resulting loadings and clearance requirements require heavy structural systems to support them – typically steel latticed towers.

#### **4.2.1 Conductor Size**

The conductor system design considers two primary electrical parameters – corona effects and fields effects. Corona is the ionization of the air that occurs at the surface of the energized conductor and suspension hardware because of high electric field strength at the surface of the metal during certain conditions. Corona may result in radio and television reception interference, audible noise, light, and production of ozone. Field effects are the voltages and currents that may be induced in nearby conducting objects. A transmission line's inherent electric and magnetic fields cause these effects. Depending on design requirements for these effects, they may have an impact on the conductor system design.

In addition, a line design study is typically performed that compares initial construction cost for various conductor systems against conductor losses for expected electrical loadings over the life of the line. An optimum conductor size is then selected based on this analysis. The conductor system is selected that considers these factors as well as utility standards.

#### **4.2.2 Tower Type**

Because of the large conductor systems – typically 3 or 4 bundle – the structural systems necessary to support them are typically steel latticed towers. Lattice towers are the most efficient structural systems to resist structural loads from the conductor systems. In some instances, public sentiment may favor the use of tubular steel poles, either in a single pole or H-framed configuration. Steel poles often have a “cleaner” look that appeals to the public. Poles have a higher installed cost than lattice towers.

Lattice towers can be broken into two categories – self-supporting and guyed types. Guyed towers utilize guy and anchor assemblies to support the loadings on the towers. Self supporting towers are four legged towers that utilize four foundations for resisting the loadings on the tower. Guyed lattice towers are typically less expensive to install. There is some concern by utilities with the history of vandalism on guyed tower lines. Self supporting towers are the most popular tower type for EHV lines.

### **4.2.3 Foundation Type**

Foundations for self-supporting towers and center points of guyed towers utilize two typical designs. The first and most popular is a drilled pier foundation. A drilled pier is a cylindrical reinforced concrete element that is poured in-situ to a round excavated hole. The second type of foundation is a grillage type. This is a mat type foundation constructed of lattice steel material extending from the bottom of the tower to a series of horizontal members in a square or rectangular pattern in the ground to a designed depth.

Typical drilled pier sizes are diameters 3 to 5 feet and depths of 15 to 35 feet. Grillage are typically 5 feet by 5 feet (tangents) up to 12 feet by 12 feet (deadends) with depths from 8 to 15 feet. The advantages of grillage foundations are that construction can occur without concrete. The access roads required for concrete trucks are generally much more extensive than for other construction equipment. Particularly in mountainous terrain, the impact of bringing concrete to site can be very expensive compared to not using concrete, or using grillage foundations. Generally, a grillage foundation is a more expensive foundation than a drilled pier, if access isn't taken into account.

## **4.3 Construction Methods**

As previously stated, the construction industry is relatively mature for 500kV transmission lines. The primary issue that impacts construction cost and schedule is accessibility of the line. With increasing environmental restrictions, aerial construction is becoming more common.

### **4.3.1 Conventional**

Typical overhead line construction for a transmission line generally follows the following sequence –

- Clearing and Access Development
- Foundation Installation
- Tower Haul and delivery
- Tower assembly
- Tower erection
- Conductor string, sag, and clip-in.
- ROW Cleanup and Restoration

For conventional construction, the key to all of these activities is the access system to the tower sites. In particular, access roads for concrete vehicles take a more robust road than grillage type foundations which only require a road for backhoe or excavator access and steel material delivery.

For mountainous terrain, access becomes a significant factor of cost as construction equipment have limits to incline, which consequently requires longer and more expensive roads and longer trips between towers.

### **4.3.2 Aerial Construction**

As noted, with the maturity of the construction trade, most overhead transmission projects utilize helicopters for the line construction. The most common use of a helicopter is for stringing of the conductor. Stringing involves using a small helicopter to pull a rope into stringing dolleys, which is then attached to a high strength pulling cable which is eventually attached to the conductor. In addition, these small helicopters are utilized to transport workers between working sites.

For environmental or accessibility reasons, some areas of lines may require aerial construction for more than stringing reasons. Towers and foundations will sometimes be constructed with aerial techniques. The helicopters necessarily are larger and more expensive to haul materials and sometimes equipment to the tower sites to perform the construction. These techniques are almost always more expensive than conventional construction and only used by a contractor when required.

### **4.3.3 Line Crossings**

The number of overhead line crossings will have an impact on the level of production for transmission line construction. These line crossings will have temporary facilities known as guard structures built on each side of these crossings. The process of pulling conductor into place will be slowed based on the criticality of these crossings and impacts they could have.

Guard structures will also be built over roads and railroads. For particularly wide highways, a specific guard structure configuration that creates a net above the road may be required to protect traffic from the stringing operations during construction in case the conductor were lost during the stringing work. In addition to the crossing fixtures associated with this work, traffic control procedures may be required during these operations.

## **4.4 Land Use**

Overhead transmission line construction is impacted by the type of terrain it crosses. As noted earlier, accessibility significantly impacts the line construction process. Primary terrain types that impact EHV lines include mountainous, rural, urban, and agricultural. In urban and agricultural properties, local officials or property owners will prefer a smaller footprint tower than a lattice tower – typically a single steel pole type.

For agricultural properties, the irrigation systems, typically center pivot sprinkler systems, require coordination with the farmers on the route alignment, structure type, and structure placement.

### **Rural**

As noted, access for equipment is the primary factor in construction conditions. As such, rural areas may present easier locations for line construction. Safety and traffic control concerns are the primary factors that favor rural over urban construction. Since rural areas are generally undeveloped, the type of terrain the transmission line must traverse is important to construction. As noted in the underground section of this report, the different terrains a transmission route may encounter include flat, rolling hills, mountains, agricultural, and wetlands or other large water bodies/obstructions. A disadvantage to rural areas is the possible limited accessibility to the route corridor for construction and future maintenance.

The type of terrain and soil conditions will greatly impact the cost of installing an overhead transmission line.

- Flat terrain – This type of terrain is the easiest type of terrain to perform overhead line construction. The ground type, e.g. rock, sand, silty, etc., will have a large impact on the ease and cost of construction. Typically, a construction road is constructed along the full length of the line to allow for access along the line right-of-way during the many phases of the construction project.
- Rolling hills – For slopes less than 10%, similar access to flat terrain is typical as most construction equipment is sufficient to utilize this type of road.
- Mountainous – For higher slope access, access roads will necessarily be longer, more difficult to construct and traverse, slowing construction. Depending on the severity of terrain, a construction contractor may choose to perform construction without access and utilize aerial techniques.
- Agricultural – Many lines are routed through agricultural properties that require coordination with farmers on route and structure location, and center pivot grounding mitigation.
- Wetlands, water bodies– These areas of construction are difficult access and construction areas as well as potential helicopter construction areas. For large water crossing, specialty tall towers may need to be constructed.

The typical right-of-way width for a 500kV overhead transmission line is 200 feet.

#### Urban/Suburban Construction

Situations where 500kV EHV lines are constructed in urban/suburban areas are rare. Public and agency opinion will almost always require these lines to be routed away from populated areas. In instances where these lines are required to be placed in urban/suburban areas, the predominant structure type is a single steel pole. Urban/suburban construction requirements include the following:

- Traffic control requirements
- Time of work day requirements – in some instances limiting work days to 6-8 hours.
- Environmental Monitoring.
- Public Relations coordination
- Sophisticated crossings designs including overhead netting placed over railroads and/or major highway crossings.
- Coordination with local utilities where crossings or adjustments are required
- Cathodic and fields studies for parallel utility or railroads
- Property and road repair coordination.

Although urban/suburban construction generally has ideal construction access, the rate of production is often much slower due to the numerous coordination efforts and safety concerns associated.

## **4.5 Electrical Considerations**

In addition to the impedance, corona, and losses impacts associated with the line design, electric and magnetic fields studies are generally performed. Please refer to section 3.5.2 for a definition of electric and magnetic fields.

As opposed to an underground cable which only has an associated magnetic field, the term EMF is applicable to an overhead transmission line as it has both electric and magnetic fields associated with it. Considerable research has been performed on the study of EMF's as related to health effects. While conclusive evidence has not been established, at least two states have established standards for EMF. These standards generally establish a maximum field level at the edge of right-of-way.

For an overhead line, the mitigation to reduce these fields is typically the conductor configuration. Specific tower types which place the conductor bundles in a configuration whereby the field effects cancel one another can be used where EMF is a project concern. Generally, this is in urban and suburban settings.

The magnetic field of an overhead line is generally less than equivalent underground line due to the distance of the conductors from the ground.

#### **4.6 Maintenance**

Overhead transmission lines are regularly patrolled for standard maintenance concerns – broken insulators, bird contamination, loose hardware, etc. Because of the tower types and material utilized, these lines generally don't require as much maintenance as lower voltage lines. The typical schedule for line patrols is twice yearly, one aerial and one from the ground.

Standard repair material is typically stocked for emergency events – e.g. tornados, fires – that can destroy large portions of a line. Generally, emergency material is stocked to re-build one to three miles of line.

#### **4.7 Fault Locating**

Location of faults on an overhead line is relatively simple with the sophisticated communications equipment associated with the transmission lines. An overhead outage is generally analyzed by operations personnel and the outage location estimated for patrolmen review. The patrolmen will then drive or fly to the estimated location of the fault to determine the cause. Preparations for repair are generally made within a few hours of an event, depending on accessibility of the line. Depending on the severity of the outage, repair of overhead lines are generally repaired within a few days. In instances of a severe weather related event that damages multiple towers, these outages can last up to 2-3 weeks.

## **5.0 UNDERGROUND CONCEPTUAL DESIGN**

## 5.0 UNDERGROUND CONCEPTUAL DESIGN

The length of the proposed routes exceeds the “critical cable length” of 50 miles for a 500kV XLPE AC cable system, various designs were investigated to determine a feasible conceptual design for this project. As previously mentioned, the longest installed 500kV AC cable system is only 25 miles in length. This project would be the longest 500kV AC cable system installed anywhere in the world. The following factors were considered.

- **Reactive Compensation** – Since the length of both routes exceeds the “critical cable length” for a 500kV cable system, the amount of capacitance and the size of the charging current is the main design consideration for the underground cable system. Various designs were investigated and it was determined that the only way to control the capacitance and the charging current is to install reactive compensation at each end and at intermediate points along the route.
- **Installation Methods** – Spanning a vast project area, installation methodology may further be altered by geological conditions to include rock or sand. In these locations alternate methods of installation may be required which often times have adverse affects to both schedule and budget. Furthermore, steep grades along the route may require supplementary engineering and/or alternate routing; while additional wetland areas often times require a non-evasive installation technique.
- **Right-of-Way** – Route segments encroaching on urban areas will typically encounter the most stringent design and permitting guidelines however right-of-way can often be developed into existing roadway designs. In locations where the duct separation must be reduced, additional ampacity models will need to be developed during final cable design to ensure proper operation of the cable system. Furthermore, an all inclusive geotechnical report for the entire route, returning soil thermal resistivity values, water table depths, and ambient soil temperatures, will need to be performed to ensure cable design. For preliminary development of the east and west alignments, it has been assumed that the minimum right-of-way (ROW) width required is 60 feet, however additional ROW where available should be utilized. To maintain long term flexibility of right-of-way and provide for road design around terrain and obstacles, standard 150-foot right-of-way will be obtained and most or all of it cleared. Because additional ROW is available for the western route, the alignment has been developed on a 150 foot ROW. All ROW must be cleared prior to cable installation and should be maintained to ensure system reliability.
- **Environmental** – It has been assumed the route can be constructed using the open cut, HDD, and J&B conceptual designs. All major wet land areas have been assumed that an HDD will be required for crossing, while major roadways have been designed with J&B crossings. During final route design, the trench details will need to be finalized to account for cable design, splicing/manhole locations, crossing requirements, land user agreements, easement requirements, and any county, state, and federal permitting requirements. Appendix A provides a discussion of the potential environmental impacts from construction, operation, and maintenance of an underground 500kV transmission line.



- Access Roads – During construction, temporary construction roads will be required to install both the duct banks and the manholes. Typically construction roads are developed within the right-of-way or with temporary construction permits and easements, and are designed to handle all foreseen loading requirements of material and construction equipment. After duct bank and manhole installation, the construction roads can be abandoned, or where required refurbished to their original state. Permanent access roads will need to be maintained to each manhole location for future maintenance and cable replacement.

## 5.1 Cable System Design

POWER investigated various trench configurations, number of cables per circuit and cable sizes to determine the appropriate designs for each route. Each cable system was analyzed using the following design criteria:

- |   |   |
|---|---|
| • Ultimate Ampacity Rating                | 4560 Amps                               |
| • Load Factor                             | 75%                                     |
| • Bonding Method                          | Cross-Bonded                            |
| • Conductor Type/Material                 | Segmental/Copper                        |
| • Insulation Type                         | XLPE                                    |
| • Thermal Resistivity (p, rho)            |   |
| ➤ Native Soil                             | 90°C-cm/W                               |
| ➤ Concrete Encasement                     | 60°C-cm/W at 6% moisture                |
| • Ambient Temperature                     |   |
| ➤ Earth                                   | 20°C                                    |
| ➤ Air                                     | 30°C                                    |
| • Maximum Conductor Operating Temperature |   |
| ➤ Steady State                            | 90°C                                    |
| ➤ Emergency                               | 105°C                                   |
| • Depth/Spacing                           | Varies depending on installation method |

### 5.1.1 Open Cut Trench Design

Since the proposed alignments are almost all entirely rural installations, POWER has assumed a maximum trench depth of 5 feet, allowing for approximately 3 feet of cover. While other underground facilities along the route appear to be minimal, it is anticipated that some existing utility crossings will be encountered. Their crossings will need to be determined during final routing design, but in most cases can be crossed either above or below by means of open cut trenching. Where large crossings are required, J&B or HDD installation may be required. Figure 5-1 shows a conceptual design for all open cut trench installations to be placed within a minimum 60 foot right-of-way; predominantly in rural areas. To meet specified power transfer requirements, four cables per phase are required resulting in construction of four independent duct banks; one per set of cables.



**Figure 5-1 Open Cut Trench Design**

### 5.1.2 Trenchless Design

Along each of the proposed routes, a significant number of crossings exist that would require trenchless technology to install the cable system. These crossings include but are not limited to:

Crossing	Segment	Length (ft)	Construction Type
<b>Eastern Route</b>			
Cowlitz River	Segment F	1,100	HDD
Interstate 5/Railroad	Segment F	560	J&B
Coweeman River	Segment F	300	HDD
Kalama River	Segment K	600	HDD
Highway 503	Segment K	200	J&B
Lake Merwin #1	Segment W	1,000	HDD
Lake Merwin #2	Segment W	1,000	HDD
Canyon Creek	Segment O	450	HDD
Lewis River	Segment O	500	HDD
Little Washougal River	Segment 51	1,100	HDD
Camas Slough #1	Segment 52	1,300	HDD
Camas Slough #1	Segment 52	1,300	HDD
<b>Western Route</b>			
Cowlitz River	Segment 4	1,100	HDD
Interstate 5/Railroad	Segment 9	560	J&B
Coweeman River	Segment 9	450	HDD
Kalama River	Segment 9	500	HDD
Lewis River	Segment 25	1,200	HDD
East Fork Lewis River	Segment 25	600	HDD
Salmon Creek	Segment 25	200	HDD
Interstate 205	Segment 25	400	J&B
Camas Slough #1	Segment 52	1,300	HDD
Camas Slough #1	Segment 52	1,300	HDD

**HDD Design**

Figures 5-2 and 5-3 show a conceptual design for a large crossing HDD installation. The design has been developed utilizing typical design criteria as well as assumed environmental restrictions on depth and setbacks. Because of the depth required to install the product casing, the cable installation must be modified to four larger cables per phase to meet the target system ampacity. This larger cable reduces the total cable length that can be placed on a standard shipping reel, thus restricting the maximum HDD length to approximately 1,300 feet. With a minimum casing separation of 20 feet, the right-of-way width must be increased to approximately 100 feet.

It is anticipated that HDD installations will be utilized at all major waterway crossings as well as any crossings in excess of approximately 600 feet, or the maximum distance of a J&B installation. Because some segments have large waterway crossings, in excess of the 1,300-foot limitation of the HDD installation, alternate routing, multiple shorter drills, more cables per phase or other cable delivery methods may be required.

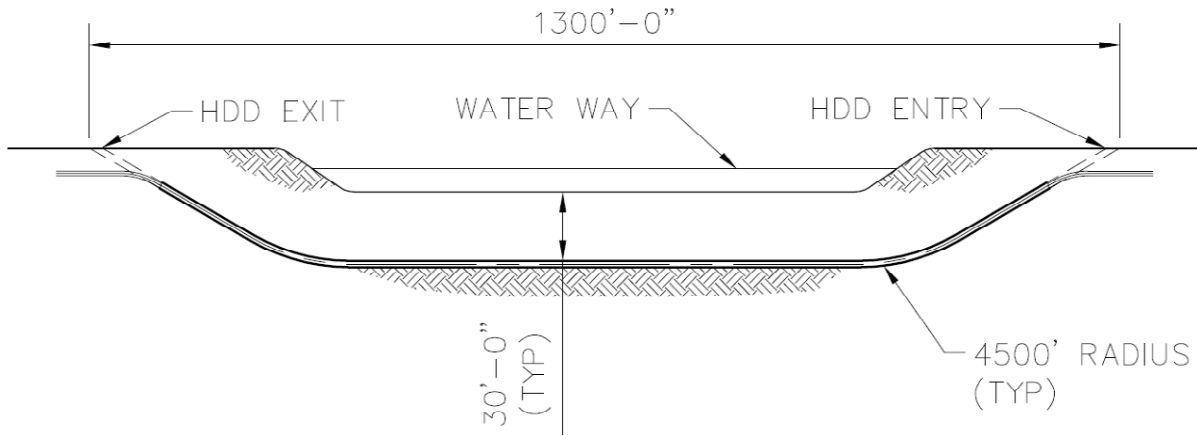

**Figure 5-2: HDD Layout**

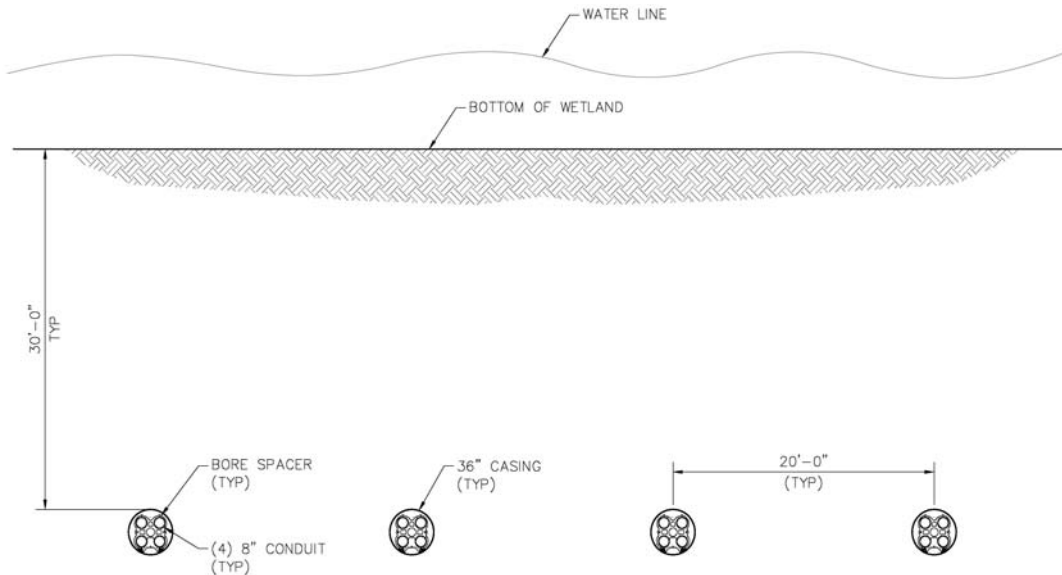

**Figure 5-3: HDD Cross-Section**

**Jack and Bore**

Figures 5-4 and 5-5 show a typical Jack and Bore (J&B) installation. For this Project, it has been assumed that all major roadways within each route will be crossed using the J&B method. Using a J&B will minimize construction impacts to the general public, and when while more expensive than an open cut trench, the installation method general is more accepted by the public and governing agencies.

The typical J&B layout for this Project will utilize a 10 foot wide by 40 foot long jacking pit and a 10 foot by 10 foot receiving pit from which the product casing will be installed. It has been assumed that one J&B will be required for each set of cables, the length of installation will not be greater than 600 feet, and the depth of installation will not adversely affect the cable ampacity. However, the depth of installation is typically governed by existing infrastructure and/or crossing requirements set forth by governing agencies. During final design, cable ampacity should be verified during J&B design to ensure proper operation of the system.

Magnetic field calculations have not been performed for a J&B installation, as the field will be minimized based on the depth of installation. It can therefore be deduced that the field strength will lie between that of an open cut installation and an HDD.

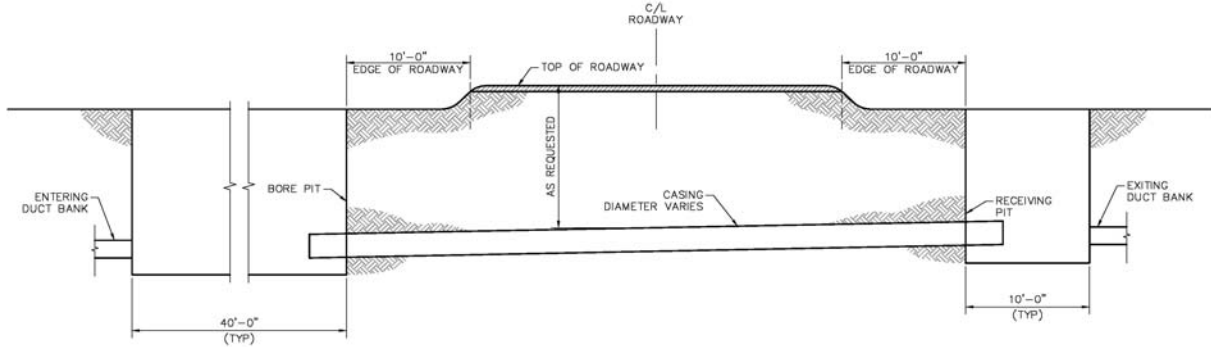

**Figure 5-4: Jack and Bore Layout**

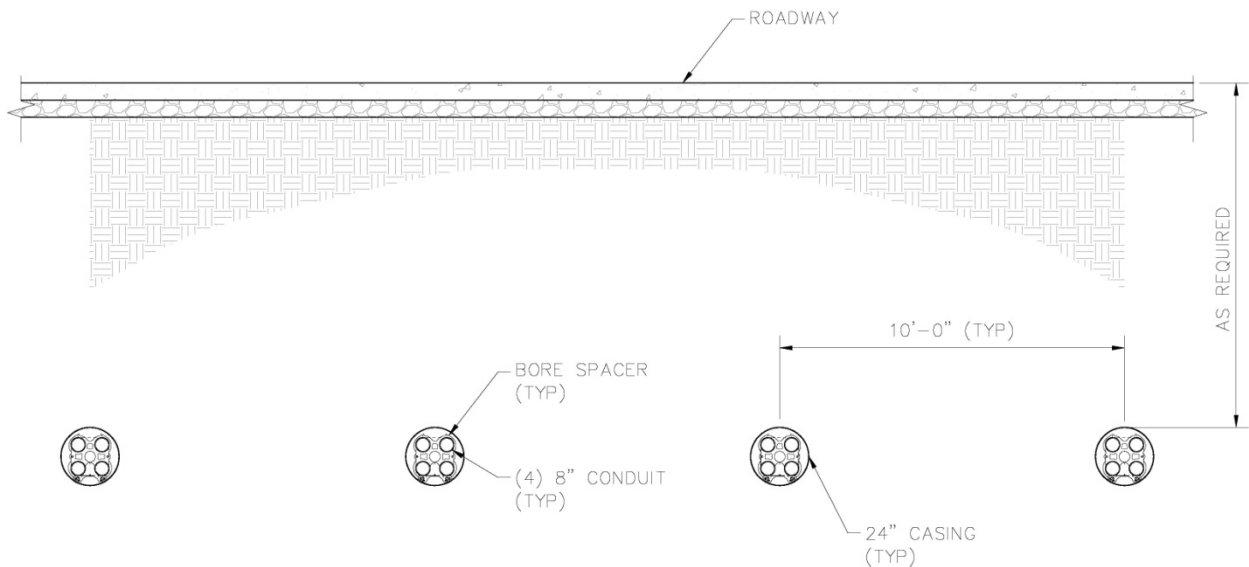

**Figure 5-5: Jack and Bore Cross-Section**

## 5.2 Electrical Characteristics

POWER performed preliminary cable ampacity and electrical characteristics calculations. POWER used CYME International's Cable Ampacity Program (CAP) to model the proposed cable system. Based on the designs developed for the ultimate rating, POWER investigated the number of cables per circuit that would need to be installed today to meet the initial ampacity rating of each design option. Table 5-1 shows the results of the ampacity calculations for each installation method. Table 5-2 shows the electrical characteristics for the cable size and routes.

Because the J&B installation is negligible in length, and has been assumed to have similar operating characteristics to that of an open cut installation, electrical characteristics have not been included.

TABLE 5-1 AMPACITY SUMMARY							
CABLE TYPE	DESIGN	CABLE SIZE (KCMIL)	NO. CABLES/ CIRCUIT	AMPACITY/ CABLE (A)	TOTAL CKT MAX AMPACITY (A)	MINIMUM ROUTE ROW (FT)	MINIMUM TRANSITION SITE ROW (FT)
XLPE	Duct Bank	3500	4	1140	4560	60	400 x 200
	HDD	5000	4	1140	4560	100	400 x 200

TABLE 5-2 ELECTRICAL DESIGN SUMMARY										
CABLE TYPE	DESIGN	CABLE SIZE (KCMIL)	DESIGN LENGTH (MI)	NO. CABLES/ CIRCUIT	SHUNT CAPACITANCE/ CABLE ( $\mu$ F/MI)	TOTAL SHUNT CAPACITANCE ( $\mu$ F/CKT)	REACTIVE CHARGING POWER/ CABLE (MVAR/MI)	REACTIVE CHARGING POWER (MVAR/CKT)	CHARGING CURRENT/ CABLE (A/MI)	TOTAL CHARGING CURRENT/CKT (KA)
EASTERN ROUTE	Duct Bank	3500	74.22	4	0.284	252.94	8.93	7953.4	30.95	27.57
	HDD	5000	1.78	4	0.316	6.75	9.92	211.9	34.36	0.73
WESTERN ROUTE	Duct Bank	3500	67.05	4	0.284	228.51	8.93	7185.1	30.95	24.90
	HDD	5000	1.44	4	0.316	0.932	9.92	171.42	34.36	0.63

Based on the large capacitance and charging current values indicated above, it was determined that intermediate reactor stations would be required. Using a rudimentary electrical model it was determined that a minimum of two intermediate reactor stations and reactors at both substation ends would be required. A minimum of four cables per phase would be needed to achieve the required real power transfer from one end of the route to the other. The preliminary size for these intermediate reactor stations would be approximately 200 foot wide and 700 foot long. Figure 5-6 shows the relationship of the required real ampacity to the available ampacity of a 3500 kcmil 500kV AC cable adjusted for the charging current.

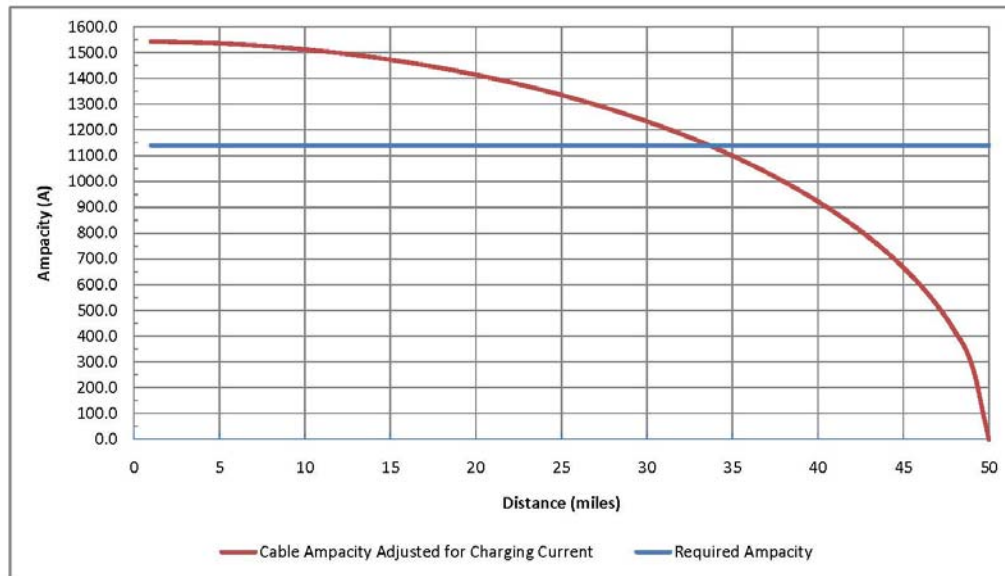

**Figure 5-6: Required Current vs. Cable Rating**

Based on this graph, the longest distance the proposed cable system could be installed without reactive compensation and still achieve the required real power transfer would be about 33 miles. So, in order to achieve the required real power transfer, the conceptual design is based on the circuit being broken up into three equal lengths. While conceptually the proposed design appears to work, it is important to note again that no detailed system analysis has been performed on the BPA existing transmission system. Before considering this design further, a detailed system analysis must be performed to determine the effect of this proposed system on BPA's existing system.

### 5.3 Magnetic Field Calculations

Figures 5-7 and 5-8 show the magnetic field for the open cut trench and HDD designs, respectively. The calculations are based on 100 Amps per cable. It should be noted that the magnetic field is highly dependent upon the actual installation, cable phasing, phase rotation, system operating conditions, and while close, the relationship is not linear.

## 5.4 System Operation

General day-to-day operation of the cable system would consist of all cables in service acting as a current divider to delivery one fourth of the power transfer requirement. In this manner the cable system would function in a standard mode of operation designed to meet the target transfer requirements while remaining within the cable's operating requirement. In the event of a cable failure or during determined outage windows, it is possible to operate the cable system at a reduced capacity with only three, two, or even one, cable per phase. Operating without all cables per phase would reduce the power transfer characteristics but it would allow for the system to remain in operation.

If one set of cables were removed from service, the cables would need to be independently grounded to maintain electrical isolation from the cables remaining in service. This can be done at the transition stations via ground jumpers, three position circuit breakers, or grounding switches.

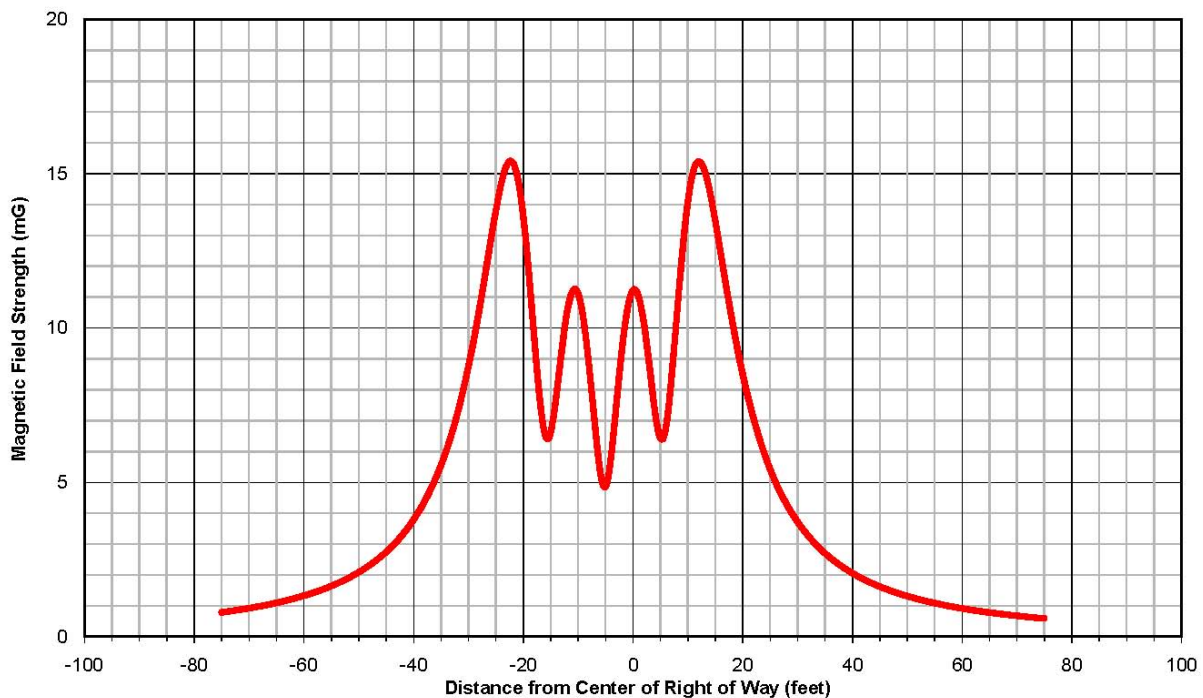
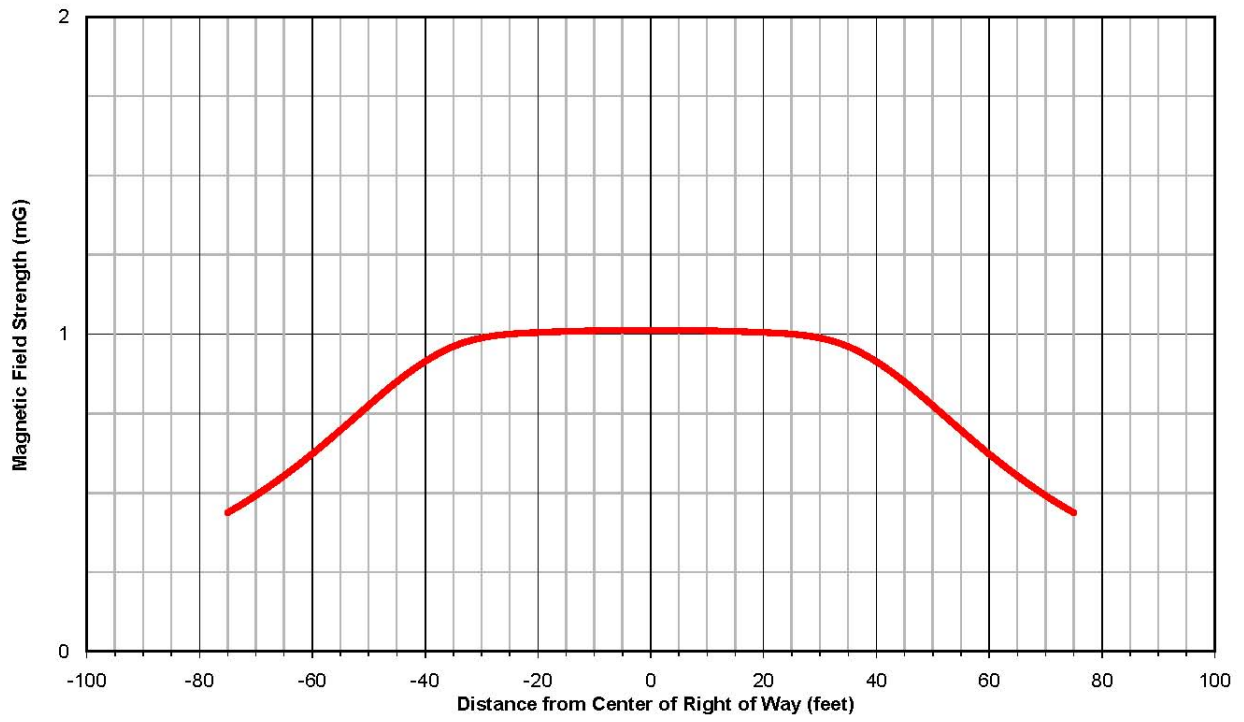

Figure 5-7: Open Cut Trench EMF Calculations



**Figure 5-8: HDD EMF Calculations**



## **6.0 OVERHEAD CONCEPTUAL DESIGN**

## 6.0 OVERHEAD CONCEPTUAL DESIGN

POWER has prepared conceptual designs and preliminary estimates based on the BPA identified routes. The western route will parallel an existing 230kV transmission line within an existing BPA right-of-way. Although the line will have less clearing and access costs due to the use of existing right-of-way, the material and construction costs will be higher as the new line will attempt to match the structure locations of the existing lines it parallels and will require more structures than the Eastern Route, even though the Eastern Route is longer.

### 6.1 Facilities Design

The conceptual design of the transmission line and consequent cost estimates uses the following BPA standard materials:

- Self Supporting Lattice Towers
- Grillage Foundations
- 3-Bundle “Deschutes” Conductor (1519kcmil ACSR/TW, 1.3” diameter, 1.61 lb/ft)
- ½” EHS Overhead Ground Wires

All of these materials are standard BPA materials. For a project of this magnitude, the materials for this line would be ordered specifically for the line. However, once the line is built, the line will have a strong supply of repair material due to the use of these standard materials.

The cost estimates are relatively similar on a cost per mile basis primarily due to the overall mileage. The Western Route is slightly more expensive on a per mile basis due to the aforementioned requirement to parallel an existing lower voltage line. More material and construction locations are required on the Western Route as opposed to the Eastern Route (339 total towers –Eastern Route vs. 364 total towers – Western Route). In addition, the Western Route utilizes some double and even triple circuit towers that the Eastern Route does not utilize. These multi-circuit towers are much heavier and more costly to build than the traditional single circuit towers. Due to these factors, the Western Route has an estimated eight percent (8%) more steel weight than the longer Eastern Route.

The Eastern Route is a so-called “greenfield” line, i.e. new right-of-way and line location. The estimated clearing and access costs for the Eastern Route are approximately 50% higher than the Western Route. This increase in the access costs “balances” the increased material cost of the Western Route, the reason for the relatively similar per mile costs between the two estimates.

### 6.2 Constructability

Both lines assumed traditional construction techniques. The Western Route utilizes an existing road network in place for access. Necessary road building would consist of spur roads from the existing road network to a tower site. Vegetation clearing for the Western Route is less as well due to existing cleared right-of-way for the lines in place. For the Eastern Route, new access and clearing will be required. This will impact schedule and cost of the line.

### **6.3 Special Construction Areas**

Both routes include an overhead crossing of the Columbia River. These crossings will require specialty towers (up to 300 feet tall) to have sufficient clearance over the river. Depending on the placement of these towers, the foundations to support them will be exceptional. If the towers are placed in soft or swampy soils, the foundations may require piling and pile caps. Rocky terrain would likely utilize a grouted foundation.

## **7.0 COST ESTIMATES**

## 7.0 COST ESTIMATES

The cost estimates are based on pricing obtained from manufacturers in summer 2010 and recent underground and overhead projects. There are many factors that affect the overall cost of a transmission line. These factors are:

1. Market Volatility. Recent increases in the cost of copper have resulted in a significant increase in the cable cost for underground lines while similar impacts from aluminum and steel prices will impact the overall cost of an overhead line.
2. Contractor/Manufacturer availability.
3. Subsurface conditions. For underground lines, the type and depth of soil and rock that must be excavated to place the cable can dramatically impact the cost. For example, construction costs in rock formations are significantly higher than construction costs in clay soils. The presence of existing underground facilities also presents a significant uncertainty when estimating the cost of an underground project. For overhead lines, the rock can also impact the cost of the structure foundations.
4. For overhead lines, the accessibility of the line will have a significant impact on the overall project.

### 7.1 Cost Estimate Assumptions

1. Costs represent direct cost to BPA and do not include internal staff costs or interest accrued during construction.
2. Costs are in 2010 dollars. No escalation included.
3. Materials used in the cost estimates meet all applicable industry standards.
4. Cross-bonding of XLPE cable sheaths was assumed.
5. Construction would be performed by qualified craftsmen experienced in installing high voltage underground and overhead transmission systems.
6. BPA to obtain all environmental, local, state, and federal permits as required. The estimates in this document do not include these costs.
7. BPA to obtain all necessary right-of-way and property. The estimates in this document do not include these costs.
8. No spare material has been included.
9. 15% contingency has been added to material and labor costs.
10. Reactive compensation costs have been included at 75% of the required compensation.
11. Rock excavation costs were estimated based on geological study provided by BPA for each route. Rock is assumed to be drilled and blasted.

12. Large waterways and wetlands have been assumed to be crossed by HDD.
13. Major roadways have been assumed to be crossed by J&B.
14. Access roads for the underground have been assumed to be similar in design and length to that of an overhead option.
15. The clearing required for the underground and the overhead has been assumed to be 60-foot wide and 150-foot, respectively, for 80% of the eastern route length. The clearing required for the western route has been assumed to be 150-foot wide for both lines for 50% of the route length.
16. Construction management and design engineering has been included.
17. All materials have an 8% sales tax included

## 7.2 Underground Cost Estimates

TABLE 7-1 UNDERGROUND COST ESTIMATES		
	Eastern Route	Western Route
Length, miles	76	68.5
Design Engineering	\$9,041,000	\$8,118,000
Construction Management	\$56,372,000	\$49,457,000
Material	\$1,505,930,000	\$1,328,440,000
Construction	\$485,195,000	\$394,444,000
Testing and Energization	\$4,083,000	\$3,441,000
Subtotal Cost	\$2,060,621,000	\$1,783,900,000
Contingency	\$309,100,000	\$267,590,000
Total Cost	\$2,369,721,000	\$2,051,490,000

### 7.3 Overhead Cost Estimates

TABLE 7-2 OVERHEAD COST ESTIMATES		
	Eastern Route	Western Route
Length, miles	76	68.5
Design Engineering	\$3,630,000	\$3,530,000
Construction Management	\$8,468,000	\$8,237,000
Material	\$38,622,000	\$38,349,000
Construction	\$82,349,000	\$79,314,000
Testing and Energization	\$0	\$0
Subtotal Cost	\$133,069,000	\$129,430,000
Contingency	\$18,146,000	\$17,650,000
Total Cost	\$151,215,000	\$147,080,000

### 7.4 Cost Estimates Comparison

TABLE 7-3 COMPARISON COST ESTIMATES			
Route/Installation	Length (mi)	Overhead Cost	Underground Cost
Eastern Route	76	\$151,215,000	\$2,369,721,000
Western Route	68.5	\$147,080,000	\$2,051,490,000

## **Appendix A – Environmental Report**



January 21, 2011

## BONNEVILLE POWER ADMINISTRATION

---

### **Environmental Impacts Associated with Overhead and Underground 500-kV Transmission Line Construction, Operation and Maintenance Activities**

*PROJECT NUMBER:*  
119864

*PROJECT CONTACT:*  
Brian Furumasu  
*EMAIL:*  
Brian.Furumasu@powereng.com  
*PHONE:*  
(503) 293-7124



*Environmental Impacts Associated with  
Overhead and Underground 500-kV  
Transmission Line Construction,  
Operation and Maintenance Activities*

*PREPARED FOR: BONNEVILLE POWER ADMINISTRATION*

*PREPARED BY: BRIAN FURUMASU*

*(503) 293-7124*

*BRIAN.FURUMASU@POWERENG.COM*

*WENDY HOSMAN*

*(208) 788-0409*

*WENDY.HOSMAN@POWERENG.COM*

REVISION HISTORY		
DATE	REVISED BY	REVISION
01/21/2011	Wendy Hosman	0

## TABLE OF CONTENTS

<b>1.0</b>	<b>INTRODUCTION .....</b>	<b>1</b>
<b>2.0</b>	<b>DESCRIPTION OF RESOURCES IMPACTED BY OVERHEAD AND UNDERGROUND 500-KV TRANSMISSION LINE CONSTRUCTION, OPERATION AND MAINTENANCE ACTIVITIES.....</b>	<b>1</b>
2.1	LAND USE .....	1
2.1.1	Classifications of Land Use.....	1
2.2	BIOLOGICAL RESOURCES .....	2
2.3	GEOLOGICAL AND SOIL RESOURCES .....	2
2.4	WATER RESOURCES.....	2
2.5	CULTURAL RESOURCES.....	3
2.6	VISUAL RESOURCES .....	3
<b>3.0</b>	<b>ENVIRONMENTAL IMPACTS ASSOCIATED WITH OVERHEAD AND UNDERGROUND 500-KV TRANSMISSION LINE CONSTRUCTION, OPERATION, AND MAINTENANCE .....</b>	<b>4</b>
3.1	OVERHEAD TRANSMISSION LINES.....	4
3.2	UNDERGROUND TRANSMISSION LINES .....	5
3.2.1	Frac-out Event .....	6
3.2.2	Increased Soil Temperature .....	6
3.2.3	Fluid Leaks .....	7
3.3	LAND USE .....	7
3.3.1	Agriculture – Overhead Line Impacts .....	7
3.3.2	Agriculture – Underground Line Impacts .....	8
3.3.3	Forests – Overhead Line Impacts .....	8
3.3.4	Forests – Underground Line Impacts .....	9
3.3.5	Parks, Recreation, and Preservation – Overhead Line Impacts.....	9
3.3.6	Parks, Recreation, and Preservation – Underground Line Impacts .....	10
3.3.7	Residential – Overhead Line Impacts.....	11
3.3.8	Residential – Underground Line Impacts.....	11
3.3.9	Commercial – Overhead Line Impacts .....	11
3.3.10	Commercial – Underground Line Impacts .....	12
3.3.11	Public Facilities – Overhead Line Impacts.....	12
3.3.12	Public Facilities – Underground Line Impacts .....	12
3.3.13	Industrial – Overhead Line Impacts .....	12
3.3.14	Industrial – Underground Line Impacts.....	13
3.3.15	Transportation and Access – Overhead Line Impacts .....	13
3.3.16	Transportation and Access – Underground Line Impacts .....	14
3.3.17	Land Use Mitigation Techniques .....	14
3.4	BIOLOGICAL RESOURCES .....	16
3.4.1	Vegetation Resources .....	16
3.4.2	Wildlife Resources .....	22
3.4.3	Biological Resources Mitigation Techniques.....	27
3.5	GEOLOGICAL AND SOIL RESOURCES .....	33
3.5.1	Soil Erosion and/or Compaction – Overhead Lines .....	33
3.5.2	Soil Erosion and/or Compaction – Underground Lines .....	34

3.5.3	Reclamation Constraints Due to Soil Type – Overhead and Underground Lines .....	34
3.5.4	Disturbance or Access Limitations to Mineral Resources – Overhead and Underground Lines.....	34
3.5.5	Disturbance to Unique Geological Features – Overhead Lines.....	35
3.5.6	Disturbance to Unique Geological Features – Underground Lines.....	35
3.5.7	Disruption of Soil Profile – Overhead Lines .....	35
3.5.8	Disruption of Soil Profile – Underground Lines .....	36
3.5.9	Geological and Soil Resources Mitigation Techniques.....	36
3.6	WATER RESOURCES.....	37
3.6.1	Disturbance to Surface Water Flows and Floodplains – Overhead Lines .....	38
3.6.2	Disturbance to Surface Water Flows and Floodplains – Underground Lines .....	38
3.6.3	Disturbance to Wetlands – Overhead Lines .....	38
3.6.4	Disturbance to Wetlands – Underground Lines.....	39
3.6.5	Disturbance to Groundwater – Overhead Lines .....	39
3.6.6	Disturbance to Groundwater – Underground Lines.....	40
3.6.7	Water Quality Degradation – Overhead Lines .....	40
3.6.8	Water Quality Degradation – Underground Lines.....	41
3.6.9	Water Resources Mitigation Techniques.....	41
3.7	CULTURAL RESOURCES .....	43
3.7.1	Ground Disturbance – Overhead and Underground Lines .....	43
3.7.2	Visual and Audible Intrusions – Overhead Lines.....	43
3.7.3	Visual and Audible Intrusions – Underground Lines .....	44
3.7.4	Vandalism – Overhead and Underground Lines .....	44
3.7.5	Increased Visitation – Overhead and Underground Lines.....	44
3.7.6	Cultural Resources Mitigation Techniques .....	44
3.8	VISUAL RESOURCES .....	46
3.8.1	Visual Resource – Overhead Lines .....	46
3.8.2	Visual Resources – Underground Lines .....	49
3.8.3	Visual Resources Mitigation Techniques .....	50
3.9	PUBLIC HEALTH AND SAFETY .....	52
3.9.1	Electric and Magnetic Fields (EMF) – Overhead and Underground Lines .....	52
3.10	VEGETATION MANAGEMENT MITIGATION TECHNIQUES .....	53
3.10.1	Manual and Mechanical .....	53
3.10.2	Chemical.....	53
<b>4.0</b>	<b>SUMMARY .....</b>	<b>55</b>
4.1	RELATIVE ENVIRONMENTAL IMPACT SEVERITY OF OVERHEAD VERSUS UNDERGROUND 500-kV TRANSMISSION LINES.....	56
<b>5.0</b>	<b>REFERENCES .....</b>	<b>59</b>

## LIST OF TABLES

TABLE 1	LANDFORM CONTRAST MATRIX.....	47
TABLE 2	CONSTRUCTION OF 500-kV TRANSMISSION LINES.....	57
TABLE 3	MAINTENANCE AND OPERATIONS OF 500-kV TRANSMISSION LINES .....	58

## 1.0 INTRODUCTION

This report provides a discussion of the potential environmental impacts from construction, operation, and maintenance of an overhead and underground 500 kilovolt (kV) transmission line. A description of the types of environmental resources which may be impacted by a new overhead and underground 500-kV transmission line is provided, followed by a discussion of potential environmental impacts which may occur to these resources. The environmental impacts presented are general impacts and they do not relate to a specific project, location, or project proponent. Therefore, the environmental impacts and associated mitigation measures in this report may or may not apply to any particular project. This Environmental Report is meant to serve as a general guide for 500-kV transmission line project proponents to assist in assessing the potential environmental impacts for their own specific projects.

## 2.0 DESCRIPTION OF RESOURCES IMPACTED BY OVERHEAD AND UNDERGROUND 500-KV TRANSMISSION LINE CONSTRUCTION, OPERATION AND MAINTENANCE ACTIVITIES

This assessment of various environmental outcomes focuses on those resources most likely to be affected during the construction, operation, and maintenance of a new 500-kV transmission line project. For purposes of this assessment, a generic or programmatic approach is used to describe construction techniques, affected environment, and environmental impacts.

Resources typically affected by overhead and underground 500-kV transmission line construction, operation, and maintenance activities include the following:

- Land Use
- Biological Resources
- Geological Resources and Soils
- Water Resources
- Cultural Resources
- Visual Resources

### 2.1 Land Use

Most transmission line construction projects cross many miles of countryside, traversing numerous land uses and property ownerships. Certain types of land uses are more compatible with transmission line construction and operation than others. Some land uses are more prone to short-term or temporary disruption occurring during the construction phase, and these uses can be promptly resumed after the transmission facilities are installed (DOE and DOI 2007).

#### 2.1.1 *Classifications of Land Use*

There are many land uses that can be affected by construction, operation, and maintenance of 500-kV transmission lines. The major land use categories are as follows:

- **Agriculture:** lands used for agriculture production (e.g., farm fields, row crops, irrigated lands, orchards, nurseries, pastures, rangelands, etc.).
- **Forests:** lands primarily occupied by trees (includes commercial, private, and public forests).

- 
- **Parks, recreation and preservation areas (also sometimes called conservation areas):** land areas where the established or proposed land use is primarily for recreational enjoyment, or to protect and preserve a valuable environmental resource. Examples include significant ecological areas, wilderness areas, areas of critical environmental concern, environmentally sensitive habitats, wildlife refuges, preserves, rivers, floodplains, vacant urban lands, general rural lands, golf courses, national parks, local or regional parks, campgrounds, fairgrounds, and playgrounds.
  - **Residential:** single family residences, multi-family residences such as condominiums or apartments, townhouses, and mobile home parks.
  - **Commercial:** retail stores, shopping centers, professional offices, business parks, retail plant nursery, and hotels/ motels.
  - **Public Facilities:** educational institutions, religious facilities, health care buildings, government offices, police and sheriff stations, fire stations, public parking facilities, correctional facilities, day care centers, cemeteries, hospitals, and nursing homes.
  - **Industrial:** lands used for mineral extraction such as open pit mines (including mining claims), oil wells, oil refineries, tank farms, substations, gravel pits, concrete plants, solid and hazardous waste landfills, and manufacturing.
  - **Transportation and access:** the existing network of access to lands in the area. This includes interstate highways, parkways and roads, airports, railroads, park and ride lots, bus, truck, and railroad terminals.

## 2.2 Biological Resources

Biological resources refer to all the species living together in an area. Biological resources can be divided into two broad categories: vegetation and wildlife. Biological resources can be affected by construction, operation, and maintenance of an overhead or underground 500 kV transmission line.

*Vegetation* is a general term for the plant life of a region. It refers to ground cover life forms, structure, spatial extent or any other specific botanical or geographic characteristics, including cultivated, ornamental, domestic, and native plants.

*Wildlife* includes all living creatures that are a part of the natural ecosystem that are not tamed or domesticated. Wildlife includes, but is not limited to, birds, reptiles, fish, amphibians, and mammals.

## 2.3 Geological and Soil Resources

Geological resources are based on geology -- the materials the earth is made of, the processes that act on those materials, the products formed, and the history of the planet and its life forms since its origin. Soils are a type of geological resource. Soils are described as a naturally occurring, unconsolidated, or loose covering of broken rock particles and decaying organic matter (humus) on the surface of the earth, capable of supporting life.

## 2.4 Water Resources

Water resources is a general term for the availability (the location, spatial distribution, or natural fluctuations of water), accessibility (given availability, whether people can access it), and quality

---

(whether accessed water is free of contaminants and safe for consumption) of water. There are four categories of water resources that can be affected by construction, operation, and maintenance of overhead and underground 500-kV transmission lines:

- Surface water
- Wetlands
- Floodplains
- Groundwater

## 2.5 Cultural Resources

Historic property as defined by (36CFR800.16(1)(1)) means any prehistoric or historic district, site, building, structure, or object included in, or eligible for inclusion in, the National Register of Historic Places maintained by the Secretary of the Interior. This term includes artifacts, records, and remains that are related to and located within such properties. The term also includes properties of traditional religious and cultural importance to an Indian tribe or Native Hawaiian organization and that meet the National Register criteria.

For the purposes of this report, three categories of cultural resources are considered, which can be affected by construction, operation, and maintenance of overhead and underground 500-kV transmission lines. These include:

- Prehistoric and historic archaeological resources
- Architectural resources
- Traditional cultural properties

*Prehistoric and historic archaeological resources* are locations where human activity has measurably altered the earth or left deposits of physical remains (e.g., stone projectile points, bottles). Federal acts and regulations (e.g., NHPA, 36 CFR part 800) use the term “prehistoric” to refer to archaeological resources associated with Native Americans prior to contact with Euro-Americans. This term is also commonly understood to mean cultural resources that pre-date the use of written records for an area. Historic archaeological resources are generally those that post-date Euro-American contact with Native Americans.

*Architectural resources* are standing buildings or structures and may include houses or cabins, barns, dams, lined canals, and bridges.

*Traditional Cultural Properties* (TCPs) can be defined generally as one that is eligible for inclusion in the National Register because of its association with cultural practices or beliefs of a living community that (a) are rooted in that community's history, and (b) are important in maintaining the continuing cultural identity of the community (Parker and King, 1998).

## 2.6 Visual Resources

Visual resources refer to the natural and man-made features in the project area and include cultural and historic landmarks, landforms of particular beauty or significance, water surfaces, and vegetation. Together these features form the overall impression that a viewer receives of an area or its landscape character.

---

### **3.0 ENVIRONMENTAL IMPACTS ASSOCIATED WITH OVERHEAD AND UNDERGROUND 500-KV TRANSMISSION LINE CONSTRUCTION, OPERATION, AND MAINTENANCE**

This section provides an assessment of potential environmental impacts of overhead and underground 500-kV transmission lines and associated structures, access roads, construction activities, and materials, and operation and maintenance of the line on land use, biological, geological, water, cultural, and visual resources. Environmental impacts are defined as modifications to the existing condition of the environment that can be brought about by the implementation of a project.

Various impacts can result from project activities directly or indirectly. These impacts can either be beneficial, adverse, or neutral and can last for the long term or short term. Long-term impacts are sometimes permanent, but are categorized as long lasting. Long-term impacts are those that remain substantial throughout the life of the project or beyond. Short-term impacts are temporary and are those that result in changes to the environment during construction, but revert to a pre-construction condition at or within a few years of the end of construction. Impacts can vary in intensity from no change, to a slightly discernible change, to a full modification of the environment.

Construction impacts from overhead and underground 500-kV transmission lines are a result of installation of the infrastructure including substations, development of new access roads and right-of-way (ROW) clearing. Operation and maintenance impacts from overhead and underground 500-kV transmission lines are a result of required regular inspections and maintenance to identify problems caused by weather, vandalism, and vegetation. Inspection and maintenance activities can potentially interfere with regular land use activities and environmental resources.

Road maintenance is necessary to maintain access to transmission facilities; to prevent damage to the road; maintain safety by reducing dust, washboards, and graveling; and to preclude adverse impacts to resources resulting from lack of road maintenance. The potential adverse impacts of road maintenance are considered in the context of performing maintenance versus possible consequences of not maintaining roads.

Vegetation management is typically a major maintenance activity on overhead and underground transmission line corridors. Vegetation on ROW and access roads is controlled and managed by a variety of methods, including trimming, mowing, and use of herbicides. In general, utilities strive to remove intrusive vegetation or direct tall-growing vegetation away from transmission facilities and the ROW.

#### **3.1 Overhead Transmission Lines**

Construction of overhead 500-kV lines involves ground disturbance for the foundation(s) of each of the structures for structure support, and also requires heavy lifting equipment during construction with either conventional cranes or a heavy duty helicopter to set the tower structures and pull the transmission conductors.

Typically a drill rig with power auger would be used to excavate pole and tower foundations. Excavation activities would require access by the necessary equipment including a power auger or drill, crane, material trucks, and ready-mix trucks. After excavation is complete, steel reinforced cages would be placed into the excavated holes. Anchor bolts would be installed in the foundation template form. Concrete would be poured to the required height for the foundations. Poles or tower structures would be placed on foundation anchor bolts as soon as the foundations are ready.



---

Steel pole or tower sections and associated hardware would be transported to work areas by truck. Structures would be assembled within the work area and hoisted in place by a large crane or helicopter.

Once the structures are in place, a pilot line would be pulled (strung) from structure to structure via helicopter. The line would be threaded through the stringing sheaves on each pole. A larger diameter, stronger line would then be attached to the pilot line and strung through the sheaves. The former line is referred to as the sock line and the latter as the pulling line. Finally, the conductor would be attached to the pulling line and strung through the sheaves. This process would then be repeated until the conductor is pulled through all the sheaves. Conductor splicing would be required at the end of a conductor reel or if a conductor is damaged during stringing.

Initial ROW clearing would be conducted to the extent necessary to provide safe and reliable operation of electric lines and to maintain the health of the vegetation in the ROW. Numerous studies conclude that the use of stable, low-growing, less intrusive plant communities can be one of the most effective vegetation management tools on overhead transmission ROW (Bramble and Byrnes, 1983; Nesmith et al., 2008). Documented benefits of this vegetation management approach include improved cost effectiveness, service reliability, safety, aesthetic appeal, as well as decreased fire risk, and wildlife habitat enhancement. However, there can also be detrimental environmental impacts associated with vegetation management activities.

Typically existing roads would be used wherever feasible to access the line for construction, but temporary roads are often required to access all portions of the line. Temporary access would run the entire length of the line within the ROW with permanent access to transmission line structures and substations.

Environmental impacts from overhead transmission lines can be a direct result of the type of structure, structure heights, structures spans, and ROW width. These construction components will vary depending on the particular project and terrain that must be crossed. Typical structure heights range from 150 to 200 feet. Structure heights are typically kept at 200 feet or less because structures over 200 feet would need to comply with FAA requirements of having blinking red aircraft warning lights installed and the structures may be required to be painted in bands of orange and white. Major river crossings will typically have taller structures on each side of the river to allow a complete span of the river. Typical structure spans are between 1,000 to 1,400 feet and a typical ROW width is approximately 200 feet.

### **3.2 Underground Transmission Lines**

The construction of underground 500-kV transmission lines requires a large amount of ground disturbance since open cut trenching is the most common method of installation. In this method, a backhoe or excavator is used to dig a trench of the required width and depth in accordance with the design for the installation. Trenches for 500-kV transmission lines are approximately three to four feet wide and six to ten feet deep in typical terrain. Reclaimed soil is used as backfill and to even out existing grades. If groundwater or storm water inflow is encountered during trenching, dewatering and disposal of the water is required. To prevent cave-ins, sheeting and shoring of the trench side walls using plywood or other materials is required whenever the trench bottom is deeper than five feet. Sheeting and shoring may be avoided where it is possible to step back the trench. Additional ground disturbance may result if step back trenching is used.

Conduits are used to allow for ease of pulling the 500-kV cables and are placed in the trench in an arrangement to minimize thermal effects and provide a location for the splicing of the cables for continuity of the line (500 kV will require four, eight-inch diameter conduits, where one conduit will be used as a spare in the event of a cable failure for ease of pulling a replacement cable). Buried manholes

---

are required if the actual distance of the underground segment exceeds the length of a reel of cable; typical cable reel lengths are 1,500 to 1,700 feet depending on the actual cable type and limitation on delivery of the cable reels (as large as 14 feet in diameter and weight of 55,000 to 75,000 pounds, depending upon the cable length and the conductor size). Typical 500-kV manholes are 30 feet in length, 10 feet wide and eight feet high to allow for the splicing and “racking” of the cables. Access to the cables is limited only to the manholes.

Transition stations are required to terminate the underground cables and to connect to the overhead transmission line. Transition stations are typically four to five acres each, depending upon switching schemes or system composition requirements, and located on both ends of the underground circuit. The stations are completely fenced and would be secured for safety reasons, similar to conventional electrical substations.

Trenchless installation methods require the installation of an entry and exit pit approximately 20 feet by 40 feet with a depth sufficient for the casing product. The entry and exit pit for directional drilling would be much smaller than other trenchless methods. The number of pits required on a given project depends on the length of the project. There would also be temporary disturbance around the entry and exit pits from equipment and workers.

Underground ROW widths can be limited to the area containing the line and an area on each side of the line to protect the line from unintentional excavation damage and for access. Depending on the construction techniques and project requirements, this width can vary from 40 to 100 feet. An unimpeded path suitable for heavy excavation equipment is required along the entire cable ROW to provide access for maintenance and repair crews. For underground installation in streets, the space requirements are usually limited to about the size of the duct bank, since the transmission line must share the space available in the street with other utilities.

### **3.2.1 *Frac-out Event***

A frac-out event occurs when excessive drilling pressure is applied and drilling mud propagates vertically toward the surface through fractured bedrock or overlying soils. This event has the potential to cause damage to environmental resources at the site of the frac-out and beyond. The damage can vary depending on the severity and location. Impacts would result from subsurface soils being spread over the land surface. Small frac-out events in urban settings or highly disturbed areas may be considered as a low, short term impact. A large frac-out event (temporary or long term) may be considered to have high impacts in areas of intense agricultural production; where there are rare, threatened and endangered species; in or near rivers, streams, wetlands or other water resources; on or near steep slopes or erosive soils; if there are cultural resources in the area; or if near a visually sensitive area.

### **3.2.2 *Increased Soil Temperature***

Heat produced by the operation of an underground line raises the temperature a few degrees at the surface of the earth above the line. This is not enough to harm growing plants, but it can cause premature seed germination in the spring. Heat could also build up in enclosed buildings near the site. According to an EPRI report titled Study of Environmental Impact of Underground Electric Transmission Systems, this local increase in soil temperature becomes negligible (even at maximum load conditions) at distances of 15 to 20 feet from the trench center line (EPRI, 1975).

---

### **3.2.3 Fluid Leaks**

Both high pressure fluid filled and self contained fluid filled cables most commonly utilize an insulating fluid that can be released to the environment from underground cables through leaks in pipe joints, from corrosion, or by accidental damage to the cable system. The two most common types of dielectric fluid are alkylbenzene (which is used in making detergents) and polybutene (which is chemically related to styrofoam).

A fluid leak can migrate downward through the soil or may preferentially follow a migration path along the pipe backfill material and along intersecting utilities. Depending on the volume of fluid released, the soil properties, and the depth to groundwater, the fluid may reach the groundwater and accumulate as a lens or plume floating on the water table, potentially impacting nearby wells. Fluid-reaching storm sewers or other conduits may discharge to waterways and degrade surface water quality. In addition, the release and degradation of alkyl benzene could cause benzene compounds to show up in plants or wildlife (benzene is a known carcinogen). Alkyl benzene is also slow to degrade in the environment.

Any soil contaminated with leaking dielectric oil is classified as a hazardous waste. This means that any contaminated soil or water must be remediated. Contaminated areas (soil and water) must be delineated, characterized, and cleaned up. Costs associated with these activities can rapidly escalate because of the diffusive nature of the dielectric fluids, especially in water. Older cable systems can be more prone to leaks and seeps and thus may present higher risk.

### **3.3 Land Use**

Siting a line through highly sensitive land uses (e.g., historic sites and structures), intensive land uses, including residential and commercial developments, and public facilities in thickly settled areas, can be a challenge when constructing, operating and maintaining overhead and underground 500-kV transmission lines. Other land uses, such as some forms of agriculture, including rangeland and pasture, are somewhat more amenable to the presence of a 500-kV transmission line with little to no long-term impact to livestock grazing within the ROW.

All land uses in the area at or near the overhead or underground 500-kV transmission line can be temporarily disrupted by construction, operation, and maintenance activities such as noise, dust, and construction traffic. Heavy construction equipment or maintenance equipment on temporary and permanent access roads could also cause a temporary disturbance to adjacent land uses, including temporary loss of access. Existing utility lines (e.g., telephone, cable, gas, etc.) may require relocation or can be damaged as a result of construction of the overhead transmission line possibly leading to disruption of service. Mechanical vegetation management can leave piles of vegetation debris on or nearby the ROW, which can create obstacles or hazards for various land users.

#### **3.3.1 Agriculture – Overhead Line Impacts**

While most agriculture activities can take place under 500-kV transmission lines, if the towers are placed in active farm fields, then the area around the tower base will be taken out of production. The presence of new project components and ROW can also permanently disrupt active farming operations by dividing or fragmenting agricultural fields, obstructing access, impeding the delivery and use of water for livestock and irrigation, reducing the efficiency of windbreaks, impeding aerial spraying, and/or disrupting the operation of farm equipment.

Two types of land classified under the agricultural land use heading, pasture and rangeland, are quite adaptable to overhead electric transmission facilities in that once construction is completed, there would

---

be little to no long-term impacts (a few hundred square feet per structure site). Also, orchards (depending on the height of the trees in respect to the overhead conductors), vineyards, and Christmas tree plantations and nurseries might be compatible within most of the ROW environment.

The Conservation Reserve Program (CRP) is a cost-share and rental payment program under the United States Department of Agriculture, and is administered by the Farm Service Agency. CRP is a voluntary program for agricultural landowners whereby they can receive annual rental payments and cost-share assistance to establish long-term, resource conserving covers on eligible farmland. CRP lands that are crossed by an overhead transmission line require a Farm Service Agency assessment of the adverse effects on the participant's CRP acreage. If the Farm Service Agency determines that the use will have adverse effects on CRP acreage, the affected acreage may be terminated and refunds assessed.

Agricultural land, when located on or near a transmission ROW, can be significantly impacted if adequate care is not taken when managing ROW vegetation. Agriculturally significant plants or crops should not be harmed when controlling undesirable vegetation on the ROW.

### **3.3.2 Agriculture – Underground Line Impacts**

Impacts to agricultural land uses from construction, operation, and maintenance of an underground 500-kV transmission line would be similar to impacts from an overhead 500-kV transmission line with the following exceptions.

Long term negative impacts to agricultural lands would result from the construction of underground transmission lines. In order to operate and perform maintenance on the line, the ROW for the underground lines must be kept clear at all times. Some farming activities cannot be performed over the top of underground transmission lines as tillage equipment can contact and damage the underground installation and disrupt the thermal backfill that is used to dissipate heat from the installation. Orchards, vineyards, Christmas tree plantations, and nurseries would not be compatible with an underground transmission line because the roots may interfere with the underground system and their presence would not be acceptable for maintenance of the ROW either.

Grasses are used to stabilize the surface of the underground installation. In some cases, grazing is a compatible use on the ROW if the project is located in pastures or range land.

A frac-out event, as well as fluid leaks, may disrupt agricultural activities and may potentially destroy agricultural products and long term production of the soil through the displacement of subsurface soils onto the land surface and result in soil contamination. Any required clean-up activities may also disrupt agriculture activities and production. Increased soil temperatures may cause premature seed germination in the spring which may affect agriculture production.

Trenchless installation methods, such as directional drilling, would be able to preserve the above-ground agriculture resources. Temporary disturbance may occur around the entry and exit pit(s) from equipment and workers. Permanent disturbance would occur at the entry and exit pit areas as vegetation removal would be required for permanent access to this area.

### **3.3.3 Forests – Overhead Line Impacts**

Installation of an overhead transmission line may not be compatible with applicable forest management plans or designated forest conservation uses. When clearing a new ROW in heavily forested areas without substantial topographic relief (no deep ravines, gorges, and valleys), all tall-growing tree species usually must be removed from the entire ROW, and prevented from growing in the future for the secure

---

and safe operation of the transmission line. Some tall trees along the outside edges of the ROW may need to be removed individually as they may be deemed dangerous due to their age and potential of falling, etc.

However, complete and total clear cutting (i.e., removal of all woody biomass), need only occur on those portions of the ROW devoted to access roads and support structure sites. In other ROW locations, vegetation, many shrubs, and some low stature trees may be kept intact to act as residual cover. In road-side screens and stream-side buffer zones, some of the taller-growing species can be kept in place if they are currently well below the conductors. Taller-growing tree species can then be removed over time as other more desirable vegetation begins to grow and develop, thereby keeping the screens and buffers sufficiently vegetated at all times. All merchantable timber felled within the ROW and from along its outside edges can be piled in such a way that enables the underlying fee owner to retrieve this resource or otherwise make these logs available for salvage operations in an environmentally acceptable manner (Miller, 2007). If the land is used for logging operations, the transmission line ROW would be lost for productive logging activities, but logging operations could continue outside the ROW.

In some instances, particularly in mountainous terrain, support structures can be placed on high points and the height of the structures increased to span longer distances with greater ground clearance. In these situations, trees which may grow taller can often be retained in ROW locations that have sufficient line to ground distances and many forestry related activities can proceed unaltered. In other situations, with only slightly increased conductor heights, some lower stature trees can still be maintained within the ROW, along with trees that have a slow growth rate (i.e., their annual height increment is marginal); although, in most instances all trees are removed within the ROW.

### **3.3.4 Forests – Underground Line Impacts**

Long term negative impacts occur to timber producing forestlands from the construction of underground transmission lines using trenching methods. In order to operate and perform maintenance on the line, the ROW for the underground lines must be kept clear of trees, including deep ravine, gorge, and valley crossings, therefore unavailable for timber production or management.

Trenchless installation methods, such as directional drilling, would be able to preserve the above-ground forestry resources. Temporary disturbance may occur around the entry and exit pit(s) from equipment and workers. Permanent disturbance would occur at the entry and exit pit areas as tree removal would be required for permanent access to this area.

A frac-out event, as well as fluid leaks, may disrupt and/or destroy adjacent forests and forestry activities and may potentially destroy forest products and long term production of the soil through the displacement of subsurface soils onto the land surface and result in soil contamination. Any required clean-up activities may also disrupt forest resources and activities.

Trenchless installation methods, such as directional drilling, would be able to preserve the above-ground forest resources. Temporary disturbance may occur around the entry and exit pit(s) from equipment and workers. Permanent disturbance would occur at the entry and exit pit areas as vegetation removal would be required for permanent access to this area.

### **3.3.5 Parks, Recreation, and Preservation – Overhead Line Impacts**

Outdoor recreation activities such as hiking, camping, birding, and hunting are most affected by transmission construction activities, but impacts can also be longer term in some places depending on the level of vehicle use associated with the operations and maintenance of the transmission project. Short- and long-term impacts associated with the degradation in the quality of the visual landscape would also

---

likely occur in some areas. Some areas may become more accessible, with increased opportunities for recreational activities in previously inaccessible (or less accessible) areas, while other areas may become less accessible (DOE and DOI, 2007).

Many parks, intensive recreation sites, special conservation areas, all federally designated wilderness areas<sup>1</sup>, as well as properties on the National Register of Historic Places and many other areas deemed to be ecologically sensitive or environmentally critical will, in most instances, be precluded from having a transmission line routed through them. Such distinctively classified areas contain natural resources or other cultural and historic features that are viewed as having special values and status, and are to be preserved and protected from irreparable damage.

Unauthorized access to the ROW via all terrain vehicles (ATVs) and the use of other off-highway motorized vehicles (e.g., 4X4s and snowmobiles) and additional vehicles (mountain bikes) on the ROW access roads by recreational users could cause trespass-related impacts. These can cause an increase in litter and noise, as well as illegal hunting and dumping.

Lands with conservation easements which are crossed by an overhead transmission line (if allowed under the easement) require an assessment by the administrator of the conservation easement regarding the adverse impacts from the construction, operation, and maintenance of the line. The organization holding the conservation easement may require specific rehabilitation or restoration of the property. In the worst case, the property may no longer meet the requirements of the conservation easement, in which case it would be rescinded.

Projects crossing parks, and recreation and preservation areas, which received grant funding from the Land and Water Conservation Fund can require the granting of a ROW across the property. If the project requires a conversion of land, this would constitute a conflict with the Land and Water Conservation Fund and may not be possible.

### **3.3.6 Parks, Recreation, and Preservation – Underground Line Impacts**

Impacts to parks, recreation and preservation areas from construction, operation, and maintenance of an underground 500-kV transmission line would be similar to impacts from an overhead 500-kV transmission line with the following exceptions.

Since the underground ROW has minimal vegetation, this may increase unauthorized access to the ROW via all terrain vehicles (ATVs) and other off-highway motorized vehicles (e.g., 4X4s and snowmobiles) and other modes of transportation (mountain bikes) resulting in trespass-related impacts. These can cause an increase in litter and noise, as well as illegal hunting or dumping.

Underground transmission lines lack overhead structures with the exception of the two transition points, which lessen the visual impact on special management areas. However, maintenance of the ROW in certain areas could be negative due to the creation of differences in vegetation. For example, an underground transmission line installed through a forested area requires the elimination of trees during construction and ROW maintenance, thus disrupting the visual continuity of the forest.

---

<sup>1</sup> However, the Wilderness Act of 1964 includes a special provision for the establishment of transmission lines within or across a Wilderness Area that is located within a national forest. Section 4(d) provides the following text regarding these transmission lines: Within wilderness areas in the national forests designated by this chapter, the President may, within a specific area and in accordance with such regulations as he may deem desirable, authorize prospecting for water resources, the establishment and maintenance of reservoirs, water-conservation works, power projects, transmission lines, and other facilities needed in the public interest, including the road construction and maintenance essential to development and use thereof, upon his determination that such use or uses in the specific area will better serve the interests of the United States and the people thereof than will its denial (Public Law 88-577, Section 4[d]).

---

There would be no noise impacts from operation of the underground transmission line.

A frac-out event, as well as fluid leaks may disrupt and/or destroy adjacent parks, recreation, and preservation resources through the displacement of subsurface soils onto the land surface and result in soil contamination. Any required clean-up activities may also disrupt these resources.

Trenchless installation methods, such as directional drilling, may be able to preserve the above-ground parks, recreation, and preservation resources. Temporary disturbance may occur around the entry and exit pit(s) from equipment and workers. Permanent disturbance would occur at the entry and exit pit areas as vegetation removal would be required for permanent access to this area.

### **3.3.7 Residential – Overhead Line Impacts**

Depending upon the proximity to the facility, and the intervening vegetation and other viewing limitations, residential occupants may be able to see the conductors and/or the support structures. In the foreground view area, poles are often preferred over lattice towers while steel lattice towers are preferred when viewing at a distance or in the background view area. If the residences are located within a few yards of the ROW, they may hear noise from corona discharge when the lines are wet.

The removal of existing buildings, including residential dwellings and related structures, might be required for a project ROW, as they might be incompatible with construction, operation, and maintenance of an overhead transmission line. The location of the project ROW within platted subdivisions can preclude or impair future development or planned activities.

### **3.3.8 Residential – Underground Line Impacts**

The removal of existing buildings, including residential dwellings and related structures, would be required for a project ROW using trenching methods, since they are incompatible with construction, operation, and maintenance of an underground transmission line. The location of the project ROW within platted subdivisions can preclude or impair future development or planned activities.

There would be no noise impacts from operation of the underground transmission line.

A frac-out event, as well as fluid leaks, may disrupt and/or destroy adjacent residences through the displacement of subsurface soils onto the land surface and result in soil contamination. Any required clean-up activities may also disrupt residences.

### **3.3.9 Commercial – Overhead Line Impacts**

Buildings of any kind are directly incompatible with a high voltage electric transmission line ROW. Lines are purposefully routed around large buildings or commercial complexes. Lone or small commercial facilities may need to be removed if they end up being within a ROW, much like single residential buildings, if no other routing alternatives are economically viable. However, many 500-kV transmission lines are located over outdoor storage areas on lands classified as commercial. Parking lots surrounding many commercial establishments are likewise often compatible adjacent land uses, depending upon the presence and height of lights and other factors.

Impacts to people who work and visit commercial areas would be similar to residential impacts as described in the residential overhead section.

---

### **3.3.10 Commercial – Underground Line Impacts**

The removal of existing buildings including commercial buildings and related structures would be required for a project ROW using trenching methods since they are incompatible with construction, operation, and maintenance of an underground transmission line. The location of the project ROW can preclude or impair future commercial development or planned activities.

There would be no noise impacts from operation of the underground transmission line.

A frac-out event, as well as fluid leaks, may disrupt and/or destroy adjacent commercial properties through the displacement of subsurface soils onto the land surface and result in soil contamination. Any required clean-up activities may also disrupt commercial properties.

### **3.3.11 Public Facilities – Overhead Line Impacts**

Major public building and institutional structures are often avoided during the routing of lines, and larger buffer zones are sometimes used around these facilities (e.g., schools) (French et al., 2008). The removal of existing buildings including public facilities and related structures might be required for a project ROW as they could be incompatible with construction, operation, and maintenance of an overhead transmission line. The location of the project ROW can preclude or impair future public facility development or planned activities.

Impacts to people who work and visit public facilities would be similar to residential impacts described in the residential overhead section.

### **3.3.12 Public Facilities – Underground Line Impacts**

Generally, city parks and city/county-owned properties like public education land areas are deemed unacceptable for underground transmission lines, but the removal of existing buildings including public facilities and related structures would be required for a project ROW using trenching methods since they are incompatible with construction, operation, and maintenance of an underground transmission line. The location of the project ROW can preclude or impair future public facility development or planned activities.

There would be no noise impacts from operation of the underground transmission line.

A frac-out event, as well as fluid leaks, may disrupt and/or destroy adjacent public facilities through the displacement of subsurface soils onto the land surface and result in soil contamination. Any required clean-up activities may also disrupt public facilities.

### **3.3.13 Industrial – Overhead Line Impacts**

Due to the often long-term industrial nature of these properties, potential problems may be encountered when attempting to build a transmission line over and/or in an industrialized area. Previously unknown soil contamination associated with industrial contamination (e.g., solvents, hydrocarbons, heavy metals, etc.) could be encountered during substation or access road grading or excavation of support structure sites, potentially affecting the health of workers or the public. During grading or excavation work in such industrial environments, diligent efforts must be made to observe the exposed soil for visual evidence of contamination. If visual contamination indicators are observed during construction, all work must stop until the material is properly characterized and appropriate measures are taken to protect human health and the environment. The utility must comply with all local, state, and federal requirements for sampling



---

and testing, and subsequent removal, transport, and disposal of these hazardous wastes (California Public Utilities Commission and DOI, 2006).

Intensive land uses such as major mineral extraction activities and most active mining is difficult to route a transmission line through because of heavy equipment activity, worker safety, potential excavation around structure bases, waste stockpiling, and mining material between structure spans decreases safety heights from conductor to ground. However, limited scale mining activities, such as gravel pits and some quarry operations, can be spanned. No surface blasting is allowed under or near conductors and support structures. Construction of a 500-kV transmission line over areas of known mineral assets can render these resources inaccessible.

### **3.3.14 Industrial – Underground Line Impacts**

Trenching activities may encounter unknown soil contamination associated with industrial uses potentially affecting the health of workers and/or the public as described under the Impacts to Industrial Areas from Underground Construction section above.

The removal of existing buildings, including occupied dwellings and related structures, would be required for a project ROW using trenching methods since they are incompatible with construction, operation, and maintenance of an underground transmission line. The removal of existing buildings may not be required for a project ROW using trenchless methods. The location of the project ROW can preclude or impair future industrial development or planned activities.

Underground transmission lines may be incompatible with some industrial land uses such as mines, gravel pits, and landfills as the ROW would become inaccessible and unusable for such activities.

There would be no noise from the underground transmission line.

A frac-out event, as well as fluid leaks, may disrupt and/or destroy adjacent industrial properties through the displacement of subsurface soils onto the land surface and result in soil contamination. Any required clean-up activities may also disrupt industrial properties.

### **3.3.15 Transportation and Access – Overhead Line Impacts**

Transportation and access impacts will be temporary during construction of an overhead 500 kV transmission line. Construction of the project may result in roadway closures at locations where the construction activities are within ROW of public streets and highways. Construction vehicles might have to utilize public and private roads to access the transmission line ROW during construction, which increases dust, noise, and overall traffic in the short term. If public and private roads are used, long-term impacts are minimal from vehicles accessing the ROW for periodic maintenance of the ROW and/or overhead transmission line.

Construction activities can interfere with emergency response by ambulance, fire, paramedic, and police vehicles. Potential roadway segments most impacted are two-lane roadways, which provide one travel lane per direction. On roadways with multiple lanes, the loss of a lane, and the resulting increase in congestion, can lengthen the response time for emergency vehicles to pass through the construction zone. Additionally, it is possible that emergency services may be needed at a location where access is temporarily blocked by the construction zone.

There is potential for damage to roads by vehicles and equipment entering and leaving the project area. An increase in trips can damage roads because of the increased weight, which is especially of concern in

---

areas with greater amounts of rain and freezing. Project construction temporarily increases traffic (project trip generation) on adjacent roads and highways, which can create problems when there are increases in traffic due to tourism. Depending on location, construction personnel will likely access worksites using primary and secondary roadways in the project area. The impacts on roads are short term and related to the movement of personnel and equipment during construction.

### **3.3.16 Transportation and Access – Underground Line Impacts**

Impacts to transportation and access from construction, operation, and maintenance of an underground 500-kV transmission line would be similar to impacts from an overhead 500-kV transmission line with the following exceptions.

With the use of trenching methods, an unimpeded path suitable for heavy excavation equipment is required along the entire cable ROW to provide access for maintenance and repair crews. This may reduce the need for access roads to the ROW and reduce impacts to transportation, particularly during operation and maintenance activities.

Installation of a transmission line using trenching methods may disrupt transportation and access to properties to a large degree because of the amount of ground disturbance required for trenching. Installation of a transmission line using trenchless methods, such as directional drilling, may not disrupt transportation or access at all or to a very small degree if the project is drilling underneath a highway, street, or road.

A frac-out event, as well as fluid leaks, may disrupt and/or destroy adjacent transportation or access resources through the displacement of subsurface soils onto the land surface and result in soil contamination. Any required clean-up activities may also disrupt transportation and access.

### **3.3.17 Land Use Mitigation Techniques**

The following mitigation techniques could be used to minimize impacts on land use resources during construction, operation, and maintenance of an overhead and/or underground 500-kV transmission line. For vegetation management mitigation techniques, see section 3.10.

1. Repair or replace existing property improvements to the original condition prior to disturbance if they are damaged or destroyed by construction activities.
2. Install, repair, or replace fences and gates to their original condition prior to disturbance if they are damaged or destroyed by construction activities. Close or lock gates as agreed to by landowners.
3. Leave existing roads used for construction in a condition equal to or better than their pre-construction condition.
4. Project facilities, including structures and access roads, can be installed along property lines or in the location that creates the least potential for impact to the property or adjacent properties and their uses.
5. Locate construction staging areas next to existing roads, when practical.
6. Make appropriate arrangements with landowners to remove livestock where necessary.

- 
7. Coordinate with farmers to ensure access to livestock feeding and watering stations, as well as continued access across the ROW for farm equipment.
  8. Limit new or improved accessibility into the area by off-highway and other motorized vehicles by coordinating with the appropriate agencies and underlying landowners. Physically close appropriate roads using boulders, tank traps or gates.
  9. Do not apply paint or permanent discoloring agents to rocks or vegetation to indicate survey limits or construction activity.
  10. At residences, align the ROW to the main road to reduce impact on the residences whenever possible.
  11. Compensate landowners for short-term use and damages associated with construction activities.
  12. Use warning signs at all designated trail and roadway crossings, and station flaggers during construction for all state, federal, county, and local roads and highways. Identify appropriate detour routes for local road users.
  13. Notify all utilities of construction to incorporate their facility location on the construction drawings. Prior to construction, flag and/or stake the locations of all utility lines.
  14. Obtain necessary and appropriate land use permits.
  15. Time construction activities, whenever practical, to minimize disruption of normal seasonal activities for agriculture (planting and harvesting) and non-irrigated rangeland as well as avoid peak-use periods (e.g., weekends and holidays) at parks, recreation, and preservation areas. Coordinate construction activities with relevant agencies and landowners prior to construction.
  16. Provide advance notice of construction, operation or maintenance activities to landowners and residents potentially affected by these activities. Provide adequate access to existing land uses during periods of construction and, notify landowners of alternative access. Avoid nighttime construction near noise-sensitive land uses (e.g., residences and campers at recreation sites).
  17. When possible, avoid construction and operation disturbance of agricultural soil during the wet season. Minimize the use of heavy equipment on agricultural land to avoid soil compaction. Reduce the amount of soil compaction by working when the ground is frozen, using equipment with additional and wider tires to distribute the weight of the vehicle. Till severely compacted areas after construction is completed.
  18. Obtain required encroachment permits or similar legal agreements for each affected roadway. Such permits may be needed for roads crossed by the transmission line, as well as for parallel roads where transmission line construction activities require the use of the public ROW (e.g., temporary lane closures).
  19. Coordinate in advance with emergency service providers to avoid restricting movements of emergency vehicles. Have local agencies notify respective police, fire, ambulance, and paramedic services. Notify local agencies of the proposed locations, nature, and duration of any construction activities, and advise of any access restrictions that impact their effectiveness.

- 
20. Project design and construction should comply with applicable regulations associated with railroads/railways in the project area. Obtain required permits for entering railroad ROW from the appropriate railroads/railways.
  21. Coordinate with agricultural landowners to ensure subsurface tower structures will not interfere with blading or tilling activities, where feasible.
  22. Use existing public roads to the extent possible when performing construction, operation, and maintenance activities. Use dust-control measures in sensitive areas, as needed, when performing access road maintenance.
  23. Avoid vehicle traffic on the ROW except as needed to maintain the ROW and for transmission line maintenance and repair.
  24. Restrict all operation and maintenance vehicle movement outside the ROW to pre-designated access or public roads.
  25. Develop and follow an appropriate maintenance program for transmission line systems and ROW.

### **3.4 Biological Resources**

Constructing, operating, and maintaining a 500-kV transmission line without disrupting, changing or destroying biological resources can be a challenge, although some areas are more sensitive than others due to the type of resource. Rare, threatened, and endangered species and habitats are particularly susceptible to negative impacts from construction, operation, and maintenance of a 500-kV transmission line. The impacts to biological resources are discussed below and are divided into two categories: vegetation resources and wildlife resources.

#### **3.4.1 Vegetation Resources**

Vegetation resource impacts from construction, operation, and maintenance of a 500-kV transmission line can result in the following:

- Disruption of existing vegetation
- Change in habitat type or vegetation composition
- Habitat fragmentation
- Disruption of rare, threatened, and endangered plant species and habitat
- Introduction of invasive plant species

##### **3.4.1.1 Disruption of Existing Vegetation from Overhead Lines**

At a minimum, all woody vegetation must be removed from access road locations, structure sites, equipment storage areas, and assembly work areas. The access roads and structure sites require complete clear cutting of all vegetation. Typically the construction contractor will find an open field, existing storage yard or graveled parking lot for equipment storage areas, which would not require vegetation clearing, but the disturbance could be significant because of the level of equipment activity. However, ROW locations can be more selectively cleared to remove only the tall-growing species (virtually every tree as well as some tall-growing shrubs) found within the ROW. In this general ROW situation, most shrubs can be left, along with all herbaceous vegetation. In some other special ROW locations, such as

---

roadside screens and streamside buffer zones, clearing can be more selective as to require only the removal of vegetation over a certain height.

The critical height over which the vegetation must be removed in these special consideration areas is dependent on the distance of the conductor to the vegetation at each specific location. Greater conductor clearances may allow the retention of more trees (e.g., many low-stature trees and tall shrubs) for a greater period of time. As the remaining trees continue to grow they will have to be trimmed, or most likely removed in the future. This leisurely removal will allow other vegetation to invade the buffer zone or screen, some of which will be low-growing species that will be perpetually retained. In other ROW situations where exceptional ground-to-conductor clearances exist, (such as in deep ravines and gullies, valley bottoms, or gorges and canyons), all vegetation can often be retained.

Other disruption factors affecting existing vegetation are the chosen methods of log handling and slash disposal. Often, trees felled on the ROW are limbed and topped. The remaining logs are then moved to piles at a ROW location from which merchantable timber products can be easily extracted. The remaining slash materials are bunched into piles and sometimes windrowed along the outside edges of the ROW. In clearing situations that are located on steep slopes or where tree density is light, the felled trees are bucked, topped, limbed, and further lopped into smaller pieces and scattered about the ROW. Other disposal methods may include burning the slash, and chipping or carting it away for off-site disposal. Vehicular movement for the transport of logs and the handling of slash can often scarify the ROW soils to some extent.

Vegetation resources may be impacted by operation and maintenance activities due to heavy-duty maintenance vehicles and equipment leaving established access roads and crushing plants. Vegetation may also be impacted when accidental oil or fuel spills occur. Road maintenance activities can result in reduction or removal of streamside vegetation through brushing activities, possibly resulting in water temperature increases. The risk of temperature increases is highest in very small streams. Road maintenance involving brush removal can reduce stabilizing vegetation on both cut and fill slopes, contributing to erosion impacts.

The purpose of vegetation management activities associated with transmission line ROW is to remove or cut intrusive vegetation (target vegetation) growing on or near the ROW. Target vegetation includes trees and shrubs growing in the ROW or off the ROW that can grow into, fall into, or otherwise interfere with transmission lines. The same is true for underground transmission ROW. A properly maintained underground ROW must be kept clear of trees and large shrubs that could interfere with the underground line directly (with their roots) or indirectly (by removing soil moisture needed to adequately cool the conductors) (Wisconsin Public Service Commission, 2004). Non-target vegetation can also be impacted by general vegetation management activities including accidental trampling or killing of plant species, increased exposure to sunlight and weather, increased noxious weed growth, and/or changes in soil nutrient levels and soil moisture.

### **3.4.1.2 Disruption of Existing Vegetation from Underground Lines**

Impacts to vegetation resources from construction, operation, and maintenance of an underground 500-kV transmission line would be similar to impacts from an overhead 500-kV transmission line with the following exceptions.

Trenching activities disrupts the existing vegetation no matter what type of vegetation exists. Trenching can damage the root systems of existing trees next to the ROW to the extent that the trees are weakened or killed. A properly maintained underground ROW must be kept clear of trees and large shrubs because they could interfere with the underground line directly (with their roots) or indirectly (by removing soil

---

moisture that is needed to adequately cool the conductors) (Wisconsin Public Service Commission, 2004). Trees and large shrubs cannot be re-planted in the ROW of underground transmission lines; however, grass or similar vegetation may be used.

Trenchless methods, such as directional drilling, will not disrupt the existing vegetation to the extent of trenching because the vegetation will remain intact. Temporary disturbance may result from equipment and workers near the exit and entry pits and permanent disturbance of existing vegetation would result from excavation of the pits and permanent access to these locations.

A frac-out event, as well as fluid leaks, may disrupt and/or destroy vegetation resources through the displacement of subsurface soils onto the land surface and result in soil contamination. Any required clean-up activities may also disrupt and/or destroy vegetation resources both within and outside the ROW.

### **3.4.1.3 Change in Habitat Type or Vegetation Composition from Overhead Lines**

Changes in habitat types or vegetation composition can occur within the transmission line ROW, but results may vary significantly depending on the type of habitat being impacted. Also, vegetation recovery rates will depend on soil type, landform, precipitation regime, and other physical features of the disturbed sites.

Vegetation removal operations for overhead transmission lines largely depend on the height of the natural vegetation present and the ground to conductor clearances. Forests will by necessity usually be substantially and permanently altered (over the life of the line) to form a variety of low-growing, sun-loving, early successional plant communities. Some shrub communities, as well as old-field vegetation, can remain almost entirely intact (except at structure sites and access roads). Rangeland, grasslands, and many desert plant communities can be virtually unaffected from general ROW clearing, as none would be needed. Also, areas containing only short stature trees, such as a juniper and pinion pine forest, might coexist within the ROW. Only a few taller specimens may need to be removed from under the maximum sag portion of the line due to the general low height and slow growth rate of these and similar species.

More studies need to be conducted in this area, but a lack of native species recovery exists in certain ecosystems where areas are severely disturbed such as clearing of the ROW and installation of overhead transmission line structures and components, as indicated in the following studies.

In the Mojave Desert, Lathrop and Archbold discovered that disturbed areas from transmission line construction and control areas may appear to have similar vegetation covers, biomasses, and densities, but the similarities often vanished when qualitative aspects were examined, such as proportion of long-lived species and presence of characteristic dominants (Lathrop & Archbold, 1980).

A study by Thibodeau and Nickerson revealed that overhead transmission line construction did not have a substantial, long-term negative impact on a forested wetland. Except for differences in size and maturity, the forested wetland vegetation recovered in two years from nearly total destruction caused by construction (Thibodeau & Nickerson, 1986). A similar study examined the response of vegetation communities to overhead transmission line construction in three different wetland types: a cattail marsh, a forested swamp, and a shrub/bog wetland. While both the cattail marsh and forested swamp recovered within a few years, measures of plant community composition in the shrub/bog wetland were still lower, compared to controls after ten years (Nickerson, Dobbertein, & Jarman, 1989).

Stylinski and Allen investigated the impacts of severe disturbance (construction, heavy-vehicle activity, soil excavation, landfill operation, and tillage) on shrub communities in southern California. Their study

---

revealed that these disturbances led to the conversion of indigenous shrublands to exotic annual communities with low native species richness. The cover of native species remained low on disturbed sites even 71 years after initial disturbance ceased. The study supported their hypothesis that altered stable states can occur if a community is pushed beyond its threshold of resilience (Stylinski & Allen, 1999).

It may be concluded from these studies that certain ecosystems are more resilient than others to disturbance caused by overhead transmission line construction, and that permanently altered vegetation communities can occur if pushed beyond their thresholds of resilience. Shrub/bog wetlands, as well as arid and semi-arid ecosystems, appear to be particularly susceptible to permanent damage from overhead transmission line construction.

Additionally, because the vegetation composition within the ROW must be kept free of large trees and shrubs, a permanent early successional habitat is created. The creation of these open and early successional habitats in a ROW is beneficial to some species and detrimental to others.

Creation of early successional plant communities composed of an assortment of locally extant and readily available low-growing native woody shrubs, herbs (forbs and grasses/sedges), ferns, vines, reeds, and other forms of plant life can be positive if the ROW is located in a predominately forested setting. These ROW conditions replicate old-field plant communities that are becoming landscape rarities in many locations, thereby increasing or restoring this unique vegetation community. The juxtaposition of these two different plant community types; one a forest and the other a mixture of low growing plants, creates a unique transition area from one habitat type to another where rare plants might thrive. In general, when a ROW is created within a region that is primarily forested, the benefits of this new unique habitat along with the “edge effect” may be positive overall as seen with the Karner Blue Butterfly described below.

In Wisconsin, transmission ROW has a positive effect on the federally endangered Karner Blue Butterfly, where blue lupine, a plant vital to the butterfly’s survival, is increasing in abundance because of the open areas in the overhead transmission line ROW (Willyard et al., 2004). The Karner Blue Butterfly serves as an example of a positive outcome of ROW corridors.

#### **3.4.1.4 Change in Habitat Type or Vegetation Composition from Underground Lines**

Impacts due to changes in habitat type or vegetation composition from construction, operation, and maintenance of an underground 500-kV transmission line would be similar to impacts from an overhead 500-kV transmission line with the following exceptions.

With trenching methods, all vegetation would be removed from installation of the trench and transmission line, and the remainder of the ROW would need to have low growing vegetation to provide access for maintenance vehicles. This may create a relatively uniform habitat type and reduced species diversity than existed prior to construction.

With trenchless methods, such as directional drilling, there would be no changes to the existing habitat type or vegetation composition because the surface soil and vegetation would not be disturbed.

#### **3.4.1.5 Habitat Fragmentation from Overhead Lines**

Habitat fragmentation can occur with construction of an overhead 500-kV transmission line, but results will vary depending on the plant species composition both within the ROW and adjacent to it. Impacts seem to be species-specific and localized. Whether or not the ROW provides a net ecological benefit, the “edge effect,” or constitutes an ecological threat in the form of fragmentation, is dependent on the overall

---

landscape conditions surrounding the ROW and cannot be discerned solely by the sheer presence of the ROW or by the condition of the vegetation on the ROW alone (Albrecht et al., 2000).

The literature on the ecological impacts of fragmentation focuses on reduced habitat area, species isolation, and increased habitat edge. Plants that are isolation, area, or edge sensitive will be negatively affected by fragmentation; however, plants that are not sensitive to fragmentation may be unaffected or positively affected by the separation if it results in an increase in habitat or favorable conditions for these species.

With regard to reduced habitat area, a survey of twenty transmission line corridors in the forests of northern Kentucky reveals that construction of a single power line corridor within forests, already fragmented by development activities, may render forest patches unsuitable for plant species requiring large forest interior habitats (Luken et al., 1990).

The habitat fragmentation impacts of roads on the landscape include dissecting vegetation patches, increasing the edge-affected area, decreasing interior area, and increasing the uniformity of patch characteristics, such as shape and size (Reed et al., 1996).

#### **3.4.1.6 Habitat Fragmentation from Underground Lines**

Impacts due to habitat fragmentation from construction, operation, and maintenance of an underground 500-kV transmission line would be similar to impacts from an overhead 500-kV transmission line with the following exceptions.

Trenchless methods would not disturb the existing habitat so impacts to habitat fragmentation would be low except for the areas where entry and exit pits are needed, as all vegetation would be removed from these areas for installation and permanent access. Trenchless methods may still result in impacts from habitat fragmentation unless the entire transmission line is completed using trenchless methods.

#### **3.4.1.7 Disruption of Rare, Threatened, and Endangered Species and Habitats from Overhead Lines**

Direct and indirect impacts to plants that are listed as threatened and endangered species are a major environmental concern when building a new 500-kV transmission line. This is because of the official status given these plants due to their low population numbers and the general tendency for such listed species to be less resilient to habitat alterations than other more commonly found plants. Other plant species may be considered as rare in a given area for having low population numbers, a very narrow endemic range, and/or fragmented habitat. In some instances these rare plants are provided various types of protection (e.g., protected plants) by state or local laws, or are otherwise considered a species of concern for various reasons. Temporary disturbances can have adverse impacts on plant populations with very limited ranges. Specific impacts are dependent on the exact species status within or near the proposed ROW and other habitat requirements with respect to the location of particular project activities.

Roads and ROWs create habitat edge, particularly in forested settings, which enhances local plant species diversity and has a positive effect on some individual species, typically those that are habitat generalists and are already common in the landscape. As a result, increased local diversity often comes at the expense of global species diversity, as rare plants are replaced by common ones. This phenomenon causes ecosystems to lose complexity (Willyard, 2004). Although, it is possible that rare and unique plant species may take the opportunity to exploit the newly created ecological niches and, to the extent



---

that some may be protected listed plants, the presence of the ROW may actually induce the occupancy of these species of concern.

Rare plant species may also be affected by the introduction of invasive plant species, not only in the ROW, but also near the edges of the ROW, if the invasive species encroach into these areas.

#### **3.4.1.8 Disruption of Rare, Threatened, and Endangered Species and Habitat from Underground Lines**

Impacts to rare, threatened, and endangered plant species and habitat from construction, operation, and maintenance of an underground 500-kV transmission line would be similar to impacts from an overhead 500-kV transmission line with the following exceptions.

Trenchless methods, such as directional drilling, will not disrupt the rare, threatened, and endangered plant species to the extent of trenching because the vegetation will remain intact. Temporary disturbance may result from equipment and workers near the exit and entry pits, and permanent disturbance of existing vegetation would result from excavation of the pits and permanent access to these locations.

A frac-out event, as well as fluid leaks, may disrupt and/or destroy rare, threatened, and endangered plant species through the displacement of subsurface soils onto the land surface and result in soil contamination. Any required clean-up activities may also disrupt and/or destroy these special status plant species both within and outside the ROW.

#### **3.4.1.9 Introduction of Invasive Plant Species - Overhead Lines**

Noxious weeds and invasive plants can pose serious threats to the composition, structure, and function of native plant communities (Olson, 1999). Noxious weeds produce abundant seed, have fast growth rates, and can displace native species (Olson, 1999). Project activities that disturb the ground and the subsequent loss of native vegetation can make an area vulnerable to noxious weed invasions (Olson, 1999). In addition, open roads can serve as corridors for weed spread. Noxious weed seeds can be carried in the undercarriage of vehicles and distributed along roadway; the movement of animals or humans can facilitate the spread of invasive species into previously inaccessible areas. Invasive species monopolize ecosystems and often out-compete native vegetation, which in turn negatively affects the animals dependent on these habitats.

A study in the southern California shrublands found that sites with severe disturbance from activities such as soil excavation and heavy-vehicle equipment consisted of 60 percent non-native annual species compared with undisturbed sites that were primarily covered with native shrub species (68 percent) (Sylinski & Allen, 1999).

Clearing of new ROW may open fresh environments for these deleterious plant species (alien, exotic, non native species that are invasive and may be listed as noxious weeds that also may be legally classified as undesirable) to occupy. Although 500-kV transmission lines corridors are often viewed as a potential habitat and/or corridor for movement of invasive species, they do not, in most cases, undergo the degree of continuous disturbance that many exotic invasive species seem to prefer. Although, if invasive plant species are not controlled within the ROW, their populations may increase, thus displacing more native vegetation.

---

### **3.4.1.10 Introduction of Invasive Plant Species – Underground Lines**

Impacts due to introduction of invasive plant species from construction, operation, and maintenance of an underground 500-kV transmission line would be similar to impacts from an overhead 500-kV transmission line with the following exceptions.

Since underground installation requires continuous disturbance along the length of the trench and the ROW requires plants with minimal root systems and little variety, this has the potential of enhancing the establishment of invasive plant species.

Trenchless methods will not disrupt the existing vegetation; thereby, reducing the introduction of invasive species. Temporary disturbance may result from equipment and workers near the exit and entry pits. Permanent disturbance of existing vegetation would result from excavation of the pits and permanent access to these locations, creating opportunities for invasive species to get established.

### **3.4.2 Wildlife Resources**

Many of the major impacts to wildlife resources associated with overhead transmission lines are connected with ROW preparation and transmission line, substation, and access road construction. Impacts to wildlife resources from these activities could result in the following:

- Habitat and population fragmentation
- Habitat loss and reduced species abundance
- Wildlife displacement and disturbance
- Disruption of rare, threatened, and endangered species
- Herbicide toxicity
- Avian interactions (overhead only)

#### **3.4.2.1 Habitat and Population Fragmentation from Overhead Lines**

Concern for habitat fragmentation is increasing in wildlife management (Baker & Knight, 2000) and is considered a global concern for biological diversity (Knight et al., 2000). Species decline and shifts of animal distributions have led to a more modern focus on the causes of habitat fragmentation and the effect this may have on wildlife. Avian responses to habitat fragmentation included life cycle alterations, increased parasitism, and habitat affinity associations (Weller et al., 2002; Knight et al., 2000). Habitat removal and fragmentation as a result of transmission line construction can alter wildlife migration corridors and dispersal orientation, and isolate wildlife populations and their gene pools. This significantly weakens the wildlife community.

The impacts of fragmentation by roads may be similar to that of fragmentation by a ROW. Fragmentation by roads is known to change landscape structure, directly and indirectly affecting species. Road-avoidance behavior is characteristic of large mammals such as elk, deer, bighorn sheep, grizzly, and wolf. Avoidance distances of 100 to 200 meters are common for these species (Lyon, 1983). Road density is a useful index for the effect of roads on wildlife populations (Forman et al., 1997). Some studies show that a few large areas of low-road density, even in a landscape of high average road density, may be the best indicator of suitable habitat for large vertebrates (Rudis, 1995).

There is strong evidence that forest roads displace some large mammals and certain birds (such as spotted owls and marbled murrelets), and that displaced animals may suffer habitat loss as a result. Impacts of

---

roads on small mammals and songbirds are generally described as less severe, with changes expressed as modifications of habitat that cannot readily be classified as detrimental or beneficial.

Roads and ROW also create habitat edge (Mader, 1984; Reed et al., 1996); increased edge changes habitat in favor of species that use edges, referred to as edge specialists. The introduction of edge specialists is often to the detriment of species that avoid edges or experience increased mortality near or along edges, referred to as habitat interior specialists (Marcot et al., 1994). The continuity of a road system or ROW can create a corridor by which edge-dwelling species of birds and animals can penetrate the previously closed environment of continuous forest cover. Species diversity can increase, and increased habitat for edge-dwelling species can be created.

In general, road building and ROW clearing fragments habitat, and creates habitat edge, modifying the habitat in favor of species that use edges. Edge-dwelling species are generally not threatened, however, because the human-dominated environment has provided ample habitat for them.

Habitat removal and fragmentation as a result of road or ROW clearing can alter wildlife migration corridors and dispersal orientation, as well as isolate wildlife populations and their gene pools. This significantly weakens the wildlife community.

Habitat fragmentation affects wildlife regardless of the location, but the degree to which wildlife is affected, and the species-specific impacts, as they relate to construction of an overhead transmission line cannot be definitely concluded. Construction of access roads directly applies, but construction of the ROW, while similar to a road, is dissimilar enough that direct comparison may be less effective. Roads completely remove all vegetative matter and thus nearly all wildlife habitats, while a ROW is allowed to return to a state resembling pre-construction depending upon the pre-construction habitat.

### **3.4.2.2 Habitat and Population Fragmentation from Underground Lines**

Impacts to habitat and population fragmentation from construction, operation, and maintenance of an underground 500-kV transmission line would be similar to impacts from construction of an overhead 500-kV transmission line with the following exceptions.

Underground transmission lines may not fragment grassland habitat if the grassland habitat is allowed to return to a pre-construction state.

Trenchless methods would not disturb the existing habitat so impacts due to habitat and population fragmentation would be low except for the areas where entry and exit pits are needed as all vegetation and nearly all wildlife habitats would be removed from these areas for installation and permanent access. Trenchless methods may still result in impacts from habitat and population fragmentation due to ROW preparation unless the entire transmission line is completed using trenchless methods.

### **3.4.2.3 Habitat Loss and Reduced Species Abundance from Overhead Lines**

Direct habitat losses can result from the conversion of existing wildlife habitat to access road surfaces and other transmission facilities requiring nearly bare ground. Also, one existing habitat type (e.g., a forest) may be lost as a result of some ROW preparation activities (e.g., selective clearing), as the habitat may be converted or changed (e.g., to a shrubland). In general, wildlife species abundance will decline with any reduction in the size or quality of the habitat. The extent that ROW habitat conversion (e.g., from forest to shrubland) may result in reduced wildlife species abundance will depend on the amount of fragmentation already existing in the landscape and exactly what types and amounts of habitat are being lost or gained. If the general landscape surrounding the ROW is already fragmented, then additional

---

fragmenting will only serve to exacerbate the problem. If there is a nearly continuous or extensive habitat type covering the region (e.g., forests), creation of the ROW and its attendant edge may add a new desired disturbance regime to the locale. Thus the newly created ROW can have a positive effect for early successional species by providing a new, but distinctly unique habitat (i.e., a low-growing habitat that is early successional in nature and generally sun loving). In this instance, early successional species will thrive, but habitat interior specialists will suffer negative impacts and will cease to exist in and around the ROW.

As the number of fragments increase in a given area, the core area size used by interior habitat specialists decreases, reducing the patches uninterrupted by human disturbance. The amount of edge area grows with the increase of fragments, and habitat connectivity decreases with increased fragmentation (Knight et al., 2000). Decreased connectivity may favor the habitat generalist wildlife species over the forest or grassland specialist species, threatening species richness or diversity at regional scales (Knight et al., 2002). Habitat generalists, such as coyotes, skunks, raccoons, and brown-headed cowbirds, use road corridors and ROW to easily access the interior forest or grassland. These predators and nest parasites can have direct impacts on interior habitat adapted species populations. Opening up forest, and to a lesser degree shrubland habitat, also increases solar exposure during winter months creating earlier forage exposure for several species.

Vegetation control activities also have a potential impact on aquatic life in areas where the ROW crosses over or is adjacent to riparian zones. Riparian plants and trees provide food for fishes and other animals, and habitats for insects that supplement fish diets. Riparian vegetation also provides shade to maintain cool stream temperatures and insulate the stream from heat loss in winter.

The loss of riparian vegetation is a long-term, direct impact of ROW vegetation management activities. When riparian vegetation is removed or pruned, stream shading is immediately reduced, resulting in stream temperature increases. Erosion impacts occur when soil-stabilizing riparian vegetation is removed. Erosion increases turbidity and sedimentation, potentially impacting fish feeding success. In some cases, increased sedimentation can keep fry from emerging or it can fill in deeper pools preferred by some fish species.

However, one study conducted on a forested transmission ROW in New York found a greater abundance of fish associated with ROW streams than in nearby forested streams (Peterson, 1993). The study suggests that tree canopy removal in the ROW increased sunlight in the riparian zone. This facilitated dense low-growing vegetation to grow on stream banks, which stabilized stream bank soils, minimizing erosion. In contrast, the forested stream banks were largely vegetation free, which contributed to erosion related impacts.

Insects used for biological control of undesirable vegetation may act as a food source, enhancing habit for birds and other wildlife.

#### **3.4.2.4 Habitat Loss and Reduced Species Abundance from Underground Lines**

Impacts to habitat loss and reduced species abundance from construction, operation, and maintenance of an underground 500-kV transmission line would be similar as impacts from construction of an overhead 500-kV transmission line with the following exceptions.

With trenching methods, riparian areas are typically avoided, but in the instance where they may be disrupted by installation of an underground transmission line, there may be a large impact from the loss of riparian habitat and species.

---

### **3.4.2.5 Wildlife Displacement and Disturbance from Overhead Lines**

Construction, operation, and maintenance of transmission lines, underground or overhead, may provide temporary or permanent wildlife disturbance by displacing animals from their typical habitat. Disruption comes from increased noise levels (e.g., construction); increased vehicle traffic (e.g., construction, maintenance, recreation use); and facility presence (e.g., tower structures, manholes, access roads, and pad-mounted equipment). Helicopter patrols can adversely affect wildlife, particularly big game species during birthing periods (Bridges et al., 1997). Most wildlife occupying a project area are displaced during construction, and some species such as nesting birds and amphibians, are vulnerable to mortality from the physical disruption of soils and vegetation.

Impact to fisheries can result from increased sediment in streams or rivers. Potential impacts are greatest during and immediately after construction. Fish tend to avoid streams or stream reaches with high-suspended sediment levels. Deposited sediment affects the reproductive success of salmonids. Sediment can coat eggs and embryos, and fill the interstitial spaces of the redd (nest for depositing eggs) so completely that the flow of water containing oxygen is impeded or stopped, resulting in mortality. Another problem occurs when sedimentation on the streambed produces a consolidated armor layer through which emerging sac fry cannot penetrate, resulting in entombment of the fry (Waters, 1995). Salmonids are particularly sensitive to sediment in spawning gravels. Therefore, increases in instream sediment deposition are undesirable and are avoided whenever possible.

In areas where the ROW crosses riparian zones, the cleared ROW has the potential to impact aquatic life. Riparian vegetation has many influences on the stream ecosystem. Riparian vegetation produces food for fish and other animals, and habitat for insects that supplement the diet of fish. Riparian vegetation also forms a protective canopy that helps maintain cool stream temperatures in summer and insulates the stream from heat loss in winter. Since the influence of riparian vegetation generally decreases as streams get larger, small streams are likely to experience more severe impacts than large streams as a result of riparian vegetation removal (Murphy and Meehan, 1991).

Many types of vegetation can often be left in place when the ROW is very selectively cleared in these riparian zones. Although most tall-growing tree species can not be allowed to mature to their full heights within the ROW proper, they can be retained for some time when conductor to ground clearance allows, which is often common in these low lying stream bottoms. To minimize disruption in these riparian buffer zones, individual trees can be felled as needed over time, which allows for the maximum retention of vegetation and provides an ample period to permit the establishment of new vegetation.

Vegetation management activities on overhead and underground 500-kV transmission corridors can temporarily or permanently disrupt wildlife by displacing animals from their habitat. Trees are utilized for nesting, perching, hunting, shelter, and food, providing habitat for birds, mammals, and insects. Tree-dwelling wildlife can be disturbed and/or displaced when trees are removed or pruned. Increased noise levels and vehicle traffic from vegetation control equipment and vehicles can temporarily disturb animals causing them to flee the area. Ground-nesting birds, amphibians, and reptiles are vulnerable to mortality from the physical disruption of soils and vegetation caused by vegetation control equipment.

### **3.4.2.6 Wildlife Displacement and Disturbance from Underground Lines**

Wildlife displacement and disturbance from construction, operation, and maintenance of an underground 500-kV transmission line would be similar to impacts from construction of an overhead 500-kV transmission line with the following exceptions.

---

Disturbance of some wildlife species would be short-term and direct due to trenching activities. Displacement of some wildlife species, dependent on underground habitat, would be permanent due to installation of the underground 500-kV transmission line and associated equipment.

Although riparian areas are typically avoided with the use of trenching methods, the loss of riparian habitat would be a long-term, direct impact of underground transmission line construction resulting in displacement of riparian dependent wildlife species. Some types of vegetation, as indicated in studies described in the overhead section, take years to recover; trees and large shrubs are not allowed to mature within the permanent ROW.

### **3.4.2.7 Disruption of Rare, Threatened, and Endangered Plant Species and Habitat from Overhead Lines**

Direct and indirect impacts to listed endangered and threatened wildlife species populations, or even their candidate species, are a major environmental concern when building a new overhead 500-kV transmission line. This is due to the official status given these species with low population numbers, and the general tendency for such listed species to be less resilient to habitat alterations than other more commonly found fauna. Even temporary disturbances can have adverse impacts. Breeding habitat is especially important because disruption during breeding season can reduce productivity for the entire year. Specific impacts are dependent on the species' habitat requirements and the exact location of transmission related facilities.

Other wildlife species of concern may be those that are rarely found, or are unique to the project vicinity, or are considered special status species. The impacts to these species that should be considered include the potential for substantial interference with the movement of native resident or migratory fish or wildlife species, or with established native resident or migratory wildlife corridors, or activities that impede the use of wildlife nursery sites.

Vegetation management changes to the ROW can potentially have significant impacts on wildlife species with home ranges that are limited to the ROW. Wildlife species with broader home ranges can either be temporarily displaced or experience minor impacts from the ROW vegetation management activities.

### **3.4.2.8 Disruption of Rare, Threatened, and Endangered Plant Species and Habitat from Underground Lines**

Impacts to rare, threatened, and endangered wildlife species and habitat from construction of an underground 500-kV transmission line would be similar to impacts from construction of an overhead 500-kV transmission line with the following exceptions.

Although riparian areas are typically avoided with the use of trenching methods, the loss of riparian vegetation would be a long-term, direct impact of underground transmission line construction resulting in displacement of riparian dependent wildlife species. Some types of vegetation, as indicated in studies described in the overhead section, take years to recover; trees and large shrubs are not allowed to mature within the permanent ROW.

The impacts of trenchless methods to rare, threatened, and endangered wildlife species would be low due to the lack of surface disturbance. Temporary disturbance may result from equipment and workers near the exit and entry pits, and permanent disturbance of existing vegetation would result from excavation of the pits and permanent access to these locations.

---

A frac-out event, as well as fluid leaks, may disrupt and/or destroy rare, threatened, and endangered wildlife species through the displacement of subsurface soils onto the land surface and result in soil contamination. Any required clean-up activities may also disrupt and/or destroy these special status wildlife species both within and outside the ROW.

### **3.4.2.9 Herbicide Toxicity – Overhead and Underground Lines**

Modern herbicides used for ROW vegetation management have been studied in considerable detail, enabling researchers to assess the impacts of herbicides, including the results of interactions of chemicals with biological systems. The key to safe and effective use of herbicides is the principle of dose response. As dose increases, so also does the effect. For every compound there is a dose below which no effect can be detected. Risk analysis allows different products to be compared to determine if expected exposure will result in toxic impacts (Norris et al., 1997).

Common herbicides examined in detail as part of the Environmental Impact Statement for Vegetation Management on Electric Utility ROW on the Allegheny National Forest (and used commonly throughout the U.S.) were found to have very low toxicity "with virtually no potential for reproductive or genetic effects" and were not found to cause cancer. This EIS pointed out that "every chemical, whatever its source, can cause toxic impacts at some dose; no truly non-toxic chemical exists". Safe use of these products is based on knowing the pattern of toxicity for each herbicide, as well as the doses at which toxicity occurs and the doses below which no effect takes place. While use of registered herbicides according to label requirements does not pose detrimental environmental consequences, misuse of these products may result in significant harm. Methodologies have been developed to monitor the off-target application of herbicides that could pose avoidable risks to water resources (Norris et al., 1997).

The most dramatic impacts of herbicides on non-target plants and animals often result from the habitat alterations they cause by killing the targeted weeds. For example, loss of invasive riparian plants can cause changes in water temperature and clarity that can potentially impact the entire aquatic community, and the physical structure of the system through bank erosion. Removing a shrubby understory can make a habitat unsuitable for certain bird species, and expose small mammals to predation.

### **3.4.3 Biological Resources Mitigation Techniques**

The following mitigation techniques can be used to minimize impacts on biological resources during construction, operation, and maintenance of an overhead or underground 500-kV transmission line. For vegetation management mitigation techniques see section 3.10.

1. Restrict all construction vehicle movement outside the ROW to pre-designated access, contractor-acquired access, or public roads.
2. In construction areas where recontouring is not required, leave the vegetation in place wherever possible and maintain the original contour to avoid excessive root damage and allow for resprouting. Limit disturbance to overland driving where feasible to minimize changes in the original contours.
3. Prior to construction, instruct all supervisory construction personnel on the protection of biological resources. The construction contract can address:
  - a. Federal, state and tribal laws regarding plants and wildlife, including collection and removal.
  - b. The importance of biological resources and the purpose and necessity of protecting them.

- 
- c. Methods for protecting sensitive resources, including instruction on wildlife policy to prohibit unauthorized off-road vehicle use in the project area, and to discourage wildlife harassment and littering.
  4. Adhere to Section 7 of the Endangered Species Act (1973) as specified by the U.S. Fish and Wildlife Service (USFS), Biological Opinion of the USFS, and other appropriate agencies.
  5. Delineate the boundaries of sensitive plant populations with clearly visible flagging or fencing based on surveys completed prior to construction. In the event any special-status plants require relocation, obtain permission from the appropriate agencies. If avoidance or relocation is not practical, the topsoil surrounding the plants can be salvaged, stored separately from the subsoil, and spread during the restoration process.
  6. Develop a noxious weed and invasive plant control plan in consultation with the appropriate agencies and local weed control districts to minimize the impacts of noxious weeds due to proposed project activities. The plan can address measures to minimize the spread of noxious weeds and invasive plants and control methods after construction.
  7. Train the contractor on methods for cleaning equipment, identification of problem plant species in the project area, and appropriate project procedures when an invasive or noxious weed is located. Supply the contractor with a list and pictures of noxious and invasive species that may exist in the project area.
  8. Promptly seed disturbed areas following completion of construction activities to reduce the potential for the spread and establishment of noxious weeds and invasive plants. Seeding of appropriate plant cover should occur as soon as possible following construction and during the optimal time period for establishment of desirable plant species.
  9. Apply herbicides for weed control by qualified personnel according to the label instructions. Orient spray units to minimize drift and chemical entry into streams. Use spray buffer strips along streams to reduce or eliminate the impacts of herbicide spraying on aquatic environments.
  10. Limit ground disturbance to what is necessary to safely and efficiently install the proposed facilities.
  11. Prepare a revegetation plan in consultation with the appropriate agencies. The plan can specify the disturbance types and their appropriate revegetation techniques to be applied for all proposed project work areas and access roads. Techniques could include reseeding native or other acceptable vegetation species with certified weed-free seed. The plan can include approved management and maintenance procedures for ongoing use of access roads and temporary work areas.
  12. Erosion and sediment control measures can be specified and meet the requirements of the Clean Water Act.
  13. Install barriers along travel ways bisecting the underground transmission line easement to minimize erosion potential and encourage vegetation regeneration. Barriers may include gates and post/pole fencing, in addition to the use of natural obstacles such as rocks, logs, planted native shrubs, and vegetation slash.



- 
14. Avoid sedimentation loading downstream and impacts on fisheries at specific stream crossings by scheduling trenching operations to occur through streams during dry or low flow periods.
  15. Modify or curtail construction activities during sensitive periods (e.g., nesting and breeding) for candidate, proposed threatened and endangered, or other sensitive animal species.

### **3.4.3.1 Avian Interactions**

Avian interactions would be largely limited to overhead 500-kV transmission structures. Typically, avian species utilize overhead transmission facilities for perching, hunting, roosting, and nesting purposes in areas where natural supports (e.g., trees) are uncommon. Birds landing on or colliding with transmission lines and associated support structures can result in outages and bird fatalities. Power line electrocutions and collisions are not the primary causes of bird mortality and population reductions. Habitat loss is the most significant cause of avian population declines worldwide. However, as discussed above, the creation of ROW can result in habitat loss for interior specialist species and overhead transmission installations can have direct impacts on bird populations. In turn, avian populations have direct impacts on transmission facilities. Many avian-transmission interactions result in power outages negatively impacting electric service reliability, as well as increasing costs associated with power delivery.

Avian interactions and 500-kV transmission impacts can be divided into the following general categories:

- Collisions
- Electrocutions
- Outages
- Habitat Enhancement

#### ***3.4.3.1.1 Collisions***

Avian collisions occur when flying birds are unable to avoid overhead transmission wires or structures and strike the facilities, typically resulting in injury or death. Collisions are more likely to occur in conditions of poor visibility or when birds are flushed by a disturbance. Some bird species are more prone to power line collisions depending upon their morphology, flocking habits, and flight behavior (Roig-Soles and Navaso-Lopez, 1997). Large, heavy, less maneuverable species such as cranes, herons, swans, and geese are more likely to collide with transmission lines. Transmission line placement can also have a large influence on collision potential. Transmission lines placed near avian concentration areas, such as large wetland complexes, or bisecting high use areas, such as roosting and feeding areas, can result in higher instances of collisions with transmission lines. In the case of a large-conductor, such as a 500-kV line, birds rarely collide with the conductors. Instead, birds will increase in altitude to avoid the large diameter conductors and collide with the smaller, overhead groundwire above. It is estimated that 174 million birds are killed every year by colliding with both distribution and transmission power lines (APLIC, 2006).

V-guyed structures are occasionally used for large transmission lines such as 500-kV. In these instances, the guy-wires supporting the V shaped structure would increase the likelihood of avian collision with the transmission line supporting structures. Numerous studies have noted avian collisions with guy-wires on radio antennas (Avery and Beason, 2000; Crawford and Engstrom, 2001; Manville, 2001).

---

### ***3.4.3.1.2 Electrocutions***

Thousands of birds are electrocuted every year by distribution and transmission facilities, including, raptors, crows, ravens, vultures, herons, owls, pelicans, and pigeons (APLIC, 2006). Avian electrocutions are far more common on distribution lines (i.e., 60 to 70-kV) than on transmission lines because the distance between wire conductors or distances between wires and their support structures are greater on transmission facilities than on distribution facilities. Avian electrocutions occur when a bird either touches two conductors at the same time (phase-to-phase) or when it simultaneously comes in contact with an energized conductor and the transmission support structure causing electric current to go through the bird body to ground (phase-to-ground). A bird's propensity to be electrocuted is also driven by its size (i.e., wingspan), hunting habits, nesting habits, and weather conditions. Wet feathers are known to be more conductive than dry feathers, thus making birds more vulnerable to electrocutions during rain (APLIC, 2006).

### ***3.4.3.1.3 Outages***

Bird collisions and electrocutions do not necessarily result in bird-caused outages. Additional bird-related outage causes include:

- Nesting materials causing phase-to-phase or phase-to-ground conditions.
- Prey remains come in contact with energized conductors or equipment.
- Damage caused by pecking or acid degradation from accumulation of fecal contamination reducing component life expectancy.
- Long streams of excrement (streamers) discharged from large birds causing flashovers.
- Large flocks perching on lines and taking off at the same time, causing oscillation in the line and flashovers.

Avian-related outages detrimentally impact system reliability, increase revenue loss due to outages, and increase costs associated with power restoration and equipment repair. Many utilities have increased their efforts (and costs) to implement bird management programs as bird populations continue to use transmission line corridors for habitat.

Avian-related outages would be rare on a 500-kV transmission line. 500-kV transmission lines are typically large, with enough distance between conductors to avoid coming into contact with prey remains, streamers, or fecal contamination. The typical distance between conductors is likely too large for flashovers to occur from oscillation after large flocks perch and take off from a line. Spacing of the conductors on a 500-kV transmission line is also typically too large for nesting material to cause a phase to phase or phase to ground connection; however contact of nesting material with energized phases can cause the nest to catch on fire and cause wildfires.

### ***3.4.3.1.4 Habitat Enhancement***

Numerous scientific studies conclude that overhead 500-kV transmission line corridors can provide valuable habitat for edge specialist avian populations. The wire and border zones provide for the foraging and nesting of edge specialist species. Wire zones are those habitats which fall directly within the maintained ROW. Boarder zones are those habitats where the maintained ROW stops and the previously existing habitat resumes. Boarder zones are also referred to as edges. Initial ROW clearance in a forest habitat will cause an initial decrease in the local bird population, but as early successional plant and shrub habitats develop, a net increase in bird populations typically occurs as new species move in (Bramble et

---

al., 1987). In addition, ongoing maintenance activities do not detrimentally impact bird populations or bird species diversity if timed outside of the nesting season (Bramble et al., 1986).

Bird species that nest in brushy or grassy vegetation created by the wire and boarder zones are particularly prevalent on transmission ROW. On the State Game Lands 33 Research and Demonstration Project in central Pennsylvania, the abundance of birds along the ROW was about seven times higher than in the adjacent forest and nearly four times as many birds were observed in the shrubby border zones than in the wire zones (Yahner et al., 2002).

Transmission structures also provide suitable habitat for raptors and owls that employ perch-and-dive hunting techniques. Transmission towers and poles provide a perching support with widespread views of the surrounding hunting area. One study demonstrated that raptor density significantly increased following construction of a 245 kV overhead transmission line in Colorado (Stahlecker, 1978). However, this may be to the detriment of prey populations below overhead transmission lines. Numerous studies have noted the deleterious impacts of overhead transmission lines on greater sage grouse (*Centrocercus urophasianus*), a candidate species for the Federal Endangered Species Act (Graul 1980, Braun 1998, Aldridge and Brigham 2002, Braun et al. 2002, Knock et al. 2003).

A telemetry study conducted in California from 1998 – 2000 found that transmission lines may have negative impacts on sage grouse lek attendance at distances of over 12 miles. The data also showed that the mean survival of adult greater sage grouse increased as the distance from a transmission line increased. However, it was concluded that the data did not indicate that these impacts may be limiting to the population for leks more than three miles from the transmission line (Armentrout and Hall 2005).

Many bird species also use transmission structures as nesting sites. For example, 133 pair of raptors and ravens were successfully nesting on transmission towers within 10 years of construction of a 500-kV transmission line in the Snake River Valley of Idaho and Oregon (Steenhof et al., 1993). In general, there is greater clearance between conductors on transmission spans, and support structures allow sufficient space and support for birds to nest without causing significant problems for electrical operations (APLIC, 2006). But, as previously discussed, nests that are located above insulators or conductors may cause equipment failures and outages due to nest materials, prey remains, or fecal contamination. Also, birds utilizing transmission towers or poles are more likely to be electrocuted or collide with conductors.

However, this too may have a deleterious effect on threatened and endangered species. Corvids (Corvids are the family of birds that includes ravens and crows) are known to be one of the major nest predators of greater sage grouse (Watters et al, 2002), and a major source of mortality to federally threatened desert tortoise (*Gopherus agassizii*; Boarman, 2003).

### 3.4.3.2 Avian Interaction Mitigation Techniques

The following mitigation techniques can be implemented to minimize impacts on bird populations resulting from the construction, operations, and maintenance activities of overhead 500-kV transmission lines:

- Develop and implement a comprehensive Avian Protection Plan (APP) or at least portions of an APP. An APP's purpose is to minimize utility impacts to bird populations while, at the same time, facilitate safe and reliable electric service. The following 13 components of an APP can be considered (APLIC, 2006; Liguori and Burrell, 2008):
  - **Corporate Policy:** Develop a statement and policy committing a utility to balance the protection of avian species with providing safe, reliable, and cost effective service. The

---

statement typically includes provisions for avian interaction and mortality reporting, efforts toward avian-friendly design and construction, and regulatory compliance.

- **Training:** Training can be provided to all leadership, management, supervision, engineers, design, and field personnel on avian interaction issues and applicable utility policies including, but not limited to regulatory compliance, construction and design standards, nest management, and incident reporting. Ongoing supplemental training can be provided as needed.
- **Permit Compliance:** Develop and communicate utility processes under which employees secure necessary permits related to avian interaction issues.
- **Construction and Design Standards:** Utilities can consider avian interactions during the design and construction of new transmission facilities as well as during ongoing operations and maintenance efforts. Bird-safe construction and retrofitting options include, but are not limited to installing nesting platforms, anti-perch or perch-friendly devices, and/or requiring sufficient clearance between phases or phases and grounds.
- **Nest Management:** Develop, implement, and train employees on nest management procedures including, but not limited to nest siting, nest removal, and how to obtain applicable nest relocation or removal permits.
- **Avian Reporting System:** Develop an avian interaction reporting system. Utilize a database to track trends associated with avian interactions in order to identify concern areas with high incident frequencies.
- **Risk Assessment Methodology:** Focus efforts cost effectively by identifying and prioritizing areas and structures that pose the greatest risk for avian mortalities. Conduct a risk assessment by evaluating available data related to avian electrocutions, nesting areas, established migratory bird flyways, prey populations, perch availability, and other factors contributing to avian-utility interactions.
- **Mortality Reduction Measures:** Develop a mortality risk reduction plan that identifies and prioritizes options for reducing avian electrocutions and outages (high priority monitoring areas, lines to be retrofitted, etc.) and set a task completion schedule.
- **Avian Enhancement Options:** Develop an avian enhancement plan that incorporates initiatives to enhance avian populations and habitat through use of nesting platforms, managing habitat to attract migratory birds or prey for raptors, or working collaboratively with organizations and/or agencies that are involved in such efforts.
- **Quality Control:** Develop provisions or policies designed to ensure quality control and continuous improvement related to the utility's avian interaction management efforts.
- **Public Awareness:** Document and communicate avian conservation efforts to agencies and the public. Communication efforts can facilitate program buy-in and a positive public image.
- **Key Resources for Troubleshooting:** Identify resources and personnel who are capable of being avian interaction experts. For example, environmental specialists can assist operations and maintenance personnel with identifying retrofit opportunities designed to maximize bird protection and system reliability.

- 
- **Installation of bird flight diverters:** Identify preferred bird flight diverter to be installed on lines in problem areas such as wetlands, river crossings, and landscape features which may attract birds.

### **3.5 Geological and Soil Resources**

Constructing, operating, and maintaining a 500-kV transmission line without disrupting, changing or destroying geological and soil resources can be a challenge, although some areas are more sensitive than others due to the type of resource. Erosive and compaction prone soils are particularly susceptible to negative impacts from construction, operation, and maintenance of a 500-kV transmission line. Impacts on geological and soil resources from ROW construction of an overhead 500-kV transmission line can result in the following:

- Soil erosion and/or compaction
- Reclamation constraints due to soil type
- Disturbance or access limitations to mineral resources
- Disturbance to unique geological features
- Disruption of soil profile

#### **3.5.1 Soil Erosion and/or Compaction – Overhead Lines**

Soils impacted by an overhead 500-kV transmission line are primarily associated with structure installation, substation and access road installation, material storage and staging areas, ROW vegetation clearing, and maintenance vehicle access. These disturbances, although temporary (e.g. construction and any reclamation), may result in an increase in soil erosion and compaction levels. Actual erosion depends on factors at a particular site such as weather events, soil properties, slope, and adjacent vegetation or lack thereof. Vegetation creates a canopy covering the soil, and root systems bind soils reducing runoff and erosion. Erosion rates can increase significantly when vegetation is removed.

Potential soil erosion hazards vary depending on the use, conditions, and textures of the soils. The properties of soil which influence erosion by rainfall and runoff are ones that affect the infiltration capacity of a soil, and those which affect the resistance of a soil to detachment and being carried away by falling or flowing water. Additionally, soils on steeper slopes would be more susceptible to erosion due to the impacts of increased surface flow (runoff) on slopes where there is little time for water to infiltrate before runoff occurs. Soils containing high percentages of fine-grained sand and silt and having low densities (loose, uncompacted), are generally the most erodible. As the clay and organic matter content of these soils increases, the potential for erosion decreases. Clays act as a binder to soil particles, thus reducing the potential for erosion.

Potential long term impacts may result in the following: a decrease in productivity due to erosion and/or compaction; difficulty in reclaiming unstable soils; and irreparable damage to low productivity soils. Wheeled vehicles and heavier vehicles result in higher impacts, with the potential for longer term impacts.

Soil erosion can occur along the ROW primarily at individual construction sites. The potential for erosion is most likely to occur during the construction phases of a project when clearing, excavation, and fill operations are most intense. Until vegetation is re-established, borrow pits, ROW access roads, stream crossings, staging areas, and structure construction sites are especially vulnerable to erosion. Road maintenance activities may also contribute to soil erosion.

---

Grading for new project facilities (e.g., substations and access roads) would disturb large areas and the upper soil surface and protective vegetation will be loosened or removed. Planned areas of grading and disturbed surfaces might become susceptible to wind and water erosion, which would result in soil loss and potential sedimentation in nearby water resources.

Transmission construction activities can impact the water quality downstream from the affected disturbance area. The disturbance comes from clearing, grading, excavations, drilling, or blasting to construct support structures, and associated facilities. Other causes are heavy equipment traffic near staging areas, access roads, and at other critical work locations along the ROW. Water quality may be affected by sedimentation from nearby or upstream construction activities.

All soils crossed by underground or overhead 500-kV transmission lines can be impacted by vegetation management activities. Disturbance or loss of vegetation can result in increased soil erosion. Vegetation control equipment and vehicles can increase soil compaction. Moderate or severe soil compaction affects soil productivity potential. The extent of compaction depends on soil moisture content and the physical characteristics of a particular soil type. Compaction tends to be less severe when soils are dry and more severe when soils are moist to wet.

### **3.5.2 Soil Erosion and/or Compaction – Underground Lines**

Extensive erosion control measures may be required (e.g. silt fencing, fiber rolls, sedimentation trap/basin, temporary swales or dikes, instream sediment trapping devices, etc.) when trenching methods are used because a trench is dug the entire line length and the ROW is totally cleared. In areas with hilly terrain and erosive soils, significant erosion and sedimentation impacts could arise from trenching methods. Underground construction does not have the flexibility to avoid unstable areas encountered by the line route; thus the potential for impacts to unstable areas may be substantial.

Use of trenchless methods, such as directional drilling, would result in no impact to surface soils except where the entry and exit pits reside. There may be temporary as well as permanent impacts at the pit sites due to excavation of the pits and disturbance from workers and equipment. Soils would be displaced from drilling and insertion of the transmission line. These displaced subsurface soils would most likely be removed from the site if not usable at the entry and exit pit areas.

### **3.5.3 Reclamation Constraints Due to Soil Type – Overhead and Underground Lines**

Soils developed on Cretaceous shales and intrusive and lacustrine sediments are more difficult to reclaim and revegetate due to their chemical composition and mechanical weathering products. Cretaceous shales and lacustrine sediments often produce highly saline soils, and intrusive rocks generally weather to granular sands with little nutrient availability. Soils with low water holding capacity are also more prone to impacts from compaction.

Use of trenchless methods would reduce reclamation constraints due to soil type because there would be no surface soil disturbance except at the entry and exit pit locations.

### **3.5.4 Disturbance or Access Limitations to Mineral Resources – Overhead and Underground Lines**

A new overhead transmission line may disturb, limit or prevent access to mineral resources such as mines, quarries, or oil or gas fields due to installation of the ROW, structures, access roads, and facilities.

---

### **3.5.5 Disturbance to Unique Geological Features – Overhead Lines**

ROW construction activities associated with the construction of an overhead 500-kV transmission line have the potential to disturb unique geological features of a particular area. The transmission line can disrupt the visual quality of the geological feature or there may be direct disturbance if construction of an access road or installation of a structure is adjacent or directly in line with the particular feature.

### **3.5.6 Disturbance to Unique Geological Features – Underground Lines**

Impacts to unique geological features from construction of an underground 500-kV transmission line using trenching methods would be significant because the feature would be irreplaceable or irreparably damaged due to installation of the trench and equipment.

Trenchless methods could reduce or eliminate impacts to unique geological features if the transmission line could be installed under the feature without disturbance.

### **3.5.7 Disruption of Soil Profile – Overhead Lines**

Vegetation management activities can affect soils and geological resources by altering soil nutrient levels. Impacts to soil resources can occur from inversion of the soil profile, loss of structure, and alteration of soil chemistry. For example, removing brush cover can, over time, reduce the amount of carbon in the soil, especially if revegetation does not occur. Removing nitrogen-fixing plants can also reduce soil nitrogen levels and impact plant productivity. Removing vegetation can also create erosion impacts. Erosion allows increased water to leach soluble nutrients and transport organic matter and nutrients offsite, thereby reducing soil productivity potential.

Accidental liquid spills (e.g., herbicides, oil, and hydraulic fluids) can cause soil contamination. The potential impacts on soil contamination can be localized and limited in their extent and magnitude, if appropriate best management practices and other mitigation measures are implemented in a timely fashion.

An herbicide's persistence in soils is often described by its half-life (also known as the DT50). The half-life is the time it takes for half of the herbicide applied to the soil to dissipate. The half-life gives only a rough estimate of the persistence of an herbicide, since the half-life of a particular herbicide can vary significantly depending on soil characteristics, weather (especially temperature and soil moisture), and the vegetation at the site. Dissipation rates often change with time (Parker and Doxtader, 1983). For example, McCall et al. (1981) found that the rate of dissipation increased until approximately 20% of the applied herbicide remained, and then declined. Nonetheless, half-life values do provide a means of comparing the relative persistence of herbicides.

The distribution of an herbicide in the soil is determined primarily by the amount, type, and surface area of clays and organic matter in the soil; the amount and quality of soil moisture; and soil temperature and soil pH (Helling et al., 1971). Most natural soils have pH values between five and eight. Rainfall and the amount of leaching that has occurred strongly influence these values. In wet areas and/or coarse soils, cations (positively charged ions) can be leached out, leaving the soil acidic. In arid and semi-arid regions, soils retain cations and are more alkaline. Acidic soils can also be found in wetlands where organic acids lower the soil's pH.

---

### **3.5.8 Disruption of Soil Profile – Underground Lines**

Impacts to soil resources from trenching methods can occur from inversion of the soil profile, loss of structure, and mixing of layers as the trench is backfilled. These impacts may also occur at the entry and exit pit locations when trenchless methods are used. This may result in increased erosion and compaction and less productive soil for vegetation. Underground 500-kV transmission lines using trenching methods require the importation of select thermal backfill in many instances. The sources of these materials can be located many miles from the project area. Borrow sites for these materials result in significant disturbances to the soil profiles of the borrow area and can contribute to land use and erosion impacts at the borrow sites without proper reclamation and stabilization techniques, such as reseeding, fiber rolls, biofilter bags, temporary storm drain systems, etc.

Impacts from vegetation management of the ROW would be similar to the description under section 3.5.7.

### **3.5.9 Geological and Soil Resources Mitigation Techniques**

The following mitigation techniques may be used to reduce impacts from construction, operation, and maintenance of overhead and underground 500-kV transmission lines. For vegetation management mitigation techniques see section 3.10.

1. Restrict all construction vehicle movement outside the ROW to pre-designated access, contractor-acquired access, or public roads.
2. In construction areas where re-contouring is not required, leave the vegetation in place wherever possible and maintain the original contour to avoid excessive root damage and allow for re-sprouting. Limit disturbance to overland driving where feasible to minimize changes in the original contours.
3. Implement suitable precautionary measures following identification of soils with high erosion potential and/or soluble salt content so suitable precautionary measures can be properly planned and implemented.
4. Erosion and sediment control measures must be specified and meet the requirements of the Clean Water Act.
5. Limit ground disturbance to that necessary to safely and efficiently install the proposed facilities. Avoid soil-disturbing actions during periods of heavy rain or wet soils.
6. Maintain long-term adequate ground cover and soil structural characteristics by:
  - a. Stockpiling topsoil removed during construction activities and salvage and reapply during restoration.
  - b. Retain plant debris to be left on-site as much as practical to serve as mulch.
  - c. Reclaim disturbed erodible soils as quickly as possible, or apply protective covers where necessary.
7. Install barriers along travel ways, bisecting the underground transmission line easement to minimize erosion potential and encourage vegetation regeneration. The barriers can lower soil impacts by discouraging motorized vehicle access and travel. Barriers may include gates and post/pole fencing in addition to the use of natural obstacles such as rocks, logs, planted native shrubs, and vegetation slash.



- 
8. Use existing public roads and conduct all construction activities in a manner that minimizes soil disturbance to the extent possible. Use dust-control measures during road construction in sensitive areas, as required. Leave all existing roads in a condition equal to or better than their condition prior to construction of the transmission line.
  9. Conduct a field verification of all landslide-prone areas and make appropriate adjustments as needed.
  10. Prepare a geotechnical report prior to construction to address risks to structures and roads due to potential seismicity and liquefaction.
  11. To facilitate revegetation and minimize soil compaction, target only severely compacted areas for disking (ripping), with the depth extending to subsoils if necessary.
  12. To minimize erosion and sedimentation transport, temporary control measures (e.g., silt fences, straw bale fences, terracing, water bars, matting, settling ponds, or other erosion control techniques) can be installed prior to and during construction in graded or disturbed areas, steep slopes that exceed 30%, and in other sensitive areas.
  13. Monitor stabilization methods and revegetation success for a minimum of two growing seasons or until 75-80% revegetation is achieved as approved by the appropriate agency or landowner.
  14. Promote soil restoration in sloped disturbance areas with placement of the appropriate amount and type of erosion control material.
  15. Complete a thorough survey of the proposed project ROW to avoid any unique geological features.
  16. Limit construction and vehicle travel during periods of excessive soil wetness to prevent rutting and compaction.
  17. Use rubber-tired work vehicles instead of tracked vehicles to reduce environmental impacts on soil resources.

### **3.6 Water Resources**

Constructing, operating, and maintaining a 500-kV transmission line without disrupting, changing, or destroying water resources can be a challenge, although some areas are more sensitive than others due to the type of resource. Wetlands are particularly susceptible to negative impacts from construction, operation, and maintenance of a 500-kV transmission line. Impacts to water resources from construction, operation, and maintenance of an overhead or underground 500-kV transmission line can result in the following:

- Disturbance to surface water flows and floodplains
- Disturbance to wetlands
- Disturbance to groundwater
- Water quality degradation

---

### **3.6.1 Disturbance to Surface Water Flows and Floodplains – Overhead Lines**

Physical changes to surface water resources from the installation of an overhead 500-kV transmission line are directly linked with the runoff from the land surface. An increase in surface water runoff entering a stream can produce the following impacts: an increase in downstream flow; an increase in channel width or depth; erosion of the stream's bed and/or banks; and build up of sediment in a stream.

During construction, some streams or waterways may need to be crossed by access roads. Such direct impacts on the stream environment can cause erosion of the streambed and banks causing increased sediment loads and downstream aggradations. The need to selectively clear some riparian vegetation may affect surface water flows and floodplains.

Construction near surface water has the potential to alter localized drainage patterns of the area. A permanently altered drainage pattern can temporarily increase erosion and sedimentation until the banks are stabilized, eliminate the previous riparian corridor while eliminating non-riparian vegetation in the new corridor, harm wildlife, or damage existing land uses. If drainage patterns are altered, this can change floodwater flows and associated floodplains. Encroachment into a floodplain or watercourse by a permanent aboveground project feature, such as the tower leg of a support structure, can result in flood diversions, or erosion (localized scouring).

Additionally, streams or waterways may need to be diverted during construction. In addition to impacts on aquatic wildlife, riparian vegetation, and recreation activities, the diversion of streams or waterways during construction of an overhead 500-kV transmission line can affect surface water flows and floodplains.

Vegetation management can affect surface water (ponds, lakes, wetlands, streams, and rivers) and groundwater (wells and aquifers) resources when vegetation is cut or removed. Vegetation control activities can impact water resources by increasing surface runoff, causing erosion, facilitating sedimentation, reducing shading, increasing water temperatures, and inhibiting nutrients from entering the water by limiting plant debris buildup.

### **3.6.2 Disturbance to Surface Water Flows and Floodplains – Underground Lines**

Impacts to surface water flows and floodplains from construction of an underground 500-kV transmission line would be similar to impacts from construction of an overhead 500-kV transmission line with the following exceptions.

Disturbance from trenching activities could be substantial because of the soil, vegetation, and hydrological disturbance required for installation of the trench and transmission line, particularly if crossing waterways or water bodies as they would be disrupted, altered, or destroyed by the trenching activities.

Trenchless methods are often used to cross waterways or water bodies in the transmission line ROW because this method does not disrupt or destroy the resource; although, it opens the potential for impacts from a frac-out event. A frac-out event under a waterway or water body would introduce sediment to the water resource and if the discharge of subsurface soil is large enough it may disrupt surface water flows.

### **3.6.3 Disturbance to Wetlands – Overhead Lines**

ROW preparation (clearing of trees within the ROW and access roads) and facility construction (substations, support structure foundations and/or erection work zones) of an overhead transmission line

---

can temporarily or permanently alter wetland systems. Because wetland systems are a unique combination of hydrology, soils, and vegetation, disrupting one of these conditions may irreversibly damage the wetland ecosystems processes.

Certain functions and values of wetlands can be permanently adversely affected during the construction of overhead transmission lines, substations, and access roads, such as the conversion of a forested wetland to an herbaceous wetland in the permanently maintained utility line ROW. As discussed under the vegetation resource section, Thibodeau and Nickerson (1986) reported on the impacts of utility ROW construction and maintenance on the vegetation of a forested wetland and found that except for differences in size and maturity, the vegetation recovered in two years from nearly total destruction caused by construction. Maintenance of the ROW, that included the periodic removal of tall-growing species, led to the formation of a plant association different from the one occurring naturally, but as diverse and species rich.

In another study (also discussed under the vegetation resource section), Nickerson et al. (1989) reported on the long term impacts of construction of an overhead utility ROW through a cattail marsh, forested swamp, and shrub/bog wetland, and discovered that both the cattail marsh and forested swamp recovered within a few years, while the plant composition of the shrub/bog wetland plant was still lower after ten years.

If a wetland system cannot be spanned or avoided by an overhead transmission line, the potential for irreversible damage to the wetland system is substantial.

#### **3.6.4 Disturbance to Wetlands – Underground Lines**

Impacts to wetlands from construction of an underground 500-kV transmission line would be similar to impacts from construction of an overhead 500-kV transmission line with the following exceptions.

Disturbance from trenching activities could be substantial because of the soil, vegetation, and hydrological disturbance required for installation of the trench and transmission line, particularly if crossing wetlands as they would be disrupted, altered, or destroyed by the trenching activities.

Trenchless methods are often used to cross wetlands in the transmission line ROW because this method does not disrupt or destroy the resource; although, it opens the potential for impacts from a frac-out event. A frac-out event under a wetland would introduce sediment and if the discharge of subsurface soil is large enough it may permanently impact the wetland by destroying or altering the vegetation, wetland hydrology, and hydric soils.

#### **3.6.5 Disturbance to Groundwater – Overhead Lines**

In general, groundwater is often found near the surface in the vicinity of substantial surface water bodies. In other areas (e.g., mountainous regions), groundwater can occur at great depths. When located at a shallow depth (i.e., on the order of tens of feet), groundwater is more susceptible to adverse impacts associated with construction, maintenance, and surface spills; and changes in recharge (DOE and DOI, 2007).

Excavations for overhead 500-kV transmission line foundations which encounter such groundwater close to the surface can temporarily or permanently alter groundwater flows by changing the underground channels and/or pools that exist. This has the potential of affecting existing domestic wells.

---

Dewatering the transmission support structure foundation site is often necessary in areas with high water tables (tens of feet from the surface). The main dewatering techniques include: barriers, sump and ditches, wellpoint systems, deep-well systems, and cutoffs. These techniques can impact the existing water table, potentially increase soil erosion, increase surface water downslope, and potentially impact adjacent land use, vegetation, and wildlife depending on where, in what quantity, and the duration of the water diversion activity.

Soil compaction from access roads and compacted backfills at structure sites can alter ground surface percolation rates, which can subsequently affect groundwater recharge to underlying aquifers.

### **3.6.6 Disturbance to Groundwater – Underground Lines**

Impacts to groundwater from construction of an underground 500-kV transmission line would be similar to impacts from construction of an overhead 500-kV transmission line with the following exceptions.

If groundwater or storm water inflow is encountered during trenching, dewatering and disposal of the water is required.

Trenchless methods may impact groundwater resources due to a frac-out event. Subsurface soils from a frac-out event may flow into groundwater resources and alter the nature, flow, and quality of the groundwater by introducing sediments.

### **3.6.7 Water Quality Degradation – Overhead Lines**

The quality of surface water in regards to 500-kV transmission line construction activities is primarily influenced by the presence of sediment, microbes, pesticides, and nutrients. Surface water quality is also affected by the amount of solar radiation received and the shade-producing vegetation in the riparian area that, in turn, affects water temperature, as well as other water quality factors such as flow rates, total suspended solids, total dissolved solids, turbidity, and changes in dissolved oxygen, salinity, and acidity. Construction near surface water has the potential to directly impact the quality of these water resources through erosion or discharge of materials.

The period of highest potential impact from overhead transmission projects is during and immediately following construction from the ROW work sites, staging areas, or access roads. Construction in ephemeral drainages, when waterless, could deposit sediment on the dry streambed, which could then be available for transport to the stream system when flows resume.

Maintenance vehicles and road maintenance can disturb water resources, resulting in compaction and/or erosion impacts that can directly or indirectly affect water quality. Performing road maintenance can result in severe rutting and gulying during wet periods, resulting in large amounts of sediment into the watershed. Ground disturbance from road blading, particularly where the road is immediately adjacent to streams, constitutes the greatest risk from increased sediment production. Other activities such as culvert and ditch maintenance can also increase sediment delivery to streams. However, lack of road maintenance can result in serious impacts to streams as well. This includes washouts, as well as increased risk of vehicle accidents, which may introduce potential toxic fuels to streams. This is especially critical when roads are adjacent to streams with sensitive species.

ROW clearing requirements can affect riparian vegetation ability to positively influence water quality characteristics. Water quality of surface waters can also be directly impacted through the accidental release of pollutants such as fuel, lubricants, or antifreeze during construction.

---

Using herbicides for vegetation control that are not labeled for aquatic use can also potentially affect water resources. Water resources can be contaminated by overspray, or when herbicides drift, volatilize, leach through soils to groundwater, or are carried in surface or subsurface runoff. Amounts of leaching and runoff are largely dependent on total rainfall the first few days after an application. Total losses to runoff generally do not exceed five to ten percent of the total applied, even following heavy rains (Taylor and Glotfelty, 1988). High soil adsorption capacity, low rates of application and low rainfall reduce total runoff and contamination of local waterways (Bovey et al., 1978).

### **3.6.8 Water Quality Degradation – Underground Lines**

Impacts to water quality from construction of an underground 500-kV transmission line would be the similar to impacts from construction of an overhead 500-kV transmission line with the following exceptions.

Water quality degradation from trenching activities could be substantial because of the soil, vegetation, and hydrological disturbance required for installation of the trench and transmission line. Erosion and sedimentation of waterways and water bodies may temporarily alter the water quality.

Trenchless methods are often used to cross waterways or water bodies in the transmission line ROW because this method does not disrupt or destroy the resource; although, it opens the potential for impacts from a frac-out event. A frac-out event under any water resource would introduce sediment, which may temporarily impact water quality. If the discharge of subsurface soil is large enough and flows directly, or even indirectly, into a water resource, it may impact water quality over an extended period of time.

A fluid leak from the underground transmission line may temporarily or permanently impact water quality if the contaminants in the fluid spread into nearby water resources. Clean-up activities from a fluid leak may further impact water quality by spreading the contaminants around.

### **3.6.9 Water Resources Mitigation Techniques**

The following mitigation techniques can be used to minimize impacts on water resources during construction, operation, and maintenance of an overhead or underground transmission line. For vegetation management mitigation techniques see section 3.10.

1. Restrict all construction vehicle movement outside the ROW to pre-designated access, contractor-acquired access, or public roads.
2. Prior to construction, instruct all supervisory construction personnel on the protection of water resources. The construction contract can address:
  - a. Federal, state and tribal laws regarding water resources.
  - b. The importance of water resources and the purpose and necessity of protecting them.
3. Build roads at right angles to the streams and use existing public roads to the extent possible. Install culverts where needed. Conduct construction activities in a manner that minimizes disturbance to vegetation, drainage channels, and stream banks.
4. Develop a crossing for vehicles and construction equipment and create an appropriate undisturbed vegetation buffer. If the soil within the vegetation buffer is disturbed prior to construction, install sediment barriers across the transmission line ROW.

- 
5. Install culverts or temporary work bridges across all streams that are flowing at the time of construction to provide access to the work areas on both sides of the streams. This will minimize stream bank degradation, erosion, and sediment into the waterway.
  6. Have all construction vehicles and equipment traffic travel around wetland areas when possible.
  7. Locate staging areas for stream and wetland crossings a minimum of 50 feet away from the stream bank or edge of designated wetland areas. Install the appropriate sediment traps and/or filter barriers as needed. Limit the size of the staging area to the minimum amount needed to construct the crossings. All construction equipment must be kept out of flowing stream channels except when absolutely necessary to construct crossings. Clean, washed gravel can be used in stream crossing construction activities to reduce solid suspension in adjacent surface waters.
  8. Store hazardous materials, chemicals, fuels, and lubricating oils a minimum of 500 feet from stream banks, wetlands, or municipal watershed areas. Refuel equipment or vehicles no closer than 300 feet from a stream bank or wetland. Monitor onsite vehicles and equipment for leaks, and conduct regular preventative maintenance to reduce the chance of petroleum leaks. Develop a spill prevention plan to address containment and cleanup of spills affecting surface waters.
  9. Remove trench topsoil from the streambed for segregated stockpiling in adjacent upland areas. When possible, place trench spoil at least 10 feet away from stream banks at all stream crossings. When this cannot be accomplished, locate the spoil pile in the stream in such a manner as to prevent undue flow restrictions. Prevent the flow of spoil off the construction ROW. Set aside streamside woody shrubs with attached root wads during construction for reestablishment along stream banks following construction.
  10. Backfill the transmission line in such a manner as to prevent additional disturbance of previously undisturbed soil in streambeds or wetland areas.
  11. Salvage wetland topsoil containing wetland plant parts and seeds to an approximate depth of 12 inches and stockpile adjacent to the trench. Stockpile excavated subsoil separately from the salvaged topsoil.
  12. Restore streambeds, banks, and wetlands as near to pre-construction contours as possible and reseed. Place boulders in original locations and set to the original soil line. Facilitate channel recovery by retaining and re-establishing woody shrubs after construction is complete. If existing shrubs cannot be salvaged, obtain native shrubs from nearby nurseries and plant if required by permits or the restoration techniques specific to the project. Ground matting (excelsior blankets) can be installed on slopes of stream banks to accelerate vegetation stabilization.
  13. Backfill the trench with previously excavated subsoils and place the salvaged topsoil on top of the trench and disturbed areas within the construction zone.
  14. Allow no vehicle traffic on the ROW except as needed to maintain the ROW, and for transmission line maintenance and repair except in cases where the access road is jointly used by underlying landowners or others.
  15. Pre-approve the use of water for construction activities such as dust suppression.
  16. Apply herbicides for weed control and other vegetation management activities following the established tenets of Integrated Vegetation Management according to the label instructions and by

---

qualified personnel under the supervision of a certified pesticide applicator. Orient spray units to avoid streams and drift to minimize chemical entry into streams. Use spray buffer strips along streams to reduce or eliminate the impacts of herbicide spraying on aquatic environments.

17. Avoid sedimentation loading downstream and impacts to fisheries at specific stream crossings by scheduling trenching operations to occur through streams during dry or low flow periods.
18. Support structures can be located, if feasible, to avoid active drainage channels, and to minimize the potential for damage by flash flooding. Diversion dikes or other structural enhancements are required to divert runoff around the base or leg(s) of structures if the location in an active channel cannot be avoided. In floodplains, appropriate design of support structure footing foundations, such as raised foundations and/or enclosing flood control dikes, will be used to prevent scour and/or inundation by a 100-year flood.

### **3.7 Cultural Resources**

Constructing, operating, and maintaining a 500-kV transmission line without disrupting, changing or destroying cultural resources can be a challenge, although some areas are more sensitive than others due to the type of resource. Unknown and undocumented cultural resources are particularly susceptible to negative impacts from construction, operation, and maintenance of a 500-kV transmission line. Impacts to cultural resources from construction, operation, and maintenance of an overhead and underground 500-kV transmission line can result in the following:

- Ground disturbance
- Visual and audible intrusions
- Vandalism
- Increased visitation

#### **3.7.1 Ground Disturbance – Overhead and Underground Lines**

Cultural resources are non-renewable resources. Any disturbance to the vertical and horizontal distribution of artifacts and other pertinent cultural material is permanent and irreparable. Even temporary or short-term activities associated with transmission line construction that can crush or destroy surface or subsurface artifacts, or evidence of past activities, can cause permanent damage to these vulnerable resources. Therefore, cultural resources are very sensitive to any construction activities that result in ground disturbance such as earthmoving for support structure foundations and substations, cut and fill for building the access road system, ROW preparation, or underground trenching activities.

Operation and maintenance activities, including vegetation management activities, can damage, destroy, alter eligibility to NRHP, or expose cultural or historical sites, and harm plants with traditional cultural value on sites of traditional cultural value. Heavy equipment or vehicles utilized for maintenance activities can also disturb surface artifacts as a result of soil and erosion impacts.

#### **3.7.2 Visual and Audible Intrusions – Overhead Lines**

While the extrinsic value of cultural resources is not affected by the visibility of a transmission structure, some cultural resources and Native American sacred sites may be very sensitive to such visual intrusions in the otherwise natural landscape. Overhead 500-kV transmission lines result in the creation of a ROW, with support structures and overhead conductors that are plainly visible, often for some distances. During the construction phase, this visual imposition can be even greater as the presence and movement of large-

---

scale machinery, equipment, and the number of vehicles can also contribute to adverse impacts on those cultural resources with a landscape component. Maintenance activities can also cause visual intrusions on cultural resources.

Audible intrusions may also negatively impact some cultural resources and Native American sacred sites where noises outside the “norm” for the area may disrupt activities such as ceremonies, rituals, or the experience of viewing or enjoying the resource. Audible intrusions may come from construction and maintenance machinery, equipment, and vehicles, and noise from corona discharge when the lines are wet if within a few yards of the ROW.

### **3.7.3 Visual and Audible Intrusions – Underground Lines**

The visual quality of cultural resources may be disrupted by the underground ROW which must be kept clear of tall vegetation and structures and provide unlimited vehicle access. The presence and use of maintenance vehicles may also cause visual intrusions on cultural resources.

Audible intrusions may come from construction and maintenance machinery, equipment, and vehicles, but there would be no noise from the underground line itself.

### **3.7.4 Vandalism – Overhead and Underground Lines**

Improved access to a previously remote area may result in increased levels of vandalism to cultural resources. Any increase in the presence of humans in an uncontrolled and unmonitored environment containing significant cultural resources increases the potential for adverse impacts caused by looting (unauthorized collection of artifacts), vandalism, and inadvertent destruction to unrecognized resources (DOE and DOI, 2007). Cultural resources that are visually obvious (e.g., rock art, standing buildings) or become known to many people (e.g., burial sites), or attractive to vandals (e.g., large prehistoric archaeological sites, 19th century trash dumps) are more sensitive than smaller, less visible or well-known resources.

### **3.7.5 Increased Visitation – Overhead and Underground Lines**

Improved access to cultural resources or increased awareness of their presence due to construction of the transmission line may lead to increased visitation. Increased visitation may lead to unintended damage to cultural resources from trampling due to foot or vehicle traffic, damage from touching the resources, or other visitor activities. Increased visitation may also lead to a greater appreciation, knowledge, and support of cultural resources values.

### **3.7.6 Cultural Resources Mitigation Techniques**

The following mitigation techniques can be used to minimize impacts on cultural resources during construction, operation, and maintenance of an overhead or underground transmission line. For vegetation management mitigation techniques see section 3.10.

1. Protection of Historic Properties (36 CFR 800) should be consulted as it describes the steps for identification for historic properties and the mitigation process should any be identified.
2. Prior to transmission line construction and any other surface disturbing activities conduct an inventory of cultural resources within the project area. The nature and extent of this inventory is based upon project engineering details and construction specifications such as types of structures and ROW widths. All cultural resource work must be carried out by qualified professionals. As



---

part of the inventory, field surveys must be conducted within the ROW to identify cultural resources that can be affected by support structure construction, access road installation, and all other sites affected by transmission line construction and operation. Field surveys need also be conducted along newly proposed access roads, new staging yards, and any other projected impact areas outside of the ROW.

3. Upon completion of the inventory, a treatment plan to mitigate identified impacts on cultural resources must be prepared. Avoidance, recordation, and data recovery can be used as mitigation alternatives. Mitigation may require the relocation of the line, support structure site placement, access road routes, movement of other ancillary or temporary facilities or work areas, where relocation can avoid or reduce damage to cultural resource values. When necessary to relocate the line and any other components of the transmission facility as a method of mitigation, it is recommended that the proposed new locations be inventoried for cultural resources and provide inventory results prior to construction. Any mitigation deemed necessary can be completed prior to undertaking any surface disturbing activities (for the federal government, necessary mitigation must be completed prior to undertaking any surface disturbing activities). If avoidance of specific cultural resources is not feasible, additional treatments must be carried out in consultation with experts in cultural resources.
4. Restrict all construction vehicle movement outside the ROW to pre-designated access, contractor-acquired access, or public roads.
5. Prior to construction, instruct all supervisory construction personnel on the protection of cultural resources. The construction contract can address:
  - a. Federal, state and tribal laws regarding antiquities and fossils, including collection and removal.
  - b. The importance of cultural resources and the purpose and necessity of protecting them.
  - c. Methods for protecting sensitive cultural resources.
6. In the event that potentially historic or cultural resources are discovered during construction, halt all work within 300 feet of the find. Immediately implement the following measures:
  - a. Erect flagging to prohibit potentially destructive activities from occurring in a given area.
  - b. Utilize an archeologist to make a preliminary assessment of the newly discovered resource.
  - c. Notify the appropriate landowner, agencies, and State Historic Preservation Office (SHPO) if the archeologist determines that the discovery represents a potential new site or an undocumented feature of a documented site.
  - d. Do not resume construction in the identified area until cleared by the archeologist (all land) and the agencies' authorized officer.
7. Applicable to federal and Indian lands: Pursuant to 43 CFR 10.4(g), the permit holder must notify the authorized officer by telephone (along with written confirmation) immediately upon the discovery of human remains, funerary items, or sacred objects of cultural patrimony. Further, pursuant to 43 CFR 10.4(c) and (d), activities must stop in the vicinity of the discovery and it must be protected for 30 days or until the authorized officer notifies with approval to proceed.
8. Specific agencies may require a cultural resource monitor to be present during construction in areas the agency determines to be culturally sensitive.

---

## 3.8 Visual Resources

### 3.8.1 Visual Resource – Overhead Lines

Constructing, operating, and maintaining a 500-kV transmission line without disrupting, changing or destroying visual resources can be a challenge, although some areas are more sensitive than others due to the type of resource. Highly scenic and/or sensitive areas are particularly susceptible to negative impacts from construction, operation, and maintenance of a 500-kV transmission line.

Direct, long-term impacts are expected in areas where overhead 500-kV transmission lines cross areas of outstanding scenic quality or visual appeal; where lines are in the vicinity of cities, towns, communities, and other population concentrations; and where ROW are near or cross sensitive recreation and transportation viewpoints. Hence a visual environmental impact assessment is a combination of the areas scenic quality coupled with viewer sensitivity (value of the visual landscape to the viewing public). Visual impacts associated with the construction, operation, and maintenance of an overhead 500-kV transmission line could include potential impacts to:

- Views from residents and communities – rural residences and communities dispersed throughout the study area.
- Views from parks, recreation and preservation areas – potential views from existing and proposed facilities and other developed sites including national monuments, state parks, national natural landmarks, proposed wilderness areas, and other public and private recreation areas.
- Views from sensitive transportation corridors – backcountry byways, scenic byways, and other sensitive travel routes.
- Views from sensitive cultural sites – National Historic Landmarks and other National Register sites or districts or historic property potentially eligible to NRHP or TCPs.
- Visual resource management – compatibility with BLM and USFS visual management designations.
- Scenic quality – impacts affecting the inherent aesthetic value of the landscape.

Visual impacts would result from the visibility of the line from sensitive viewpoints and from the contrast of the line with the inherent aesthetic value of the landscape. Potential impacts to views are greatest when there are high sensitivity levels coupled with close views and highly contrasting project elements.

Visual impacts resulting from construction, operation, and maintenance of an overhead 500-kV transmission line can be both short and long term. Short-term visual impacts can result from views of construction activities including the presence and storage of materials, construction workers, equipment, and landform contrasts as a result of any ROW vegetation clearing, as well as from access road grading and foundation excavation. Long-term impacts can result from permanent visual contrasts of the structures and conductors in the ROW, landform contrast, and vegetation contrast.

Structure contrast examines the compatibility of transmission facilities with the existing landscape. The long-term impact of structure contrast would be greatest where there are no other structures (e.g. buildings, existing utilities) in the landscape. One method for determining structure contrast is the presence or absence of existing parallel transmission lines. For example, a new 500-kV steel lattice tower located next to an existing 500-kV steel lattice tower would create a weak contrast, or little structure change to the existing landscape, whereas a new 500-kV steel lattice tower located next to an existing 161-kV wood H-frame structure and transmission line would create a moderate contrast, because the 500-kV line and structure are larger and bulkier than the 161-kV line and structure. The difference in

structure contrast level is due to both the difference in heights and the substantial difference in appearance between the structures.

The long-term impact of landform contrast is created by alteration of landform patterns, exposure of soil, erosion scars, slumping, and other disturbances due to the project that are uncharacteristic of the natural landscape. Landform contrast is largely determined by the degree and duration of ground disturbance due to access roads and construction. Measures of landform contrast include: 1) Access/ground disturbance level (extent of new road construction or improvements to existing roads); and 2) Soil contrast (based upon soil erosion potential).

Levels of access/ground disturbance could be defined as follows:

- Level 1 – Use existing improved roads. Area previously disturbed. Roads generally are in good condition but may require small improvements at stream crossings, steep slope area, and other locations. New ground disturbance would be minimal.
- Level 2 – Use roads that require improvement. Area previously disturbed. Existing two-track or narrow unimproved roads would require improvement to make roads serviceable (e.g. mowing, grading) for construction. Low ground disturbance.
- Level 3 – Construct road in flat terrain (0 to 8 percent). Low to moderate ground disturbance for new access road construction.
- Level 4 – Construct road in sloping terrain (8 to 15 percent). Moderate ground disturbance for new access road construction.
- Level 5 – Construct road in steep terrain (15 to 30 percent). Moderate to high ground disturbance for new access road construction.
- Level 6 – Construct road in very steep terrain (over 30 percent). High to very high ground disturbance for new access road construction.

The level of access/ground disturbance in combination with the soil contrast results in the total landform contrast. The following table is an example of this combination, which can be used to determine the level of landform contrast for a project.

SOIL CONTRAST	6	5	4	3	2	1
High Erosion Potential	S	S	S	M	W	W
Moderate Erosion Potential	S	S	M	W	W	W
Low Erosion Potential	M	M	W	W	W	W

S = Strong Contrast; M = Moderate Contrast; W = Weak Contrast

The third long-term impact which can result from permanent visual contrast is vegetation contrast. The presence of the overhead transmission line requires a permanent ROW, which includes clearing of all trees and tall shrubs, if present. This condition must be maintained to allow access and maintenance of the line. Vegetation contrast is determined by the diversity and complexity of vegetation types and patterns. Diversity is a major criterion in determining the inherent capability of the landscape to absorb visual changes. The vegetation contrast in relation to vegetation types and patterns is discussed in the following paragraphs.

Changes to overstory vegetation types (coniferous and deciduous trees) would result in a strong contrast rating, particularly with linear transmission lines that require trees to be removed from the entire width of

---

the transmission line corridor for fire safety or other conditions. The result would be an exposed and unnatural corridor clearing in the canopy layer.

Changes to shrub vegetation types would result in a strong to weak contrast rating. Shrubs removed during initial construction of a transmission line corridor will be allowed to grow back into the ROW and around the tower footings, and may fill in to their original density except along maintenance roads.

Changes to grassland and agriculture vegetation types would result in a broad range of contrast levels due to differences in potential vegetation recoverability and compatibility with the transmission line. Grasses tend to be shorter and less dense in content. Additionally, many grass types have light brown, tan, or gray colors that blend effectively with the soils from which the grasses are growing. While a road through grasslands would be visually obvious initially, grasses on either side of the road cut have the potential to blend with exposed soils. Grasses are also most easily reseeded and will typically grow back into the disturbed ROW more quickly. Impacts to grass vegetation tend to be short-term and less visually dominant.

Changes to sparsely vegetated types would result in moderate to weak contrasts. Low density of vegetation and exposed soils would allow a road cut to be less obvious and blend into the surroundings. However, vegetation may be slow to grow back in disturbed areas.

Bare lands and many urban areas lack natural vegetation and would therefore result in weak vegetation contrasts.

High voltage electric transmission structures (lattice towers or poles), where visible, can potentially create negative visual impacts in almost all landscapes. The support structures and conductors, as well as the insulators, can collectively create substantial visual impacts. A transmission line's visual presence can last from the time it is built throughout the duration of the line usefulness.

Support structures for the 500-kV lines would be a steel lattice tower, or, in some cases, a single steel pole. These structures can be as tall as 200 feet with crossarms as much as 100 feet wide, although typically crossarms are much shorter. Taller structures are generally needed for special situations (e.g., spanning valley or river crossings). Lattice towers have an open framework, but are overall much wider than poles visually. Poles present a single (or sometimes double, i.e., two poles are required), but more dense upright structure, but overall their width is much smaller than that of a lattice tower. Special steel lattice angle or turning towers may be used to bear the extra weight and tension of conductors where a turn occurs in the line. Such angle towers utilize stronger, thicker, steel poles than are used for typical tangent steel lattice towers, and are more substantial than typical towers. Dead-end structures are likewise heavier and similar in appearance due to their need to withstand a collapse of all structures on one side

Under certain conditions, lattice towers tend to blend better than steel poles into the background when viewed from a distance against mountains or vegetation. With their slender beams and open structure, they allow the forms, lines, colors, and textures of the background landscape to show through. Steel poles may create less contrast with the natural environment in foreground views when seen against the sky (i.e., skylined) compared to the "industrial" structural look of lattice towers, which can be visually overbearing at short distances (DOE and DOI, 2007).

Given the relative openness of some nearly treeless landscapes, the viewshed may be quite extensive and the availability of viewing opportunities from travel routes, recreational use areas, and nearby residential and commercial areas can be very high. In such open landscapes and under favorable viewing conditions, support structures and conductors might be visible for many miles, especially if skylined. In areas that

---

are heavily forested with evergreens and deciduous species, such long views might be restricted and the views of the line may be much more limited in distance. However, in areas of predominately deciduous trees, the viewing analysis conducted to determine the visual impact of the transmission facility must be conducted at a time of year when no leaves are present on the trees to get a more accurate portrayal of the line's visibility.

Tower structures, insulators, and particularly conductors are sometimes subject to specular reflection. That is, at times they may be capable of reflecting light like a mirror. These "mirror images" of light can cause bright reflections of sunlight to appear under certain optical conditions when the sun directly illuminates the reflective surface. These bright reflections can extend the visibility of transmission facilities for several miles.

Indirect, long-term impacts to visual resources from construction, operation, and maintenance of an overhead 500-kV transmission line may include reduced property values or loss or change in property development or land use potential and/or existing uses. While there are no studies indicating that transmission lines reduce property values due to the visibility of the line, in highly scenic and/or sensitive areas, this may occur. Development, land use and potential use may change due to visibility of the large 500-kV line and the associated ROW.

Vegetation management activities can change the visual quality of the landscape and local viewsheds impacted by transmission line ROWs. The following factors influence the impact of vegetation control activities on visual resources:

- Land use (agriculture, forest, rural, urban, transportation)
- Landscape setting and color (desert, mountainous, wetland, grassland, forest)
- Season
- Vegetation cover

Removing tall-growing vegetation can create a sudden, but temporary impact on local visual resources. Long-term visual impacts can result when the removed vegetation acts as a screen for unsightly views. For example, removing a row of trees along the ROW may reveal an open-pit mine and tailings pond otherwise hidden when recreationists use the area.

Herbicide treatment can temporarily affect visual quality by turning the treated vegetation brown. The brown vegetation can be left standing, making the effect more noticeable, but the effect usually lasts less than one year. Mechanical or manual cutting can create brown, dead vegetation as well, but it is typically not left standing after treatment and may be less visible.

### **3.8.2 Visual Resources – Underground Lines**

Direct, long-term impacts are expected in areas where ROW corridors cross areas of outstanding scenic quality or visual integrity; where ROW corridors are in the vicinity of cities, towns, communities, and other population concentrations; and where ROW corridors are near or cross sensitive recreation and transportation viewpoints. Visual impacts associated with the construction of an underground 500-kV project include potential impacts to the same views as described under the visual resource – overhead section above.

Visual impacts resulting from construction of an underground 500-kV transmission line can be both short and long term. Short-term visual impacts can result from views of construction activities including the presence and storage of materials, construction workers, equipment, and landform contrasts from grading

---

and trench excavation. These short-term visual impacts include the ROW, access roads, and staging areas.

Long-term impacts result from permanent visual contrasts of the ROW corridor. The presence of the underground transmission line requires a permanent ROW, which includes clearing of all trees and tall shrubs, if present. This condition must be maintained for the life of the project to allow access and maintenance of the line.

Underground transmission lines placed in existing developed corridors (e.g., road, utility) are not likely to detract from the existing view area. For example, a ROW through a forest has noticeable differences in vegetation for the first few years. With each successive year, however, the contrast is weaker, and within a few years is not noticeable to the casual viewer. There can be impacts due to loss of roadside vegetation, potentially including notable old trees. Vegetation loss impacts are greatest along more rural or residential streets than roadways in commercial areas.

The most recurring benefit regarding underground 500-kV transmission lines is the aesthetic appeal to a vista without the interruption of utility lines. One aspect of aesthetics that is often overlooked is the overall impact it has on the quality of life. It is often the quality of places where people seek to relax, recharge and revitalize their lives. The state of Hawaii recognizes this by requiring an evaluation on the proximity and visibility of above ground high-voltage transmission systems to high density population areas, conservation and other valuable natural resource areas, public recreation areas, areas of special importance to the tourist industry, and other industries particularly dependent on Hawaii's natural beauty (Martin, 1999).

The environmental impacts to visual resources as a result of trenchless methods would be minimal due to the lack of surface ground disturbance from the trenchless method. Visual resources impacts would result from the installation and required permanent access to the entry and exit pits as all vegetation would be removed from these sites. A frac-out event may also produce visual resource impacts especially if it occurs within a sensitive viewshed as the displaced soil could be very visually intrusive in the landscape.

### **3.8.3 Visual Resources Mitigation Techniques**

The following mitigation techniques can be used to minimize impacts on visual resources during construction, operation, and maintenance of an overhead and/or underground transmission lines. For vegetation management mitigation techniques see section 3.10.

1. When building a new line next to an existing one, match existing and new line support structure types, spacings, heights, and conductor heights to the extent practical.
2. Use non-specular conductors to reduce glare and visual contrast.
3. When crossing highways, rivers and trails, place support structures at the maximum feasible distance from these features to reduce the visual impact. The ROW should also cross these linear features at right angles whenever possible to minimize the viewing area and duration.
4. Place support structures to avoid features and/or to allow conductors to clearly span the feature (within limits of standard tower design) to minimize the amount of sensitive feature disturbed and/or reduce visual contrast (e.g., avoiding skyline situations through placement of tower to one side of a ridge or adjusting tower location to avoid highly visible locations and utilize screening of nearby landforms) (California Public Utilities Commission and DOI, 2006).

- 
5. In deserts and semiarid land areas where views of land scars from sensitive public viewing locations are unavoidable, disturbed soils can be treated with Eonite or something similar to reduce the visual contrast created by the lighter-colored disturbed soils and the darker vegetated surroundings.
  6. In forested locales, leave as much vegetation as possible along roads, providing roadside screens and reducing impacts to views down the ROW.
  7. In forested environments, lower support structure height to the surrounding vegetation canopy heights.
  8. To reduce visual contrast in areas where forested vegetation is removed for access, tower pads or conductor clearance, the clearing edges will be feathered to give a natural appearance.
  9. In general, site the new ROW to take advantage of both topography and vegetation as screening devices to restrict views of transmission facilities from visually sensitive areas.
  10. Where screening topography and vegetation are absent, use natural-looking earthwork berms and vegetative or architectural screening to minimize visual impacts. Where possible, vegetative screening can be particularly effective along roadways (DOE and DOI, 2007).
  11. Use appropriate colored structures, with coatings or paints having little or no reflectivity where possible.
  12. Poles may reduce visual impact more effectively than lattice towers in the near view areas, whereas lattice towers may be more visually suitable for more distant.
  13. Reduce visual contrast and siltation in construction areas (e.g., marshalling yards, structure sites, or spur roads from existing access roads) where ground disturbance is substantial, by re-contouring and restoring the site. Re-contour the land to the original contours as much as possible. Method of restoration normally consist of loosening the soil surface, reseeding, installing cross drains for erosion control, placing water bars in the road, and filling ditches.
  14. In construction areas where re-contouring is not required, vegetation will be left in place wherever possible and original contour will be maintained to avoid excessive root damage and allow for re-sprouting. Disturbance would be limited to overland driving where feasible to minimize changes in the original contours.
  15. Restrict all vehicle movement outside the ROW to pre-designated access, contractor-acquired access or public roads where possible.
  16. No paint or permanent discoloring agents would be applied to rocks or vegetation to indicate limits of survey or construction activity.
  17. To minimize ground disturbance and/or reduce scarring (visual contrast) of the landscape, the alignment of any new access roads or cross-country routes will follow the landform contours in designated areas where practicable, providing that such alignment does not impact resource values additionally.

---

## **3.9 Public Health and Safety**

### **3.9.1 *Electric and Magnetic Fields (EMF) – Overhead and Underground Lines***

An EMF exists wherever electricity is produced or used. EMFs are invisible lines of force that surround any electrical appliance or wire that is conducting electricity. Electric fields are created by voltage; the higher the voltage, the stronger the field. The farther away from the source of the electric field, the weaker it becomes. These fields are easily blocked by walls, trees, and even clothes and skin. Electric fields are measured in kilovolts/meter (kV/m). Magnetic fields only exist when an appliance or transmission line is turned on; the higher the current, the greater the magnetic field. As with electric fields, the strength of the magnetic field dissipates dramatically the further away from the source. However, unlike electric fields that are easily blocked, magnetic fields can pass through walls, clothes, and other barriers. Magnetic fields are measured in milliGauss (mG).

All transmission lines produce EMFs. The fields are the strongest directly under the lines and drop dramatically with distance to the sides of the line. Electric fields from power lines are relatively stable because the voltage does not change. Magnetic fields fluctuate as current changes in response to increasing and decreasing loads.

Undergrounding can eliminate electric fields, but since magnetic fields are hard to block, burying power lines won't keep the magnetic fields from passing through the ground. Additionally, underground lines can produce higher levels of magnetic fields directly above them at ground level because these lines are located closer to the ground surface than overhead lines. The strength of the magnetic field from underground lines falls away more quickly than from overhead lines.

EMF has been studied for more than 30 years by government and scientific institutions all over the world. In 1992, The U.S. Congress directed the National Institute of Environmental Health Sciences to direct the EMF Research and Public Information Dissemination Program. The goal of this program was to provide evidence to clarify potential health risks from EMF exposure. To date, the evidence suggesting that EMF exposures cause health risks is weak.

There are no standards established for safe levels of exposure to EMF. Some organizations have set advisory limits as a precautionary measure. The International Commission on Non-Ionizing Radiation Protection has established a continuous magnetic field exposure limit of 833 mG and a continuous electric field exposure limit of 4.2 kV/m for the general public. The American Council of Governmental Industrial Hygienists has set a Threshold Limit Value for occupational exposure to magnetic and electric fields at 60 Hz (60 cycles per second). Electricity in North America produces EMF at 60 Hz. The Threshold Limit Value for magnetic fields at 60 Hz is 10,000 mG and 25,000 kV/m for electric fields.



### **3.10 Vegetation Management Mitigation Techniques**

The following mitigation techniques can be used to minimize impacts on all of the above environmental resources for vegetation management activities conducted in the ROW for an overhead and underground 500-kV transmission line.

#### **3.10.1 Manual and Mechanical**

1. If soil disturbance from vegetation control activity is significant on slopes with potential erosion impacts, re-seed the area with desirable native vegetation or take other erosion control measures as necessary.
2. Leave debris from vegetation cutting, mowing, brush cutting, or weed eating on site, as appropriate, to provide wildlife habitat and nutrients to the ecosystem.
3. Avoid or minimize the amount of vegetation debris falling into or being left in any surface water sources.
4. Avoid using heavy ground-disturbing equipment to clear vegetation on surfaces with slopes greater than 20%.
5. Utilize heavy equipment or trucks only when the ground is sufficiently dry to avoid excessive rutting and potential erosion impacts.
6. Use the tilling technique only in highly disturbed soils.
7. Maintain all equipment, machinery, and vehicles in good working condition to avoid oil or fuel spills. Avoid repairing or washing equipment near surface water sources.

#### **3.10.2 Chemical**

1. Strive to select herbicides that are effective against the plant; not likely to drift, leach into groundwater, or wash into streams; are non-toxic to people and other organisms; that are not persistent in the environment; and which are easy to apply.
2. Consider the following site conditions before application: accessibility, proximity to open water, depth to groundwater, the presence of rare species and other sensitive plants or animals, and the site's sensitivity to trampling that can occur when the herbicide is being applied.
3. Orient spray units to avoid direct spray and indirect drift into surface water resources, unless using aquatic herbicides. Use spray buffer strips along surface water resources to reduce or eliminate the effects of herbicide spraying on aquatic environments.
4. Develop safety protocols for storing, mixing, transporting, handling spills, and disposing of unused herbicides and containers before obtaining herbicides.
5. Follow all federal, state, and local regulations regarding herbicide use. Read and follow product labels. It is a violation of federal law to use an herbicide in a manner inconsistent with its label.
6. Require herbicide applicators to have all certificates and licenses required by the state and/or county.

- 
7. Follow all county and state rules and regulations regarding pesticide spills. Develop a spill response protocol. Contact the local fire department or county hazardous materials office for large spills (generally over 100 gallons).
  8. When using herbicides, it is critical (and, in some cases, required by law) to keep records of all plants/areas treated, amounts and types of herbicide used, and dates of application. This information can be used to evaluate the project's success, improve methodology, identify mistakes, and protect the environment.
  9. Mix a dye with the herbicide so applicators can see which plants are treated and whether the applicators inadvertently sprayed any herbicide on themselves or their equipment.
  10. Apply the herbicide at the appropriate time of year for the herbicide's mode of action, the physiology of the target species, and the site conditions. Check the label or consult with the distributor for the best application time under the conditions at the site.

---

## 4.0 SUMMARY

Constructing and maintaining overhead and underground 500-kV transmission lines can result in both positive and negative environmental impacts. The particular site and situation will dictate the degree and number of both negative and positive impacts.

The primary negative impacts associated with land use for both overhead and underground transmission lines include:

- Temporary and permanent impacts associated with construction and maintenance activities such as dust, noise, traffic, and access issues;
- Potential temporary disruption of existing utility lines;
- A permanent change/loss in existing land use such as farming, timber production, recreation use, and buildings; and
- Temporary disruption of services such as emergency response, travel, and access.

Additional negative impacts on land use from underground 500-kV transmission lines include:

- The ROW may be incompatible with some uses such as farming, forestry, mines, gravel pits, etc.;
- Some uses may be permanently disrupted such as farming and forestry; and
- Future development or activities may be impaired.

The primary negative impacts on biological, geological, water, and cultural resources for both overhead and underground 500-kV transmission lines are a result of temporary and potentially permanent disruption or destruction of the existing resource, as well as changes that may take place to the resources over time due to the initial disruption and subsequent maintenance activities of the ROW (i.e. habitat fragmentation, habitat loss, introduction of native species, vegetation management, soil compaction, vandalism).

Additional negative impacts on biological, geological, water and cultural resources from underground 500-kV transmission lines include:

- Increased potential for invasive species to establish within the ROW;
- Increased potential for wildlife displacement due to disturbance from trenching activities;
- Lower vegetation diversity within the ROW;
- Increased potential for impacts from ground disturbance from trenching activities;
- Potential for impacts from increased soil temperatures; and
- Potential disruption and/or destruction from a frac-out event (trenchless techniques) or fluid leak.

The primary negative impacts on visual resources from overhead and underground 500-kV transmission lines include:

- Construction activities such as equipment stockpiling, presence of construction equipment and vehicles, and installation activities; and
- The presence and maintenance of the ROW.

The positive environmental impacts of an overhead versus an underground 500-kV transmission line include:

- 
- Greater variety of compatible land uses within the ROW;
  - Potentially greater variety of wildlife and vegetation species within the ROW;
  - Lower potential for introduction of invasive species; and
  - Reduced potential for disturbance to geological, soil, and water resources, and some cultural resources because of the ability to span sensitive features.

The positive environmental impacts of an underground versus an overhead 500-kV transmission line include:

- Lower impact to residential land uses;
- No avian interactions with the line; and
- The aesthetic appeal to a vista without the interruption of utility lines, benefiting visual resources and potentially cultural resources.

A positive environmental effect of both overhead and underground would be that construction and maintenance of the ROW may benefit certain plant and animal species.

In general, the negative environmental impacts of constructing and maintaining an underground transmission line outnumber the negative impacts of constructing and maintaining an overhead transmission line, even though the ROW width is narrower for underground transmission lines. There may be projects, particularly in urban settings, where the positive impacts outweigh the negative impacts of an underground versus an overhead transmission line. Each project must be evaluated based on the particular site, associated environmental resources, project goals, and desired outcome. Application of the described mitigation techniques may also eliminate or reduce the negative impacts to acceptable levels.

#### **4.1 Relative Environmental Impact Severity of Overhead versus Underground 500-kV Transmission Lines**

There is an extensive amount of information related to the environmental impacts of overhead and underground transmission line construction, operation, and maintenance. This section has two purposes: 1) to summarize a large volume of material and 2) to provide a concise comparison of potential environmental impacts associated with underground and overhead transmission lines. This section is to simply summarize the options against each other, rather than against existing conditions.

Many variables are not taken into consideration. For example, overhead structure selection (lattice tower versus single pole), and construction mitigation methods are not taken into consideration.

The following tables summarize the environmental impacts associated with overhead and underground transmission lines as described in earlier sections of this report. Potentially beneficial and detrimental environmental impacts are categorized and subjectively assigned descriptions (Similar, Higher, or Lower) comparing relative severity of the environmental impacts between overhead and underground 500-kV transmission line construction (Table 2) and maintenance activities (Table 3).

**TABLE 2 CONSTRUCTION OF 500-KV TRANSMISSION LINES**

Categorization of Potential Environmental Issues that are similar, higher, or lower in impact between Overhead and Underground Transmission Construction.

<b>ENVIRONMENTAL ISSUES</b>	<b>UNDERGROUND NEGATIVE IMPACTS</b>	<b>OVERHEAD NEGATIVE IMPACTS</b>
<b>LAND USE</b>		
Agriculture	Higher	Lower
Forest	Higher	Lower
Residential	Lower	Higher
Commercial	Similar	Similar
Parks, Recreation, Preserves	Higher	Lower
Public Facilities	Lower	Higher
Industrial	Higher	Lower
Transportation and Access	Similar	Similar
<b>Biological Resources</b>		
Disrupting Existing Vegetation	Higher	Lower
Changing Habitat / Vegetation Composition	Similar	Similar
Habitat / Species Fragmentation	Similar	Similar
Habitat Loss / Reduced Species Abundance	Similar	Similar
Disruption to Rare, Threatened, Endangered Species	Similar	Similar
Introduction of Invasive Species	Higher	Lower
Wildlife Displacement	Higher	Lower
<b>Geological and Soil Resources</b>		
	Higher	Lower
<b>Water Resources</b>		
Surface Flow and Flood Plains	Higher	Lower
Wetlands	Higher	Lower
Groundwater	Higher	Lower
Water Quality Degradation	Higher	Lower
<b>Cultural Resources</b>		
Ground	Higher	Lower
Visual	Lower	Higher
Vandalism	Similar	Similar
Visual Resources	Lower	Higher

**TABLE 3 MAINTENANCE AND OPERATIONS OF 500-KV TRANSMISSION LINES**  
 Categorization of Potential Environmental Issues that are similar, higher, or lower in impact between Overhead and Underground Transmission Construction.

ENVIRONMENTAL ISSUES	UNDERGROUND NEGATIVE IMPACTS	OVERHEAD NEGATIVE IMPACTS
<b>Avian Interactions</b>		
Collisions	Lower	Higher
Electrocutions	Lower	Higher
Habitat Enhancement	Higher	Lower
<b>Soil Temperatures</b>	Higher	Lower
<b>Soil Contamination</b>	Higher	Lower
<b>Soil Compaction</b>	Higher	Lower
<b>Soil Erosion</b>	Higher	Lower
<b>Vegetation Maintenance Frequency / Intensity</b>	Similar	Similar
<b>Plant Community Diversity and Composition</b>	Higher	Lower

---

## 5.0 REFERENCES

- Albrecht S., R. Hinkle and E. Nathanson. 2000. Habitat fragmentation and biodiversity issues. Topical Report. Gas Research Institute. Des Plaines, IL: 2000. 00/00117.
- Aldridge, C.L. and R.M. Brigham. 2002. Sage-Grouse Nesting and Brood Habitat in Southern Canada. *Journal of Wildlife Management* 66(2): 433-444.
- Andren, H. 1994. Effects of habitat fragmentation on birds and mammals in landscapes with different proportions of suitable habitat: A review. *Oikos*. 71 (3): 355-366.
- Ariaratnam, S.T., Lueke, J.S., Allouche, E.N. 1999. Utilization of trenchless construction methods by Canadian municipalities. *J. of Const. Engineering and Mgmt.* March/April 1999. pp. 76-86.
- Avery, M.L., and R.C. Beason. 2000. Avian mortality at short (< 120 m) communication towers. Pilot Study Research Protocol to the Communication Tower Working Group. 7 pp (manuscript).
- Avian Power Line Interaction Committee (APLIC). 2006. *Suggested Practices for Avian Protection on Power Lines: The State of the Art in 2006*. Edison Electric Institute, APLIC, and the California Energy Commission. Washington, D.C. and Sacramento, CA.
- Baker, W. L. and R. L. Knight. 2000. Roads and Forest Fragmentation in the Southern Rocky Mountains. In *Forest Fragmentation in the Southern Rocky Mountains*. R. L. Knight, F. W. Smith, S. W. Buskirk, W. H. Romme, and W. L. Baker (eds.) University Press of Colorado. Boulder, CO.
- Bennett, A.F. 1991. Roads, Roadsides and Wildlife Conservation: a Review. In *Nature Conservation 2: The Role of Corridors*. D. A. Saunders and R. J. Hobbs (eds.) Surrey, Beatty and Sons. Victoria, Australia.
- Boarman, W.I. 2003. Managing a subsidized predator population: reducing common raven predation on desert tortoises. *Environmental Management*. 32:205-217.
- Bovey, R. W., C. Richardson, E. Burnett, M. G. Merkle, and R. E. Meyer. 1978. Loss of spray and pelleted picloram in surface runoff water. *Journal Environmental Quality*. 7(2): 178-180.
- Bramble, W.C. and W.R. Byrnes. 1983. Thirty years of research on development of plant cover on an electric transmission right-of-way. *Journal of Arboriculture* 9: 67-74.
- Bramble, W.C., W.R. Byrnes, and M.D. Schuler. 1986. Effects of special right-of-way maintenance on an avian population. *Journal of Arboriculture* 12(9): 219-226.
- Bramble, W. C., W.R. Byrnes, and R.J. Hutnik. 1987. Management and Environmental Impacts of Electric Power Transmission Rights-of-Way. *Environmental Consequences of Energy Production: Problems and Prospects*. Majumdar, S. K., Brenner, F.J., and Miller, E.W. (eds.). The Pennsylvania Academy of Science.

- Braun, C.E. 1998. Sage-Grouse Declines in Western North America: What Are the Problems? Proceedings of the Western Association of State Fish and Wildlife Agencies 78: 139-156.
- Braun, C.E., O.O. Oedekoven, and C.L. Aldridge. 2002. Oil and Gas Development in Western North America: Effects on Sagebrush Steppe Avifauna with Particular Emphasis on Sage Grouse. Transactions North American Wildlife and Natural Resources Conference 67: 337–349.
- Bridges, J.M., Barger, M., Chevance, N., Anderson, T., Holt, J., Jones, R., Nelson, E. 1997. Environmental impacts associated with routine transmission line maintenance. p. 19-23 *In* J. Williams, J. W. Goodrich-Mahoney, J. R. Wisniewski, J. Wisniewski (eds.) Proceedings of the 6<sup>th</sup> International Symposium on Environmental Concerns in Rights-of-Way Management, February 24-26, 1997, New Orleans, Louisiana.
- Bureau of Land Management (BLM). 1986a. Manual H-8410-1 – Visual Resource Inventory. BLM. Internet Website: <http://www.blm.gov/nstc/VRM/8410.html>.
- California Public Utilities Commission, U.S. Department of the Interior, Bureau of Land Management. 2006. Final Environmental Impact Report / Environmental Impact Statement Southern California Edison's Devers–Palo Verde 500 kV No. 2 Project (Application No. A.05-04-015). October 2006. Internet Website: <http://www.cpuc.ca.gov/environment/info/aspen/dpv2/toc-feir.htm>
- Chung, T.H., Abraham, D.M., Gokhale, S.B. 2004. Decision Support System for Microtunneling Application. *J. of Const Engineering and Mgmt.* Nov/Dec 2004. 835-843.
- Crawford, R.L. and R.T. Engstrom. 2001. Characteristics of avian mortality at a north Florida television tower: a 29-year study. *Journal Field Ornithology* 72(3): 380-388.
- Crooks, Kevin R. 2002. Relative Sensitivities of Mammalian Carnivores to Habitat Fragmentation. *Conservation Biology*. 16(2): 488-502.
- Dawson, B. L. 1991. South African Road Reserves: Valuable Conservation Areas? *In* Nature Conservation 2: The Role of Corridors. D. A. Saunders and R. J. Hobbs (eds.) Surrey Beatty & Sons. Chipping Norton, Australia.
- Dumas, Brett C., Gary L. Holmstead, Marie J. J. Kerr, and Leslie B. Carpenter. Revised July 2003. Effects of Road and Transmission-Line Rights-of-Way on Botanical Resources. Idaho Power Company Technical Report Appendix E.3.3-4.
- Electric Power Research Institute (EPRI). 1975. EPRI RP7826 Final Report. Study of Environmental Impact of Underground Electric Transmission Systems. May 1975.
- \_\_\_\_\_. 1992. Underground Transmission Systems Reference Book, 1992 Edition.
- \_\_\_\_\_. 2002. Wildlife and Integrated Vegetation Management on Electric Transmission Line Rights-of-Way. EPRI, Palo Alto, CA: 2002. 1005366.



- 
- \_\_\_\_\_. 2003. Landscape Fragmentation and Electric Transmission Corridor Siting and Management Technical Report. EPRI, Palo Alto, CA: 2003. 1005371.
- Florida Electric Utilities. 2007. Undergrounding Assessment Phase 1 Final Report: Literature Review and Analysis of Electric Distribution Overhead to Underground Conversion. By InfraSource Technology. Raleigh, North Carolina.
- Forman, R. T. T., D. S. Friedman, D. Fitzhenry, J. D. Martin, A. S. Chen, and L. E. Alexander. 1997. Ecological effects of roads: toward three summary indices and an overview for North America. *In* Habitat Fragmentation, Infrastructure and the Role of Ecological Engineering. K. Canters, A. Piepers, and D. Hendriks-Heersma (eds.) Proceedings of the International Conference. Ministry of Transport, Public Works and Water Management: 40-54. Maastricht – The Hague. Delft, the Netherlands. September 17-21.
- Fort Pierce Utilities Authority. 2005. Draft report of qualitative advantages and disadvantages of converting overhead distribution facilities to underground facilities within the service territory of the Fort Pierce Utilities Authority. Hi-Line Engineering LLC. Fort Pierce, Florida.
- French, S. G. Houston, C. Johnson, J. Glasgow. 2008. EPRI-GTC tailored collaboration project: a standardized methodology for siting overhead electric transmission lines. p. 221-235 *In* J.W. Goodrich-Mahoney, L. P. Abrahamson, J. L. Ballard and S. M. Tikalsky (eds.) Proceedings of the 8<sup>th</sup> International Symposium on Environmental Concerns in Rights-of-Way Management, September 12-16, 2004, Saratoga Springs, New York. Elsevier, Oxford, UK.
- Geist, V.A. 1978. Behavior. Pages 283-296 in J.L. Schmidt and D.L. Gilbert, eds. Big Game of North America: Ecology and Management. Stackpole Books, Harrisburg, PA.
- Global Invasive Species Team. 2005. The Nature Conservancy. <http://tncweeds.ucdavis.edu>.
- Greathead, D.J. 1995. Benefits and risks of classical biocontrol. Pp 53-63 In H.M. Hokkanen and J.M. Lynch (eds.) Biological control: benefits and risks. Cambridge University Press, Cambridge, U.K.
- Graul, W.D. 1980. Grassland Management and Bird Communities. In: Workshop proceedings, management of western forests and grasslands for nongame birds. M. DeGraff and N. G. Tilghman, compilers. U.S. Department of Agriculture, Forest Service General Technical Report INT-86, Ogden, Utah. Pp. 38-47.
- Hayden-Wing Associates. 1991. Review and evaluation of the effects of Triton Oil and Gas Corporation's proposed coalbed methane field development on elk and other big game species. Unpublished report. Hayden-Wing Associates, Laramie, WY.
- Helling, C. S., P. C. Kearney, and M. Alexander. 1971. Behavior of pesticides in soil. *Adv. Agron.* 23:147-240.
- Integrated Vegetation Management on Gas Pipeline Rights-of-Way. 2002. Gas Research Institute, Des Plaines, IL: 2002. GRI-01/0096.

- 
- Johnson, Bradley W. 2006. Out of Mind? A study on the Costs and Benefits of Undergrounding Overhead Power Lines. Edison Electric Institute. Washington, D. C.
- Johnson, B. K., J. W. Kern, M. J. Wisdom, S. L. Findholt, and J. G. Kie. 2000. "Resource Selection and Spatial Partitioning of Mule Deer and Elk During Spring." *Journal of Wildlife Management*. Volume 64: 685-697. The Wildlife Society. Bethesda, MD.
- Kiessling, R., P. Nefzger, J. F. Nolasco and U. Kaintzyk. 2003. *Overhead Power Lines: Planning, Design, Construction*. Springer. New York, NY.
- Knight, R. L., F. W. Smith, S. W. Buskirk, W. H. Romme, and W. L. Baker (eds.). 2000. *Forest Fragmentation in the Southern Rocky Mountains*. University Press of Colorado. Boulder, CO.
- Knock, S.T., D.S. Dobkin, J.T. Rotenberry, M.A. Schroeder, W.M.V. Haegen, and C. Van Riper III. 2003. Teetering on the Edge or Too Late? Conservation and Research Issues for Avifauna of Sagebrush Habitats. *Condor* 105: 611-634.
- Kramer, S.R., McDonald, W.J., Thomson, J.C. 1992. *An Introduction to Trenchless Technology*. Van Nostrand Reinhold. New York, NY.
- Lathrop, Earl W. and Edwin F. Archbold. 1980. Plant response to utility right-of-way construction in the Mojave Desert. *Environmental Management* Vol. 4(3): 215-226.
- Liguori, S. and Burruss, J. 2008. PacifiCorp's bird management program: integrating reactive, proactive, and preventative measures to reduce avian mortality on power lines. p. 325-329 *In* J. W. Goodrich-Mahoney, D. F. Mutrie and C. A. Guild (eds.) *Proceedings of the 7<sup>th</sup> International Symposium on Environmental Concerns in Rights-of-Way Management*, September 9-13, 2000, Calgary, Alberta, Canada.
- Lockwood, J.A. 1993. Environmental issues involved in biological control of rangeland grasshoppers (*Orthoptera: Acrididae*) with exotic agents. *Environmental Entomology* 22:503-518.
- \_\_\_\_\_. 2000. Nontarget effects of biological control: what are we trying to miss? Pp. 15-30 *In* P.A. Follett and J.J. Duan (eds.) *Nontarget Effects of Biological Control*. Kluwer Academic Publishers. Boston, Massachusetts.
- Luken, James O., Andrew C. Hinton, and Douglas G. Baker. 1991. Forest edges associated with power-line corridors and implications for corridor siting. *Landscape and Urban Planning* 20: 315-324.
- Lyon, L.J. 1983. Road density models describing habitat effectiveness for elk. *Journal of Forestry*. Volume 81, Number 9.
- Mader, H.J. 1984. *Animal Isolation by Roads and Agricultural Fields*. Biological Conservation. Volume 29.

- Manville, A.M., II. 2001. Avian mortality at communication towers: steps to alleviate a growing problem. Pp. 75-86 in B.B. Levitt (editor). Cell towers B wireless convenience? or environmental hazard? Proceedings of the ACell Towers Forum, @ state of the science/state of the law, December 2, 2000, Litchfield, CT. New Century Publishing 2000, Markham, Ontario.
- Marcot, B., M. J. Wisdom, H. W. Li, and G. C. Castillo. 1994. Managing for Featured, Threatened, Endangered, and Sensitive Species and Unique Habitats for Ecosystem Sustainability. General Technical Report PNW-GTR-329. USDA Forest Service, Pacific Northwest Research Station. Portland, OR.
- Martin, Pamela. 1999. Undergrounding Public Utility Lines. Honolulu, HI: Legislative Reference Bureau.
- McCall, P. J., S. A. Vrona, and S. S. Kelley. 1981. Fate of uniformly carbon-14 ring labeled 2,4,5-Trichlorophenoxyacetic acid and 2,4-Dichlorophenoxyacetic acid. J. Agric. Food Chem. 29:100-107.
- McEvoy, P.B. and E.M. Coombs. 2000. Why things bite back: unintended consequences of biological weed control. Pp. 167-194 In P.A. Follett and J.J. Duan (eds.) Nontarget effects of biological control. Kluwer Academic Publishers. Boston, Massachusetts.
- Miller, R. H. Best Management Practices – Integrated Vegetation Management. International Society of Arboriculture. 2007. Champaign, IL.
- Murphy, M.L. and W.R. Meehan. 1991. Stream Ecosystems. American Fisheries Society Special Publication. 19:17-46.
- Nesmith, J.C.B., J.P. Shatford, and D.E. Hibbs. 2008. Stable plant communities in the Pacific Northwest. p. 37-41 In J.W. Goodrich-Mahoney, L. P. Abrahamson, J. L. Ballard and S. M. Tikalsky (eds.) Proceedings of the 8<sup>th</sup> International Symposium on Environmental Concerns in Rights-of-Way Management, September 12-16, 2004, Saratoga Springs, New York. Elsevier, Oxford, UK.
- Nickerson, Norton H., Ross A. Dobbertein, and Nancy M. Jarman. 1989. Effects of Power-Line Construction on Wetland Vegetation in Massachusetts, USA. Environmental Management Vol. 13, No. 4, pp. 477-483.
- North Carolina Natural Disaster Preparedness Task Force. 2003. The Feasibility of Placing Electric Distribution Facilities Underground. By the North Carolina Public Staff Utilities Commission. Raleigh, North Carolina.
- Noss, R.F. and A.Y. Copperrider. 1994. Saving Nature's Legacy. Island Press. Washington, DC: Island Press.
- Olson, B.E. 1999. Impacts of Noxious Weeds on Ecologic and Economic Systems, p. 4-18 In R.L. Sheley and J.K. Petroff (eds.) Biology and Management of Noxious Rangeland Weeds. Oregon State University Press, Corvallis, OR.

- 
- Parker, L. W., and K. G. Doxtader. 1983. Kinetics of the microbial degradation of 2, 4-D in soil: effects of temperature and moisture. *J. Environ. Qual.* 12(4):553-558.
- Parker, P.L., King, T.F., Revised 1998. Guidelines for Evaluating and Documenting Traditional Cultural Properties, National Register Bulletin, National Register of Historic Places, National Park Service, U.S. Department of the Interior, Washington D.C.
- Pemberton, R.W. 1985. Native weeds as candidates for biological control research. pp. 869-877. In E.S. Delfosse (ed.) Proceedings of the VI International Symposium on the Biological Control of Weeds. August 19-25, 1984, Vancouver, Canada. Agriculture Canada.
- Peterson, A.M. 1993. The effects of electric transmission rights-of-way on trout in forested headwater streams in New York. P.315-318 In G. J. Doucet, C. Séguin and M Giguère (eds.) Proceedings of the 5<sup>th</sup> International Symposium on Environmental Concerns in Rights-of-Way Management, September 19-22, 1993, Montreal, Quebec, Canada.
- Reed, R. A., J. Johnson-Barnard, and W. L. Baker. 1996. Contribution of Roads to Forest Fragmentation in the Rocky Mountains. *Conservation Biology*. Volume 10, Number 4.
- Roig-Soles, J. and Navazo-Lopez, V. 1997. A five-year Spanish research project on bird electrocution and collision with electric lines. p. 317-325 In J.R. Williams, J. W. Goodrich-Mahoney, J. R. Wisniewski, and J. Wisniewski (eds.) Proceeding of the VI International Symposium on Environmental Concerns in Rights-of-Way Management, February 24-26, 1997, New Orleans, Louisiana, Elsevier Science Ltd, New York.
- Rowland, M. M., M. J. Wisdom, B. K. Johnson and J. G. Kie. 2000. Elk Distribution and Modeling in Relation to Roads. *Journal of Wildlife Management*. Volume 64, Number 3.
- Rudis, V.A. 1995. Regional Forest Fragmentation Effects on Bottomland Hardwood Community Types and Resource Values. *Landscape Ecology*. Volume 10, Number 5.
- Segelbacher, G., J. Høglund, and I. Storch. 2003. From connectivity to isolation: genetic consequences of population fragmentation in Capercaillie across Europe. *Molecular Ecology*. 12: 1773–1780.
- Soulé, M.E., ed. 1986. *Conservation Biology: The science of scarcity and diversity*. Sunderland, MA: Sinauer Associates. Sunderland, MA.
- Stahlecker, D.W. 1978. Effects of a new transmission line on wintering prairie raptors. *Condor* 80(4):444-446. Internet Website:  
<http://elibrary.unm.edu/sora/Condor/files/issues/v080n04/p0444-p0446.pdf>.
- Steenhof, K., M. N. Kochert, and J. A. Roppe. 1993. Nesting by raptors and common ravens on electrical transmission line towers. *Journal of Wildlife Management* 57(2):271-281. Internet Website:  
[http://www.energy.ca.gov/research/environmental/avian\\_bibliography/one\\_rec.php?InNum=3701](http://www.energy.ca.gov/research/environmental/avian_bibliography/one_rec.php?InNum=3701).

- Stylinski, Cathlyn D. and Edith B. Allen. 1999. Lack of native species recovery following severe exotic disturbance in southern Californian shrublands. *Journal of Applied Ecology* 36: 544-554.
- Taylor, A. W., and D. E. Glotfelty. 1988. Evaporation from soils and crops. Chapter 4 in *Environmental chemistry of herbicides, Vol I*. R. Grover (ed.) CRC Press, Boca Raton, Fla.
- Thibodeau, Francis R. and Norton H. Nickerson. 1986. Impact of power utility rights-of-way on wooded wetlands. *Environmental Management*. Vol. 10, No. 6, pp. 809-814.
- Tilman, D., R. M. May, C.L. Lehman, and M. A. Nowak. 1994. Habitat destruction and the extinction debt. *Nature*. 371: 65–66.
- U.S. Department of Energy and U.S. Department of the Interior, Bureau of Land Management. 2007. Programmatic Environmental Impact Statement, Designation of Energy Corridors on Federal Land in the 11 Western States (DOE/EIS-0386). Draft October 2007. Internet Website: <http://corridoreis.anl.gov/eis/guide/index.cfm>.
- U.S. Forest Service (USFS). 1995. Agriculture Handbook Number 701 – Landscape Aesthetics, a Handbook for Scenery Management. USFS.
- van der Zande, A. N., W. J. Ter Keurs, W. J. and van der Weijden. 1980. The Impact of Roads on the Densities of Four Bird Species in an Open Field Habitat: Evidence of a Long Distance Effect. *Biological Conservation* 18: 299-321.
- Ware, G. W. 1991. *Fundamentals of Pesticides: A Self-instruction Guide*. Thomson Publications. Fresno, California. 307 pgs.
- Waters, T. F. 1995. *Sediment in Streams*. American Fisheries Society Monograph 7. Bethesda, Maryland.
- Watters, M.E., T.E. McLash, C.L. Aldridge, and R.M. Brigham. 2002. The effects of vegetation structure on predation of artificial Greater Sage Grouse nest predation. *Ecoscience*. 9:314-319.
- Weller, C., J. Thomson, P. Morton, and G. Aplet. 2002. *Fragmenting our lands: the ecological footprint from oil and gas development – a spatial analysis of a Wyoming gas field*. The Wilderness Society. Washington, DC.
- Willyard, Cassandra J., Susan M. Tikalsky, and Patricia A. Mullins. 2004. Ecological effects of fragmentation related to transmission line rights-of-way: a review of the state of the science. *Wisconsin Focus on Energy Environmental Research Program*.
- Willyard, C. J. and S. M. Tikalsky. 2008. Research gaps regarding the ecological effects of fragmentation related to transmission –line rights-of-way. p. 521-527 *In* J.W. Goodrich-Mahoney, L. P. Abrahamson, J. L. Ballard and S. M. Tikalsky (eds.) *Proceedings of the 8<sup>th</sup>*

- International Symposium of Environmental Concerns in Rights-of-Way Management, September 12-16, 2004, Saratoga Springs, New York. Elsevier, Oxford, UK.
- Wisconsin Public Service Commission. 2004. Underground Electric Transmission Lines.
- Wisdom, M. J., R. S. Holthausen, and B. K. Wales. 2000. Source Habitats for Terrestrial Vertebrates of Focus in the Interior Columbia Basin: Broad-Scale Trends and Management Implications. General Technical Report, PNW GTR-485. USDA Forest Service, Pacific Northwest Research Station. Portland, OR.
- Working Group on Southwest Connecticut and the Task Force on Long Island Sound. 2003. Comprehensive Assessment and Report Part I. Energy Resources and Infrastructure of Southwest Connecticut. Institute for Sustainable Energy, Eastern Connecticut State University.
- Yahner, Richard H., Russel J. Hutnik, Stephen A. Liscinsky. 2002. Bird populations associated with an electric transmission right-of-way. *Journal of Arboriculture* 28(3): 123-130.

**Appendix B – Discussion of Available Underground Cable  
Systems**

## I. EXTRUDED DIELECTRIC CABLE SYSTEMS

HVED cable installations in the US are commonly in concrete encased duct banks because direct burial and tunnel installations have not proven reliable or economically feasible. Therefore, this report will look solely at HVED cable systems from a duct bank installation standpoint.

HVED cables have been used extensively in North America at voltages 138 kV and higher since the mid-1980s, and have seen extensive use overseas since the 1970's. XLPE-insulated cables have been used at 500 kV and higher throughout the world since the late 1990's. Two long, over 25 miles, 500kV installations have been in service in Japan since 2001. Installation of several major 345kV XLPE cable systems, totaling more than 100 circuit miles, have been installed in the US in the last 10 years.

### A. Cable

The components of a typical dielectric cable are shown in Figure B1-1. The typical cable consists of a stranded copper or aluminum conductor, inner semi-conducting conductor shield, extruded solid dielectric insulation, outer semi-conducting shield, a metallic moisture barrier, and a protective jacket.

Insulation materials used for solid dielectric cables include:

- Thermoplastic Polyethylene Compounds

Typical thermoplastic polyethylene insulation materials are low density polyethylene (LDPE), high molecular weight polyethylene (HMWPE) and high density polyethylene (HDPE).

- Thermosetting Compounds

Ethylene propylene rubber (EPR) and cross-linked polyethylene (XLPE) are typical thermosetting insulation compounds.

For voltages over 69 kV, the preferred insulation in the United States for a HVED cable system is XLPE. This is due to the higher dielectric losses associated with EPR-insulated cables.

Materials used for semi-conducting extruded conductor and insulation shields are semi-conducting PE, XLPE and EPR compounds. PE compounds are used with PE and XLPE insulation, XLPE compounds with XLPE insulation, and EPR compounds with EPR insulation.

Cable Jackets are typically extruded PE and on rare occasions polyvinyl chloride (PVC)



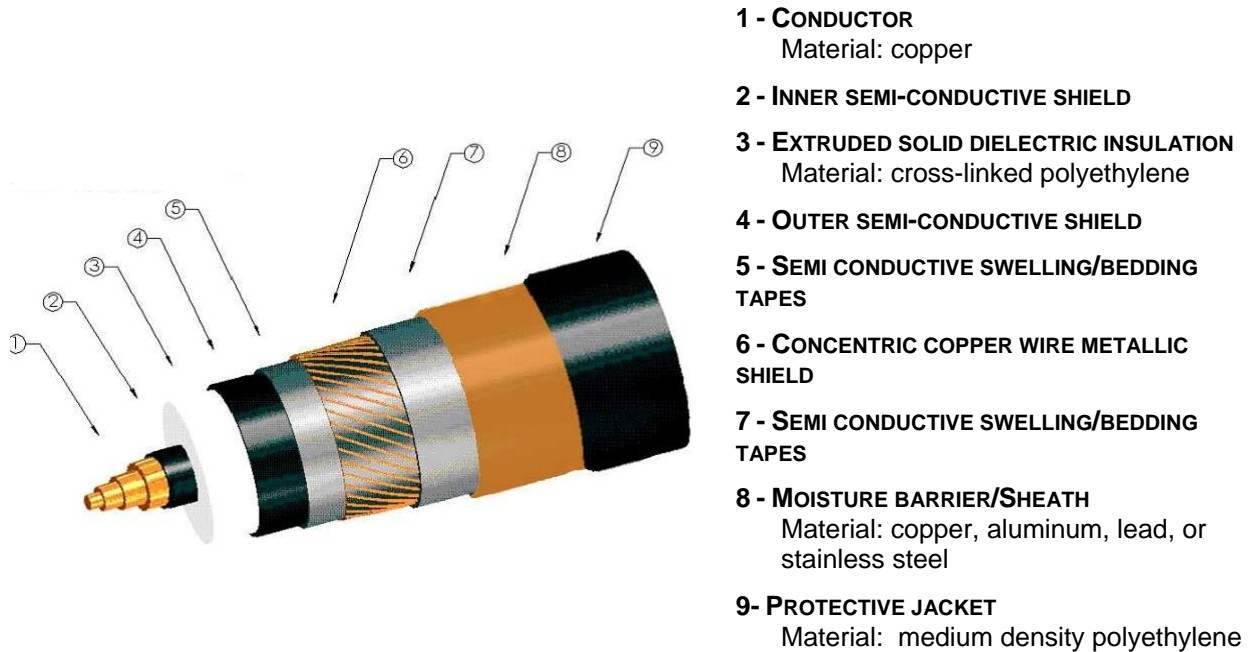

**Figure B1-1 Typical Solid Dielectric Cable Cross-Section**

The manufacturing process for extruded cables is of critical importance in ensuring a reliable end product. Triple extrusion is the preferred and recommended technique. Most transmission cable manufacturers use this “true triple head” extrusion technique today. Microscopic voids and contaminants can lead to cable failures. As such, quality control during manufacture of extruded dielectric cables is critical to minimize moisture contamination, voids, contaminants and protrusions. Manufacturers minimize insulation contamination by using super clean insulation compounds; transporting and storing the compounds in sealed facilities; and screening out contaminants at the extruder head.

## **B. Cable Accessories**

The three basic cable accessories for extruded dielectric cables are splices, terminations and sheath bonding materials.

### Splices

Pre-fabricated or pre-molded splices are commonly used to joint extruded dielectric cables. Cable preparation for these types of splices is generally the same. Insulation and shields are removed from the conductor; and the insulation is penciled. The conductor ends are then joined by a compression splice or MIG welding (aluminum conductor only). An advantage of these types of splices is that all parts can be factory tested prior to field installation. Figure B1-2 shows a typical pre-molded splice.



**Figure B1-2 Typical Pre-molded 345kV XLPE Splice**

### Terminations

Terminations are available for extruded dielectric cable to allow transitions to overhead lines or above ground equipment. Termination bodies are typically made of porcelain or polymer and include skirts to minimize the probability of external flashovers due to contamination. Figure B1-3 shows a typical XLPE termination.



**Figure B1-3 Typical 345kV XLPE Termination**

### Sheath Bonding

Another important component of an HVDC cable system is the grounding/bonding of the cable shield. A typical underground distribution system grounds the shield at each splice and termination point. However, bonding method, known as multi-point bonding, enables circulating currents to be developed on the cable shield resulting in additional heating in the cable and ultimately resulting in reduced power transfer. The way to maximize the ampacity of an underground cable is to eliminate the circulating currents. This is accomplished by using special bonding methods such as single-point and cross-bonding. These methods eliminate or reduce the amount of current, which would flow on the cable shield resulting in no or limited additional heating and therefore higher ampacity ratings.

## **II. SELF CONTAINED FLUID FILLED (SCFF) CABLE SYSTEM**

### **A. Introduction**

While AC SCFF cable has historically been used extensively outside of the United States, there are very few SCFF currently in operation in the US. As older SCFF lines are retired, they are being replaced with XLPE-insulated cables. SCFF cables have been manufactured for AC system voltages from 69 kV up to 525 kV, and tested up to 1100 kV. There is one relatively short 525-kV SCFF AC cable installation in the US, in Grand Coulee Dam.

### **B. Cable**

A SCFF cable system consists of installing three individual single-core cables in a duct system or direct buried.

The SCFF cable consists of a hollow copper conductor which is filled with dielectric fluid typically pressurized to 3-60 psig, high quality Kraft paper or laminated paper polypropylene insulation, outer shielding, and a sheath which is covered by a plastic jacket. Cable jackets are typically extruded polyethylene (PE). The metallic sheath is typically aluminum or an extruded lead-alloy. In this construction the metallic sheath serves both as a hermetic moisture seal and as a pressure containment vessel. In the case of a lead sheath, bronze tapes are frequently required to strengthen the lead sheath and to keep it from deforming due to the cable pressure.

While cables with Kraft paper had a proven track record at voltages below 345kV, the industry identified in the mid 1980's that in order to achieve higher voltages a new insulation was needed to reduce the dielectric losses of the insulation. In 1985, a new paper insulation, laminated paper polypropylene (LPP), was introduced to the paper cable industry for use on EHV cables. LPP insulation utilizes a composite construction involving a layer of low-loss, electrical-grade, homocast polypropylene film (unoriented), bonded without adhesive between two layers of high-purity Kraft electrical-insulating paper. This laminate tape looks and handles like a paper-insulating tape of equal thickness. The LPP composite is manufactured by laminating an extruded polypropylene film that is sandwiched, while hot, between two cellulose-paper layers. The three layers are bonded using two pressure rollers. No adhesive or copolymer materials are used in making the LPP laminate.

The major advantages of LPP over conventional paper in EHV cables are due to the polypropylene film and include the following:

- Lower dielectric loss
- Higher ac and impulse strength
- Thinner insulation walls
- Higher ampacity ratings

In a SCFF cable, the central duct is filled with dielectric fluid. This fluid is allowed to flow through the wires of the conductor into the insulation. The volumetric change in the fluid due to the heating effects of load currents is compensated by connecting the duct to fluid reservoirs or tanks at intervals along the route using special “stop” or feed joints or at the ends of the route. When the cable cools, the fluid is driven back into the cable by maintaining the reservoirs at a positive pressure at all temperatures. The pressure is kept as low as possible, consistent with the profile of the route, and the minimum pressure is typically 3 psig. A low-viscosity impregnant is chosen to ensure that the fluid may flow readily through the duct, especially during heating and cooling transients and thus maintain the internal pressure within the design range. As the fluid flows freely throughout the insulation, the cable has some self-healing properties, because there are no voids in the insulation or joints. Figure B1-4 shows a typical cross-section of a SCFF cable.

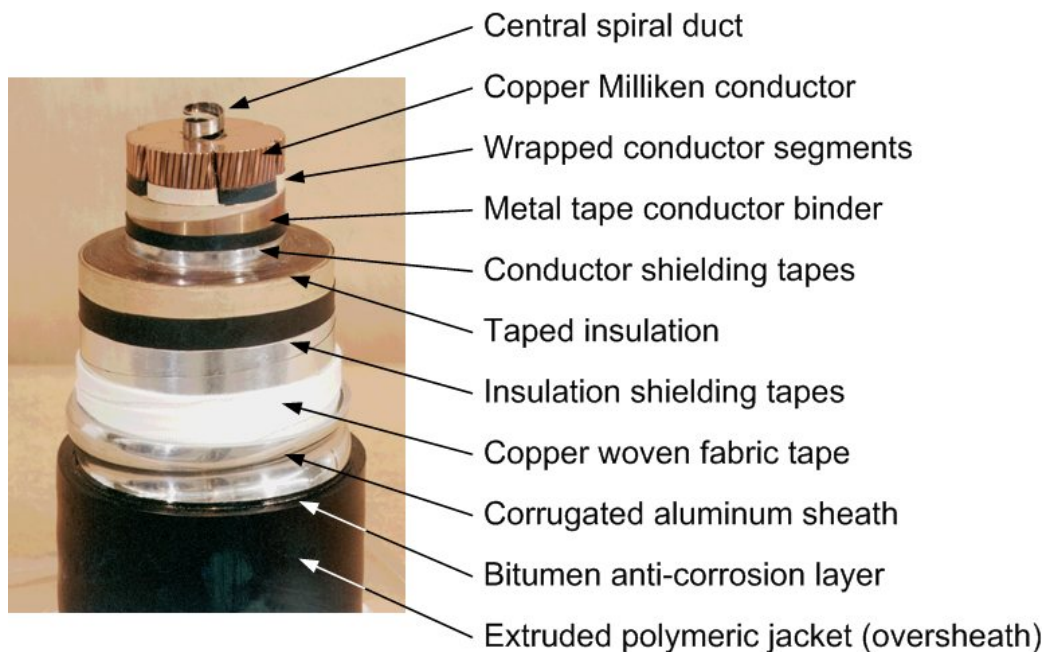

**Figure B1-4 Typical SCFF Cable Cross-Section**

The manufacturing process is as follows: a conductor core is helically wound with layers of metalized or carbon black paper tape for the conductor; high quality Kraft paper or paper/polypropylene laminate is then helically wound around the conductor in multiple layers for the insulation; additional layers of metalized or carbon black paper tape helically wound around the insulation to form the insulation shield. Prior to the installation of the sheath and jacket, the cable is dried and placed into impregnating tanks. After the cable is impregnated with the appropriate dielectric fluid, fabric tapes are wound around the core to provide a bedding layer to absorb any expansion and contraction of the cable core under the sheath. The outer sheath and jacket is then extruded on to the core.

As well as electrical performance, it is necessary for the cable to have a satisfactory mechanical performance. For large insulation thicknesses, it is usually necessary to have thicker paper tapes on the outside of the cable to achieve this. Thus the density of the papers may be varied in the wall of the insulation.

### **C. Cable Accessories**

The three basic cable accessories for extruded dielectric cables are splices, terminations and sheath bonding materials.

Splicing of each SCFF cable begins with removal of the outer sheath and jacket and the insulation is step-penciled. The conductor ends are then joined by compression connector or MIG welding (aluminum conductor only). Insulation paper tape is wound around the spliced conductor, filling the step-penciled area of the insulation. Metalized tapes or carbon black tapes are used to re-establish the conductor and insulation shields. An outer joint casing is placed around the jointed cable to provide a continuation of the outer sheath and contain the fluid in the cable.

Terminations are available for SCFF cable to allow transitions to overhead lines or above ground equipment. Termination bodies are typically made of porcelain and include skirts to minimize the probability of external flashovers due to contamination.

Once the cable installation is completed the cable is filled with filtered synthetic dielectric fluid and pressurized to a nominal 2-60 psig depending on the cable system design. To maintain these pressures during the operation of the cable system, pressure reservoirs are placed at one end, at intermediate locations or at both ends depending on the cable system design. If significant elevation changes exist along the route, reservoirs may be required at these locations as well. If higher pressures are needed, a special pressurization plant is needed. Regardless of the type of pressurization system, a monitoring system is required at each pressurization point. The monitoring equipment controls the operation of the system and communicates the system status to the utility. This is the biggest disadvantage of the SCFF system.

Another important component of a SCFF cable system is the grounding/bonding of the cable shield. Unlike an underground distribution system, which grounds the shield at each splice and termination, an underground transmission line requires alternative grounding/bonding methods. Grounding at each splice and terminations causes circulating currents to be developed on the cable shield resulting in additional heating in the cable and lower ampacity. The way to maximize the ampacity of an underground cable is to eliminate the circulating currents. This is accomplished with underground transmission cables by using special bonding methods such as single-point and cross-bonding. These methods eliminate or reduce the amount of current, which would flow on the cable shield resulting in no or limited additional heating and ultimately a higher ampacity.

When connecting a SCFF cable system directly to an overhead line, a small fenced transition station consisting of an A-frame structure and termination stand. The pressure reservoirs would be mounted near each termination. A larger transition station would be required if a larger pressurization plant would be required.

### III. GAS INSULATED TRANSMISSION LINE (GITL)

#### A. Introduction

Gas Insulated Transmission Lines (GITL) have been in commercial use in the US since the 1970's. These lines consist of an aluminum pipe containing a single-phase conductor with a pressurized, insulating gas. The technology is similar to gas insulated bus bars used to connect gas insulated switchgear (GIS). GITLs are well suited for high power applications and are most commonly used in tunnel, underground, and substation installations.

#### B. GITL Conductor

GITL systems are typically manufactured in pre-assembled 60 foot lengths of single core aluminum pipe. The aluminum pipe enclosure is similar to those used for bus conductors at substations. These sections are typically connected by automated welds, though they can be connected through flanges as an alternative. Above ground installations must take into account the thermal expansion and stress that the pipe will encounter through the installation of metallic bellows. The aluminum conductor and aluminum casing are both electrically and mechanically isolated through the use of epoxy insulators. The epoxy insulators are enclosed entirely within the casing, so they are immune to degradation from water, sunlight, or any other environmental factors. They are designed to have an approximate service life of 50 years. The aluminum conductor and enclosure will be exposed to different temperature changes based on peak load requirements and ambient temperatures, so the spacers mechanically isolate the two by being able to slide or roll along the interior of the enclosure pipe allowing the two to expand independently. Epoxy spacers are required approximately every 20 feet to properly support the conductor. Figure B1-5 shows a typical construction of GITL.

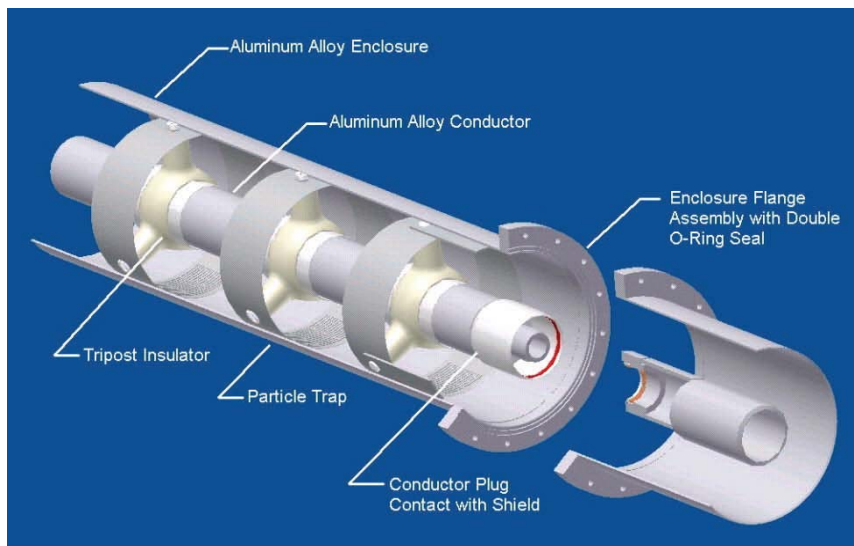

**Figure B1-5 Typical GITL (Image Courtesy of AZZ)**

Because the pipe is fairly rigid, direction changes with a radius of less than approximately 1300 feet must be made through prefabricated elbows designed to a specific angle; changes in direction that allow for a larger radius can be made by simply flexing the enclosure pipe during installation. Prefabricated elbows

are made in shorter sections, are designed for the specific route, and are not as easy to ship as the typical GITL sections, so they tend to increase the average per length cost of the overall installation.

The aluminum enclosure pipe effectively isolates the electrical system from external environmental factors. In above ground installations, no added corrosion protection is required; however the exterior of the pipe should be visually inspected annually to check for corrosion or damage. High-current circuits may require the use of specialized paint that reflects sunlight while still emits infrared radiation depending on the thermal environment of the installation. In underground and tunnel installations, cathodic protection systems should be used to mitigate any corrosive activity from deteriorating the system. In all applications, the enclosure pipe must be grounded at either end of the route and intermittently along an installation. This allows circulating currents to flow, which does cause heating and losses in the circuit. However, this is necessary for personnel safety and has the additional effect of reducing the external magnetic fields produced by the system to negligible levels.

GITL systems use SF<sub>6</sub> and N<sub>2</sub> gas for insulation, which is widely used in high-voltage substation equipment. SF<sub>6</sub> will break into its fundamental components and recombine when exposed to an electric discharge or arc with minimal contamination. Also, the insulating properties of SF<sub>6</sub> do not weaken over time, so it will outlast the insulation of a typical underground cable. However, SF<sub>6</sub> is a strong greenhouse gas that raises major environmental concerns. To help alleviate some concerns most GITL systems use a mixture of SF<sub>6</sub> and N<sub>2</sub> to reduce the overall amount of SF<sub>6</sub> in the system. The only maintenance required for the system is the use of a gas density monitor to ensure there are no leaks and trigger an alarm if there is a 5% drop relative to the original charge of gas.

A GITL installation is a specialized line that historically has not been used as a part of a standard transmission line system. The lines are normally installed in utility controlled environments and require specialized installation practices when compared to overhead and underground cable systems. The additional overall cost and increased exposure of a GITL system makes it a less desirable option for a standard transmission line installation.

#### **IV. HIGH TEMPERATURE SUPERCONDUCTING (HTS)**

##### **A. Introduction**

Research is currently underway in the advancement of high temperature superconductors (HTS). Utilizing a unique cable design where all three phases are centered concentrically on a single core, the cables are capable of displaying low electric losses with the same power transfer capabilities as compared with a standard non-superconducting cable. The core, filled with a cryogenic fluid, super cools the conducting material resulting in extremely low losses and high electrical power transfer capacities. Most HTS systems are located adjacent to large metro areas, where they are capable of transferring large quantities of power a few thousand feet, at the distribution level. However, technological advances in the last few years have seen the first 138 kV AC system installed in Long Island, New York in early 2008. Because HTS systems have not been established at the 500kV voltage levels, nor over long distances, superconducting cable would not be a technology option to consider for BPA'S Project. Figure B1-6 shows a typical superconductor cable design.



**Figure B1-6 Typical Cable Design (Photo Courtesy of Southwire)**