



**US Army Corps
of Engineers®**
Portland District



WILLAMETTE VALLEY SYSTEM OPERATIONS AND MAINTENANCE

APPENDIX B: HYDROLOGIC PROCESSES TECHNICAL INFORMATION

TABLE OF CONTENTS

1	Introduction	1
2	Inflow Dataset.....	1
2.1	Overview	1
2.2	Assumptions.....	1
2.3	Existing Datasets and Information.....	1
2.3.1	Existing Inflow Datasets	1
2.3.2	Existing Evaporation Datasets.....	3
2.3.3	Existing Irrigation Datasets	6
2.4	Methods.....	9
2.4.1	Reservoir Inflows	9
2.4.2	Local Inflows.....	12
2.4.3	Evaporation.....	16
2.4.4	Withdrawals.....	16
2.5	Results.....	17
2.5.1	Reservoir Inflows	17
2.5.2	Reservoir Inflows	18
2.5.3	Evaporation.....	18
2.6	Local Flow Calculation Methods	19
2.6.1	Mehama	20
2.6.2	Foster Dam and Reservoir.....	21
2.6.3	Waterloo	22
2.6.4	Jefferson.....	23
2.6.5	Monroe	24
2.6.6	Vida	25
2.6.7	Lookout Point.....	26
2.6.8	Jasper	27
2.6.9	Goshen	28
2.6.10	Harrisburg	29
2.6.11	Albany	30
2.6.12	Salem.....	31
2.6.13	Oregon City	31
2.7	Water Year 2009 Validation Results	32
2.7.1	Reservoir Inflows	32
2.7.2	Local Inflows.....	38
3	No-action Alternative HEC-ResSim Model	45
3.1	Overview	45
3.2	The Period of Record in the HEC-ResSim Analysis.....	50
3.2.1	Reservoir Inflows	50
3.2.2	Water Year Classification	50
3.3	HEC-ResSim Network and Dam Specifics.....	55
3.3.1	Configuration in HEC-ResSim	55

*Willamette Valley System Operations and Maintenance
Environmental Impact Statement*

3.3.2	Routing Reaches.....	55
3.3.3	HEC-ResSim Inputs for Physical Parameters of Each Dam	59
3.3.4	Water Withdrawals and Returns	61
3.4	HEC-ResSim Network and Dam Specifics.....	62
3.4.1	Reservoir Zones in HEC-ResSim and Rules Curves.....	64
3.4.2	Re-regulating Dams.....	65
3.4.3	Release Allocations	65
3.4.4	Capacities and Minimum Gate Openings	66
3.4.5	Induced Surcharge	67
3.4.6	Downstream Control Points, Maximum Flow Rules.....	67
3.4.7	Downstream Control Points, Minimum Flow Rules.....	72
3.4.8	Rate of Flow Changes, Maximum and Minimum Flows	74
3.4.9	Minimum Project Outflows.....	74
3.4.10	E-Flows	75
3.4.11	IRRM.....	75
3.5	Dam and Reservoir-specific Modeled Operations.....	75
3.5.1	Blue River Dam and Reservoir Modeled Operations.....	75
3.5.2	Cougar Dam and Reservoir Modeled Operations.....	80
3.5.3	Dorena Dam and Reservoir Modeled Operations	87
3.5.4	Cottage Grove Dam and Reservoir Modeled Operations.....	92
3.5.5	Fall Creek Dam and Reservoir Modeled Operations	97
3.5.6	Hills Creek Dam and Reservoir Modeled Operations	103
3.5.7	Lookout Point Dam and Reservoir Modeled Operations.....	109
3.5.8	Fern Ridge Dam and Reservoir Modeled Operations.....	116
3.5.9	Green Peter Dam and Reservoir Modeled Operations.....	121
3.5.10	Foster Dam and Reservoir Modeled Operations	126
3.5.11	Detroit Dam and Reservoir Modeled Operations.....	131
3.6	HEC-ResSim NAA Simulation Results	138
4	Alternative modeling assumptions	145
4.1	Alternative 1 Modeling Assumptions	145
4.1.1	Measure 392	145
4.1.2	Measure 479	146
4.1.3	Measure 105	146
4.1.4	Measure 718	147
4.1.5	Measure 304	147
4.1.6	Measure 723	148
4.1.7	Measure 174	149
4.1.8	Measure 722	149
4.1.9	Measure 52	149
4.1.10	Basin-wide Measures 9, 384, 719, 726	150
4.2	Alternatives 2A and 2B Modeling Assumptions	150
4.2.1	Measure 30	150
4.2.2	Measure 721	151

*Willamette Valley System Operations and Maintenance
Environmental Impact Statement*

4.2.3	Measure 166	151
4.2.4	Measure 714	152
4.2.5	Measure 720	152
4.2.6	Measure 40	152
4.2.7	Measure 718	153
4.2.8	Measure 304	153
4.2.9	Measure 105	154
4.2.10	Measure 392	154
4.2.11	Measure 479	154
4.2.12	Measure 722	154
4.2.13	Measure 52	154
4.2.14	Basin-wide Measures 9, 384, 719, 726	155
4.3	Alternatives 3A and 3B Modeling Assumptions	155
4.3.1	Measure 30	155
4.3.2	Measure 721	156
4.3.3	Measure 166	156
4.3.4	Measure 714	156
4.3.5	Measure 720	156
4.3.6	Measure 40	156
4.3.7	Measure 718	157
4.3.8	Measure 304	157
4.3.9	Measure 722	157
4.3.10	Measure 52	157
4.3.11	Basin-wide Measures 9, 384, 719, 726	157
4.4	Alternative 4 Modeling Assumptions	158
4.4.1	Measure 30	158
4.4.2	Measure 721	158
4.4.3	Measure 166	158
4.4.4	Measure 392	158
4.4.5	Measure 479	159
4.4.6	Measure 105	159
4.4.7	Measure 718	159
4.4.8	Measure 304	159
4.4.9	Measure 174	160
4.4.10	Measure 711	160
4.4.11	Measure 722	160
4.4.12	Measure 52	160
4.4.13	Basin-wide Measures 9, 384, 719, 726	160
4.5	Alternative 5 Modeling Assumptions	160
4.5.1	Measure 30b	160
4.5.2	Measure 721	161
4.5.3	Measure 166	161
4.5.4	Measure 714	162
4.5.5	Measure 720	162

*Willamette Valley System Operations and Maintenance
Environmental Impact Statement*

4.5.6	Measure 40	162
4.5.7	Measure 718	162
4.5.8	Measure 304	162
4.5.9	Measure 105	163
4.5.10	Measure 392	163
4.5.11	Measure 479	163
4.5.12	Measure 722	163
4.5.13	Measure 52	163
4.5.14	Basin-wide Measures 9, 384, 719, 726	164
4.6	Alternative 6 Modeling Assumptions	164
4.6.1	No Hydropower Assumption	164
4.6.2	Measure 721	164
4.6.3	Measure 166	164
4.6.4	Measure 714	164
4.6.5	Measure 720	164
4.6.6	Measure 40	165
4.6.7	Measure 718	165
4.6.8	Measure 304	165
4.6.9	Measure 105	165
4.6.10	Measure 392	166
4.6.11	Measure 479	166
4.6.12	Measure 722	166
4.6.13	Measure 52	166
4.7	Interim Operations Modeling Assumptions	166
4.7.1	Measure 30b	166
4.7.2	Detroit Dam and Reservoir	167
4.7.3	Green Peter Dam and Reservoir	167
4.7.4	Foster Dam and Reservoir	168
4.7.5	Cougar Dam and Reservoir	169
4.7.6	Hills Creek Dam and Reservoir	170
4.7.7	Lookout Point Dam and Reservoir	170
4.7.8	Dexter Dam and Reservoir	171
4.7.9	Fall Creek Dam and Reservoir	171
4.8	Updated Interim Operations Modeling Assumptions	171
4.8.1	Detroit Dam and Reservoir	171
4.8.2	Green Peter Dam and Reservoir	172
4.8.3	Foster Dam and Reservoir	173
4.8.4	Cougar Dam and Reservoir	174
4.8.5	Hills Creek Dam and Reservoir	175
4.8.6	Lookout Point Dam and Reservoir	175
4.8.7	Dexter Dam and Reservoir	176
4.8.8	Fall Creek Dam and Reservoir	176
4.9	Modeling Discrepancies	176
4.9.1	Measure 30 Temperature Flows at Salem	176

*Willamette Valley System Operations and Maintenance
Environmental Impact Statement*

4.9.2	Measure 718	177
4.9.3	Measure 304	177
4.9.4	Measure 40	178
4.9.5	Measure 392 and 479	178
4.9.6	3 Feet/day Draft Limit Below Minimum Conservation Elevation.....	178
4.9.7	Cougar Penstock Release at or Below 1,520 Feet	178
5	Alternative Non-exceedance plots	179
5.1	Alternative 1.....	180
5.2	Alternative 2A	199
5.3	Alternative 2B	218
5.4	Alternative 3A	237
5.5	Alternative 3B	256
5.6	Alternative 4.....	275
5.7	Alternative 5.....	294
5.8	Alternative 6.....	313
5.9	Interim Operations.....	334
5.10	Interim Operations.....	354
5.11	Alternative 5 / Alternative 2B Comparison Plots.....	373
5.12	Alternative 5/Alternative 2B Non-exceedance Plots	374
5.13	Alternative 5/Alternative 2B WY 2009–2019 Plots	394
6	Qualitative Assessment of Climate Change impacts to Hydrology.....	414
6.1	No-action Alternative.....	416
6.2	Alternative 1.....	417
6.3	Alternative 2A	418
6.4	Alternative 2B	420
6.5	Alternative 3A	421
6.6	Alternative 3B	423
6.7	Alternative 4.....	424
6.8	Alternative 5.....	425
6.9	Alternative 6.....	427
7	Increase in conservation storage associated with not drawing down when above the rule curve for 14 days during refill at WVS reservoirs	440
7.1	Methods.....	441
7.2	Results and Conclusions.....	444
7.3	Additional Figures and Tables.....	445
8	Flood risk associated with holding Willamette Valley reservoirs with secondary flood storage at the top of the secondary flood pool during the winter – 1964 and 1996 case study	451
8.1	Methods.....	452
8.2	Results and Discussion	454
9	Increases in conservation storage associated with targeting the top of the secondary flood pool during the winter at WVS reservoirs	464

*Willamette Valley System Operations and Maintenance
Environmental Impact Statement*

9.1	Methods	464
9.2	Results	469
9.3	Conclusions	488
10	WVS Water Control Diagrams	490
11	Basin Description Supplementary Figures	497
12	References	506

LIST OF TABLES

Table 2-1.	WEST Monthly Evaporation Rates (inches).	3
Table 2-2.	WRCC Monthly Pan Evaporation Rates (inches) Multiplied by 0.70.	4
Table 2-3.	Evaporation Datasets Period of Record	4
Table 2-4.	Estimated Conservation Season Evaporation.....	6
Table 2-5.	Reservoir Inflow Datasets and Calculation Methods in Willamette FIS.	11
Table 2-6.	Dates When Inflow Methods Transitioned from Winter to Summer at Fall Creek Reservoir in FIS Dataset.....	12
Table 2-7.	Observed Flow Locations with HEC-DSS Pathnames to Calculate Local Flows.	14
Table 3-1.	Summary of the Specifics for the NAA Simulation.	49
Table 3-2.	No-action Alternative Simulation Start Parameters.....	49
Table 3-3.	Mainstem Biological Opinion Flow Targets for Salem and Albany.....	51
Table 3-4.	Definition of Water Year Types in the Willamette River Basin.....	51
Table 3-5.	Water Year Types for 1936–2019 and Maximum Conservation Storage Value for May 10–20, in Millions of Acre-Feet (Maf).	53
Table 3-6.	SSARR Routing Specifications.	56
Table 3-7.	Summary of Outlets by Project.....	60
Table 3-8.	Top of WVS Dams’ Elevation (ft, NGVD) and Length (ft).	61
Table 3-9.	Zone Types Used in Operation Sets.	64
Table 3-10.	Sequential Release Allocation for All Model Runs.....	66
Table 3-11.	Project Operation for Control Point Maximum Flows.....	70
Table 3-12.	Project Operation for Control Point Minimum Flows.	73
Table 3-13.	Blue River Reservoir Zone Elevations.	76
Table 3-14.	Cougar Reservoir Zone Elevations.	82
Table 3-15.	Dorena Reservoir Zone Elevations.....	89
Table 3-16.	Cottage Grove Reservoir Zone Elevations.	94
Table 3-17.	Fall Creek Reservoir Zone Elevations.	99
Table 3-18.	Hills Creek Reservoir Zone Elevations.....	104
Table 3-19.	Lookout Point Reservoir Zone Elevations.	111
Table 3-20.	Fern Ridge Reservoir Zone Elevations.	118
Table 3-21.	Green Peter Reservoir Zone Elevations.	122
Table 3-22.	Foster Reservoir Zone Elevations.....	128

*Willamette Valley System Operations and Maintenance
Environmental Impact Statement*

Table 3-23. Detroit Reservoir Zone Elevations.	133
Table 4-1. HD531 Mainstem Targets.	149
Table 4-2. Alternatives 2A and 2B Drawdowns.	150
Table 4-3. Alternatives 3A and 3B Drawdowns.	155
Table 6-1. Storage and Differences due to Climate Change under the NAA.	417
Table 6-2. Storage and Flow Differences due to Climate Change under Alternative 1.	418
Table 6-3. Storage and Flow Differences due to Climate Change for Alternative 2A.	419
Table 6-4. Storage and Flow Differences due to Climate Change for Alternative 2B.	421
Table 6-5. Storage and Flow Differences due to Climate Change for Alternative 3A.	422
Table 6-6. Storage and Flow Differences due to Climate Change for Alternative 3B.	424
Table 6-7. Storage and Flow Differences due to Climate Change under Alternative 4.	425
Table 6-8. Storage and Flow Differences due to Climate Change under Alternative 5.	426
Table 6-8. Storage and Flow Differences due to Climate Change under Alternative 6.	427
Table 7-1. kaf Converted to cfs Sustainable over 30 Days.	442
Table 7-2. Increases in System Conservation Storage Associated with Alternative Operations in Insufficient and Deficit Water Years.	444
Table 7-3. Mean Increase in Conservation Storage Associated with Alternative Operations in Insufficient and Deficit Water Years.	444
Table 7-4. May Increase in Conservation Storage Associated with Alternative Operations at Blue River Dam and Reservoir in Insufficient and Deficit Years.	445
Table 7-5. May Increase in Conservation Storage Associated with Alternative Operations at Cougar Dam and Reservoir Insufficient and Deficit Years.	445
Table 7-6. May Increase in Conservation Storage Associated with Alternative Operations at Cottage Grove Dam and Reservoir.	446
Table 7-7. May Increase in Conservation Storage Associated with Alternative Operations at Detroit Dam and Reservoir.	447
Table 7-8. May Increase in Conservation Storage Associated with Alternative Operations at Dorena Dam and Reservoir.	447
Table 7-9. May Increase in Conservation Storage Associated with Alternative Operations at Fall Creek Dam and Reservoir.	448
Table 7-10. April Increase in Conservation Storage Associated with Alternative Operations at Fern Ridge Dam and Reservoir.	449
Table 7-11. May Increase in Conservation Storage Associated with Alternative Operations at Green Peter Dam and Reservoir.	449
Table 7-12. May 15 Increase in Conservation Storage Associated with Alternative Operations at Hills Creek Dam and Reservoir.	450
Table 7-13. May Increase in Conservation Storage Associated with Alternative Operations at Lookout Point Dam and Reservoir.	451
Table 8-1. Flood Regulation Goals at Willamette Valley System Dams and Reservoirs.	453
Table 9-1. Minimum Flows Required to Meet BiOp and Projected 2070 Withdrawals at Detroit Dam and Reservoir.	466

*Willamette Valley System Operations and Maintenance
Environmental Impact Statement*

Table 9-2. Minimum Flows Required to Meet BiOp and Projected 2070 Withdrawals at Green Peter/Foster Dams and Reservoirs ¹	466
Table 9-3. Minimum Flows Required to Meet Biological Opinion and Projected 2070 Withdrawals at Blue River Dam and Reservoir.	466
Table 9-4. Minimum Flows Required to Meet Biological Opinion and Projected 2070 Withdrawals at Cougar Dam and Reservoir ²	466
Table 9-5. Minimum Flows Required to Meet BiOp and Projected 2070 Withdrawals at Hills Creek Dam and Reservoir.	467
Table 9-6. Minimum Flows Required to Meet BiOp and Projected 2070 Withdrawals at Lookout Point Dam and Reservoir.	467
Table 9-7. Minimum Flows Required to Meet BiOp and Projected 2070 Withdrawals at Albany ³	467
Table 9-8. Minimum Flows Required to Meet BiOp and Projected 2070 Withdrawals at Salem.	467
Table 9-9. 1,000 Acre-Feet (kaf) Converted to cfs Sustainable over 30 days.	467
Table 9-10. April Increase in Conservation Storage Associated with Alternative Operations at Blue River Dam and Reservoir (“Fill” means that the reservoir fills under the baseline).	470
Table 9-11. April Increase in Conservation Storage Associated with Alternative Operations at Cougar Dam and Reservoir (“Fill” means that the reservoir fills under the baseline).	473
Table 9-12. April Increase in Conservation Storage Associated with Alternative Operations at Detroit Dam and Reservoir (“Fill” means that the reservoir fills under the baseline).	475
Table 9-13. April Increase in Conservation Storage Associated with Alternative Operations at Green Peter Dam and Reservoir (“Fill” means that the reservoir fills under the baseline).	478
Table 9-14. April Increase in Conservation Storage Associated with Alternative Operations at Hills Creek Dam and Reservoir (“Fill” means that the reservoir fills under the baseline).	481
Table 9-15. April Increase in Conservation Storage Associated with Alternative Operation at Lookout Point Dam and Reservoir (“Fill” means that the reservoir fills under the baseline).	483
Table 9-16. April Increase in Conservation Storage Associated with Alternative Operation at WVS Reservoirs with Secondary Flood Pools.	486
Table 9-17. Number of Years with Increased Storage Attributed to Alternative Operations and Average Increase by Water Year Type.	489
Table 10-1. Project Datum Conversions (USACE 2018b).	491

LIST OF FIGURES

*Willamette Valley System Operations and Maintenance
Environmental Impact Statement*

Figure 2-1. Monthly Pan Evaporation as a Function of Maximum Daily Temperatures Averaged over the Month at Salem. 5

Figure 2-2. Historical Minus 2008 Irrigation Withdrawals and Return Flows above Fern Ridge Dam and Reservoir. 7

Figure 2-3. Historical Minus 2008 Irrigation Withdrawals and Return Flows above Albany (not including above Fern Ridge Dam and Reservoir). 8

Figure 2-4. Historical Minus 2008 Irrigation Withdrawals and Return Flows between Salem and Albany. 8

Figure 2-5. Increase in Irrigation Withdrawals between 2008–2018 at Oregon City Falls..... 17

Figure 2-6. Three Example Years (1995–1997) of Calculated Evaporation from Fern Ridge Reservoir..... 18

Figure 2-7. Fern Ridge Reservoir Daily Evaporation in CFS..... 19

Figure 2-8. Mehama Routing Diagram..... 20

Figure 2-9. Foster Dam and Reservoir Routing Diagram. 21

Figure 2-10. Waterloo Routing Diagram..... 22

Figure 2-11. Jefferson Routing Diagram. 23

Figure 2-12. Monroe Routing Diagram. 24

Figure 2-13. Vida Routing Diagram. 25

Figure 2-14. Lookout Point Dam and Reservoir Routing Diagram..... 26

Figure 2-15. Jasper Routing Diagram..... 27

Figure 2-16. Goshen Routing Diagram..... 28

Figure 2-17. Harrisburg Routing Diagram. 29

Figure 2-18. Albany Routing Diagram. 30

Figure 2-19. Salem Routing Diagram. 31

Figure 2-20. Oregon City Routing Diagram..... 32

Figure 2-21. Water Year 2009 Comparison at Detroit Reservoir..... 33

Figure 2-22. Water Year 2009 Comparison at Green Peter Reservoir. 33

Figure 2-23. Water Year 2009 Comparison at Fern Ridge Reservoir..... 34

Figure 2-24. Water Year 2009 Comparison at Cougar Reservoir..... 34

Figure 2-25. Water Year 2009 Comparison at Blue River Reservoir..... 35

Figure 2-26. Water Year 2009 Comparison at Fall Creek Reservoir. 35

Figure 2-27. Water Year 2009 Comparison at Hills Creek Reservoir. 36

Figure 2-28. Water Year 2009 Comparison at Dorena Reservoir. 36

Figure 2-29. Water Year 2009 Comparison at Cottage Grove Reservoir..... 37

Figure 2-30. Water Year 2009 Comparison at Mehama, OR. 38

Figure 2-31. Water Year 2009 Comparison at Local Inflow at Foster Dam and Reservoir..... 39

Figure 2-32. Water Year 2009 Comparison at Jefferson, OR..... 39

Figure 2-33. Water Year 2009 Comparison at Monroe, OR..... 40

Figure 2-34. Water Year 2009 Comparison at Vida, OR. 40

Figure 2-35. Water Year 2009 Comparison at Local Inflow at Lookout Point Dam and Reservoir. 41

*Willamette Valley System Operations and Maintenance
Environmental Impact Statement*

Figure 2-36. Water Year 2009 Comparison at Jasper, OR.	41
Figure 2-37. Water Year 2009 Comparison at Goshen, OR.	42
Figure 2-38. Water Year 2009 Comparison at Harrisburg, OR.	42
Figure 2-39. Water Year 2009 Comparison at Albany, OR.	43
Figure 2-40. Water Year 2009 Comparison at Salem, OR.	44
Figure 2-41. Water Year 2009 Comparison at Oregon City, OR.	45
Figure 3-1. HEC-ResSim Network for the NAA Simulation.	47
Figure 3-2. Total Conservation Storage in the Willamette River Basin USACE Dams and Reservoirs, by Date and Graphical Water Year Type Definition.	52
Figure 3-3. Schematic of SSARR Routing Applied to a Portion of a Stream.	56
Figure 3-4. Generic Storage Graph of a Willamette Dam and Reservoir. Note the rule curve, the heavy red line, is shaped slightly differently for each project, and refill and draft schedules also vary by project. Projects without a powerhouse do not have a power pool, shown in green in the graph.	62
Figure 3-5. Typical Example Graph of Reservoir Zones.	64
Figure 3-6. Willamette River Basin Schematic.	69
Figure 3-7. HEC-ResSim Screen Shots of Downstream Maximum Rules.	71
Figure 3-8. HEC-ResSim Screen Shots of Downstream Maximum Rules, Continued.	72
Figure 3-9. HEC-ResSim Screen Shot of Minimum Flow—at Salem by Water Year Type Rule. ...	73
Figure 3-10. HEC-ResSim Screen Shot of Minimum Flow—at Albany by Water Year Type Rule. ...	74
Figure 3-11. Blue River Dam and Reservoir Operational Summary.	76
Figure 3-12. Blue River Dam and Reservoir HEC-ResSim Water Control Diagram.	76
Figure 3-13. Blue River Dam and Reservoir NAA Operation Set Rules.	79
Figure 3-14. Blue River Dam and Reservoir NAA Operation Set Rules, Continued.	80
Figure 3-15. Cougar Dam and Reservoir Operational Summary.	81
Figure 3-16. Cougar Dam and Reservoir HEC-ResSim Water Control Diagram.	82
Figure 3-17. Cougar Dam and Reservoir NAA Operation Set Rules.	85
Figure 3-18. Cougar Dam and Reservoir NAA Operation Set Rules, Continued.	86
Figure 3-19. Cougar Dam and Reservoir NAA Operation Set Rules, Continued.	87
Figure 3-20. Dorena Dam and Reservoir Operational Summary.	88
Figure 3-21. Dorena Dam and Reservoir HEC-ResSim Water Control Diagram.	88
Figure 3-22. Dorena Dam and Reservoir NAA Operation Set Rules.	91
Figure 3-23. Dorena Dam and Reservoir NAA Operation Set Rules, Continued.	92
Figure 3-24. Cottage Grove Dam and Reservoir Operational Summary.	93
Figure 3-25. Cottage Grove Dam and Reservoir HEC-ResSim Water Control Diagram.	93
Figure 3-26. Cottage Grove Dam and Reservoir NAA Operation Set Rules.	96
Figure 3-27. Cottage Grove Dam and Reservoir NAA Operation Set Rules, Continued.	97
Figure 3-28. Fall Creek Dam and Reservoir Operational Summary.	98
Figure 3-29. Fall Creek Dam and Reservoir HEC-ResSim Water Control Diagram.	98
Figure 3-30. Fall Creek Dam and Reservoir NAA Operation Set Rules.	101
Figure 3-31. Fall Creek Dam and Reservoir NAA Operation Set Rules, Continued.	102

*Willamette Valley System Operations and Maintenance
Environmental Impact Statement*

Figure 3-32. Hills Creek Dam and Reservoir Operational Summary.....	103
Figure 3-33. Hills Creek Dam and Reservoir HEC-ResSim Water Control Diagram.	104
Figure 3-34. Hills Creek Dam and Reservoir NAA Operation Set Rules.	107
Figure 3-35. Hills Creek Dam and Reservoir NAA Operation Set Rules, Continued.	108
Figure 3-36. Hills Creek Dam and Reservoir NAA Operation Set Rules, Continued.	109
Figure 3-37. Lookout Point Dam and Reservoir Operational Summary.	110
Figure 3-38. Lookout Point Dam and Reservoir HEC-ResSim Water Control Diagram.....	111
Figure 3-39. Lookout Point Dam and Reservoir NAA Operation Set Rules.....	114
Figure 3-40. Lookout Point Dam and Reservoir NAA Operation Set Rules, Continued.....	115
Figure 3-41. Lookout Point Dam and Reservoir NAA Operation Set Rules, Continued.....	116
Figure 3-42. Fern Ridge Dam and Reservoir Operational Summary.....	117
Figure 3-43. Fern Ridge Dam and Reservoir HEC-ResSim Water Control Diagram.	117
Figure 3-44. Fern Ridge Dam and Reservoir NAA Operation Set Rules.	120
Figure 3-45. Green Peter Dam and Reservoir Operational Summary.	121
Figure 3-46. Green Peter Dam and Reservoir HEC-ResSim Water Control Diagram.....	122
Figure 3-47. Green Peter Dam and Reservoir NAA Operation Set Rules.....	125
Figure 3-48. Green Peter Dam and Reservoir NAA Operation Set Rules, Continued.....	126
Figure 3-49. Foster Dam and Reservoir Operational Summary.....	127
Figure 3-50. Foster Dam and Reservoir HEC-ResSim Water Control Diagram.	128
Figure 3-51. Foster Dam and Reservoir NAA Operation Set Rules.	130
Figure 3-52. Foster Dam and Reservoir NAA Operation Set Rules, Continued.	131
Figure 3-53. Detroit Dam and Reservoir Operational Summary.	132
Figure 3-54. Detroit Dam and Reservoir HEC-ResSim Water Control Diagram.....	133
Figure 3-55. Detroit Dam and Reservoir NAA Operation Set Rules.....	136
Figure 3-56. Detroit Dam and Reservoir NAA Operation Set Rules, Continued.....	137
Figure 3-57. Detroit Dam and Reservoir NAA Operation Set Rules, Continued.....	138
Figure 3-58. Blue River Dam and Reservoir Validation.....	139
Figure 3-59. Cougar Dam and Reservoir Model Validation.	139
Figure 3-60. Dorena Dam and Reservoir Model Validation.....	140
Figure 3-61. Cottage Grove Dam and Reservoir Model Validation.	140
Figure 3-62. Fall Creek Dam and Reservoir Model Validation.....	141
Figure 3-63. Hills Creek Dam and Reservoir Model Validation.....	141
Figure 3-64. Lookout Point Dam and Reservoir Model Validation.	142
Figure 3-65. Fern Ridge Dam and Reservoir Model Validation.	142
Figure 3-66. Green Peter Dam and Reservoir Model Validation.	143
Figure 3-67. Foster Dam and Reservoir Model Validation.	143
Figure 3-68. Detroit Dam and Reservoir Model Validation.	144
Figure 3-69. Willamette at Albany Model Validation.	144
Figure 3-70. Willamette at Salem Model Validation	145
Figure 4-1. Measure 479, Measure 392, and Station Service Target Below FOS from GPR.....	146
Figure 4-2. Measure 718 Draft Limit at Dorena Dam and Reservoir.....	147

*Willamette Valley System Operations and Maintenance
Environmental Impact Statement*

Figure 4-3. Measure 304 Draft Limit at Lookout Point Dam and Reservoir.	148
Figure 4-4. Measure 723 HD531 Minimum Tributary Flows.	149
Figure 4-5. Measure 30 Minimum Tributary Flow at Green Peter Dam and Reservoir.	151
Figure 4-6. Measure 30 Temperature Minimum Flow at Salem.	151
Figure 4-7. Cougar Dam and Reservoir Spring and Fall Drawdown Target Elevations.....	152
Figure 4-8. Green Peter Dam and Reservoir Fall Drawdown Target Elevation.	153
Figure 4-9. Measure 30b Minimum Tributary Flow at Green Peter Dam and Reservoir.	161
Figure 4-10. Measure 30b Forecast Minimum Flow at Salem.....	161
Figure 4-11. Green Peter Dam and Reservoir Fall Drawdown Target Elevation.	168
Figure 4-12. Foster Dam and Reservoir Interim Operations Target Elevation.	169
Figure 4-13. Cougar Spring and Fall Drawdown Target Elevation.	170
Figure 4-14. Lookout Point Interim Operations Target Elevation.	171
Figure 4-15. M30 Temp Flow Adherence at Salem – Red = fixed temp minimum target and flow, Green = Original temp minimum target and flow.....	177
Figure 5-1. Example Non-exceedance Plot.	179
Figure 5-2. Big Cliff Dam and Reservoir Alternative 1 Non-exceedance Plot.	180
Figure 5-3. Blue River Dam and Reservoir Alternative 1 Non-exceedance Plot.....	181
Figure 5-4. Cottage Grove Dam and Reservoir Alternative 1 Non-exceedance Plot.....	182
Figure 5-5. Cougar Dam and Reservoir Alternative 1 Non-exceedance Plot.....	183
Figure 5-6. Detroit Dam and Reservoir Alternative 1 Non-exceedance Plot.....	184
Figure 5-7. Dexter Dam and Reservoir Alternative 1 Non-exceedance Plot.	185
Figure 5-8. Dorena Dam and Reservoir Alternative 1 Non-exceedance Plot.	186
Figure 5-9. Fall Creek Dam and Reservoir Alternative 1 Non-exceedance Plot.	187
Figure 5-10. Fern Ridge Dam and Reservoir Alternative 1 Non-exceedance Plot.....	188
Figure 5-11. Foster Dam and Reservoir Alternative 1 Non-exceedance Plot.	189
Figure 5-12. Green Peter Dam and Reservoir Alternative 1 Non-exceedance Plot.....	190
Figure 5-13. Hills Creek Dam and Reservoir Alternative 1 Non-exceedance Plot.	191
Figure 5-14. Lookout Point Dam and Reservoir Alternative 1 Non-exceedance Plot.	192
Figure 5-15. Goshen Alternative 1 Non-Exceedance Plot.	193
Figure 5-16. Monroe Alternative 1 Non-exceedance Plot.....	193
Figure 5-17. Vida Alternative 1 Non-exceedance Plot.....	194
Figure 5-18. Jasper Alternative 1 Non-exceedance Plot.....	194
Figure 5-19. Mehama Alternative 1 Non-exceedance Plot.	195
Figure 5-20. Jefferson Alternative 1 Non-exceedance Plot.....	195
Figure 5-21. Waterloo Alternative 1 Non-exceedance Plot.....	196
Figure 5-22. Harrisburg Alternative 1 Non-exceedance Plot.....	196
Figure 5-23. Albany Alternative 1 Non-exceedance Plot.....	197
Figure 5-24. Salem Alternative 1 Non-exceedance Plot.	198
Figure 5-25. Big Cliff Dam and Reservoir Alternative 2A Non-exceedance Plot.....	199
Figure 5-26. Blue River Dam and Reservoir Alternative 2A Non-exceedance Plot.	200
Figure 5-27. Cottage Grove Dam and Reservoir Alternative 2A Non-exceedance Plot.	201

*Willamette Valley System Operations and Maintenance
Environmental Impact Statement*

Figure 5-28. Cougar Dam and Reservoir Alternative 2A Non-exceedance Plot.	202
Figure 5-29. Detroit Dam and Reservoir Alternative 2A Non-exceedance Plot.	203
Figure 5-30. Dexter Dam and Reservoir Alternative 2A Non-exceedance Plot.	204
Figure 5-31. Dorena Dam and Reservoir Alternative 2A Non-exceedance Plot.	205
Figure 5-32. Fall Creek Dam and Reservoir Alternative 2A Non-exceedance Plot.	206
Figure 5-33. Fern Ridge Dam and Reservoir Alternative 2A Non-exceedance Plot.	207
Figure 5-34. Foster Dam and Reservoir Alternative 2A Non-exceedance Plot.	208
Figure 5-35. Green Peter Dam and Reservoir Alternative 2A Non-exceedance Plot.	209
Figure 5-36. Hills Creek Dam and Reservoir Alternative 2A Non-exceedance Plot.	210
Figure 5-37. Lookout Point Dam and Reservoir Alternative 2A Non-exceedance Plot.	211
Figure 5-38. Goshen Alternative 2A Non-exceedance Plot.	212
Figure 5-39. Monroe Alternative 2A Non-exceedance Plot.	212
Figure 5-40. Vida Alternative 2A Non-exceedance Plot.	213
Figure 5-41. Jasper Alternative 2A Non-exceedance Plot.	213
Figure 5-42. Mehama Alternative 2A Non-exceedance Plot.	214
Figure 5-43. Jefferson Alternative 2A Non-exceedance Plot.	214
Figure 5-44. Waterloo Alternative 2A Non-exceedance Plot.	215
Figure 5-45. Harrisburg Alternative 2A Non-exceedance Plot.	215
Figure 5-46. Albany Alternative 2A Non-exceedance Plot.	216
Figure 5-47. Salem Alternative 2A Non-exceedance Plot.	217
Figure 5-48. Big Cliff Dam and Reservoir Alternative 2B Non-exceedance Plot.	218
Figure 5-49. Blue River Dam and Reservoir Alternative 2B Non-exceedance Plot.	219
Figure 5-50. Cottage Grove Dam and Reservoir Alternative 2B Non-exceedance Plot.	220
Figure 5-51. Cougar Dam and Reservoir Alternative 2B Non-exceedance Plot.	221
Figure 5-52. Detroit Dam and Reservoir Alternative 2B Non-exceedance Plot.	222
Figure 5-53. Dexter Dam and Reservoir Alternative 2B Non-exceedance Plot.	223
Figure 5-54. Dorena Dam and Reservoir Alternative 2B Non-exceedance Plot.	224
Figure 5-55. Fall Creek Dam and Reservoir Alternative 2B Non-exceedance Plot.	225
Figure 5-56. Fern Ridge Dam and Reservoir Alternative 2B Non-exceedance Plot.	226
Figure 5-57. Foster Dam and Reservoir Alternative 2B Non-exceedance Plot.	227
Figure 5-58. Green Peter Dam and Reservoir Alternative 2B Non-exceedance Plot.	228
Figure 5-59. Hills Creek Dam and Reservoir Alternative 2B Non-exceedance Plot.	229
Figure 5-60. Lookout Point Dam and Reservoir Alternative 2B Non-exceedance Plot.	230
Figure 5-61. Goshen Alternative 2B Non-exceedance Plot.	231
Figure 5-62. Monroe Alternative 2B Non-exceedance Plot.	231
Figure 5-63. Vida Alternative 2B Non-exceedance Plot.	232
Figure 5-64. Jasper Alternative 2B Non-exceedance Plot.	232
Figure 5-65. Mehama Alternative 2B Non-exceedance Plot.	233
Figure 5-66. Jefferson Alternative 2B Non-exceedance Plot.	233
Figure 5-67. Waterloo Alternative 2B Non-exceedance Plot.	234
Figure 5-68. Harrisburg Alternative 2B Non-exceedance Plot.	234

*Willamette Valley System Operations and Maintenance
Environmental Impact Statement*

Figure 5-69. Albany Alternative 2B Non-exceedance Plot.....	235
Figure 5-70. Salem Alternative 2B Non-exceedance Plot.....	236
Figure 5-71. Big Cliff Dam and Reservoir Alternative 3A Non-exceedance Plot.....	237
Figure 5-72. Blue River Dam and Reservoir Alternative 3A Non-exceedance Plot.	238
Figure 5-73. Cottage Grove Dam and Reservoir Alternative 3A Non-exceedance Plot.	239
Figure 5-74. Cougar Dam and Reservoir Alternative 3A Non-exceedance Plot.	240
Figure 5-75. Detroit Dam and Reservoir Alternative 3A Non-exceedance Plot.	241
Figure 5-76. Dexter Dam and Reservoir Alternative 3A Non-exceedance Plot.....	242
Figure 5-77. Dorena Dam and Reservoir Alternative 3A Non-exceedance Plot.....	243
Figure 5-78. Fall Creek Dam and Reservoir Alternative 3A Non-exceedance Plot.	244
Figure 5-79. Fern Ridge Dam and Reservoir Alternative 3A Non-exceedance Plot.....	245
Figure 5-80. Foster Dam and Reservoir Alternative 3A Non-exceedance Plot.....	246
Figure 5-81. Green Peter Dam and Reservoir Alternative 3A Non-exceedance Plot.	247
Figure 5-82. Hills Creek Dam and Reservoir Alternative 3A Non-exceedance Plot.....	248
Figure 5-83. Lookout Point Dam and Reservoir Alternative 3A Non-exceedance Plot.	249
Figure 5-84. Goshen Alternative 3A Non-exceedance Plot.	250
Figure 5-85. Monroe Alternative 3A Non-exceedance Plot.....	250
Figure 5-86. Vida Alternative 3A Non-exceedance Plot.	251
Figure 5-87. Jasper Alternative 3A Non-exceedance Plot.	251
Figure 5-88. Mehama Alternative 3A Non-exceedance Plot.	252
Figure 5-89. Jefferson Alternative 3A Non-exceedance Plot.....	252
Figure 5-90. Waterloo Alternative 3A Non-exceedance Plot.	253
Figure 5-91. Harrisburg Alternative 3A Non-exceedance Plot.	253
Figure 5-92. Albany Alternative 3A Non-exceedance Plot.	254
Figure 5-93. Salem Alternative 3A Non-exceedance Plot.....	255
Figure 5-94. Big Cliff Dam and Reservoir Alternative 3B Non-exceedance Plot.....	256
Figure 5-95. Blue River Dam and Reservoir Alternative 3B Non-exceedance Plot.....	257
Figure 5-96. Cottage Grove Dam and Reservoir Alternative 3B Non-exceedance Plot.....	258
Figure 5-97. Cougar Dam and Reservoir Alternative 3B Non-exceedance Plot.	259
Figure 5-98. Detroit Dam and Reservoir Alternative 3B Non-exceedance Plot.	260
Figure 5-99. Dexter Dam and Reservoir Alternative 3B Non-exceedance Plot.	261
Figure 5-100. Dorena Dam and Reservoir Alternative 3B Non-exceedance Plot.	262
Figure 5-101. Fall Creek Dam and Reservoir Alternative 3B Non-exceedance Plot.	263
Figure 5-102. Fern Ridge Dam and Reservoir Alternative 3B Non-exceedance Plot.....	264
Figure 5-103. Foster Dam and Reservoir Alternative 3B Non-exceedance Plot.....	265
Figure 5-104. Green Peter Dam and Reservoir Alternative 3B Non-exceedance Plot.	266
Figure 5-105. Hills Creek Dam and Reservoir Alternative 3B Non-exceedance Plot.....	267
Figure 5-106. Lookout Point Dam and Reservoir Alternative 3B Non-exceedance Plot.	268
Figure 5-107. Goshen Alternative 3B Non-exceedance Plot.	269
Figure 5-108. Monroe Alternative 3B Non-exceedance Plot.....	269
Figure 5-109. Vida Alternative 3B Non-exceedance Plot.....	270

*Willamette Valley System Operations and Maintenance
Environmental Impact Statement*

Figure 5-110. Jasper Alternative 3B Non-exceedance Plot.	270
Figure 5-111. Mehama Alternative 3B Non-exceedance Plot.	271
Figure 5-112. Jefferson Alternative 3B Non-exceedance Plot.	271
Figure 5-113. Waterloo Alternative 3B Non-exceedance Plot.	272
Figure 5-114. Harrisburg Alternative 3B Non-exceedance Plot.	272
Figure 5-115. Albany Alternative 3B Non-exceedance Plot.	273
Figure 5-116. Salem Alternative 3B Non-exceedance Plot.	274
Figure 5-117. Big Cliff Dam and Reservoir Alternative 4 Non-exceedance Plot.	275
Figure 5-118. Blue River Dam and Reservoir Alternative 4 Non-exceedance Plot.	276
Figure 5-119. Cottage Grove Dam and Reservoir Alternative 4 Non-exceedance Plot.	277
Figure 5-120. Cougar Dam and Reservoir Alternative 4 Non-exceedance Plot.	278
Figure 5-121. Detroit Dam and Reservoir Alternative 4 Non-exceedance Plot.	279
Figure 5-122. Dexter Dam and Reservoir Alternative 4 Non-exceedance Plot.	280
Figure 5-123. Dorena Dam and Reservoir Alternative 4 Non-exceedance Plot.	281
Figure 5-124. Fall Creek Dam and Reservoir Alternative 4 Non-exceedance Plot.	282
Figure 5-125. Fern Ridge Dam and Reservoir Alternative 4 Non-exceedance Plot.	283
Figure 5-126. Foster Dam and Reservoir Alternative 4 Non-exceedance Plot.	284
Figure 5-127. Green Peter Dam and Reservoir Alternative 4 Non-exceedance Plot.	285
Figure 5-128. Hills Creek Dam and Reservoir Alternative 4 Non-exceedance Plot.	286
Figure 5-129. Lookout Point Dam and Reservoir Alternative 4 Non-exceedance Plot.	287
Figure 5-130. Goshen Alternative 4 Non-exceedance Plot.	288
Figure 5-131. Monroe Alternative 4 Non-exceedance Plot.	288
Figure 5-132. Vida Alternative 4 Non-exceedance Plot.	289
Figure 5-133. Jasper Alternative 4 Non-exceedance Plot.	289
Figure 5-134. Mehama Alternative 4 Non-exceedance Plot.	290
Figure 5-135. Jefferson Alternative 4 Non-exceedance Plot.	290
Figure 5-136. Waterloo Alternative 4 Non-exceedance Plot.	291
Figure 5-137. Harrisburg Alternative 4 Non-exceedance Plot.	291
Figure 5-138. Albany Alternative 4 Non-exceedance Plot.	292
Figure 5-139. Salem Alternative 4 Non-exceedance Plot.	293
Figure 5-140. Big Cliff Dam and Reservoir Alternative 5 Non-exceedance Plot.	294
Figure 5-141. Blue River Dam and Reservoir Alternative 5 Non-exceedance Plot.	295
Figure 5-142. Cottage Grove Dam and Reservoir Alternative 5 Non-exceedance Plot.	296
Figure 5-143. Cougar Dam and Reservoir Alternative 5 Non-exceedance Plot.	297
Figure 5-144. Detroit Dam and Reservoir Alternative 5 Non-exceedance Plot.	298
Figure 5-145. Dexter Dam and Reservoir Alternative 5 Non-exceedance Plot.	299
Figure 5-146. Dorena Dam and Reservoir Alternative 5 Non-exceedance Plot.	300
Figure 5-147. Fall Creek Dam and Reservoir Alternative 5 Non-exceedance Plot.	301
Figure 5-148. Fern Ridge Dam and Reservoir Alternative 5 Non-exceedance Plot.	302
Figure 5-149. Foster Dam and Reservoir Alternative 5 Non-exceedance Plot.	303
Figure 5-150. Green Peter Dam and Reservoir Alternative 5 Non-exceedance Plot.	304

*Willamette Valley System Operations and Maintenance
Environmental Impact Statement*

Figure 5-151. Hills Creek Dam and Reservoir Alternative 5 Non-exceedance Plot.	305
Figure 5-152. Lookout Point Dam and Reservoir Alternative 5 Non-exceedance Plot.	306
Figure 5-153. Goshen Alternative 5 Non-exceedance Plot.	307
Figure 5-154. Monroe Alternative 5 Non-exceedance Plot.....	307
Figure 5-155. Vida Alternative 5 Non-exceedance Plot.....	308
Figure 5-156. Jasper Alternative 5 Non-exceedance Plot.....	308
Figure 5-157. Mehama Alternative 5 Non-exceedance Plot.	309
Figure 5-158. Jefferson Alternative 5 Non-exceedance Plot.	309
Figure 5-159. Waterloo Alternative 5 Non-exceedance Plot.....	310
Figure 5-160. Harrisburg Alternative 5 Non-exceedance Plot.....	310
Figure 5-161. Albany Alternative 5 Non-exceedance Plot.....	311
Figure 5-162. Salem Alternative 5 Non-exceedance Plot.	312
Figure 5-163. Big Cliff Dam and Reservoir Interim Operations Non-exceedance Plot.	354
Figure 5-164. Blue River Dam and Reservoir Interim Operations Non-exceedance Plot.....	355
Figure 5-165. Cottage Grove Dam and Reservoir Interim Operations Non-exceedance Plot....	356
Figure 5-166. Cougar Dam and Reservoir Interim Operations Non-exceedance Plot.....	357
Figure 5-167. Detroit Dam and Reservoir Interim Operations Non-exceedance Plot.....	358
Figure 5-168. Dexter Dam and Reservoir Interim Operations Non-exceedance Plot.	359
Figure 5-169. Dorena Dam and Reservoir Interim Operations Non-exceedance Plot.	360
Figure 5-170. Fall Creek Dam and Reservoir Interim Operations Non-exceedance Plot.	361
Figure 5-171. Fern Ridge Dam and Reservoir Interim Operations Non-exceedance Plot.....	362
Figure 5-172. Foster Dam and Reservoir Interim Operations Non-exceedance Plot.....	363
Figure 5-173. Green Peter Dam and Reservoir Interim Operations Non-exceedance Plot.	364
Figure 5-174. Hills Creek Dam and Reservoir Interim Operations Non-exceedance Plot.	365
Figure 5-175. Lookout Point Dam and Reservoir Interim Operations Non-exceedance Plot. ...	366
Figure 5-176. Goshen Interim Operations Non-exceedance Plot.....	367
Figure 5-177. Monroe Interim Operations Non-exceedance Plot.....	367
Figure 5-178. Vida Interim Operations Non-exceedance Plot.....	368
Figure 5-179. Jasper Interim Operations Non-exceedance Plot.....	368
Figure 5-180. Mehama Interim Operations Non-exceedance Plot.	369
Figure 5-181. Jefferson Interim Operations Non-exceedance Plot.	369
Figure 5-182. Waterloo Interim Operations Non-exceedance Plot.....	370
Figure 5-183. Harrisburg Interim Operations Non-exceedance Plot.....	370
Figure 5-184. Albany Interim Operations Non-exceedance Plot.....	371
Figure 5-185. Salem Interim Operations Non-exceedance Plot.	372
Figure 5-186. Big Cliff Dam and Reservoir Alternatives 5/2B Non-exceedance Plot.....	374
Figure 5-187. Blue River Dam and Reservoir Alternatives 5/2B Non-exceedance Plot.	375
Figure 5-188. Cottage Grove Dam and Reservoir Alternatives 5/2B Non-exceedance Plot.	376
Figure 5-189. Cougar Dam and Reservoir Alternatives 5/2B Non-exceedance Plot.	377
Figure 5-190. Detroit Dam and Reservoir Alternatives 5/2B Non-exceedance Plot.	378
Figure 5-191. Dexter Dam and Reservoir Alternatives 5/2B Non-exceedance Plot.....	379

*Willamette Valley System Operations and Maintenance
Environmental Impact Statement*

Figure 5-192. Dorena Dam and Reservoir Alternatives 5/2B Non-exceedance Plot.....	380
Figure 5-193. Fall Creek Dam and Reservoir Alternatives 5/2B Non-exceedance Plot.....	381
Figure 5-194. Fern Ridge Dam and Reservoir Alternatives 5/2B Non-exceedance Plot.....	382
Figure 5-195. Foster Dam and Reservoir Alternatives 5/2B Non-exceedance Plot.....	383
Figure 5-196. Green Peter Dam and Reservoir Alternatives 5/2B Non-exceedance Plot.....	384
Figure 5-197. Hills Creek Dam and Reservoir Alternatives 5/2B Non-exceedance Plot.....	385
Figure 5-198. Lookout Point Dam and Reservoir Alternatives 5/2B Non-exceedance Plot.....	386
Figure 5-199. Goshen Alternatives 5/2B Non-exceedance Plot.....	387
Figure 5-200. Monroe Alternatives 5/2B Non-exceedance Plot.....	388
Figure 5-201. Vida Alternatives 5/2B Non-exceedance Plot.....	389
Figure 5-202. Jasper Alternatives 5/2B Non-exceedance Plot.....	389
Figure 5-203. Mehama Alternatives 5/2B Non-exceedance Plot.....	390
Figure 5-204. Jefferson Alternatives 5/2B Non-exceedance Plot.....	390
Figure 5-205. Waterloo Alternatives 5/2B Non-exceedance Plot.....	391
Figure 5-206. Harrisburg Alternatives 5/2B Non-exceedance Plot.....	391
Figure 5-207. Albany Alternatives 5/2B Non-exceedance Plot.....	392
Figure 5-208. Salem Alternatives 5/2B Non-exceedance Plot.....	393
Figure 5-209. Blue River Dam and Reservoir Alternatives 5/2B WY 2009–2019 Plot.....	394
Figure 5-210. Cottage Grove Dam and Reservoir Alternatives 5/2B WY 2009–2019 Plot.....	395
Figure 5-211. Cougar Dam and Reservoir Alternatives 5/2B WY 2009–2019 Plot.....	396
Figure 5-212. Detroit Dam and Reservoir Alternatives 5/2B WY 2009–2019 Plot.....	397
Figure 5-213. Dorena Dam and Reservoir Alternatives 5/2B WY 2009–2019 Plot.....	398
Figure 5-214. Fall Creek Dam and Reservoir Alternatives 5/2B WY 2009–2019 Plot.....	399
Figure 5-215. Fern Ridge Dam and Reservoir Alternatives 5/2B WY 2009–2019 Plot.....	400
Figure 5-216. Foster Dam and Reservoir Alternatives 5/2B WY 2009–2019 Plot.....	401
Figure 5-217. Green Peter Dam and Reservoir Alternatives 5/2B WY 2009–2019 Plot.....	402
Figure 5-218. Hills Creek Dam and Reservoir Alternatives 5/2B WY 2009–2019 Plot.....	403
Figure 5-219. Lookout Point Dam and Reservoir Alternatives 5/2B WY 2009–2019 Plot.....	404
Figure 5-220. Goshen Alternatives 5/2B WY 2009–2019 Plot.....	405
Figure 5-221. Monroe Alternatives 5/2B WY 2009–2019 Plot.....	406
Figure 5-222. Vida Alternatives 5/2B WY 2009–2019 Plot.....	407
Figure 5-223. Jasper Alternatives 5/2B WY 2009–2019 Plot.....	408
Figure 5-224. Jefferson Alternatives 5/2B WY 2009–2019 Plot.....	409
Figure 5-225. Waterloo Alternatives 5/2B WY 2009–2019 Plot.....	410
Figure 5-226. Harrisburg Alternatives 5/2B WY 2009–2019 Plot.....	411
Figure 5-227. Albany Alternatives 5/2B WY 2009–2019 Plot.....	412
Figure 5-228. Salem Alternatives 5/2B WY 2009–2019 Plot.....	413
Figure 6-1. Blue River Dam and Reservoir Climate Change Projections.....	429
Figure 6-2. Cougar Dam and Reservoir Climate Change Projections.....	430
Figure 6-3. Cottage Grove Dam and Reservoir Climate Change Projections.....	431
Figure 6-4. Detroit Dam and Reservoir Climate Change Projections.....	432

*Willamette Valley System Operations and Maintenance
Environmental Impact Statement*

Figure 6-5. Dorena Dam and Reservoir Climate Change Projections.	433
Figure 6-6. Falls Creek Dam and Reservoir Climate Change Projections.....	434
Figure 6-7. Fern Ridge Dam and Reservoir Climate Change Projections.....	435
Figure 6-8. Green Peter Dam and Reservoir Climate Change Projections.	436
Figure 6-9. Hills Creek Dam and Reservoir Climate Change Projections.....	437
Figure 6-10. Lookout Point Dam and Reservoir Climate Change Projections.	438
Figure 6-11. Albany Climate Change Projections.....	439
Figure 6-12. Salem Climate Change Projections.	440
Figure 7-1. Alternative (a) and No-action (b) No Drawdown Zones.....	442
Figure 7-2. Blue River Dam and Reservoir No-action and Alternative Operations Pool Elevations in Insufficient and Deficit Water Years.....	445
Figure 7-3. Cougar Dam and Reservoir No-action and Alternative Operations Pool Elevations in Insufficient and Deficit Water Years.....	446
Figure 7-4. Cottage Grove Dam and Reservoir No-action and Alternative Operations Pool Elevations in Insufficient and Deficit Water Years.	446
Figure 7-5. Detroit Dam and Reservoir No-action and Alternative Operations Pool Elevations in Insufficient and Deficit Water Years.....	447
Figure 7-6. Dorena Dam and Reservoir No-action and Alternative Operations Pool Elevations in Insufficient and Deficit Water Years.....	448
Figure 7-7. Fall Creek No-action and Alternative Operations Pool Elevations in Insufficient and Deficit Water Years.....	448
Figure 7-8. Fern Ridge Dam and Reservoir No-action and Alternative Operations Pool Elevations in Insufficient and Deficit Water Years.....	449
Figure 7-9. Green Peter Dam and Reservoir No-action and Alternative Operations Pool Elevations in Insufficient and Deficit Water Years.	450
Figure 7-10. Hills Creek Dam and Reservoir No-action and Alternative Operations Pool Elevations in Insufficient and Deficit Water Years.	450
Figure 7-11. Lookout Point Dam and Reservoir No-action and Alternative Operations Pool Elevations in Insufficient and Deficit Water Years.	451
Figure 8-1. Secondary Flood Storage at Willamette Valley Reservoirs.	452
Figure 8-2. Willamette at Harrisburg, December 1964.	455
Figure 8-3. South Santiam at Waterloo December 1964.....	455
Figure 8-4. Willamette at Salem, December 1964.....	456
Figure 8-5. Green Peter Reservoir, February 1996.	456
Figure 8-6. South Santiam at Waterloo, February 1996.	457
Figure 8-7. Blue River Dam and Reservoir, December 1964.	457
Figure 8-8. Cougar Dam and Reservoir, December 1964.	458
Figure 8-9. Detroit Dam and Reservoir, December 1964.	458
Figure 8-10. Green Peter Dam and Reservoir, December 1964.	459
Figure 8-11. Hills Creek Dam and Reservoir, December 1964.....	459
Figure 8-12. Lookout Point Dam and Reservoir, December 1964.	460
Figure 8-13. Harrisburg, December 1964.	460

*Willamette Valley System Operations and Maintenance
Environmental Impact Statement*

Figure 8-14. Jasper, December 1964. 461

Figure 8-15. Jefferson, December 1964..... 461

Figure 8-16. Mehama, December 1964. 462

Figure 8-17. Salem, December 1964..... 462

Figure 8-18. Vida, December 1964. 463

Figure 8-19. Waterloo, December 1964. 463

Figure 9-1. Secondary Flood Storage at Willamette Valley Reservoirs. 464

Figure 9-2. Refill Scenarios – Green = Baseline, Blue = Alternative..... 489

Figure 10-1. Lookout Point Dam and Reservoir Water Control Diagram. 491

Figure 10-2. Fall Creek Dam and Reservoir Water Control Diagram. 492

Figure 10-3. Fern Ridge Dam and Reservoir Water Control Diagram. 492

Figure 10-4. Hills Creek Dam and Reservoir Water Control Diagram..... 493

Figure 10-5. Blue River Dam and Reservoir Water Control Diagram. 493

Figure 10-6. Green Peter Dam and Reservoir Water Control Diagram. 494

Figure 10-7. Cottage Grove Dam and Reservoir Water Control Diagram. 494

Figure 10-8. Dorena Dam and Reservoir Water Control Diagram..... 495

Figure 10-9. Foster Dam and Reservoir Water Control Diagram..... 495

Figure 10-10. Cougar Dam and Reservoir Water Control Diagram. 496

Figure 10-11. Detroit Dam and Reservoir Water Control Diagram. 496

Figure 10-12. Big Cliff Dam and Reservoir Water Control Diagram..... 497

Figure 10-13. Dexter Dam and Reservoir Water Control Diagram. 497

Figure 11-1. Coast Fork of the Willamette River at Goshen, OR. Flows across the Water Year. 498

Figure 11-2. Long Tom River at Monroe, OR. Flows across the Water Year. 498

Figure 11-3. McKenzie River at Vida, OR. Flows across the Water Year. 499

Figure 11-4. North Santiam River at Mehama, OR. Flows across the Water Year. 499

Figure 11-5. South Santiam River at Waterloo, OR. Flows across the Water Year. 500

Figure 11-6. Santiam River at Jefferson, OR. Flows across the Water Year. 500

Figure 11-7. Willamette River at Harrisburg, OR. Flows across the Water Year. 501

Figure 11-8. Willamette River at Salem, OR. Flows across the Water Year. 501

Figure 11-9. Blue River Reservoir Water Surface Elevation across 2011, 2015, and 2016. 502

Figure 11-10. Cougar Reservoir Water Surface Elevation across 2011, 2015, and 2016. 502

Figure 11-11. Cottage Grove Reservoir Water Surface Elevation across 2011, 2015, and 2016.
..... 503

Figure 11-12. Dorena Reservoir Water Surface Elevation across 2011, 2015, and 2016..... 503

Figure 11-13. Fall Creek Reservoir Water Surface Elevation across 2011, 2015, and 2016..... 504

Figure 11-14. Hills Creek Reservoir Water Surface Elevation across 2011, 2015, and 2016..... 504

Figure 11-15. Fern Ridge Reservoir Water Surface Elevation across 2011, 2015, and 2016. 505

Figure 11-16. Foster Reservoir Water Surface Elevation across 2011, 2015, and 2016. 505

*Willamette Valley System Operations and Maintenance
Environmental Impact Statement*

1 INTRODUCTION

This technical appendix is designed to provide information on the development of the hydrologic model for the Willamette Valley System EIS. This includes technical details on the development of the input hydrologic dataset, the HEC-ResSim reservoir regulation model, related climate change analysis, and additional figures not included in the main report.

2 INFLOW DATASET

2.1 Overview

The HEC-ResSim model is used to simulate the period of record to assess hydrologic impacts across the WVS. However, the HEC-ResSim model needs to account for many hydrologic input datasets, including inflows, evaporation, and irrigation depletions. Prior datasets only extended to 2009. There have been several notable events since 2009, including an extremely dry year in 2015 and an unusually late flood in April 2019. As part of the hydrologic modeling for the WVS, the Corps selected a dataset for use up until 2009 and extended the dataset through water year 2019.

2.2 Assumptions

Only daily average datasets are required. Datasets with a smaller time step (e.g., hourly) are useful for a model that is specifically focused on flood risk management (FRM), but the computational and data demands are much larger for a smaller time step. Because the Willamette Valley System EIS is a more general-purpose model where FRM is just one impact area among many, a daily average dataset is developed and applied.

Willamette Falls at Oregon City is the downstream end of the model. Salem is the furthest downstream point at which reservoirs actively operate. The hydrologic inputs between Salem and Oregon City are included in the reservoir model, but they have no impact on the upstream reservoir operations.

2.3 Existing Datasets and Information

The Willamette River Basin has been studied extensively through the years, and many inflow datasets already exist with inflow data.

2.3.1 Existing Inflow Datasets

The Willamette Flood Insurance Study (FIS) dataset (USACE 2011a; USACE 2013) was developed for the Willamette River Basin with the specific purpose of modeling flood conditions accurately. Inflows are developed at all locations required for reservoir operations. Daily average and hourly datasets are developed from 1935–2009. Significant QC efforts were taken for the winter season, while less scrutiny was given to the summer season. Irrigation and

*Willamette Valley System Operations and Maintenance
Environmental Impact Statement*

evaporation were not addressed consistently in this dataset. The datasets extend downstream to Salem.

The 2010 Modified Flows (BPA 2011) was developed jointly by three Federal agencies (Bonneville Power Administration, the Corps, and the Bureau of Reclamation) and builds on datasets developed roughly every decade for the whole Columbia Basin. The dataset spans September 1928 to October 2008 with daily average flow values downstream to Oregon City (Willamette Falls). The current level of irrigation in the 2010 modified flows is defined from the year 2008, which is the last year of the dataset. The adjustment includes estimates for evaporation and return flows as well. The Modified Flow dataset generally only includes estimates at dam sites and a few other key locations in the Willamette River Basin, such as Salem and Albany. It does not include flow estimates at many other control points in the basin, such as Jasper, Mehama, and Jefferson. These control point locations are used during FRM operations at upstream reservoirs. Therefore, the 2010 Modified Flow dataset cannot be used directly to model FRM operations in the Willamette Valley. To summarize this flow set, the modified flows are defined as the historical streamflow that would have been observed without reservoir regulation and with all years adjusted to the same level of irrigation depletions (2008). Therefore, changes in irrigation practices have been accounted for across all years of the dataset. The only locations with irrigation depletions identified in the Willamette Valley are upstream of Fern Ridge Dam and Reservoir, Albany, Salem, and Oregon City. After the EIS hydrologic dataset was developed, the 2020 Modified Flow Dataset was published. The 2020 Modified Flows were not used in the EIS.

The 2010 No Regulation, No Irrigation (NRNI) dataset (BPA 2017) uses the base data from the 2010 Modified Flow work to produce a naturalized dataset without the effects of reservoir regulation and irrigation. The results for the Willamette River Basin are very similar to the Modified Flow dataset—only the irrigation effects are removed (USGS 2018).

Every year, Portland District helps provide a report to Congress showing the damages prevented by Willamette Valley Reservoirs. Part of that effort involves developing the Annual Flood Damage Reduction (AFDR) dataset for the largest flood event for the year. The AFDR analysis uses an automated process to calculate flows with and without reservoirs for the flood event. Whole water years are not available—only a short time window with the highest flow event.

As part of routine data collection, Portland District calculates inflows for projects using the measured outflow and change in reservoir storage, stored in USACE Dataquery. Prior to 2012, this database was known as the Columbia Database (CDB), and data could be accessed via Dataquery 1.0. SHEF codes were used to identify the data. For instance, “QIDRXZZAZD” is a SHEF code for Cougar (CGR) Reservoir inflow. This data source was used when constructing the 2010 modified flows and FIS flows. In 2012, Portland District transitioned to the Corps Water Management System (CWMS) to collect data. Data from CWMS is available via Dataquery 2.0 (also known as DBQuery). The calculation methods for project inflow were slightly modified at

*Willamette Valley System Operations and Maintenance
Environmental Impact Statement*

this time. CWMS pathnames are used to identify data in this database, such as “CGR.Flow-In.Ave.~1Day.1Day.CBT-REV”.

2.3.2 Existing Evaporation Datasets

Evaporation data is most commonly reported in the form of pan evaporation rates (USGS 2010). As is implied by the name, the reported values are measured evaporation from a pan in inches. Evaporation rates from a small pan are larger than those from a larger body of water due to an oasis effect. To estimate evaporation from lake surfaces, pan evaporation rates are typically multiplied by a constant of 0.70, but studies show that actual coefficients can range from 0.64 to 0.88 (NOAA 1982). Evaporation is a function of several meteorological variables which may be difficult to measure, and so pan evaporation is considered one of the most direct methods for measuring evaporation rates. Evaporation volume from a reservoir is a function of evaporation rates and surface area, which varies with reservoir elevation.

WEST consultants estimated monthly average evaporation rates at Willamette Valley reservoirs in 2011 (WEST 2011). The data source used in the WEST report was pan evaporation measurements reported by the Western Regional Climate Center (WRCC) at Cottage Grove, Detroit, Dorena, Fern Ridge, and Lookout Point Reservoirs (WRCC 2020). West multiplied pan evaporation rates by 0.75 to estimate the evaporation more closely from lake surfaces. For the reservoirs that did not have evaporation data, evaporation from the closest reservoir or the reservoir with the most similar climate was used. Precipitation data gathered from WRCC was then incorporated into net evaporation resulting in negative evaporation rates in some months (WEST 2011). The values provided by WEST are currently used in several HEC-ResSim watersheds. These values are presented in Table 2-1.

Table 2-1. WEST Monthly Evaporation Rates (inches).

Project	JAN	FEB	MAR	APR	MAY	JUN	JUL	AUG	SEP	OCT	NOV	DEC
HCR (LOP)	-6.24	-3.03	-2.62	-0.77	1.29	3.77	7.09	5.96	2.81	-1.42	-5.65	-6.94
FAL (LOP)	-6.24	-3.03	-2.62	-0.77	1.29	3.77	7.09	5.96	2.81	-1.42	-5.65	-6.94
LOP	-6.24	-3.03	-2.62	-0.77	1.29	3.77	7.09	5.96	2.81	-1.42	-5.65	-6.94
DEX (DET)	-12.79	-8.83	-7.95	-4.66	-0.95	2.51	6.86	5.26	1.17	-4.87	-12.67	-14.14
GPR (DET)	-12.79	-8.83	-7.95	-4.66	-0.95	2.51	6.86	5.26	1.17	-4.87	-12.67	-14.14
FOS (DET)	-12.79	-8.83	-7.95	-4.66	-0.95	2.51	6.86	5.26	1.17	-4.87	-12.67	-14.14
DET	-12.79	-8.83	-7.95	-4.66	-0.95	2.51	6.86	5.26	1.17	-4.87	-12.67	-14.14
COT	-7.07	-4.55	-3.79	-1.49	0.53	2.53	5.3	4.2	1.83	-2.58	-6.61	-7.48
DOR	-6.67	-4.07	-3.28	-0.9	1.81	4.32	7.67	6.27	3.01	-1.77	-6.82	-7.32
FRN	-6.1	-4.19	-2.41	0.67	3.25	5.01	7.75	6.52	3.61	-0.89	-5.94	-6.91
CGR (LOP)	-6.24	-3.03	-2.62	-0.77	1.29	3.77	7.09	5.96	2.81	-1.42	-5.65	-6.94
BLU (LOP)	-6.24	-3.03	-2.62	-0.77	1.29	3.77	7.09	5.96	2.81	-1.42	-5.65	-6.94

WRCC provided the Corps with the base data used to derive the evaporation coefficients listed on their website (WRCC 2020), in the form of monthly cumulative values as shown in Table 2-2. While the Corps does have some evaporation data in the CWMS database, there are many

*Willamette Valley System Operations and Maintenance
Environmental Impact Statement*

more years of record available from WRCC than were found on the Corps CWMS database. Neither the WRCC data nor from the Corps CWMS database have documentation associated with it, so it is unclear how either was obtained. Table 2-3 indicates the period of record (POR) for the WRCC and Corps evaporation data. For time periods of overlapping data, the WRCC and CWMS estimates are quite similar, suggesting they may be based off the same pan evaporation site. Estimates are typically within a half-inch of each other. It is possible that one of the datasets underwent additional quality control, while the other dataset used more provisional data. There is not enough information to explain the differences, but they appear to be small.

Table 2-2. WRCC Monthly Pan Evaporation Rates (inches) Multiplied by 0.70.

Project	JAN	FEB	MAR	APR	MAY	JUN	JUL	AUG	SEP	OCT	NOV	DEC
COTTAGE GROVE	0.00	0.89	1.51	2.15	3.19	3.92	5.43	4.69	3.13	1.44	0.57	0.00
DETROIT	0.13	0.81	1.18	1.76	3.07	4.13	5.38	4.65	2.97	1.44	0.62	0.32
DORENA	0.00	0.71	1.36	2.07	3.49	4.28	5.73	5.01	3.26	1.41	0.00	0.00
FERN RIDGE	0.27	0.55	1.34	2.22	3.52	4.35	5.68	4.96	3.33	1.55	0.47	0.24
LOOKOUT POINT	0.00	1.23	1.60	2.17	3.27	4.04	5.38	4.82	3.12	1.37	0.71	0.00

Table 2-3. Evaporation Datasets Period of Record.

Project	USACE (CWMS database)	WRCC
COT	1975-1978, 1990-1994	1948-1978
DET	1974-1978, 1990-1992	1955-1993
DOR	1975-1978, 1990	1967-1978
FRN	1975-2005	1948-2007
LOP	1985-2006	1956-2006

The previously discussed evaporation datasets report average monthly evaporation rates. The volumetric evaporation from a reservoir in each month only varies based on reservoir elevation (and therefore surface area). Average monthly evaporation rates assume average monthly climate variables. The evaporation in a given month of a year is a function of many meteorologic variables including air temperature, solar radiation, wind, and humidity.

Figure 2-1 shows regressions of pan evaporation as a function of maximum daily temperatures averaged over the month at Salem at the reservoirs with available Corps pan evaporation data. There is insufficient data to perform regressions with other meteorologic variables. A strong correlation between monthly project evaporation and temperature at Salem is observed with correlation coefficients ranging between 0.58 and 0.77.

*Willamette Valley System Operations and Maintenance
Environmental Impact Statement*

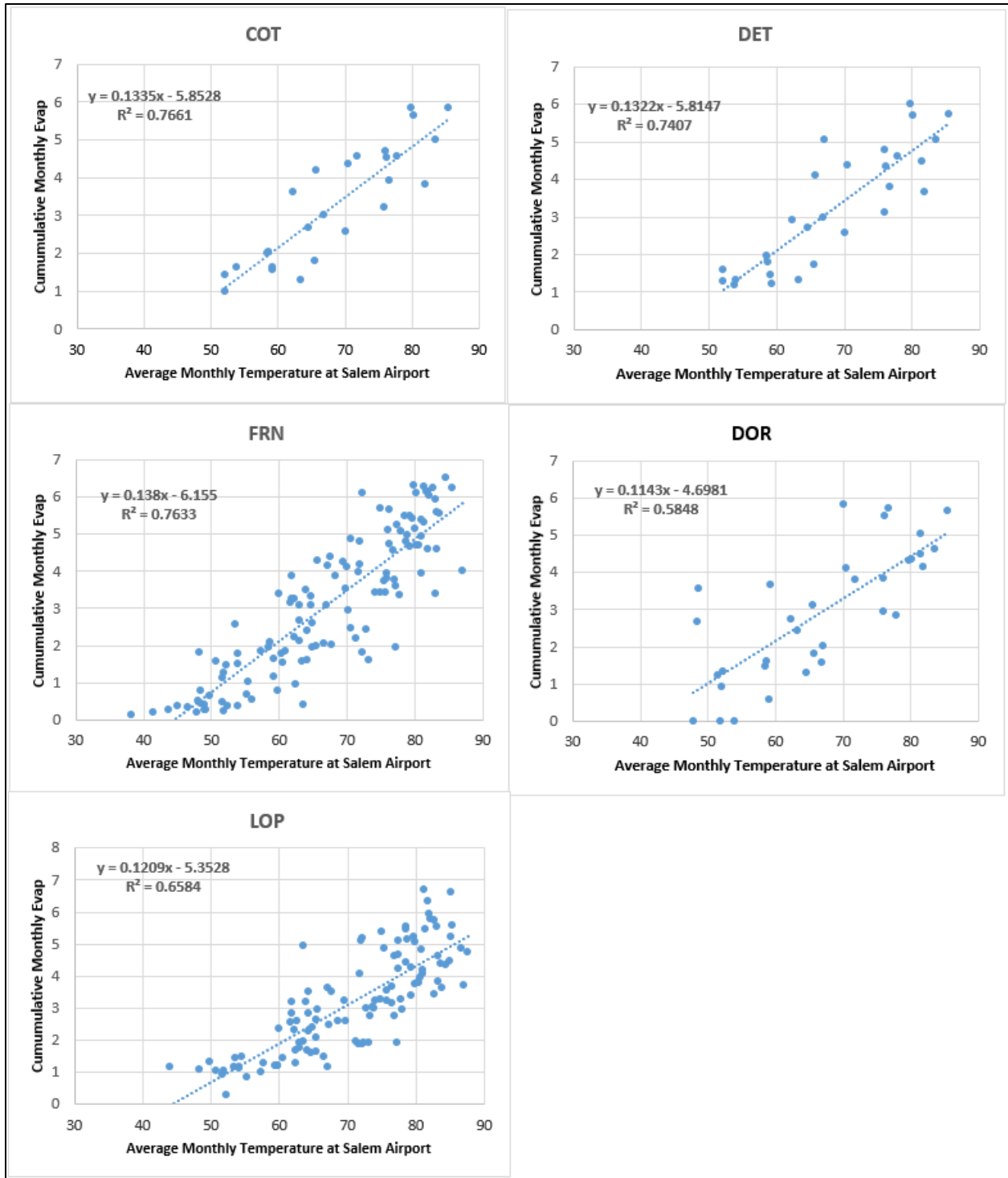

Figure 2-1. Monthly Pan Evaporation as a Function of Maximum Daily Temperatures Averaged over the Month at Salem.

Table 2-4 applies the WRCC pan evaporation rates corrected with the NOAA recommended constant of 0.7 and calculates the resulting evaporation volume assuming that reservoir elevations follow the Congressionally mandated rule curves. For reservoirs without at-site pan

*Willamette Valley System Operations and Maintenance
Environmental Impact Statement*

evaporation measurements, evaporation rates from the reservoir with the most similar climate was used, consistent with the approach taken in Table 2-1 (WEST 2011). The resulting conservation season evaporation is compared with the storage at full conservation pool to identify the relative impact of evaporation on conservation storage. Fern Ridge Reservoir exhibits the largest volume of evaporative losses in both relative and absolute terms, more than twice any other reservoir. Evaporative losses at Fern Ridge Reservoir can exceed inflows in some months.

Table 2-4. Estimated Conservation Season Evaporation.

Reservoir	Maximum Conservation Storage (KAF)	Estimated June 1 - Sept 1 Evaporation (KAF)	% Conservation Storage Reduction	Average Daily June 1 - Sep 1 Evaporation (CFS)
Blue River	79	1.5	1.8%	6
Cottage Grove	29	1.6	5.6%	7
Cougar	137	1.9	1.4%	8
Detroit	281	5.0	1.8%	21
Dorena	65	2.5	3.8%	10
Fall Creek	107	2.6	2.4%	11
Fern Ridge	95	13.5	14.3%	56
Foster	25	1.8	7.2%	7
Green Peter	250	1.9	2.3%	23
Hills Creek	195	3.9	2.0%	16
Lookout Point	325	6.3	1.9%	26

The 2010 Modified Flow hydrologic dataset includes a coarse correction for evaporation, but this is only performed for Lookout Point and Fern Ridge Reservoirs. For both Fern Ridge and Lookout Point Reservoirs, the estimate of evaporation is a flat 10 cfs per day for the months of July through September. Negative 10 cfs is applied for evaporation in May for Fern Ridge Reservoir, and negative 10 cfs is applied in April for Lookout Point Reservoir. All other periods have no assumed evaporation. These estimates do not take into account changes in reservoir surface area or climate. The 2010 Modified Flow data set was created without consideration for what surface evaporation rates would be used in HEC-ResSim and other models. Estimated conservation season evaporation calculated from WRCC coefficients and guide curve project elevations presented in Table 2-4 suggests the 2010 Modified Flow dataset most significantly underestimates evaporation at Fern Ridge Reservoir.

2.3.3 Existing Irrigation Datasets

Historic and current Irrigation withdrawals and return flows are not well documented in the Willamette River Basin. The most rigorous investigation of irrigation withdrawals and return

*Willamette Valley System Operations and Maintenance
Environmental Impact Statement*

flows is believed to have been conducted while creating the 2010 Modified Flows dataset. This study concluded that most of the irrigation has historically and is currently located along the main stem of the Willamette River between Eugene and Oregon City. Estimates of historical crop acreage by type and irrigation methods used were compared with 2008 conditions and the difference between the two calculated for each year in the POR. These values were calculated for areas above Fern Ridge Dam and Reservoir, Albany, Salem, and Oregon City in the Willamette Valley and are presented in Figure 2-2, Figure 2-3, and Figure 2-4. Depletions for locations on the mainstem Willamette River were assumed to be a percentage of total Willamette Valley estimates: 25 percent at Albany, 40 percent at Salem, and 93 percent at Oregon City. Figure 2-3 and Figure 2-4 show that irrigation levels at Salem and Albany are assumed to be about the same in the year 1970 and the year 2008. Depletions peaked around 1980. Agricultural water conservation from about 1980 to the present accounts for the change in irrigation depletions.

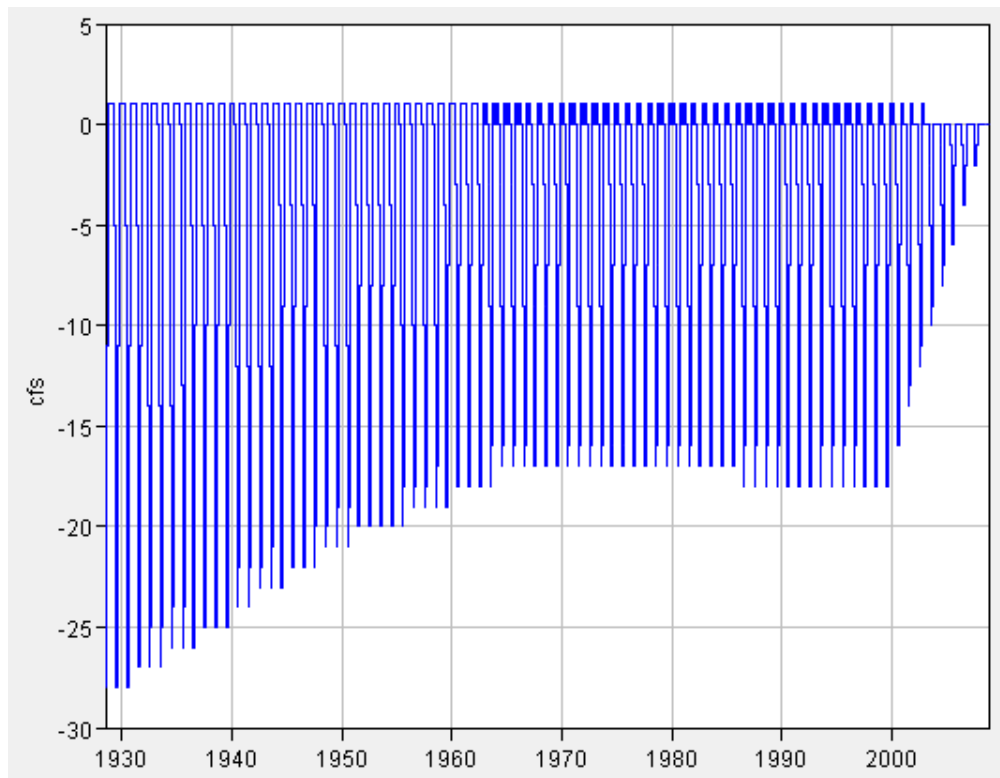

Figure 2-2. Historical Minus 2008 Irrigation Withdrawals and Return Flows above Fern Ridge Dam and Reservoir.

*Willamette Valley System Operations and Maintenance
Environmental Impact Statement*

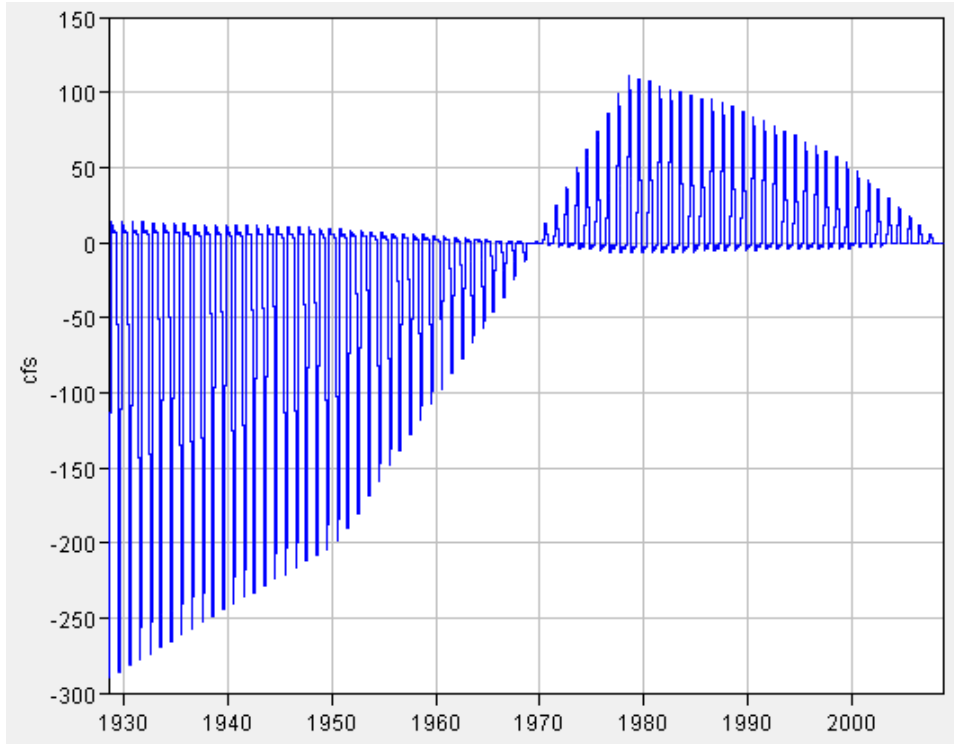

Figure 2-3. Historical Minus 2008 Irrigation Withdrawals and Return Flows above Albany (not including above Fern Ridge Dam and Reservoir).

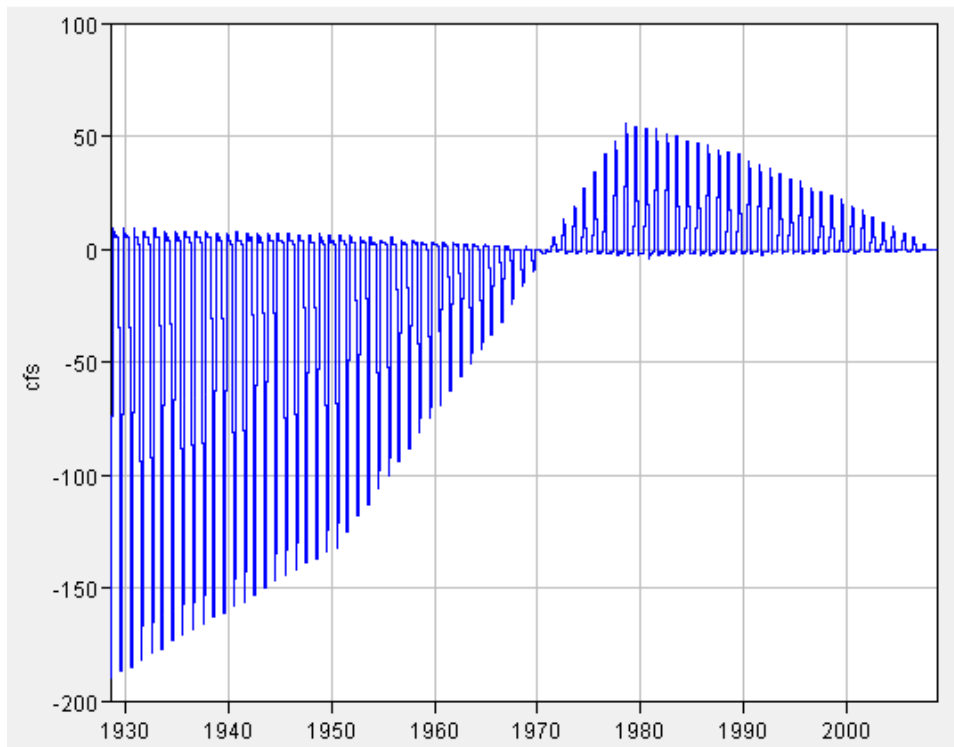

Figure 2-4. Historical Minus 2008 Irrigation Withdrawals and Return Flows between Salem and Albany.

2.4 Methods

The WVS EIS requires a complete hydrologic dataset with homogenous irrigation and evaporation assumptions that extends through water year 2019. The inflow dataset is presented first, followed by the methods used to apply evaporation and irrigation to that basin-wide inflow.

2.4.1 Reservoir Inflows

Reservoir inflows are typically calculated values, not measured values. Only reservoir outflow and elevations are typically measured. The change in storage of the reservoir is calculated by applying the elevation change to the elevation-storage table. Then, inflow is calculated via conservation of mass using known outflow and change in storage. This method is typically used for periods after the reservoir was constructed and is termed the project inflow estimate. For periods before the reservoir was in place, inflow estimates are sourced from statistical relationships with nearby gages. The inflow dataset builds upon work performed in the Willamette Basin Review (USACE 2017a, 2017b).

The 2010 Modified Flows report and the Willamette FIS use different methods to estimate the inflows during the pre-dam period. In general, the Willamette FIS used more rigor and QC when developing these estimates. Even after the reservoirs were constructed, the Willamette FIS and 2010 Modified Flows do not agree. The 2010 Modified Flows used the direct at-site project inflow estimate, which often yields negative inflow values in the summer as evaporation and depletions are embedded in the inflow estimate. The Willamette FIS dataset used two different methods for different seasons of the year (USACE 2011a). In the winter, the at-site project inflow estimate was typically used, with detailed quality control since winter flooding was the primary focus of the study. In the summer, a variety of techniques were taken. In some locations, the at-site project inflow estimates were used directly. Other locations used a smoothing technique to eliminate negative inflows. Other locations used upstream gage records directly rather than using the information at the reservoir site. Table 2-5 shows how the winter and summer flows were derived in the Willamette FIS dataset. The most glaring issue with the Willamette FIS summer inflows is at Fern Ridge Reservoir. The FIS dataset assumes inflows to Fern Ridge Reservoir are solely from the upstream flow gage. While the FIS HEC-ResSim model implementation removes evaporation from these inflows, the significant irrigation depletions taken from Fern Ridge Reservoir are ignored.

The Willamette FIS work was performed in 2011. At that time, the working database for at-site project inflows was Dataquery 1.0 (CDB). The FIS effort performed some QC on these inflow datasets, mostly to remove large spikes in data and fill in any isolated missing estimates. After the working USACE database was transitioned to CWMS in 2012, the inflow calculation methods changed slightly. Therefore, the exact inflow dataset used in the FIS work is no longer available in the CWMS database, and slightly different inflow estimates are used. For instance, at Cottage Grove Reservoir, the FIS efforts used the "QIDPAZZ ZD" dataset from Dataquery 1.0 as a starting point for QC. The daily inflow pathname from the CWMS database is "MIXED-

*Willamette Valley System Operations and Maintenance
Environmental Impact Statement*

COMPUTED-REV,"and the inflow datasets do not match exactly for the period of overlapping data through 2012.

*Willamette Valley System Operations and Maintenance
Environmental Impact Statement*

Table 2-5. Reservoir Inflow Datasets and Calculation Methods in Willamette FIS.

Reservoir	Dataquery 1.0 (CDB) Inflow Code Used in 2011 FIS dataset	Current CWMS (DbQuery or Dataquery 2.0) Inflow Pathname (also shown with an F-part of "BEST" in CWMS)	Dataquery 1.0 data matches Dataquery 2.0 data?	Method for Summer Flows in FIS, 2000–2009 ("Summer" dates are variable by year)
Cottage Grove	QIDPAZZ ZD	COT.Flow-In.Ave.~1Day.1Day.MIXED-COMPUTED-REV	No	Dataquery 1.0 inflows used with negative flows removed or floored.
Dorena	QIDPAZZ ZD	DOR.Flow-In.Ave.~1Day.1Day.MIXED-COMPUTED-REV	No	Taken directly from USGS gage 14154500 (start and end date of "summer" changes by year). No drainage area adjustment applied to the USGS gage flow data.
Fern Ridge	QIDPAZZ ZD	FRN.Flow-In.Ave.~1Day.1Day.MIXED-COMPUTED-REV	No	Taken directly from USGS gage 14166500 (start and end date of "summer" changes by year). No drainage area adjustment applied to the USGS gage flow data.
Blue River	QIDPAZZ ZD	BLU.Flow-In.Ave.~1Day.1Day.MIXED-COMPUTED-REV	No	Before 2003, used USGS gage 14161100 (upstream on Blue River). After gage stopped operating in 2003, Dataquery 1.0 inflows used with negative flows and extreme low flows removed or floored (e.g. September 2009).
Cougar	QIDRXZZAZD	CGR.Flow-In.Ave.~1Day.1Day.CBT-REV	Yes	Dataquery 1.0 inflows used with downward spikes in inflow removed or floored.
Fall Creek	QIDPAZZ ZD	FAL.Flow-In.Ave.~1Day.1Day.MIXED-COMPUTED-REV	No	Dataquery 1.0 inflows used. First, removed negative flow values via QC process. Then, took a 3-day centered moving average of the data.
Hills Creek	QIDRXZZAZD	HCR.Flow-In.Ave.~1Day.1Day.CBT-REV	Yes	Dataquery 1.0 inflows used with QC applied for downward spikes.
Detroit	QIDRXZZAZD	DET.Flow-In.Ave.~1Day.1Day.CBT-REV	Yes	Typically, summer flows used a 7-day average of the Dataquery 1.0 inflows, as evidenced by 2003-2006. 2007 FIS inflows do not match up with the CDB dataset or any known dataset. 2009 summer flows used North Santiam + Breitenbush (not Blowout Creek) USGS gages instead of Dataquery 1.0 inflows.
Green Peter	QIDRXZZAZD	GPR.Flow-In.Ave.~1Day.1Day.CBT-REV	Yes	Dataquery 1.0 inflows used. Negative/zero flows were floored to around 30 cfs.

The definition of what dates comprise the summer season were flexible in the Willamette FIS. Table 2-6 shows the dates when the inflow calculation method switched at Fall Creek Reservoir. It appears that the breakpoints were determined manually to ensure that any large storm events used the at-site project inflow estimates, rather than the more approximate summer techniques. This was appropriate since the study was focused on flood risk management.

Table 2-6. Dates When Inflow Methods Transitioned from Winter to Summer at Fall Creek Reservoir in FIS Dataset.

Calendar Year	Begin Summer	End Summer	Notes
2002	1-May	31-Oct	
2003	1-Apr	31-Oct	
2004	1-Jun	31-Oct	
2005	1-Jun	30-Nov	
2006	1-May	31-Oct	
2007	1-May	30-Sep	Storm in October
2008	1-Mar	31-Oct	
2009	18-May	30-Sep	Minor storm in early May

For the WVS EIS, both the FRM operations in the winter and the conservation season operations in the summer are of interest. To best suit the needs of the study, a composite approach is taken for the inflow dataset. The FIS dataset is used for the period of November–March when high flood flows are most common. The FIS dataset has more detailed QC and gage extension methods for the winter season. The 2010 Modified Flows dataset (data type “A”) is used for the April–October period to ensure the at-site project inflow estimates are used. This dataset is then adjusted to provide consistent levels of irrigation and evaporation, as discussed in the following sections. For the period of 2009–2019, the at-site project inflow estimate from CWMS (Dataquery 2.0) is used for both the summer and winter because evaporation and irrigation are already incorporated into these estimates and are assumed to be similar to 2008 levels of irrigation.

2.4.2 Local Inflows

Local flows are incremental flows that enter the system between upstream inflow points and the next downstream point. These types of flows are needed in the analyses at locations downstream of the dams so that all the water in the system is accounted for. The general process for calculating local flows is to route all known upstream flow hydrographs to the location of interest. These routed flows are then subtracted from the observed flow at this location. The difference is the incremental local flow between upstream inflow points and the location of the local flow. In general, USGS gages are operated just downstream of most WVS dams. In addition, outflow estimates are sometimes available from USACE as calculated values from known gate openings/hydropower generation. Outflows are calculated from rating tables. These calculated outflows are considered less reliable than USGS gages, which are calibrated regularly with measured flow data. Because the USGS gages are slightly downstream of dams, a

*Willamette Valley System Operations and Maintenance
Environmental Impact Statement*

slight drainage area ratio adjustment is often necessary to ensure all contributing drainage area is accounted for.

For the period until 2009, the local flows from the Willamette FIS dataset are used for the WVS EIS. Unlike the reservoir inflows, there was no difference between summer and winter calculation methods for the Willamette FIS local inflows. These records were also used in the USGS regional volume-frequency study because they were calculated based on USGS gage data. The drawback to the Willamette FIS dataset is that it contains no correction to the historical data for changing irrigation through time. The only local inflow points with irrigation depletion estimates from the 2010 Modified Flow report are Salem, Albany, and Oregon City. Therefore, rather than using the Salem, Albany, and Oregon City datasets directly from the existing FIS dataset, the irrigation depletions from the 2010 Modified Flow dataset are added to the FIS dataset at these locations to create a homogenous dataset.

To extend to the period 2009–2019, the same calculation methods from the Willamette FIS records from the USGS gages are used when available. Table 2-7 shows the locations at which observed data is defined for the extension. USGS gages are used for all locations except for Green Peter Dam and Reservoir outflows, Foster Dam and Reservoir inflows, and Lookout Point Dam and Reservoir inflows. In those cases, USGS gages are not available and the flow estimates from Dataquery 2.0 are used.

Local flows between Salem and Oregon City are a special case because inflows were not calculated in the FIS. For the period up to 2008, the 2010 Modified Flow dataset is used. For the period 2009–2019, local flows are calculated using the methods outlined by WEST, which are very similar to the 2010 Modified flow report (USACE 2018a).

*Willamette Valley System Operations and Maintenance
Environmental Impact Statement*

Table 2-7. Observed Flow Locations with HEC-DSS Pathnames to Calculate Local Flows.

Location	A-Part	B-Part	C-Part	F-Part
Willamette_at Salem	WILLAMETTE RIVER	WILLAMETTE RIVER AT SALEM, OR (14191000)	FLOW	USGS
Willamette_at Harrisburg	WILLAMETTE RIVER	WILLAMETTE RIVER AT HARRISBURG, OR (14166000)	FLOW	USGS
Willamette_at Albany	WILLAMETTE RIVER	WILLAMETTE RIVER AT ALBANY, OR (14174000)	FLOW	USGS
So Santiam_nr Foster	SOUTH SANTIAM NR FOSTER	14187200	FLOW	USGS
So Santiam_at Waterloo	SOUTH SANTIAM AT WATERLOO	14187500	FLOW	USGS
Santiam_at Jefferson	SANTIAM RIVER	SANTIAM RIVER AT JEFFERSON, OR (14189000)	FLOW	USGS
Row_nr Cottage Grove	DOR	14155500	FLOW	USGS
No Santiam_at Niagara	DET	14181500	FLOW	USGS
No Santiam_at Mehama	NORTH SANTIAM AT MEHAMA	14183000	FLOW	USGS
Mckenzie_at Vida	MCKENZIE RIVER NEAR VIDA	14162500	FLOW	USGS
McKenzie+SF McKenzie	CGR	14159500	FLOW	USGS
MF Willamette_nr Dexter	MF WILLAMETTE RIVER NR DEXTER	14150000	FLOW	USGS
MF Willamette_at Jasper	MIDDLE FORK WILLAMETTE AT JASPER	14152000	FLOW	USGS
MF Willamette_abv Salt Crk	HCR	14145500	FLOW	USGS
Long Tom_nr Alvadore	FRN	14169000	FLOW	USGS
Long Tom_at Monroe	LONG TOM RIVER	LONG TOM RIVER AT MONROE, OR (14170000)	FLOW	USGS
Green Peter_OUT		GPR	FLOW-OUT	BEST
Fall_btw Winberry Cr nr Fall Creek	FAL	14151000	FLOW	USGS
CF Willamette_nr Goshen	COAST FORK WILLAMETTE NEAR GOSHEN	14157500	FLOW	USGS
CF Willamette_blw Cottage Grove Dam	COT	14153500	FLOW	USGS
Blue_at Blue River	BLU	14162200	FLOW	USGS
Foster_IN		FOSTER	FLOW-IN	DATAQUERY-EDITED
Lookout Point_IN		LOOKOUT POINT	FLOW-IN	DATAQUERY-EDITED

2.4.2.1 Streamflow Routing

The Willamette FIS effort began from a District HEC-ResSim model from 2010. This model used SSARR (Streamflow Synthesis and Reservoir Routing) routing parameters, which had been in use historically. The Willamette FIS was more focused on short-duration flood routings and therefore revisited the channel routing methods and parameters. WEST consultants completed a report providing new routing methods and parameters focused on an hourly timestep (USACE 2011b). Some reaches were converted from SSARR routing to Muskingum-Cunge 8-point routing. These routing parameters were used when calculating the FIS local flows (USACE 2013). While these routings were applied in the HEC-ResSim model used for the FIS, the daily HEC-ResSim models used for other projects (e.g., Willamette River Basin Review, COP, BiOp implementation) continued to use the original SSARR routing parameters. The AFDR HEC-ResSim model also uses the SSARR routing parameters. In 2018, WEST revisited the routing parameters between Salem and Willamette Falls to be used on an hourly timestep (USACE 2018a). The proposed revision to routing still uses the SSARR method with adjusted parameters to better match observed data on an hourly timestep.

The original SSARR parameters are used for the WVS EIS local flows and HEC-ResSim model. Because a general-purpose HEC-ResSim model is desired at a daily timestep, the finer level of detail afforded by the FIS routing methods or the new 2018 routing methods from Salem to Willamette Falls is not necessary. There are slight discrepancies on a daily timestep when calculating locals with the different routings. Therefore, the original SSARR parameters are used for the WVS EIS local flows and HEC-ResSim model.

2.4.2.2 Computation Mechanics

To calculate local inflows for 2009–2019, there are a series of computational steps required. The District’s Annual Flood Damage Reduction (AFDR) HEC-ResSim model is used to automate this calculation procedure (USACE 2015a).

Local flows for 2009–2019 are calculated using observed gage data with built-in AFDR model functionality. The observed flow datasets used to calculate local flows are summarized in Table 2-7. After the AFDR model is used to calculate local flows, three sites need additional modifications to ensure they are aligned with the FIS processes. Jasper, Waterloo, and Mehama require manual post-processing. For more details, see Section 2.6, Local Flow Calculation Methods.

Local flows at Oregon City are a special case because there has never been a gage in operation that estimates streamflow. Stage estimates are available at Willamette Falls but not streamflow. The methods applied at Oregon City are also detailed in Section 2.6, Local Flow Calculation Methods. In brief, the local flow is a sum of gaged flows on tributaries between Salem and Oregon City.

2.4.3 Evaporation

Reservoir inflows are calculated as a function of reservoir outflow and change in elevation over time periods when project data exists. Evaporation is inherent to this calculation because evaporation slightly lowers reservoir elevations. The effects of annual variation in reservoir elevations and climate are also embedded in these inflows. Insufficient data exists to reliably estimate evaporation as a function of annual climate variation. The remaining independent variables to model evaporation are average monthly surface evaporation rates and elevation, leaving the following two options for incorporating evaporation into the inflow dataset:

1. **Directly model evaporation in HEC-ResSim.** The volume of water lost to evaporation is a function of the surface area of the reservoir. Because the surface area of the reservoir depends on the pool elevation, evaporation losses could vary if reservoir operations were modified. For instance, if the pool is held at lower levels, the evaporative losses would be less. If the evaporative loss volumes are an important factor to capture for different alternatives, this approach should be taken.
2. **Embed evaporation into the inflow dataset.** This approach assumes the same volume of evaporative losses for each individual year irrespective of changes in reservoir surface area resulting from changes in reservoir operations.

The WVS reservoirs generally have low evaporative losses during the summer compared to their conservation storage volumes, as shown in Table 2-4. The exception is Fern Ridge Reservoir, which has a large surface area relative to the volume of the reservoir. Evaporation was modeled directly in HEC-ResSim at Fern Ridge Reservoir (Option 1) because it is relatively significant at that location and alternatives may significantly change Fern Ridge pool elevations in the summer. This was done by calculating the evaporative losses at Fern Ridge Reservoir as a function of average monthly evaporation as reported in Table 2-2 and observed reservoir elevations. This estimated evaporation was added back into the inflow data set. Finally, HEC-ResSim was programmed to calculate evaporative losses as a function of evaporation rates and modeled elevation. At all other locations, evaporative losses inherent to the inflow dataset will remain (Option 2), and no evaporative losses are modeled in the HEC-ResSim model. Evaporation is considered negligible in the free-flowing river that existed pre-reservoir and so no correction is made to the inflow hydrology for the years prior to the construction of Fern Ridge Dam.

2.4.4 Withdrawals

The withdrawals are used to adjust each year of record to provide a homogenous hydrologic dataset set to a consistent irrigation level. Ideally, irrigation depletions from the 2020 Modified Flow report would be applied to bring the dataset to 2018 levels. However, the 2020 report was not yet available, so the 2010 level depletions (water year 2008) were used as a starting point. The new data from 2009–2019 is assumed to have irrigation levels consistent with water year 2008. These depletions were directly incorporated into the inflow dataset. The 2020 Modified Flows study was released during development of the EIS inflow dataset. The increase in

cumulative withdrawals at Willamette Falls between 2008–2018 is estimated to be at most 165 cfs, functionally all of which is to be withdrawn below Salem (Figure 2-5).

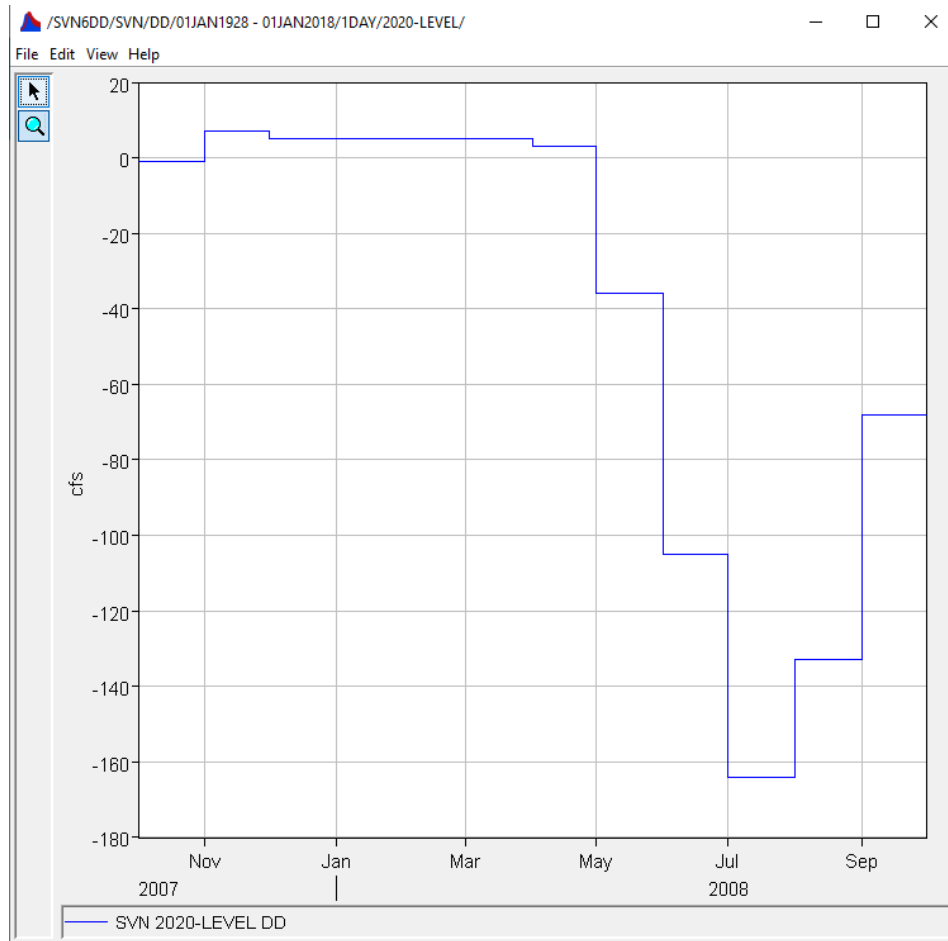

Figure 2-5. Increase in Irrigation Withdrawals between 2008–2018 at Oregon City Falls.

2.5 Results

This section provides validation results for the dataset extension from 2009–2019. Water year 2009 is an overlap year where both new flow extension results are available as well as existing Willamette FIS dataset. Section 2.7, Water Year 2009 Validation Results, includes plots for each flow location comparing the existing datasets and the flow extension performance for water year 2009. A brief discussion of the performance is provided in the following sections.

2.5.1 Reservoir Inflows

Reservoir inflows generally show fairly close agreement between the Willamette FIS dataset and the dataset extension. Differences are due to the change from Dataquery 1.0 (CDB) to Dataquery 2.0 (CWMS) in the winter. In the summer, differences at Dorena and Fern Ridge Reservoirs are notable because the FIS used upstream USGS gage records while the extended dataset uses the at-site project inflow estimate from Dataquery 2.0. The at-site project inflow

record includes the effect of evaporation and depletions, leading to very low and sometimes negative net inflows.

2.5.2 Reservoir Inflows

The local flows calculated from the dataset extension match the FIS dataset well at all locations except Salem. There are slight differences at other locations, stemming from different routing parameters. The differences at Salem are more exaggerated. It appears they are largely due to channel routing differences. While the local flows at Salem stand out as having the largest deviation, this is unlikely to affect reservoir operations substantially because Salem local flows are a very small portion of total inflows to the Willamette River Basin.

The local flows at Oregon City from the dataset extension match the 2010 Modified Flows well for the comparison year of water year 2008. There are slight differences in volume, but they are relatively minor.

2.5.3 Evaporation

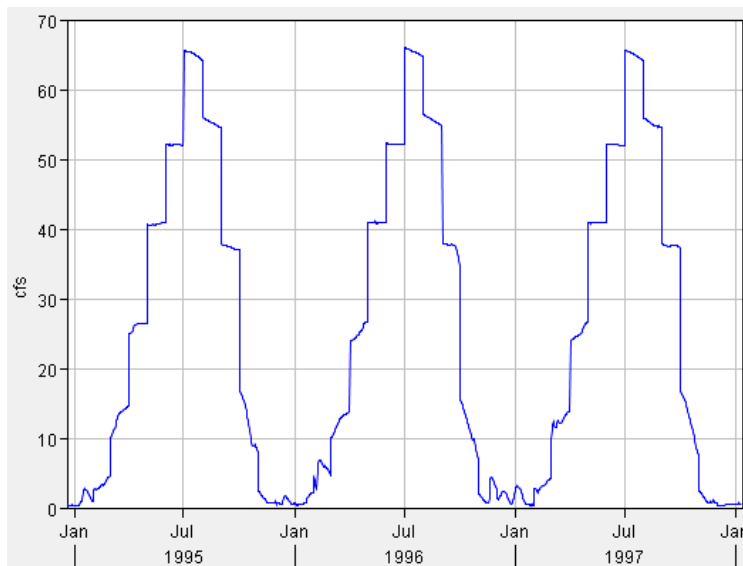

Figure 2-6. Three Example Years (1995–1997) of Calculated Evaporation from Fern Ridge Reservoir.

Figure 2-6 shows 3 years of estimated daily evaporation from Fern Ridge Reservoir, calculated using monthly evaporation rates as reported in Table 2-2 and observed reservoir elevations. Calculated evaporation volumes are added to the Fern Ridge Reservoir inflow for the POR to reflect a pre-reservoir condition. Evaporative losses were then calculated in HEC-ResSim as a function of monthly average evaporation rates and modeled reservoir surface area. This approach shows different evaporative effects for different operational alternatives.

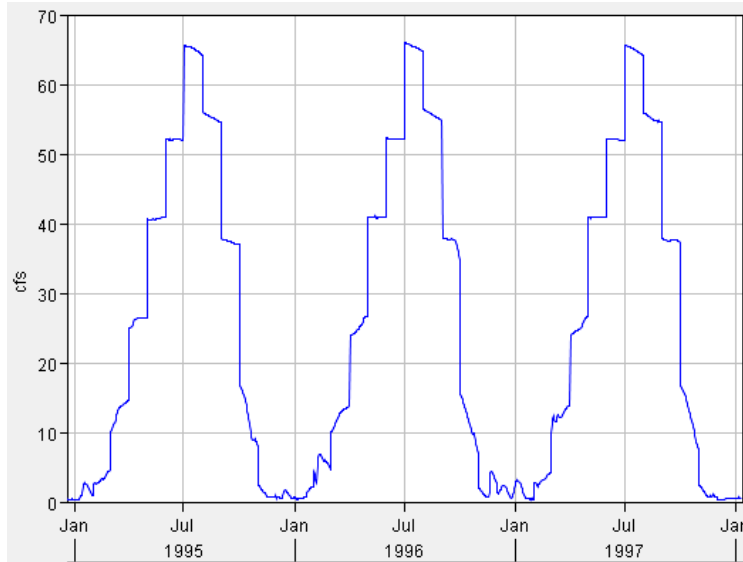

Figure 2-7. Fern Ridge Reservoir Daily Evaporation in CFS.

2.6 Local Flow Calculation Methods

This section provides the routing methods that are used to calculate local flows for the dataset extension from 2009–2019. These routing diagrams were sourced from the Willamette FIS report. The same methods for calculating local flows applied in the Willamette FIS (see also USACE 2015b) are applied here for the extension. The routing parameters used in the flow extension for the EIS are the SSARR routing parameters, while the FIS used a mix of SSARR routings and 8-point Muskingum-Cunge routings.

2.6.1 Mehama

Observed flow of USGS 14183000 minus routed flow of USGS 14181500 (Niagra) adjusted by DAR (1.091). The inflows between Detroit Dam and Big Cliff Dam are included in the Mehama local rather than in the Detroit Dam and Reservoir inflow—that is the purpose of the drainage area ratio.

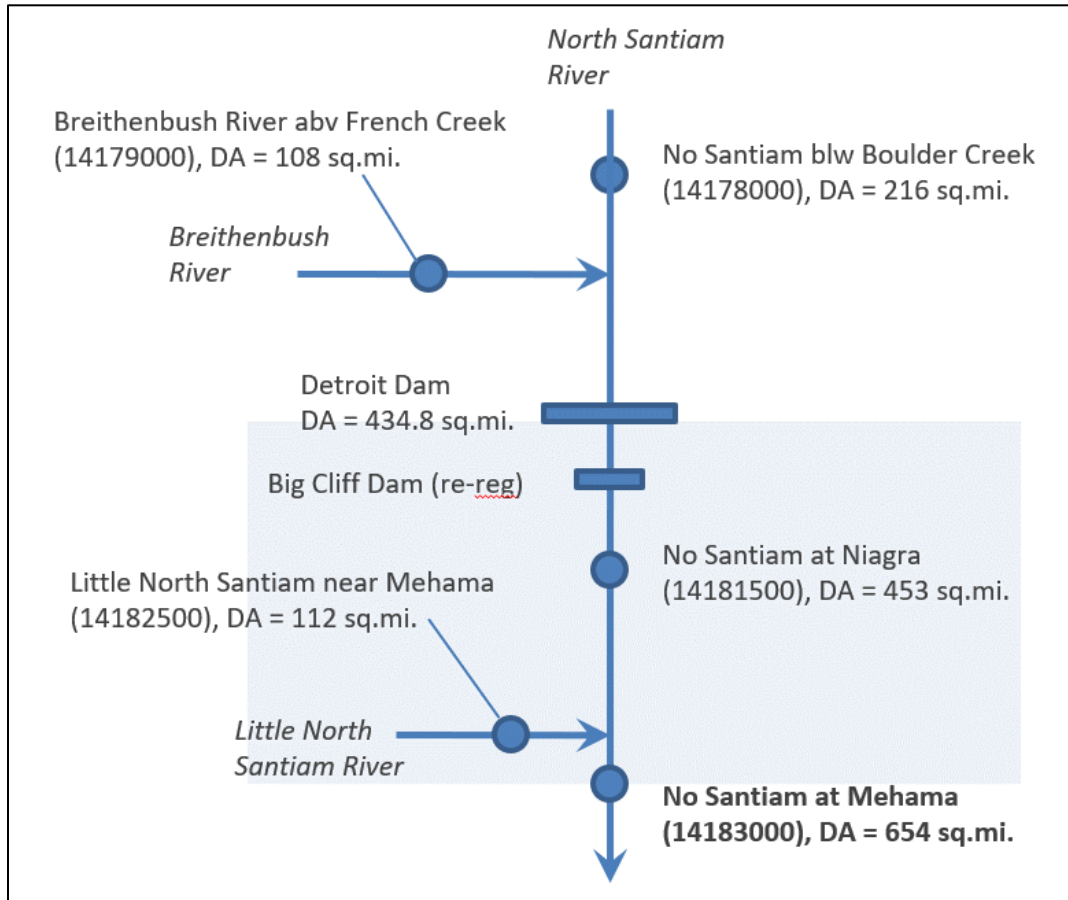

Figure 2-8. Mehama Routing Diagram.

2.6.2 Foster Dam and Reservoir

Observed Inflow at Foster Dam from Dataquery minus routed releases of Green Peter Dam from Dataquery.

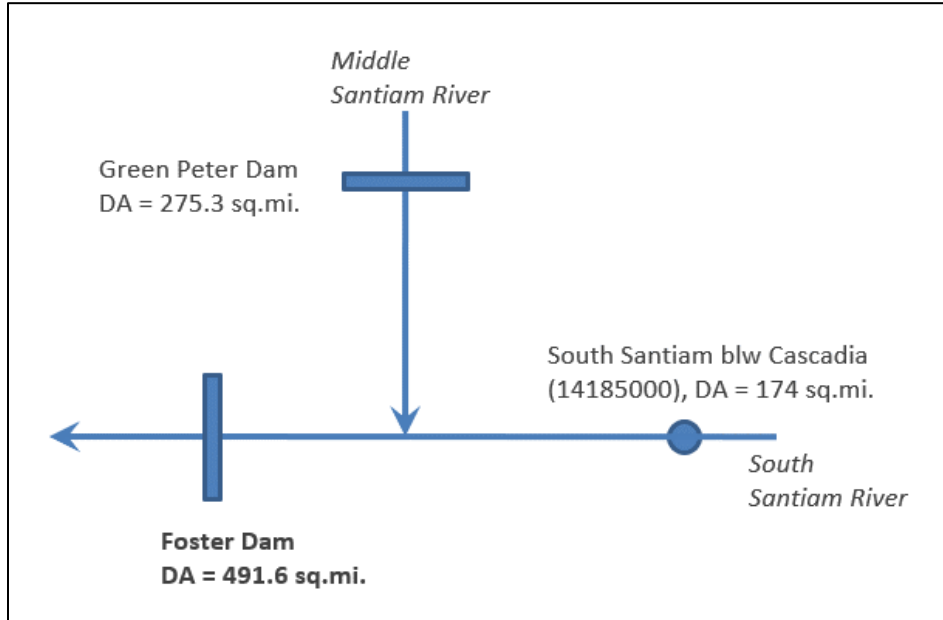

Figure 2-9. Foster Dam and Reservoir Routing Diagram.

Willamette Valley System Operations and Maintenance
Environmental Impact Statement

2.6.3 Waterloo

Observed flow of USGS 14187500 (Waterloo) minus routed flow of USGS 14187200 (So Santiam nr Foster). Adjust flow by Drainage Area of 1.164, which accounts for the total area downstream of Foster Dam and USGS 14187000 (Wiley Cr nr Foster) and upstream of USGS 14187200 (So Santiam nr Foster). Then, add USGS 14187000 (Wiley Cr nr Foster) observed flow.

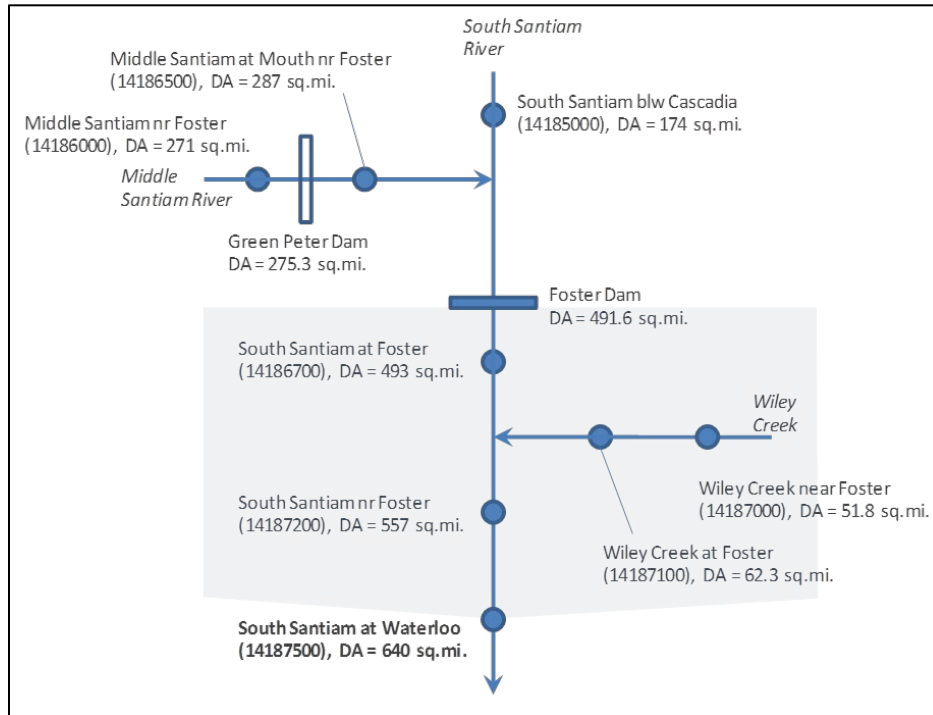

Figure 2-10. Waterloo Routing Diagram.

2.6.4 Jefferson

Observed flow of USGS 14189000 (Jefferson) minus combined routed flows of USGS 14187500 (Waterloo) and 14183000 (Mehama).

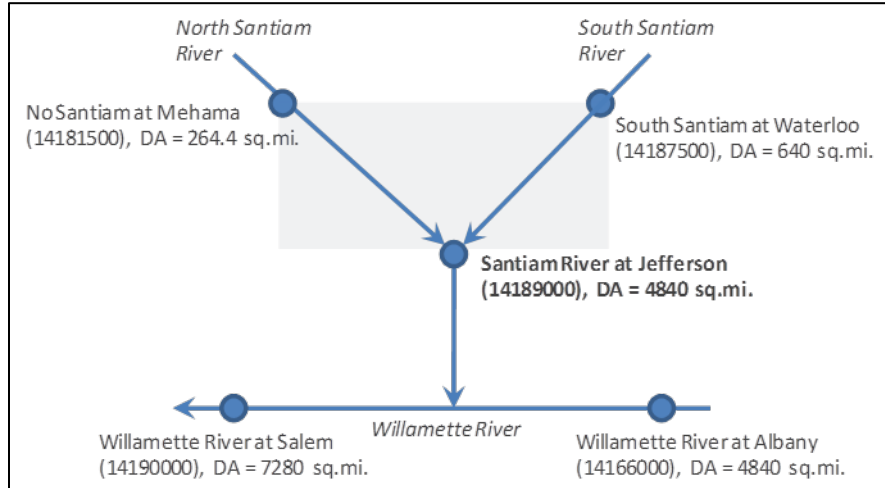

Figure 2-11. Jefferson Routing Diagram.

2.6.5 Monroe

Observed flow of USGS 14170000 (Monroe) minus routed flows of USGS 14169000 (Alvadore).

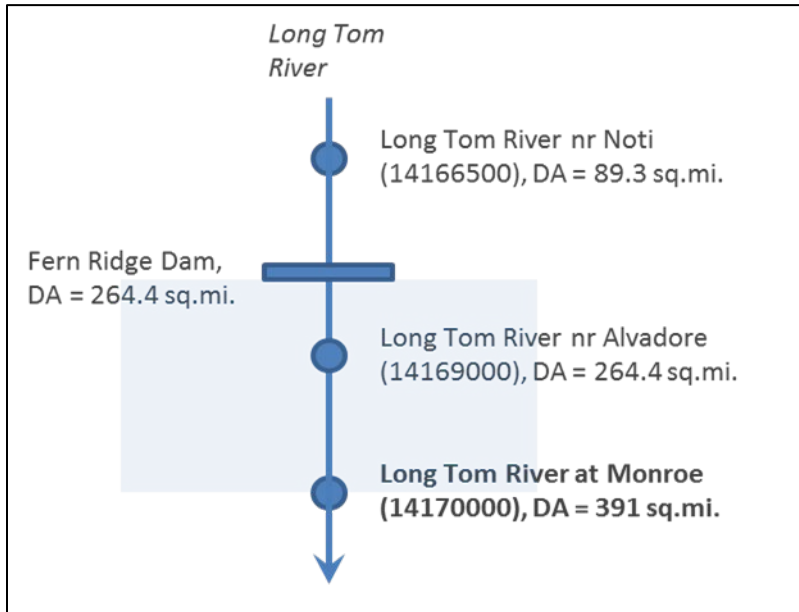

Figure 2-12. Monroe Routing Diagram.

Willamette Valley System Operations and Maintenance
Environmental Impact Statement

2.6.6 Vida

Observed flow of USGS 14162500 (Vida) minus combined routed flow of USGS 14162200 (Blue River at Blue River) and 14159500 (SF McKenzie).

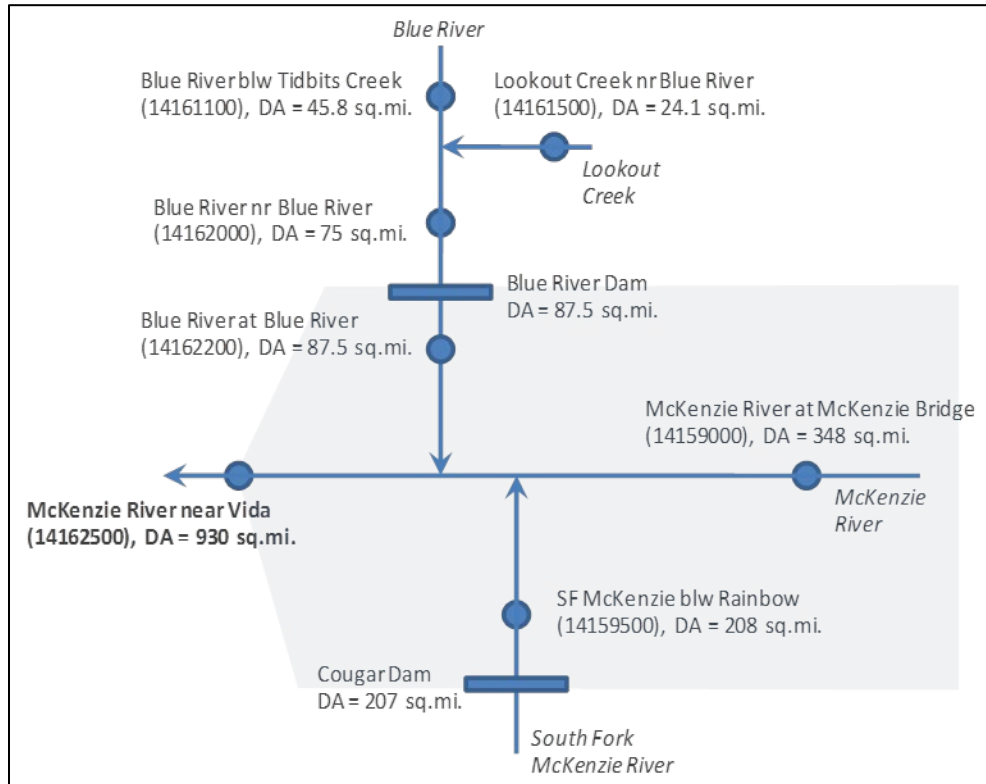

Figure 2-13. Vida Routing Diagram.

Willamette Valley System Operations and Maintenance
Environmental Impact Statement

2.6.7 Lookout Point

Observed inflow at Lookout Point Reservoir from Dataquery minus routed flows of USGS 14145500 (MF Willamette River above Salt Creek Near Oakridge).

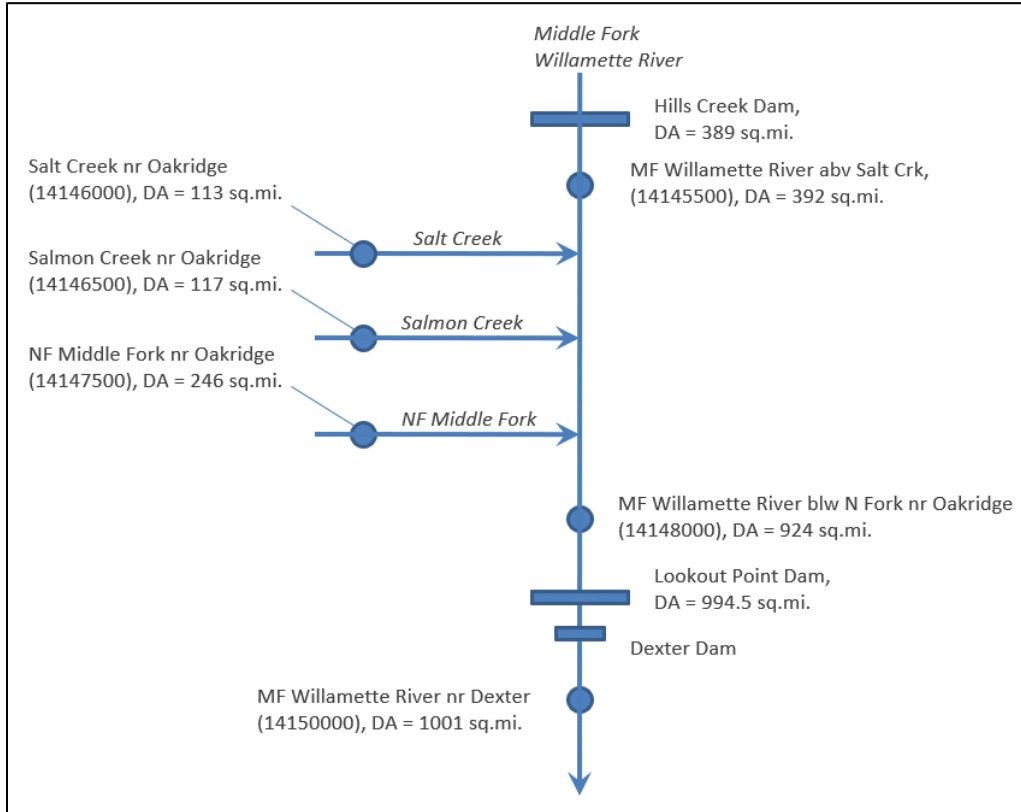

Figure 2-14. Lookout Point Dam and Reservoir Routing Diagram.

Willamette Valley System Operations and Maintenance
Environmental Impact Statement

2.6.8 Jasper

Observed flow of USGS 14152000 (Jasper) minus combined routed flows of USGS 14150000 (Dexter) and 14151000 (Fall Creek). Then, multiply by the drainage area ratio (1.056) to capture area between the dam and the gage.

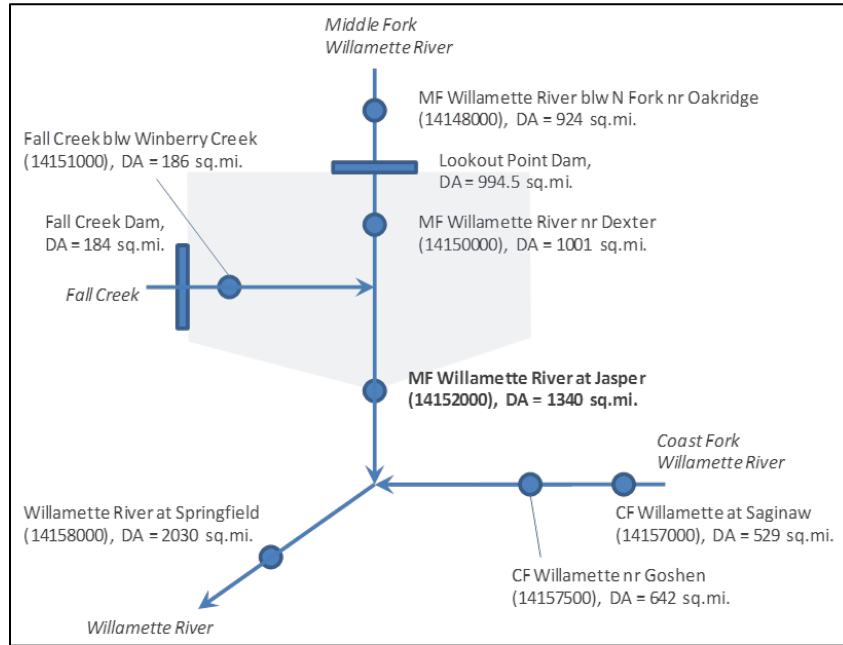

Figure 2-15. Jasper Routing Diagram.

*Willamette Valley System Operations and Maintenance
Environmental Impact Statement*

2.6.9 Goshen

Observed flow of USGS 14157500 (Goshen) minus combined routed flows of USGS 14153500 (CF Willamette below Cottage Grove) and 14155500 (Row River near Cottage Grove).

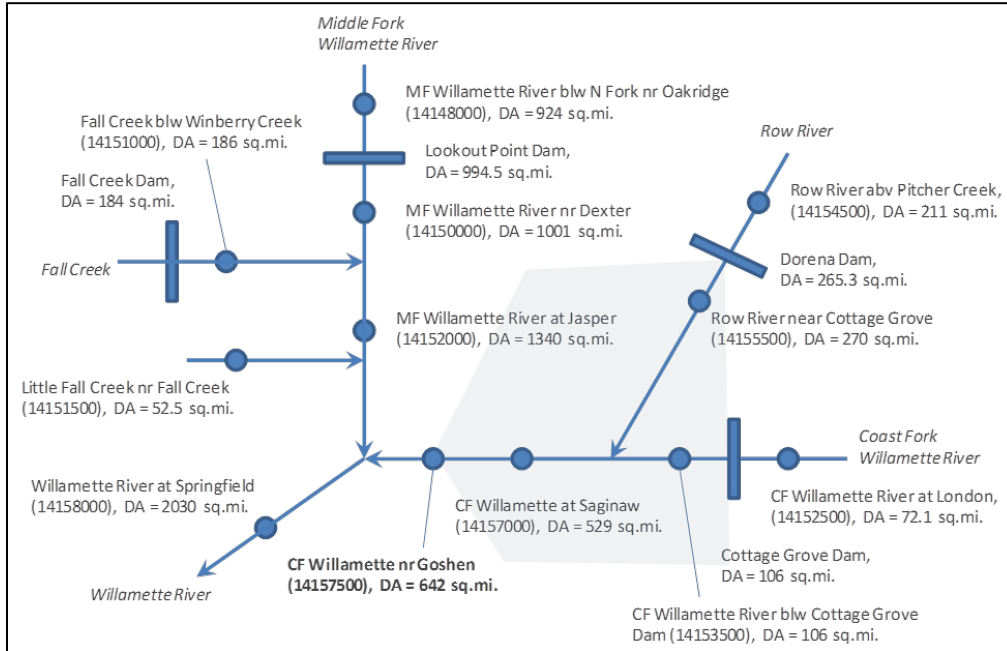

Figure 2-16. Goshen Routing Diagram.

*Willamette Valley System Operations and Maintenance
Environmental Impact Statement*

2.6.10 Harrisburg

Observed flow of USGS 14166000 (Harrisburg) minus combined routed flows of USGS 14157500 (Goshen), 14152000 (Jasper), and 14162500 (Vida).

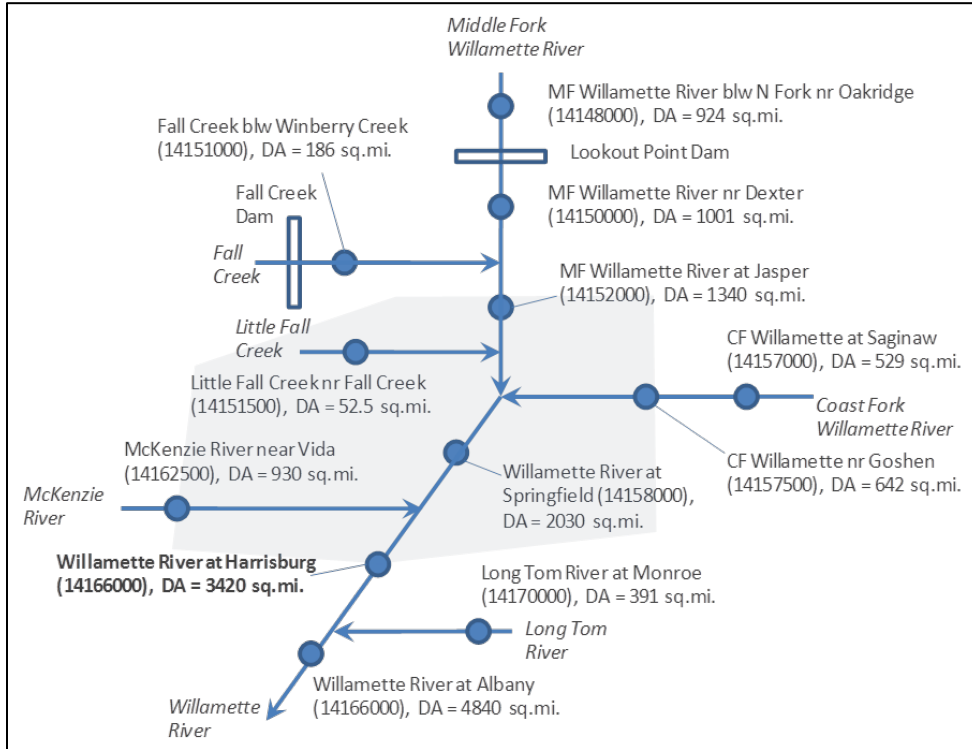

Figure 2-17. Harrisburg Routing Diagram.

2.6.11 Albany

Observed flow of USGS 14174000 (Albany) minus combined routed flows of Monroe on the Long Tom (14170000) and Harrisburg on the main stem Willamette River (14166000).

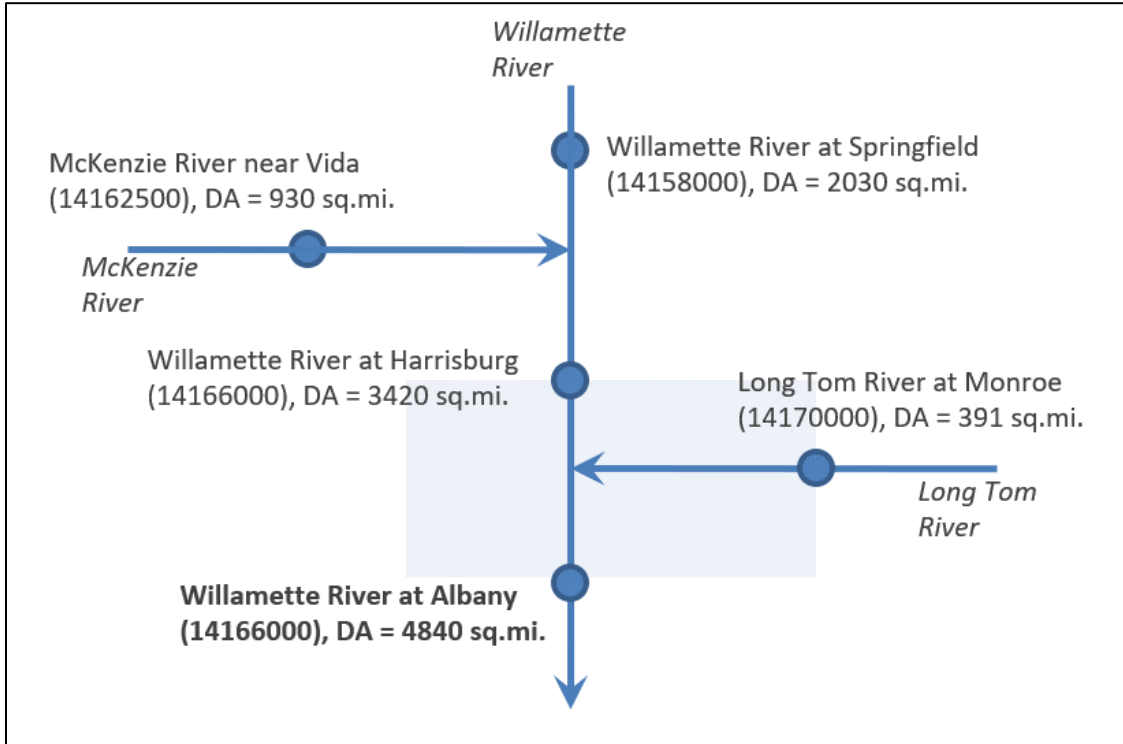

Figure 2-18. Albany Routing Diagram.

2.6.12 Salem

Observed Flow at Salem (14191000) minus combined routed flows of Albany (14174000) and Jefferson (14189000).

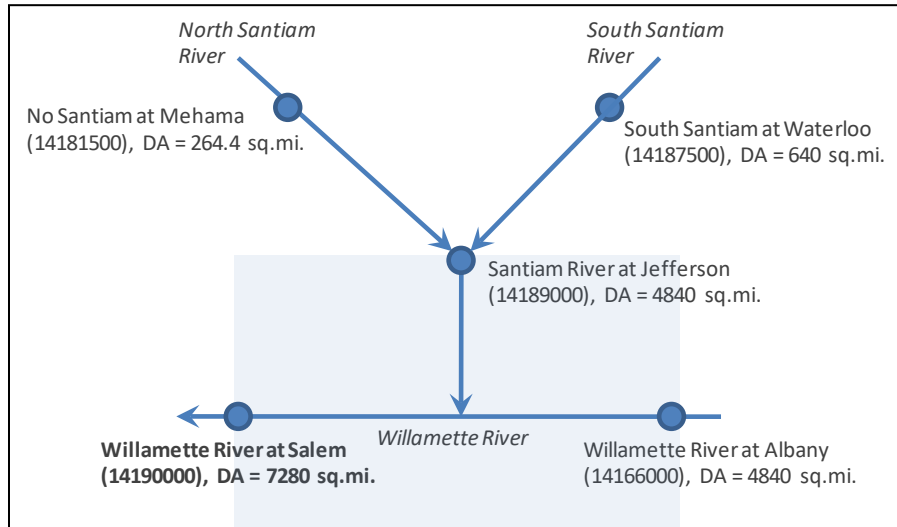

Figure 2-19. Salem Routing Diagram.

2.6.13 Oregon City

Local flows at Oregon City help provide a complete dataset for the Willamette River Basin, but they do not have the same level of confidence as other local flows. There is no reliable rating curve at Oregon City, so gaged streamflow estimates are not available at this location. The 2010 Modified Flow Report calculates local flows at Oregon City by estimating total flows at Oregon City, then subtracting the routed observed flows from Salem. The estimated total flows at Oregon City are a simple sum of seven components:

1. Observed flows at Salem
2. South Yamhill River (14194150)
3. North Yamhill River (14194300, not presently operated)
4. Molalla River (14200000)
5. Pudding River (14202000)
6. Tualatin River (14207500)
7. Ungaged Streamflow allowance

The 2010 Modified flow method uses the observed flows at Salem twice—once when estimating the total flows at Salem and once when routing the observed flows from Salem to

Willamette Falls using SSARR methods. For the 2009–2019 period, the method proposed by WEST (USACE 2018a) is used. This method is very similar in concept to the 2010 Modified Flow method, but it is slightly simpler and easier to apply. The only major difference between the methods is the accounting of the North Yamhill River. The 2010 Modified Flow method estimates the North Yamhill flows using a correlation to a gage on the Siletz River, while the WEST method simply applies a ratio to the South Yamhill River gage. The 2010 Modified Flow report uses a factor of 1.5 applied to the Pudding River to estimate ungaged flows while the WEST method uses 1.59, which is a fairly minimal difference.

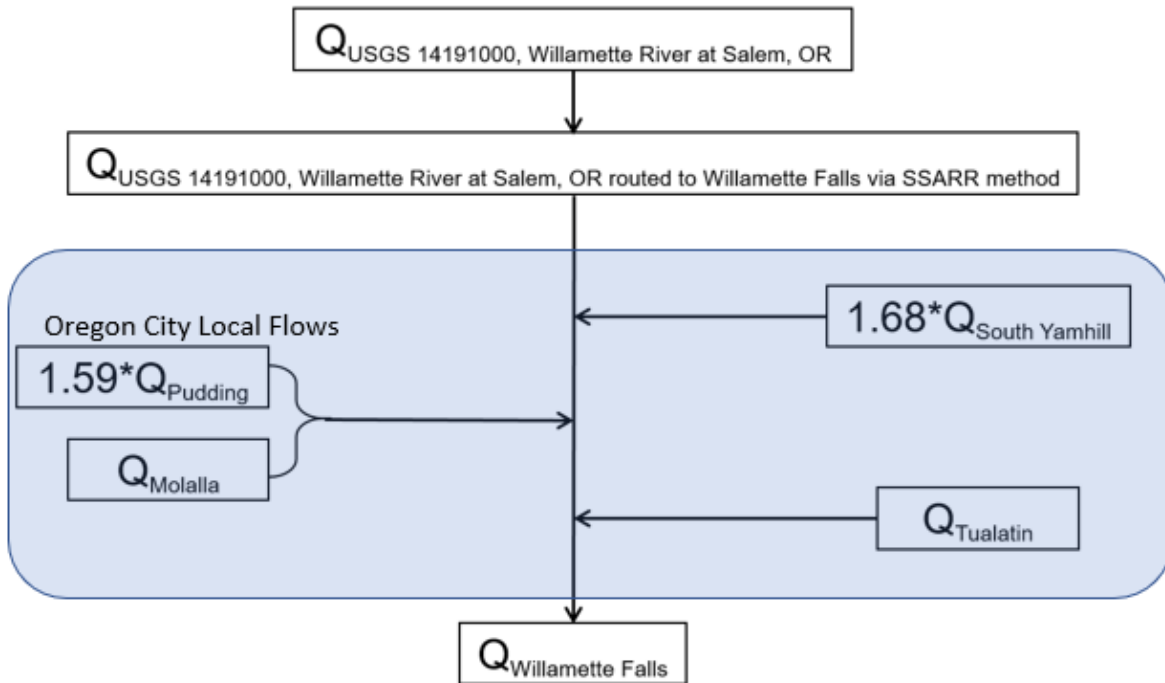

Figure 2-20. Oregon City Routing Diagram.

2.7 Water Year 2009 Validation Results

The dataset extension was performed for water years 2009–2019. Water year 2009 has data overlap with the Willamette FIS dataset. The results of the dataset extension were validated to the Willamette FIS existing data to ensure that the new methods were performing adequately.

2.7.1 Reservoir Inflows

The data from Dataquery 2.0 (CWMS) is used in the WVS EIS for inflow estimates at reservoirs. The following plots compare this data source to the inflows used in the Willamette FIS study, which were Dataquery 1.0 (CDB) data for the winter. For the summer, different locations used different methods in the FIS, as previously discussed. The FIS dataset is shown in blue, and the extended dataset used for the EIS is shown in red.

Willamette Valley System Operations and Maintenance
Environmental Impact Statement

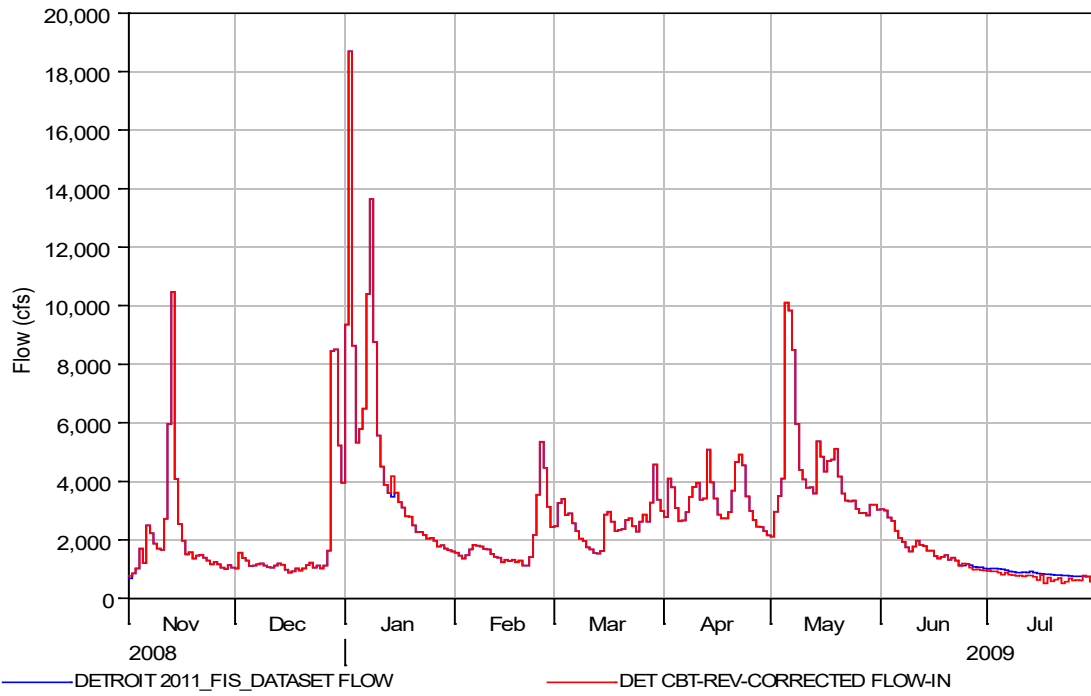

Figure 2-21. Water Year 2009 Comparison at Detroit Reservoir.

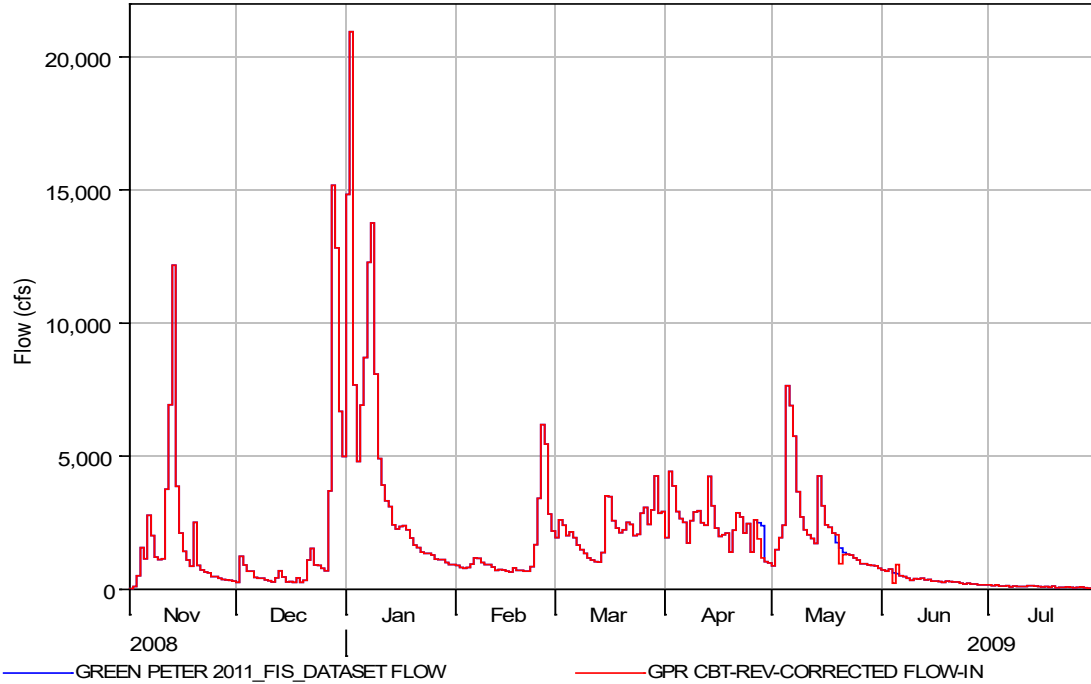

Figure 2-22. Water Year 2009 Comparison at Green Peter Reservoir.

*Willamette Valley System Operations and Maintenance
Environmental Impact Statement*

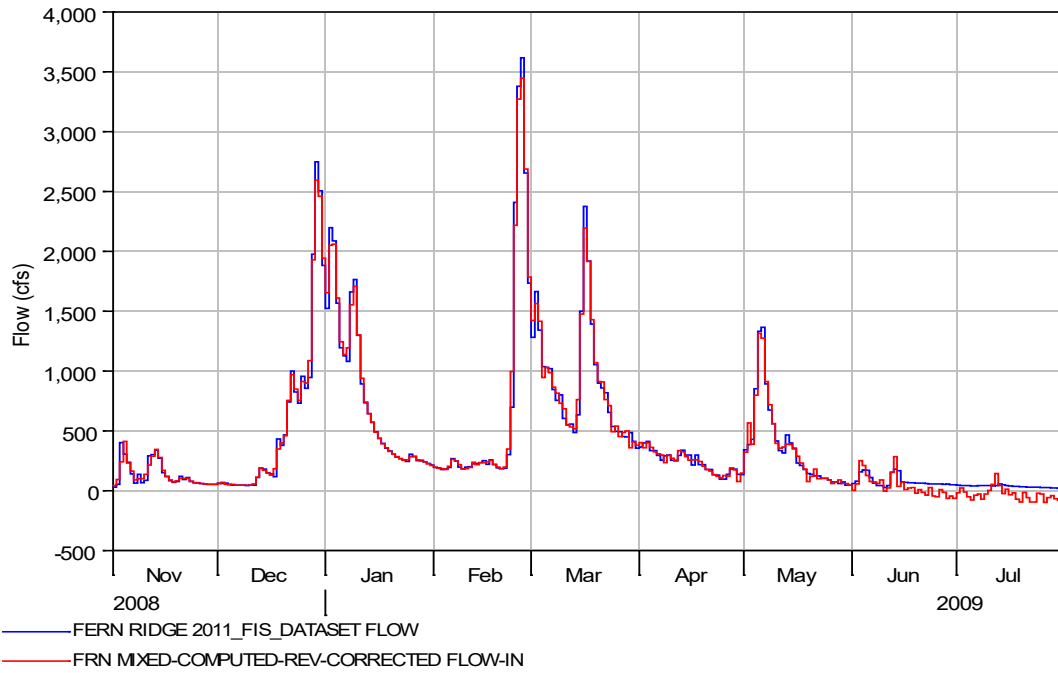

Figure 2-23. Water Year 2009 Comparison at Fern Ridge Reservoir.

As previously noted, the FIS uses the upstream flow gage while the dataset extension approach uses the at-site project inflow estimate.

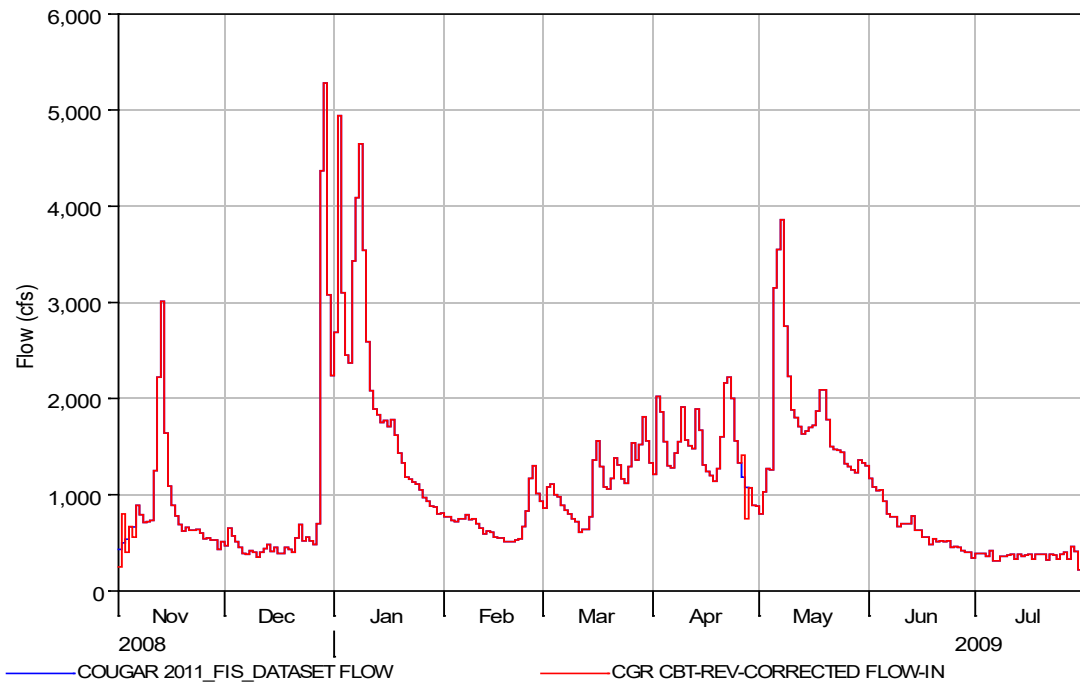

Figure 2-24. Water Year 2009 Comparison at Cougar Reservoir.

Willamette Valley System Operations and Maintenance
Environmental Impact Statement

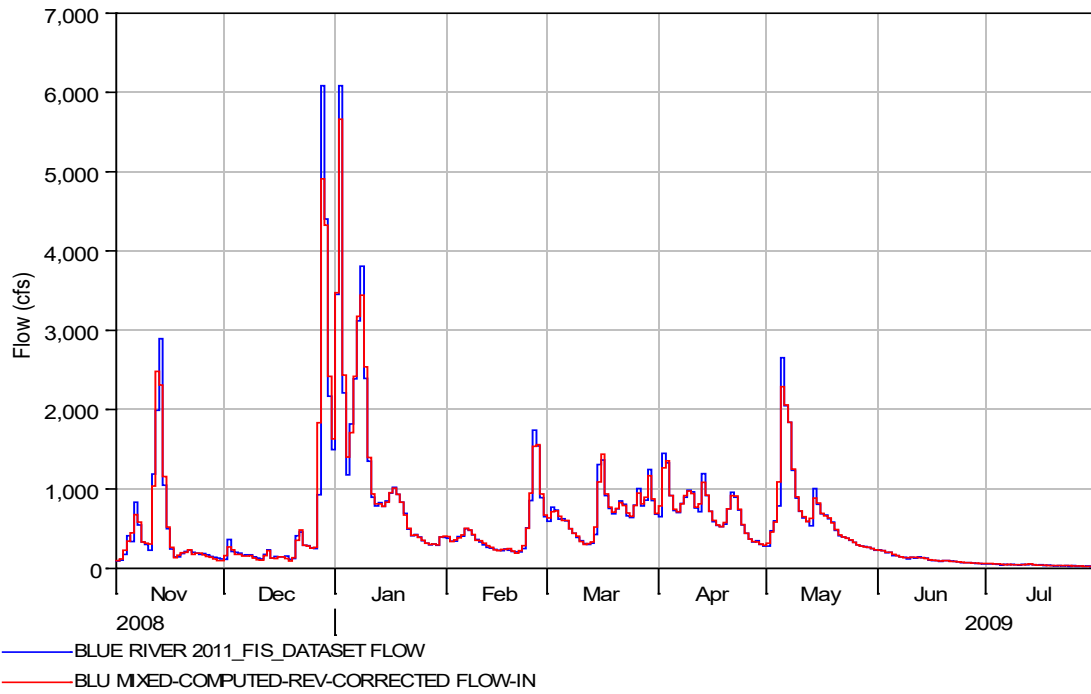

Figure 2-25. Water Year 2009 Comparison at Blue River Reservoir.

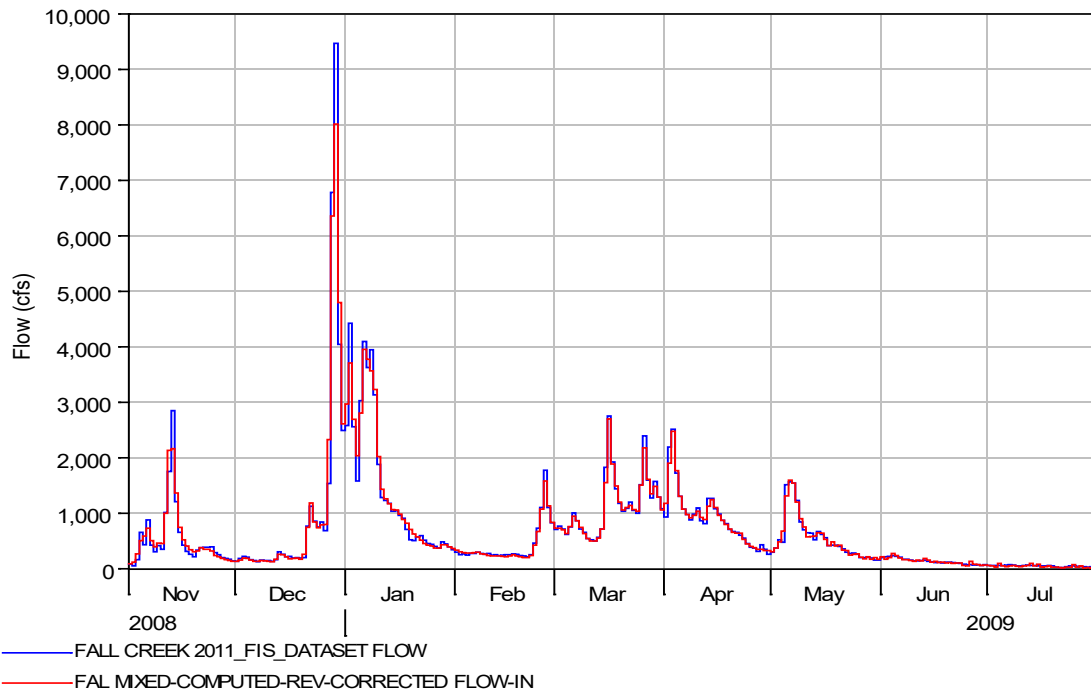

Figure 2-26. Water Year 2009 Comparison at Fall Creek Reservoir.

Willamette Valley System Operations and Maintenance
Environmental Impact Statement

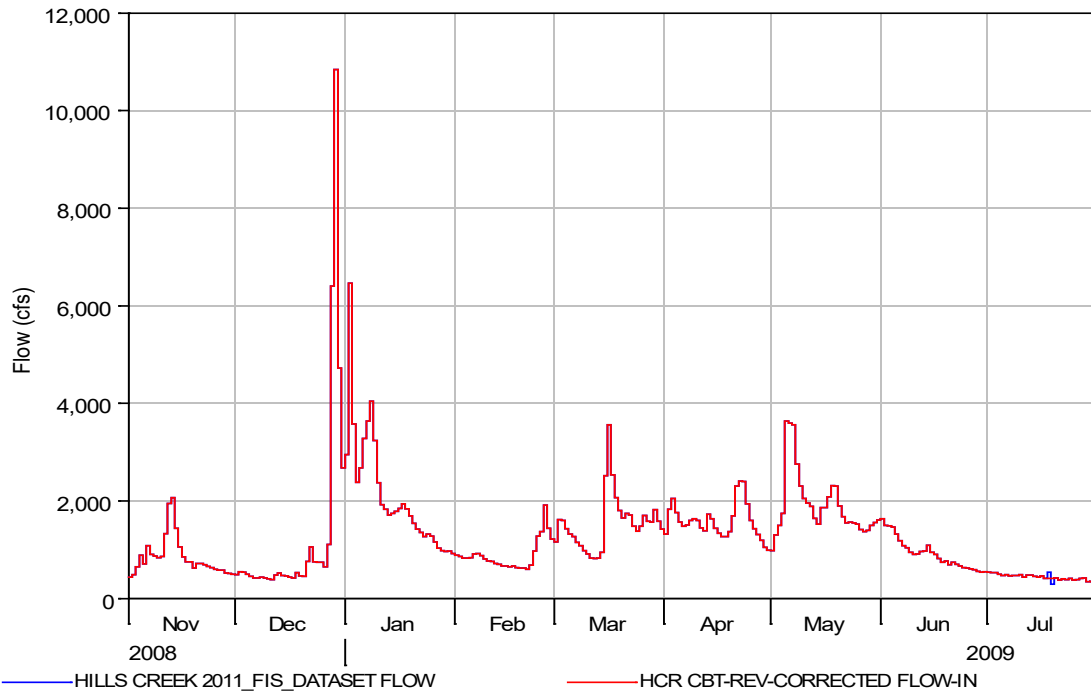

Figure 2-27. Water Year 2009 Comparison at Hills Creek Reservoir.

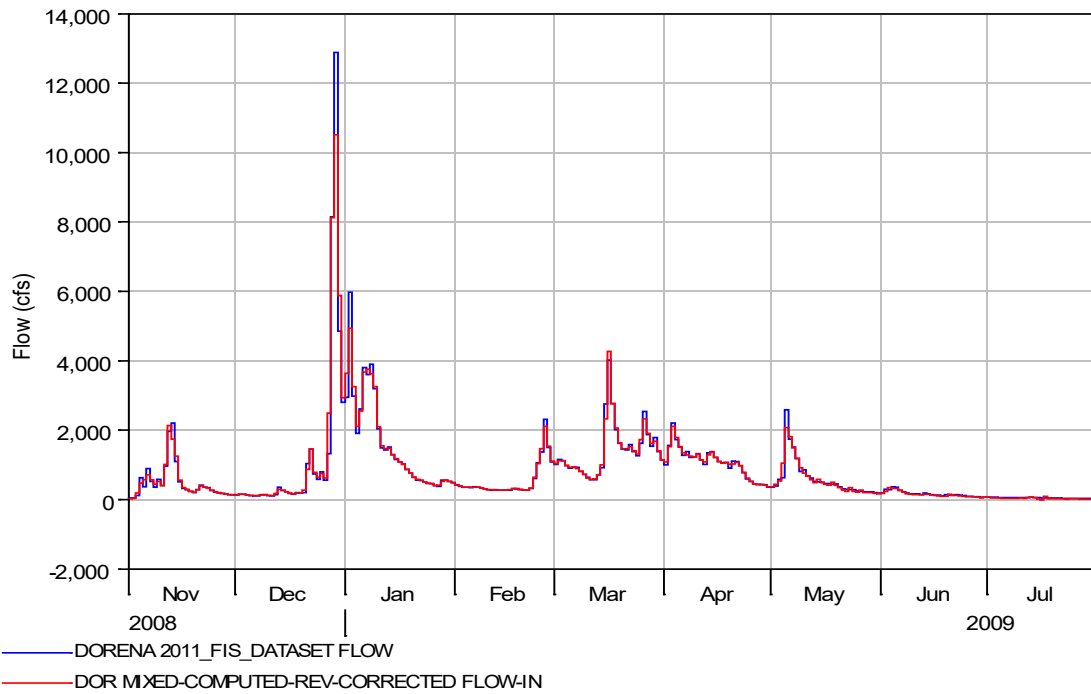

Figure 2-28. Water Year 2009 Comparison at Dorena Reservoir.

Willamette Valley System Operations and Maintenance
Environmental Impact Statement

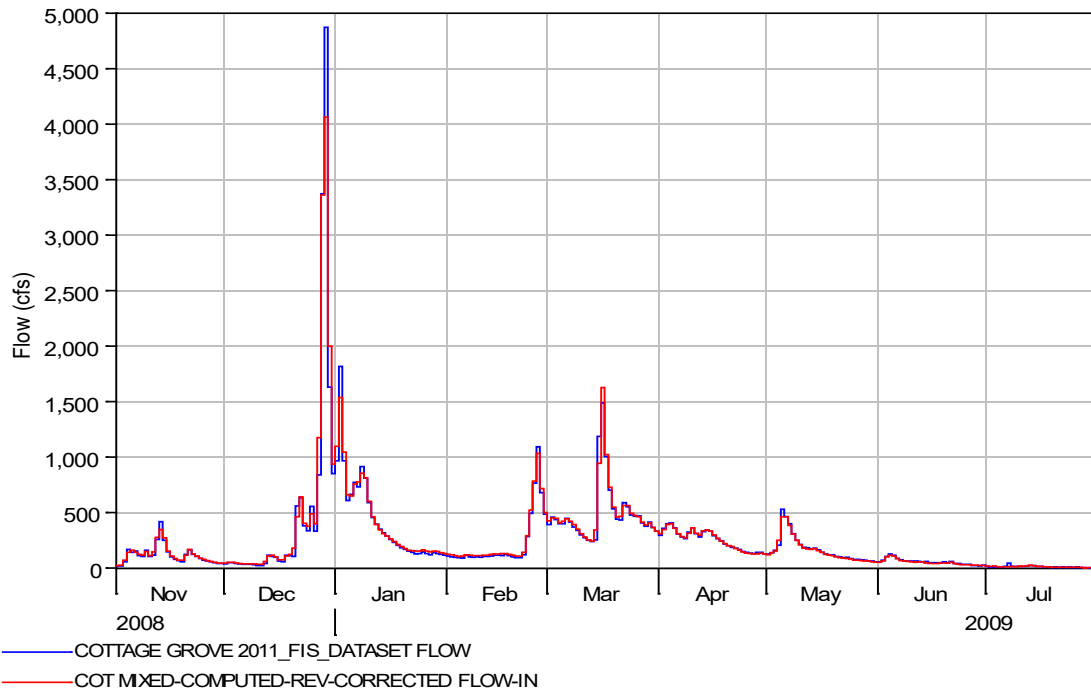

Figure 2-29. Water Year 2009 Comparison at Cottage Grove Reservoir.

2.7.2 Local Inflows

The local flows from the Willamette FIS dataset are compared to the results from the flow extension in the following plots. The blue lines are the FIS data and the green dashed lines are the new computed values.

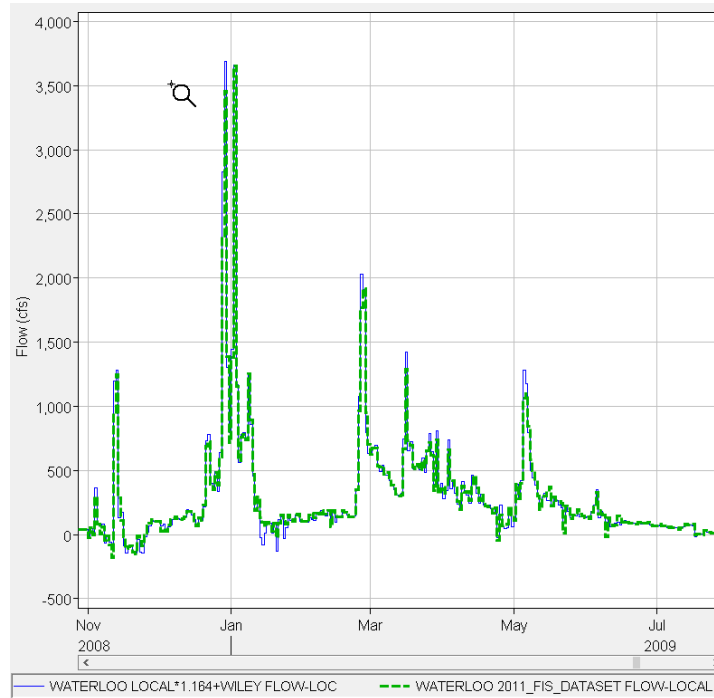

Figure 2-30. Water Year 2009 Comparison at Mehama, OR.

Willamette Valley System Operations and Maintenance
Environmental Impact Statement

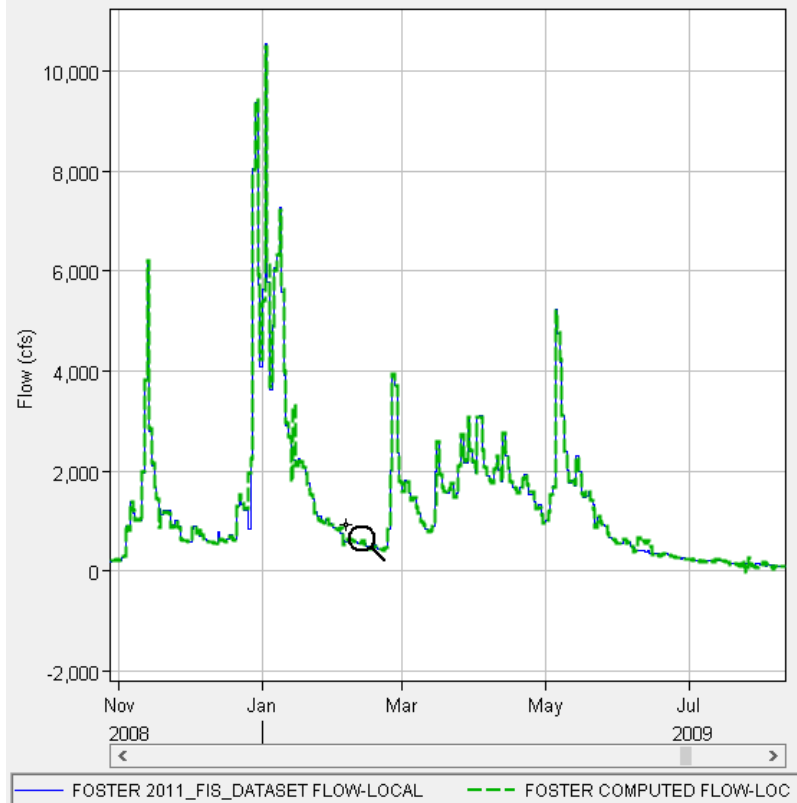

Figure 2-31. Water Year 2009 Comparison at Local Inflow at Foster Dam and Reservoir.

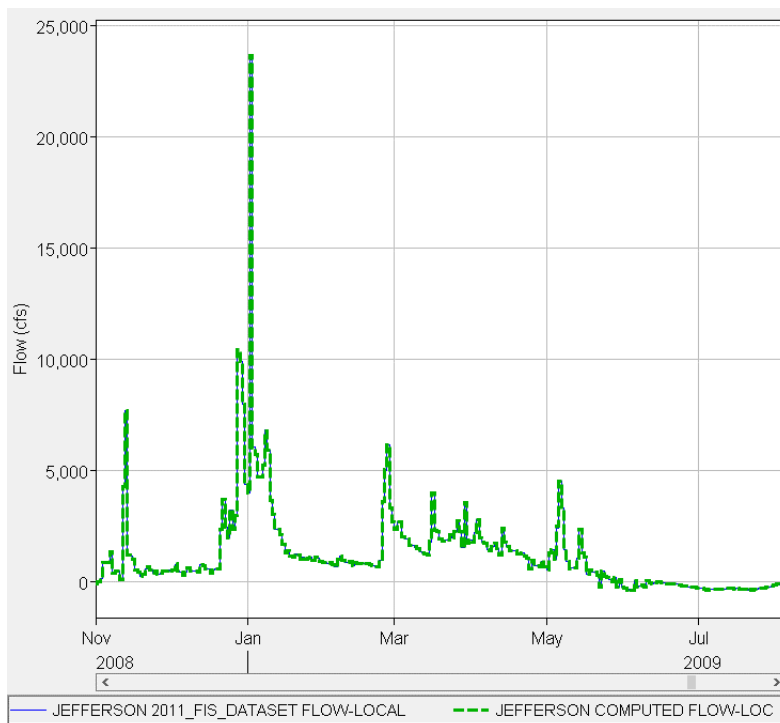

Figure 2-32. Water Year 2009 Comparison at Jefferson, OR.

Willamette Valley System Operations and Maintenance
Environmental Impact Statement

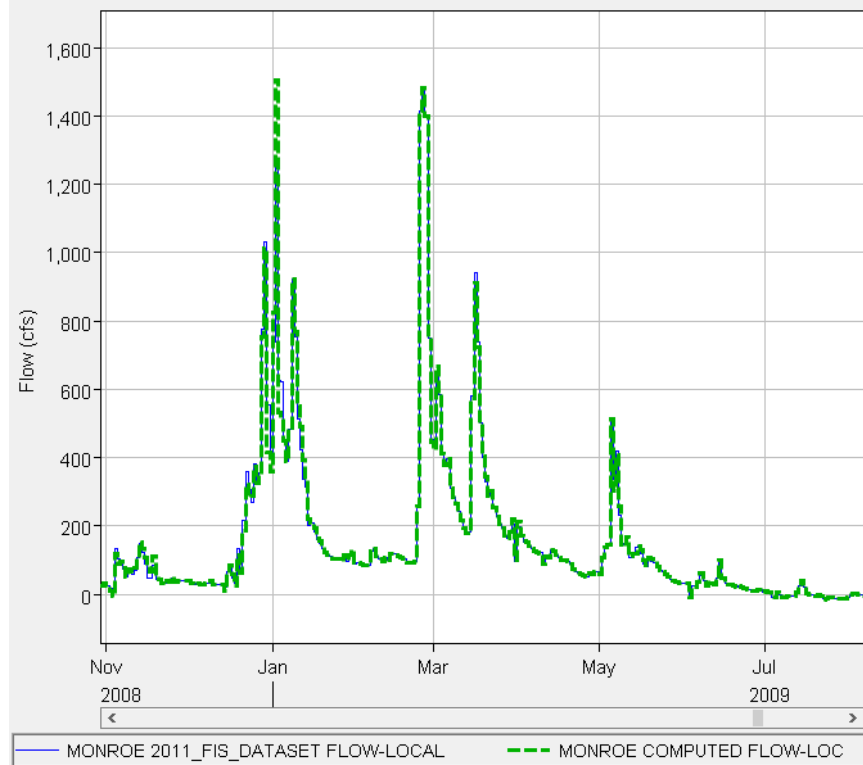

Figure 2-33. Water Year 2009 Comparison at Monroe, OR.

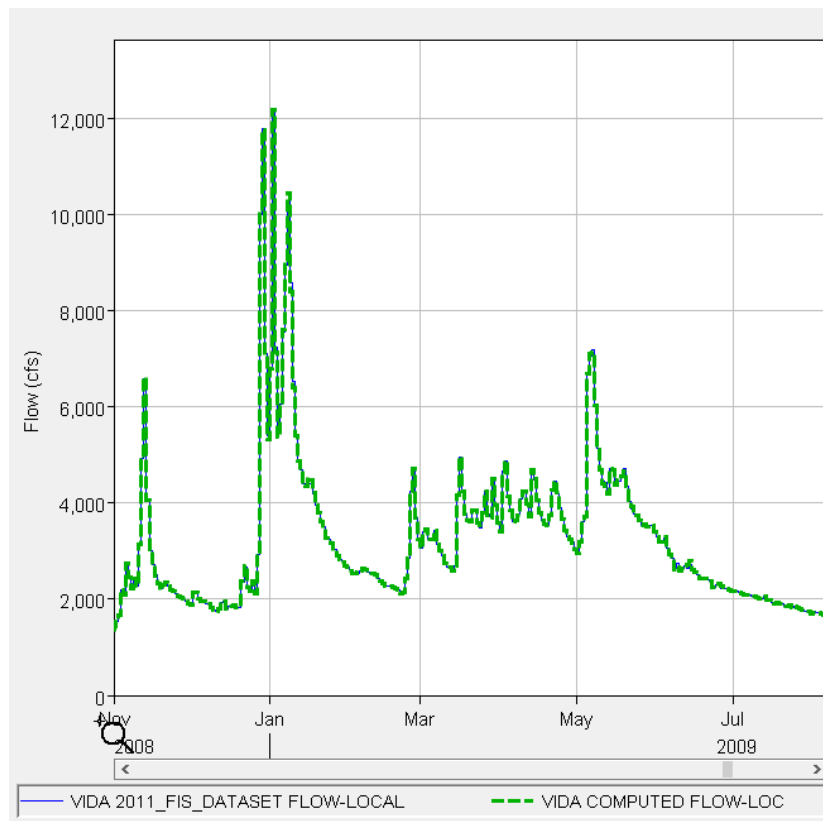

Figure 2-34. Water Year 2009 Comparison at Vida, OR.

*Willamette Valley System Operations and Maintenance
Environmental Impact Statement*

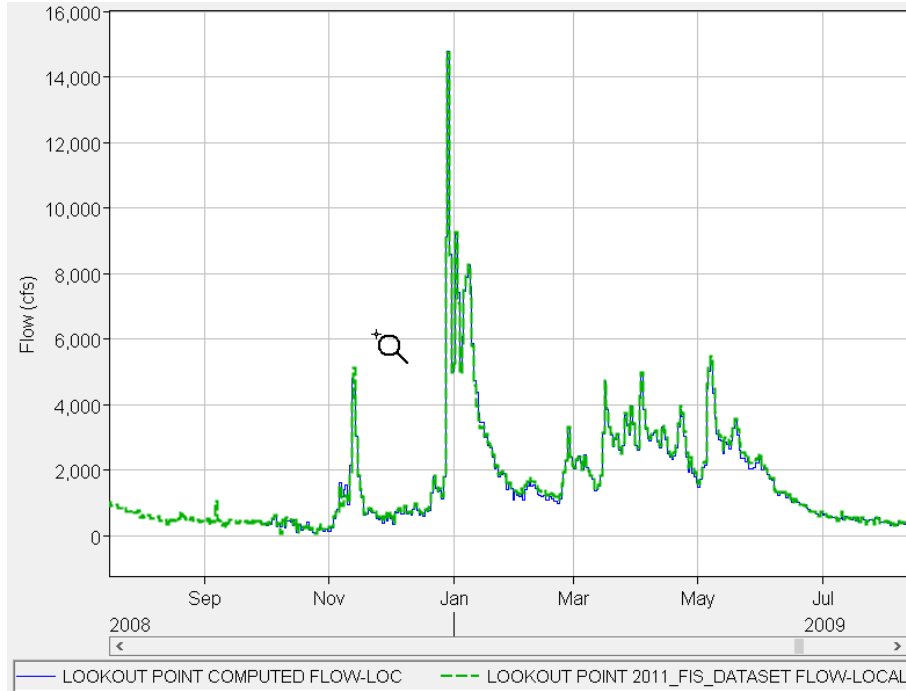

Figure 2-35. Water Year 2009 Comparison at Local Inflow at Lookout Point Dam and Reservoir.

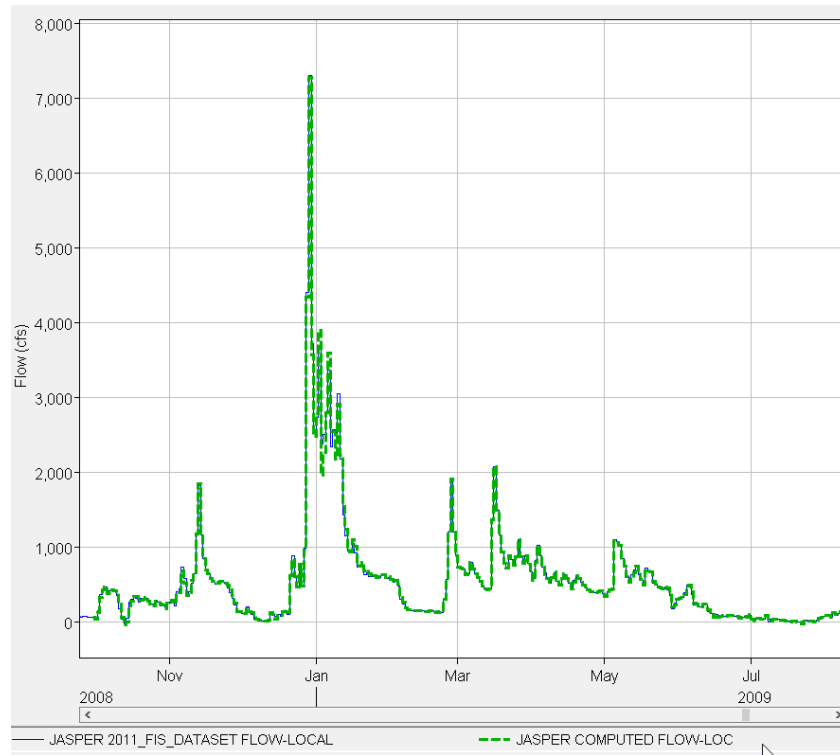

Figure 2-36. Water Year 2009 Comparison at Jasper, OR.

*Willamette Valley System Operations and Maintenance
Environmental Impact Statement*

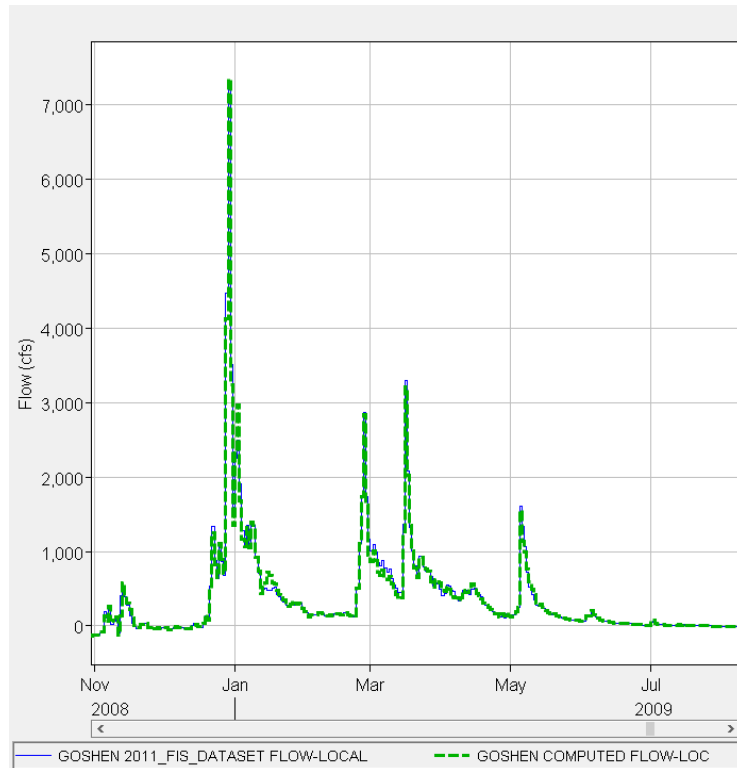

Figure 2-37. Water Year 2009 Comparison at Goshen, OR.

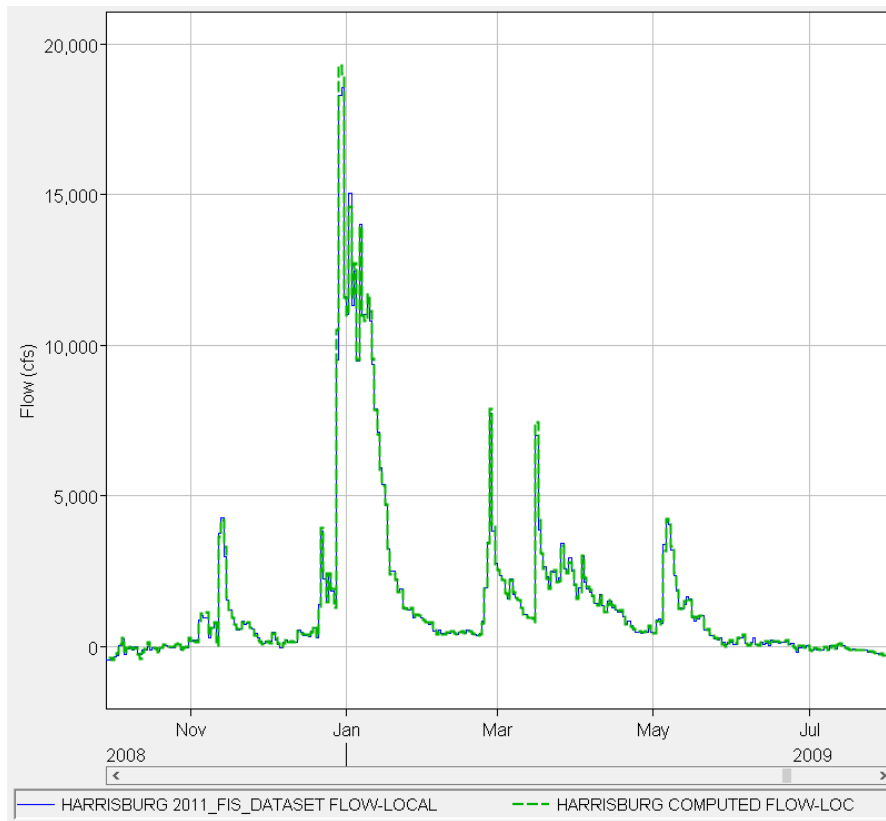

Figure 2-38. Water Year 2009 Comparison at Harrisburg, OR.

*Willamette Valley System Operations and Maintenance
Environmental Impact Statement*

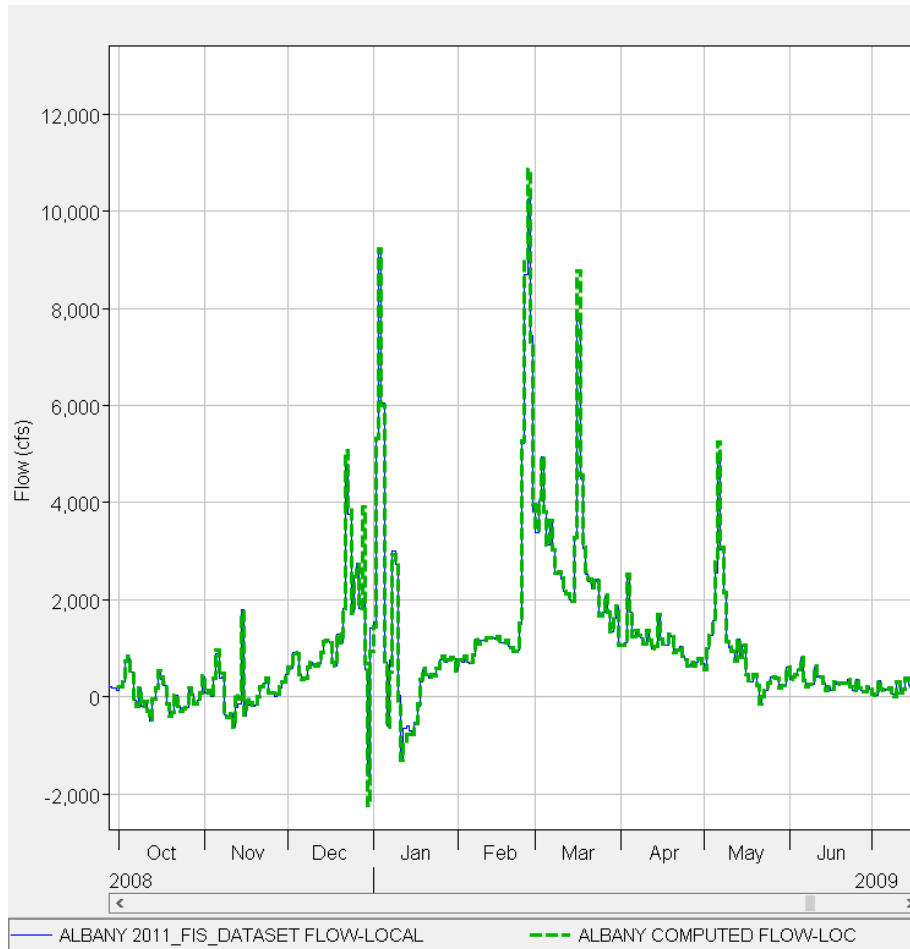

Figure 2-39. Water Year 2009 Comparison at Albany, OR.

The Salem location shows significant differences between the Willamette FIS and the computed flow extension. It is a bit unclear exactly how the FIS performed the calculation. From the FIS documentation: “Flow at Salem (14191000) and the upstream gages at Albany (14174000) and Jefferson (14189000). Direct locals are available with the gage on the Luckiamute River near Suver (14190500).” It is not clear exactly how the Luckiamute was treated specially in the Willamette FIS. The treatment of the Luckiamute may be one reason for the discrepancy, but another likely reason is the difference in routing parameters. Routing used in FIS dataset is 8-point Muskingum-Cunge. In the EIS HEC-ResSim model, SSARR routing is used from Jefferson and from Albany. In the EIS HEC-ResSim model, there is no routing from the confluence of the Santiam and Willamette Rivers to Salem.

Willamette Valley System Operations and Maintenance
Environmental Impact Statement

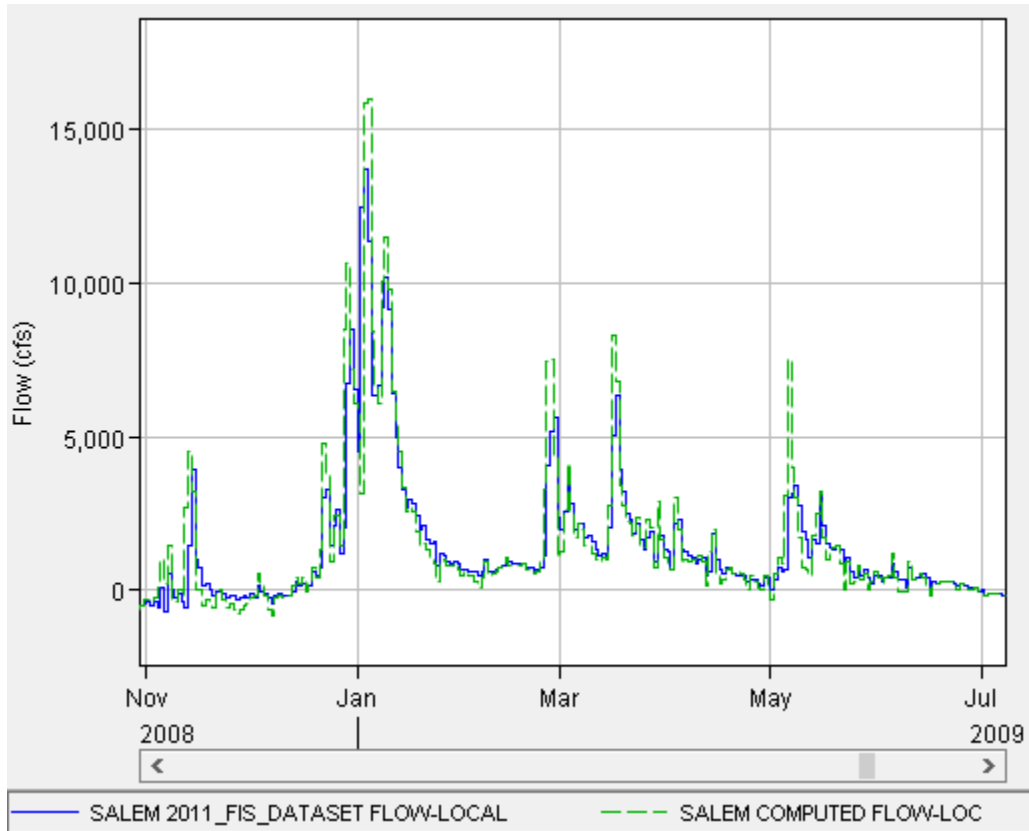

Figure 2-40. Water Year 2009 Comparison at Salem, OR.

At Oregon City, the comparison is between the 2010 Modified Flow dataset and the 2018 WEST method (USACE 2018a). The overlap year is 2008, since the 2010 Modified Flow dataset only extends through Water Year 2008. The two methods are similar with the WEST method providing a slightly higher peak for the winter flood, but slightly lower volumes in the spring.

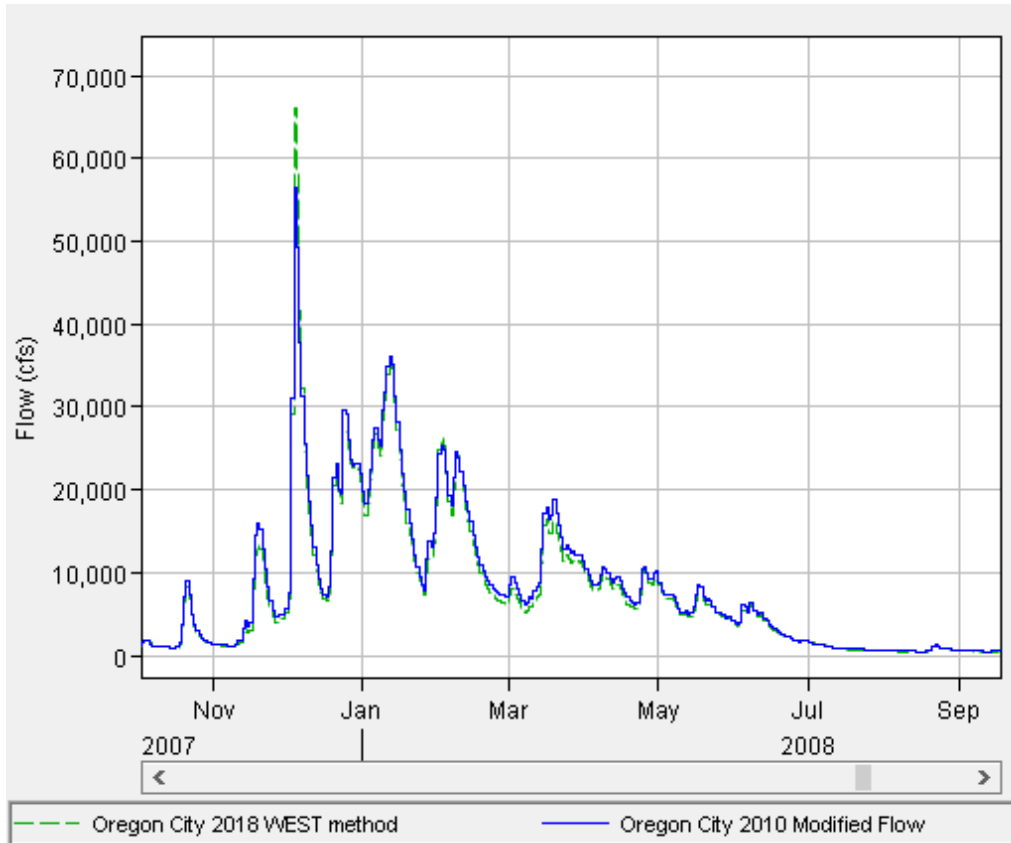

Figure 2-41. Water Year 2009 Comparison at Oregon City, OR.

3 NO-ACTION ALTERNATIVE HEC-RESSIM MODEL

This section documents the HEC-ResSim simulation that is the No-action Alternative (NAA) model for the Willamette Valley System (WVS) Environmental Impact Statement (EIS). The NAA simulation is often referred to as the baseline model because the operation sets used in the simulation model are the same as the operations anticipated for the foreseeable future if no other action is taken.

This section documents the HEC-ResSim program inputs such as reach routing, physical limitations of projects, and the specific operation sets and rules at each of the WVS dams and reservoirs used in the NAA. The modeled alternatives will compare against the NAA to identify changes for the WVS EIS.

3.1 Overview

The U.S. Army Corps of Engineers (USACE), Portland District, owns and operates 13 multi-purpose dams and reservoirs in the Willamette Valley, which are operated as a system and not as independent entities. All projects in the basin share the various functions included in an overall water resources management plan designed to provide flood damage reduction, hydropower generation, irrigation, navigation, recreation, and water quality throughout the basin. This system of reservoirs is modeled in the program HEC-ResSim to define a baseline

*Willamette Valley System Operations and Maintenance
Environmental Impact Statement*

description of the system operation for the WVS EIS. The identification of a baseline is important when assessing alternatives within the EIS as it provides a point of reference for comparison and for weighing potential benefits and impacts of those alternatives. This baseline in the WVS EIS is the NAA. The NAA describes conditions and operations that would likely continue for the foreseeable future if no other action were taken.

USACE developed a routing model of the Willamette River Basin over many years across several projects using the Reservoir System Simulation Program HEC-ResSim. This program was created by the USACE technical center Hydrologic Engineering Center, which is operated within the Institute for Water Resources. The HEC-ResSim software simulates reservoir operations as programmed by the user and is a powerful decision support tool for modelers performing reservoir project studies. The USACE office uses the HEC-ResSim program for many Willamette River Basin studies, adapting the reservoir operation rule sets as needed for each particular study.

The purpose of the NAA simulation is to obtain quantitative results for reservoir operations and regulated streamflow using a formalized set of operational rules for each dam that is used as a proxy for real-time reservoir regulation decisions. Most importantly, the NAA is not meant to reproduce observed data because the model does not take into account any of the special operations, repairs, or forecasting information available to the water management team in real time. Furthermore, the model uses a flow dataset spanning more years than the dams have been in operation. The power of the NAA is that the same set of rules are applied without bias for each year of the flow dataset, providing a spread of regulated streamflow and reservoir levels that generally mimics what could have happened.

The results of the NAA simulation are used to analyze:

- Reservoir storage/elevations
- Reservoir outlet outflows
- Control point flows

These results are the point of reference for comparison to the simulations of all alternatives. This helps the EIS quantify changes that may result if those alternatives are implemented.

The NAA is not a real-time water management tool and does not use forecasts such as the availability of snowpack or inflow predictions from the weather service. In water management at the Portland District, each year has a unique conservation plan developed. In low water years, there are drought contingency plans developed with coordinating agencies. The NAA results will differ more from real-time regulation the drier the year since the program models every day consecutively without the benefit of looking ahead for a whole season.

Figure 3-1 shows the HEC-ResSim network for the WVS EIS NAA, defining the study area. The outlined gray area is the whole Willamette River Basin. The major river of the basin is the Willamette River, which flows northward from the southern end of the basin until it meets the

*Willamette Valley System Operations and Maintenance
Environmental Impact Statement*

Columbia River at its northern end. The HEC-ResSim model includes all 13 of the Corps dams, all river reaches with Corps dams, and selected control points from the southern end of the basin to Oregon City above Willamette Falls (which is the upper-right-most red dot outlined with a white circle). The flow dataset used for the analysis includes all of the surface water from the southern end of the basin to (and including) Oregon City above the Falls. The portion of the Willamette River flowing through Portland, Oregon, is downstream of Willamette Falls and is not included in the reservoir model and neither is any flow coming into the river downstream of Willamette Falls (e.g., the Clackamas River). The Willamette River below the Falls has a tidal influence from the Columbia River that cannot be modeled in HEC-ResSim.

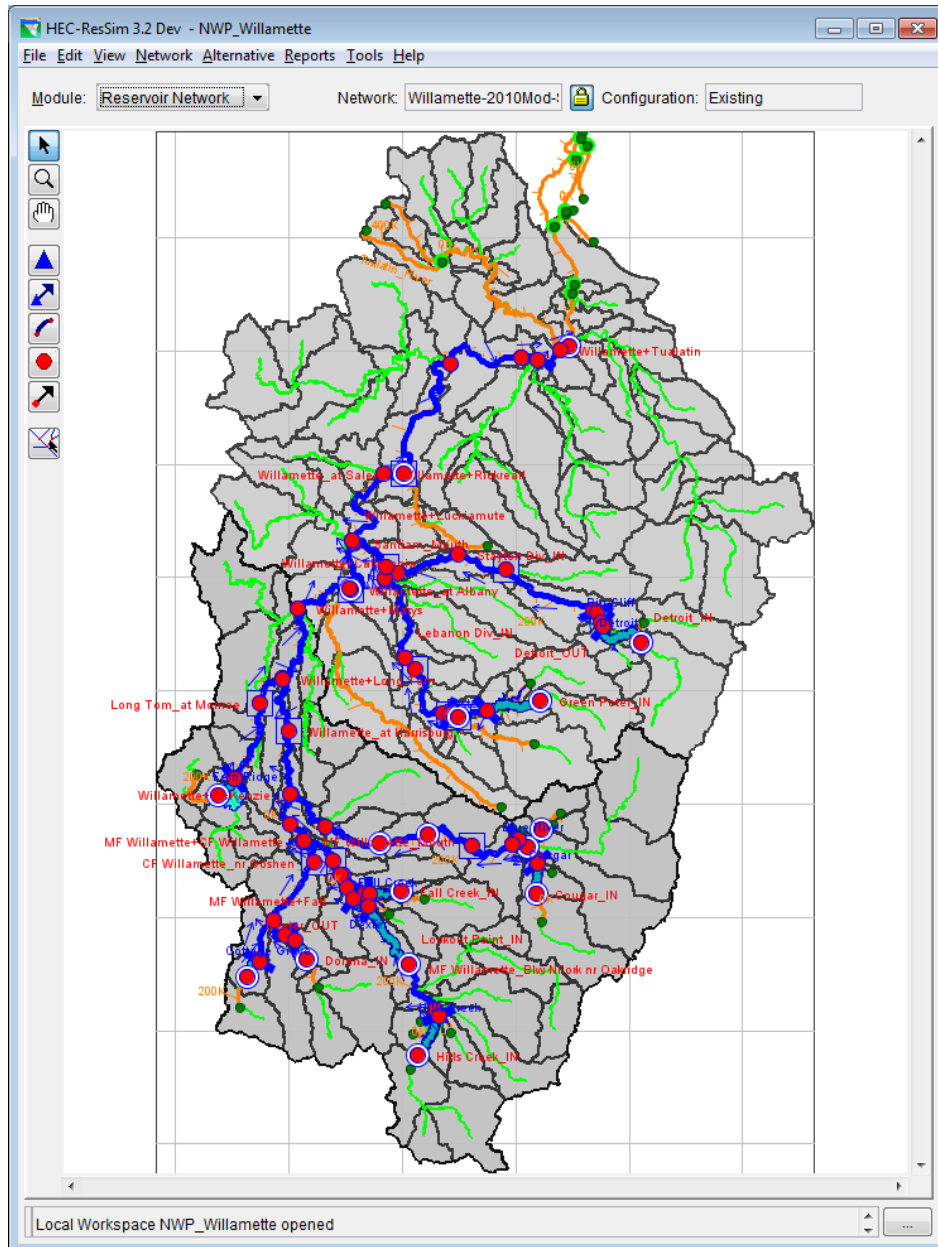

Figure 3-1. HEC-ResSim Network for the NAA Simulation.

*Willamette Valley System Operations and Maintenance
Environmental Impact Statement*

In Figure 3-1, the green and orange lines represent parts of the watershed, which are the fundamental building block of the reservoir model, outlining the streams in the smaller subbasins (green) and the larger streambeds (orange). The green dots represent the calculation points within the watershed. The reservoir network is superimposed over the watershed. In the network image above, the dark blue lines are the river reaches that are analyzed in simulations, and these are superimposed on the orange streamlines of the watershed. Only the river reaches controlled by the USACE dams in the basin are modeled (shown in dark blue), leaving tributaries outside of any USACE control (for example, the Tualatin River and the Calapooia River) as orange lines. A river reach that isn't modeled means that there are no computation points for flow on that reach, though the inflows from those reaches are still included in the flow dataset. The modeled river reaches are connected at junction points (shown as red dots, which are superimposed over some of the green dots), with the red dots outlined by squares representing the control points. Junctions outlined with a white circle have a local inflow component specified in simulations, and junctions with a square around them indicate a location used for downstream flow control in rules. The 13 Corps dams are input as reservoirs and shown as light blue, with the smallest reservoirs (Foster and Big Cliff) not visible at the scale of the figure.

Table 3-1 lists the specifics of the NAA simulation described in this report. The alternative is made of the operation set used for each project, the initial conditions used (the lookback elevations and flows), and the specification of any time series to be used. The simulation is the specified starting and ending dates, the lookback date, the alternative used, and the time step used. Note that the dam and reservoir names in the table below are given by their three letter descriptions used in the Portland District Water Management (DET for Detroit, BCL for Big Cliff, GPR for Green Peter, FOS for Foster, CGR for Cougar, BLU for Blue River, HCR for Hills Creek, LOP for Lookout Point, DEX for Dexter, FAL for Fall Creek, COT for Cottage Grove, DOR for Dorena, and FRN for Fern Ridge).

The lookback flows coincide with the minimum tributary flow of each project for the beginning of October. The outlet for the release corresponds with the release allocation specified in Section 4, Alternative Modeling Assumptions. Lookback flows and elevations are only used when the simulation is initiated.

*Willamette Valley System Operations and Maintenance
Environmental Impact Statement*

Table 3-1. Summary of the Specifics for the NAA Simulation.

Model Parameter	Simulation Parameter
HEC-ResSim Version	HEC-ResSim_3.3.1.124_Dev_Build_64-bit
Watershed	WVP_EIS_21Sep2022
Network	Willamette_EIS_August_2020
Configuration	Existing
Alternative	EIS NAA
Inflow File Name	EISS_1932019_Flows_2020-01-08.dss
Rule Curve File	Willamette_Rule_curves.dss
External Variables File	year_classification.dss, GPR_Min_For_FOS.dss
Simulation Name	EIS_NAA_11May2021
Simulation Start	02Oct 1935 at 2400
Simulation Lookback	01Oct1935 at 2400
Simulation Ending	30Sep 2019 at 2400
Time step	1 day

Table 3-2. No-action Alternative Simulation Start Parameters.

Project	Operation Set	Lookback Elevation	Lookback Flows (cfs)
DET	Willamette EIS – No-action	Rule Curve	Power Plant 1500, Spillway and ROs 0
BCL	Willamette EIS – No-action	1197.0 ft	Power Plant 1200, Spillway 0
GPR	Willamette EIS – No-action	Rule Curve	Power Plant 1500, Spillway and RO 0
FOS	Willamette EIS – No-action	Rule Curve	Power Plant 1500, Spillway 0
CGR	Willamette EIS – No-action	Rule Curve	Power Plant 300, Spillway and RO 0
BLU	Willamette EIS – No-action	Rule Curve	RO 50, Spillway 0
HCR	Willamette EIS – No-action	Rule Curve	Power Plant 400, Spillway and ROs 0
LOP	Willamette EIS – No-action	Rule Curve	Power Plant 1350, Spillway and ROs 0
DEX	Willamette EIS – No-action	693.0 ft	Power Plant 1350, Spillway 0
FAL	Willamette EIS – No-action	Rule Curve	RO 200, Spillway 0
COT	Willamette EIS – No-action	Rule Curve	RO 50, Spillway 0
DOR	Willamette EIS – No-action	Rule Curve	RO 100, Spillway - 0

*Willamette Valley System Operations and Maintenance
Environmental Impact Statement*

Project	Operation Set	Lookback Elevation	Lookback Flows (cfs)
FRN	Willamette EIS – No-action	Rule Curve	RO 30, Spillway and Sluice Gate 0

3.2 The Period of Record in the HEC-ResSim Analysis

This section provides a brief discussion of the flow dataset as used in the model simulation and a discussion of the water year types in this Period of Record (POR), which are designations for wet through dry years made based on spring storage.

3.2.1 Reservoir Inflows

The hydrologic inflow dataset used in the WVS EIS adjusts historical inflows spanning 1935–2019 to reflect 2008 levels of depletion. A detailed description of the development of the inflow dataset is in Section 2, Inflow Dataset.

3.2.2 Water Year Classification

The POR flows span 84 years, which encompass a variety of wet and dry water years. The 2008 Biological Opinion (NMFS 2008) designates four water year classifications that are used to determine the mainstem Willamette River minimum flow targets for April through October. The four classifications are Abundant, Adequate, Insufficient, and Deficit. The Insufficient and Deficit water years have reduced minimum flow targets at Salem and Albany, with the Deficit year targets less than the Insufficient year targets during some, but not all, months. Table 3-3 lists these mainstem targets by water year type.

*Willamette Valley System Operations and Maintenance
Environmental Impact Statement*

Table 3-3. Mainstem Biological Opinion Flow Targets for Salem and Albany.

Calendar Date	Abundant and Adequate at Albany	Insufficient at Albany	Deficit at Albany	Abundant and Adequate at Salem	Insufficient at Salem	Deficit at Salem
01 - 30 April	--	--	--	17,800	Interpolated	15,000
01 - 31 May	--	--	--	15,000	Interpolated	15,000
01 - 15 June	4,500	4,500	4,000	13,000	Interpolated	11,000
16 - 30 June	4,500	4,500	4,000	8,700	Interpolated	5,500
01 - 31 July	4,500	4,500	4,000	6,000	Interpolated	5,000
01 - 15 August	5,000	4,500	4,000	6,000	Interpolated	5,000
16 - 31 August	5,000	4,500	4,000	6,500	Interpolated	5,000
01 - 30 September	5,000	4,500	4,000	7,000	Interpolated	5,000
01 - 31 October	5,000	4,500	4,000	7,000	Interpolated	5,000

The year classification is based on the storage volume targets of the Federal projects in the Willamette River Basin for each day of May 10 through 20 of any year. The storage volume is determined by summing the conservation pool storage in all the reservoirs (not counting the re-regulating dams Big Cliff and Dexter). The peak composite system conservation storage occurring May 10 through 20 of each year is used to classify the water year type. Table 3-4 has the water years type definitions and Figure 3-2 shows how those definitions fit within the water management year in the Willamette River Basin. The maximum useable conservation storage is 1.59 million acre-feet (MAF).

Table 3-4. Definition of Water Year Types in the Willamette River Basin.

Water Year Type	Total Willamette Conservation Storage between May 10 and 20
Abundant	Greater than 1.48 Maf
Adequate	Between 1.20 and 1.48 Maf
Insufficient	Between 0.90 and 1.20 Maf
Deficit	Less than 0.90 Maf

*Willamette Valley System Operations and Maintenance
Environmental Impact Statement*

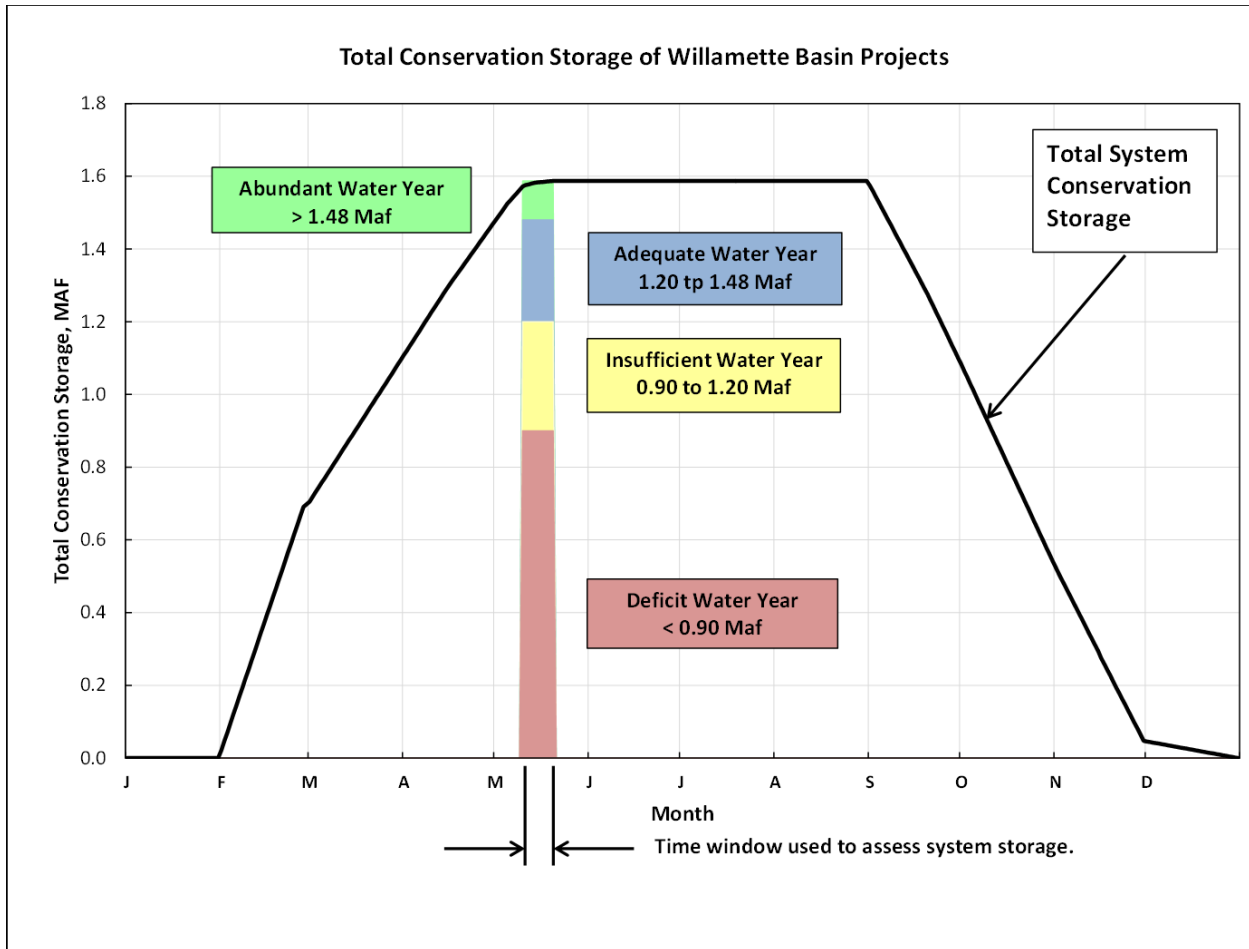

Figure 3-2. Total Conservation Storage in the Willamette River Basin USACE Dams and Reservoirs, by Date and Graphical Water Year Type Definition.

The year types for the POR were determined by running a preliminary (first pass) simulation with water year designations used in the Willamette Basin Review (USACE 2019) NAA and operations designated for the WVS EIS and then adjusting water year designations based on that simulation’s maximum storage for the period May 10–20.

A simulation was run with all projects using Salem minimum flow targets for the Abundant/Adequate year, and storage volumes for May 10–20 were calculated for each year.

These water year classifications are shown in Table 3-5. The designation is only of use during the period of April through October and is not used during the fall and winter. The designation is by calendar year, not water year. October’s flow targets are based on the previous May storage volumes. The water year classifications shown in Table 3-5 were entered into HEC-DSS as a time series and used in the model as an external variable for Salem and Albany minimum flow rules.

Table 3-5. Water Year Types for 1936–2019 and Maximum Conservation Storage Value for May 10–20, in Millions of Acre-Feet (MaF).

Year	Water Year Type	Storage, MaF
1936	Abundant	1.58
1937	Abundant	1.59
1938	Abundant	1.58
1939	Adequate	1.35
1940	Adequate	1.31
1941	Deficit	0.36
1942	Deficit	0.74
1943	Abundant	1.58
1944	Insufficient	1.06
1945	Abundant	1.59
1946	Adequate	1.47
1947	Adequate	1.4
1948	Abundant	1.59
1949	Abundant	1.57
1950	Abundant	1.59
1951	Abundant	1.57
1952	Abundant	1.57
1953	Abundant	1.56
1954	Adequate	1.43
1955	Abundant	1.55
1956	Abundant	1.59
1957	Abundant	1.54
1958	Abundant	1.52
1959	Adequate	1.42
1960	Abundant	1.59
1961	Abundant	1.56
1962	Abundant	1.58
1963	Abundant	1.58
1964	Adequate	1.38
1965	Insufficient	1.13
1966	Adequate	1.45
1967	Insufficient	1.13
1968	Insufficient	0.95
1969	Abundant	1.58
1970	Adequate	1.4
1971	Abundant	1.59
1972	Abundant	1.59

*Willamette Valley System Operations and Maintenance
Environmental Impact Statement*

Year	Water Year Type	Storage, MaF
1973	Deficit	0.72
1974	Abundant	1.58
1975	Abundant	1.58
1976	Abundant	1.58
1977	Deficit	0.89
1978	Insufficient	0.96
1979	Abundant	1.58
1980	Adequate	1.25
1981	Adequate	1.22
1982	Abundant	1.57
1983	Abundant	1.56
1984	Abundant	1.59
1985	Adequate	1.43
1986	Adequate	1.43
1987	Insufficient	0.96
1988	Abundant	1.57
1989	Abundant	1.52
1990	Adequate	1.41
1991	Abundant	1.53
1992	Insufficient	0.96
1993	Abundant	1.59
1994	Insufficient	0.93
1995	Abundant	1.58
1996	Abundant	1.59
1997	Abundant	1.58
1998	Adequate	1.44
1999	Abundant	1.59
2000	Abundant	1.59
2001	Insufficient	0.92
2002	Adequate	1.44
2003	Abundant	1.57
2004	Adequate	1.28
2005	Adequate	1.22
2006	Adequate	1.4
2007	Adequate	1.42
2008	Abundant	1.59
2009	Abundant	1.59
2010	Adequate	1.38
2011	Abundant	1.59
2012	Abundant	1.58

*Willamette Valley System Operations and Maintenance
Environmental Impact Statement*

Year	Water Year Type	Storage, MaF
2013	Adequate	1.3
2014	Abundant	1.59
2015	Deficit	0.56
2016	Adequate	1.36
2017	Abundant	1.59
2018	Adequate	1.33
2019	Adequate	1.45

3.3 HEC-ResSim Network and Dam Specifics

The reservoir simulation program HEC-ResSim requires input at the network level, which is information about the rivers, streams, and the physical parameters related to the dams that are modeled. This section describes the configuration, routing reaches, and dam physical parameters used in the NAA simulation for the WVS EIS.

3.3.1 Configuration in HEC-ResSim

The Configuration in HEC-ResSim is a specific physical arrangement of dams and reservoirs and computation points modeled in the Watershed. The Configuration used in the Willamette River Basin model is called “Existing,” and it is the only configuration in the model.

3.3.2 Routing Reaches

The river reaches analyzed in the HEC-ResSim model (the dark blue lines in Figure 3-1) have a routing associated with them, which the program uses to determine how fast the water will pass through that section of a river. A reach with “null” routing will pass the water through instantaneously, while a reach with routing will have a calculated flow change. The HEC-ResSim model is set to be as close to the routings used for the 2010 Modified Flow development as possible, which largely uses the Streamflow Synthesis and Reservoir Regulation (SSARR) routing method (see USACE 1991). The SSARR routing was a method developed for the Pacific Northwest in the 1960s for the HEC-5 model (a precursor to HEC-ResSim) for the Willamette River Basin. The SSARR routing is based on a timing equation, $TS = KTS/Q^n$, where the time of storage in the reach is TS, Q is the flow, and KTS and n are parameters determined through hydrologic analyses. Note that the actual length of the reach is not in the equation—the travel time of water down a tributary stream can be applied to any single reach of the tributary, with the remaining reaches in the tributary given null routings. The schematic shown in Figure 3-3 illustrates the above description.

*Willamette Valley System Operations and Maintenance
Environmental Impact Statement*

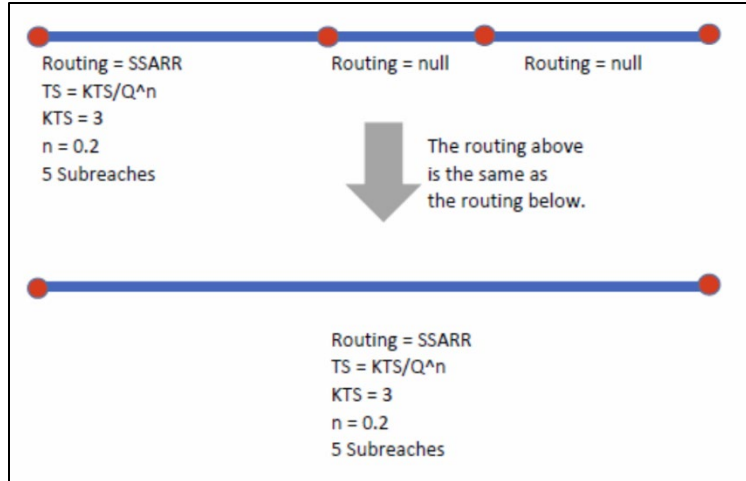

Figure 3-3. Schematic of SSARR Routing Applied to a Portion of a Stream.

Most of the reaches in the HEC-ResSim network are given null routings, with those reaches not specified as “null” shown in Table 3-6. The lettered sub-tables A to E show those reaches designated by interpolation rather than the KTS/Q^n equation.

Table 3-6. SSARR Routing Specifications.

Reach Name	KTS	n	# Sub-reaches
CF Willamette+Row to CF Willamette_nr Goshen	10	0.2	4
Lebanon Div_IN to So Santiam_Mouth	5	0.2	5
Long Tom_nr Alvadore to Long Tom_at Monroe	5	0.2	5
MF Willamette+CF Willamette to Willamette_at Eugene	3	0.2	5
MF Willamette+Fall to MF Willamette_at Jasper	3	0.2	5
MF Willamette_abv Salt Cr nr Oakridge to MF Willamette_Blw NFork	1.5	0.1	2
McKenzie+Blue to McKenzie_at Vida	4	0.1	2
No Santiam_at Niagara to No Santiam_at Mehama	4	0.2	5
So Santiam_nr Foster to So Santiam_at Waterloo	3.5	0.2	5
Stayton Div_IN to Greens Bridge NR Jefferson	7	0.2	5
Willamette+McKenzie to Willamette_at Harrisburg	Table A	Table A	7
Willamette+Long Tom to Willamette+Marys	Table B	Table B	6
Willamette+Luckiamute to Willamette+Rickreall	Table C	Table C	6
Willamette+Marys to Willamette+Calapooia	Table D	Table D	5
Willamette+Mill to Willamette+Yamhill	Table E	Table E	2

*Willamette Valley System Operations and Maintenance
Environmental Impact Statement*

SSARR routings interpolation sub-tables:

Table A

Outflow, cfs	Storage, hours
1	2.30
1,000	1.40
20,000	0.57
30,000	0.57
40,000	0.71
50,000	0.89
60,000	1.14
80,000	1.14
140,000	0.83
180,000	0.71

Table B

Outflow, cfs	Storage, hours
1	4.00
1,000	3.33
10,000	2.16
20,000	1.83
30,000	1.83
40,000	2.08
50,000	2.67
60,000	3.34
70,000	3.66
80,000	3.58
100,000	3.16
120,000	2.80
180,000	1.83

*Willamette Valley System Operations and Maintenance
Environmental Impact Statement*

Table C

Outflow, cfs	Storage, hours
1,000	3.33
10,000	2.67
20,000	2.17
30,000	1.58
40,000	1.42
50,000	1.17
60,000	1.28
80,000	1.42
100,000	2.26
120,000	2.75
140,000	3.00
170,000	3.08
200,000	2.84
250,000	2.16
300,000	1.83
400,000	1.75
500,000	1.66

Table D

Outflow, cfs	Storage, hours
1	2.94
1,000	2.40
3,000	1.96
10,000	1.40
20,000	0.80
30,000	0.60
40,000	0.52
50,000	0.52
60,000	0.60
80,000	0.70
100,000	0.85
120,000	1.00
150,000	1.20
200,000	1.40
300,000	1.30
400,000	1.12
500,000	1.00

*Willamette Valley System Operations and Maintenance
Environmental Impact Statement*

Table E

Outflow, cfs	Storage, hours
1	0.40
50,000	0.48
100,000	0.71
150,000	1.12
200,000	1.54
250,000	1.85
300,000	2.10
350,000	2.31
400,000	2.50
500,000	2.65

3.3.3 HEC-ResSim Inputs for Physical Parameters of Each Dam

All 13 USACE dams in the Willamette River Basin are modeled in HEC-ResSim. The 13 dams and reservoirs comprise 11 storage dams and reservoirs and 2 re-regulation dams and reservoirs. The dams and reservoirs are configured with a variety of outlet types, such as turbines, regulating outlets, and spillways, which can be either gated or uncontrolled. The physical parameters of individual outlets in HEC-ResSim for the NAA will remain the same for all alternatives evaluated. Rating curves for individual outlets are provided in each reservoir's respective USACE Water Control Manual (WCM).

The following is a list of the USACE dams and reservoirs in the Willamette River Basin and their type:

Project	Type of Reservoir	Abbreviation
Big Cliff	Re-regulation	BCL
Detroit	Storage	DET
Green Peter	Storage	GPR
Foster	Storage	FOS
Cougar	Storage	CGR
Blue River	Storage	BLU
Hills Creek	Storage	HCR
Lookout Point	Storage	LOP
Dexter	Re-regulation	DEX
Fall Creek	Storage	FAL
Dorena	Storage	DOR
Cottage Grove	Storage	COT
Fern Ridge	Storage	FRN

*Willamette Valley System Operations and Maintenance
Environmental Impact Statement*

Table 3-7 shows the number of outlets that each dam has of each type. Table 3-8, Top of WVS Dams' Elevation and Length, also lists the top of dam elevation in feet (in the NGVD29 datum) that is used in HEC-ResSim and the length of the dam that is used in HEC-ResSim.

Table 3-7. Summary of Outlets by Project.

Project	Turbines	Regulating Outlets	Gated Spillway Bays	Uncontrolled Spillway
Hills Creek	2	2	3	-
Lookout Point	3	4	5	-
Dexter	1	-	7	-
Fall Creek ¹	-	2	2	-
Cottage Grove	-	3	-	1
Dorena	-	5	-	1
Cougar	2	2	2	-
Blue River	-	2	2	-
Fern Ridge ²	-	5	6	-
Green Peter	2	2	2	-
Foster	2	-	4	-
Detroit ³	2	4	6	-
Big Cliff	1	-	3	-

¹Fall Creek Dam has a special outflow structure collectively called the fish horns. HEC-ResSim models fish horn flow as going over the spillway.

²Fern Ridge Dam has four sliding gate regulating outlets and one sluice gate.

³Detroit Dam has two upper controlled outlets and two lower controlled outlets. The lower controlled outlets are not modeled because they are not used.

Table 3-8. Top of WVS Dams' Elevation (ft, NGVD) and Length (ft).

Project	Elevation	Length
Hills Creek	1,548.0	2,235.0
Lookout Point	941.0	2,840.0
Dexter	235.0	2,765.0
Fall Creek	839.0	5,100.0
Cottage Grove	808.0	1,846.0
Dorena	865.7	2,800.0
Cougar	1,705.0	1,500.0
Blue River	1,362.0	1,250.0
Fern Ridge	379.5	6,320.0
Green Peter	1,020.0	1,380.0
Foster	646.0	4,800.0
Detroit	1,579.0	1,523.2
Big Cliff	1,210.0	295.0

3.3.4 Water Withdrawals and Returns

The WVS EIS hydrologic inflow data set is adjusted to represent 2008 levels of irrigation using assumed irrigation demands predicted by the 2010 Modified Flows study discussed in Section 2.4.4, Withdrawals. Withdrawals were added to account for increases in withdrawals between 2008 and 2050 (projected). These increases are documented in Appendix J.

3.4 HEC-ResSim Network and Dam Specifics

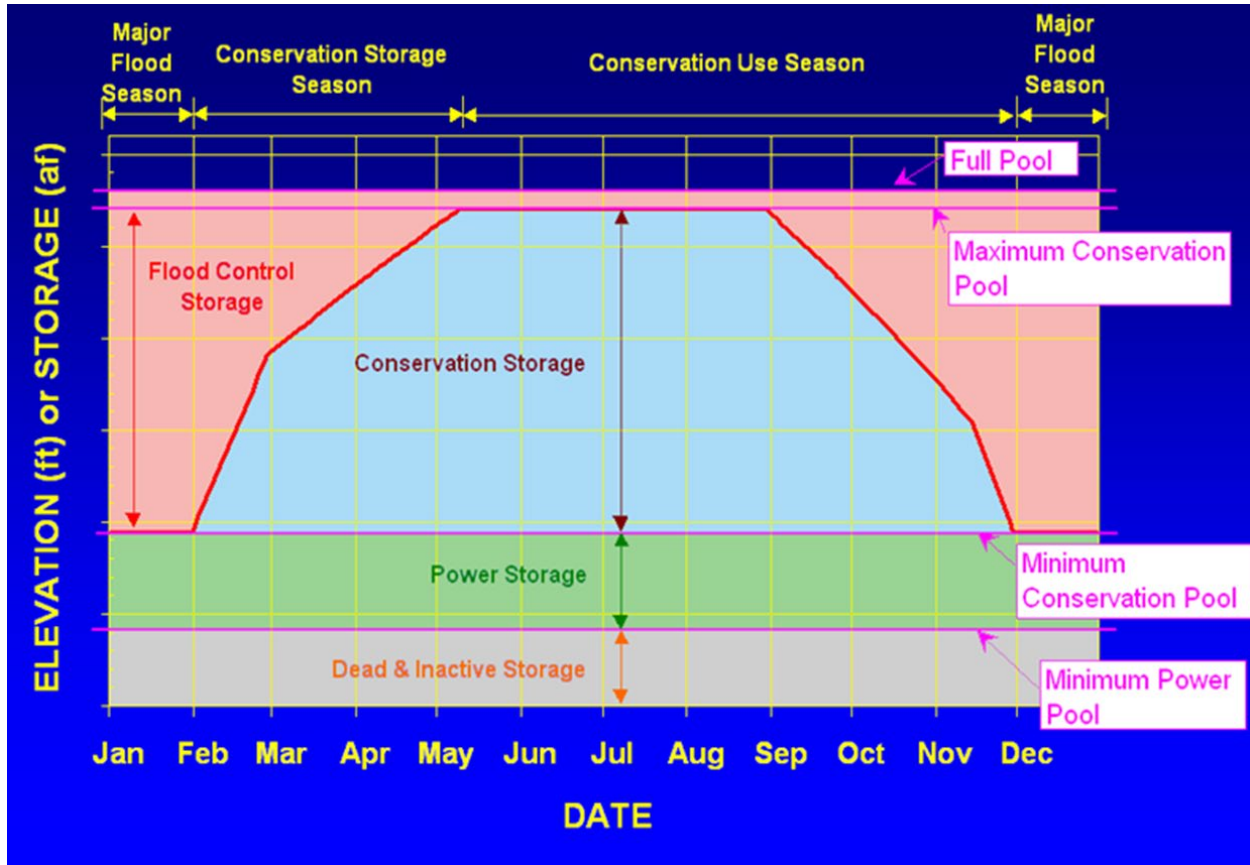

Figure 3-4. Generic Storage Graph of a Willamette Dam and Reservoir. Note the rule curve, the heavy red line, is shaped slightly differently for each project, and refill and draft schedules also vary by project. Projects without a powerhouse do not have a power pool, shown in green in the graph.

The NAA HEC-ResSim simulation for the flow dataset period of record contains an operation set of rules for each of the 11 storage projects that is intended to mimic the general way that reservoir regulation occurs in the Willamette River Basin. The operation sets were not written to account for any forecasting or agency coordination efforts that occur in real-time water management decisions, but rather seek to implement a consistent approach to the reservoir operations over all years of the record. This consistent approach means that the reservoirs store water when necessary for flood risk management, release stored water from flood events according to the water control manuals, refill according to the rule curves when inflows are high enough, supplement mainstem minimum flows, reduce releases to reserve water for later use in the season when pool levels are too far below rule curve, supply minimum tributary flows, and account for physical limitations of dam outlets.

The remainder of this section covers some of the basic operations and rules that are used at multiple projects in the NAA simulation, while the project-specific rules are described individually in Section 3.5, Project Specified Modeled Operations, for each specific dam. Most of

*Willamette Valley System Operations and Maintenance
Environmental Impact Statement*

the particulars described in this section will also be part of the alternatives evaluated for the WVS EIS. Below is a brief outline of the information covered in this section and a note on how the WVS EIS alternatives would use this information:

- Reservoir zones and rule curves: the zones and guide curve to operate a project are defined in the operation set, and all alternatives in the WVS EIS analyses will have these zones, although target elevations defined by the rule curve may differ and additional zones may be added when modeling alternatives.
- Re-regulation dams (Big Cliff and Dexter): these dams are treated the same in all WVS EIS action alternatives as they are in the NAA simulation. No operations are defined for these reservoirs. They pass flow from the reservoir above them on a daily timestep as is generally the case in actual operations.
- Release allocations: the release allocation, which specifies the preferred order of outlet use for a dam, is part of the operation set. In general, the penstock is used first, followed by the regulating outlet when the penstock capacity is exceeded, and the spillway lastly when the combined penstock and regulating outlet capacity is exceeded. Spill operations to manage temperatures or encourage volitional fish passage requiring a different release allocation are modeled in HEC-ResSim at Foster Dam and Reservoir and a spill allocation is post-processed into results at Detroit Dam and Reservoir in the NAA. Release allocations in other alternatives are modeled in HEC-ResSim when feasible and may otherwise be post processed outside of HEC-ResSim. HEC-ResSim modeling of minimum gate openings at low releases is coarse.
- Regulating outlet capacities and minimum gate openings: All WVS EIS alternatives will adhere to the same physical outlet capacity constraints.
- Induced Surcharge Rules: these rules govern the release of water in special cases to prevent dam overtopping. These rules do not change among any of the operation sets for WVS EIS alternatives.
- Downstream Control Points, Maximum Flow Rules: Maximum flow rules are related to the flood risk management function of the dams. The same maximum flow rules for downstream control points apply to all WVS EIS alternatives.
- Downstream Control Point minimum and maximum NMFS 2008 Biological Opinion Flow Rules: Biological Opinion minimum and maximum flow rules on tributaries and on the mainstem of the Willamette River at Albany and Salem may change for an alternative to evaluate the effects of a possible change to these targets.
- Maximum and minimum Biological Opinion rates of flow changes are the same for all WVS EIS action alternatives as they are in the NAA. These flow changes are also described as ramping rates.
- Interim Risk Reduction Measures (IRRM).

3.4.1 Reservoir Zones in HEC-ResSim and Rules Curves

The WVS reservoirs are divided into zones where specific rules can be applied. The rules for a specific zone are applied when the modeled reservoir elevation is at or below that zone. Table 3-9 and Figure 3-5 identify and describe these zones.

Table 3-9. Zone Types Used in Operation Sets.

Zone Name	Significance
Top of Dam	The physical top of dam where overtopping would occur.
Flood Control	Max pool available for flood control.
50% FC Pool* Primary Flood Control* Secondary Flood Control*	Used to separate the flood control storage into different types of flood control operations at some dams and reservoirs: normal release rules and aggressive release rules which let out additional water when storage space becomes limited.
Conservation	The “Guide Curve” that coincides with the project rule curve. (HEC-ResSim uses the zone defined as the Guide Curve as the preferential pool elevation for a project to be.)
Buffer	Acts like an interim draft limit to prevent the pool from drafting too rapidly and is used to help mimic reservoir regulation under drought conditions.
Inactive	The lowest zone in the operation set, and is a zone required by the program. No rules can be applied in this zone.

* Not used for all projects

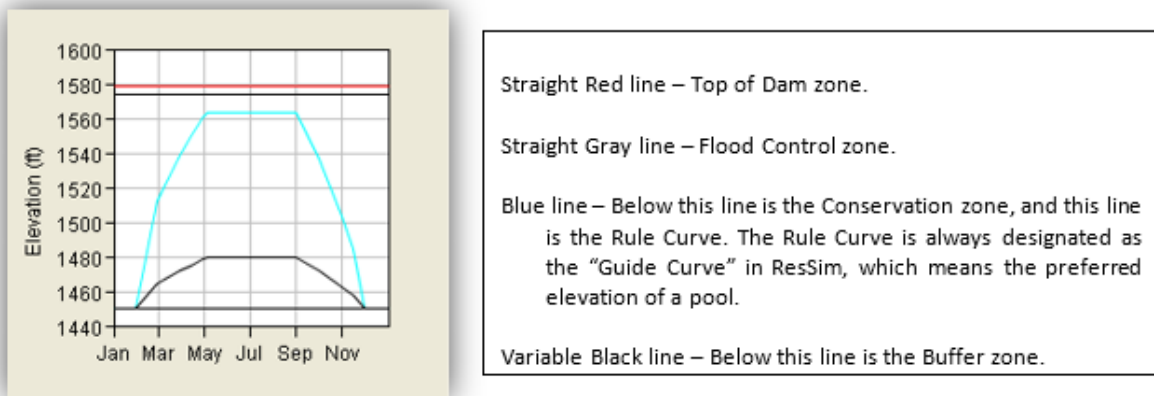

Figure 3-5. Typical Example Graph of Reservoir Zones.

Inactive Zones. The HEC-ResSim program has a special zone required in each reservoir called the inactive zone, with the program controlling even the name of this zone. This zone was programmed internally to HEC-ResSim to represent the pool elevation below which no water can leave the dam, or the elevation just below the lowest outlet, representing the dead storage

of the project. The program does not allow any rules to be input to this zone because it is supposed to be unable to let flow out.

In practice, a modeler can define the inactive zone at any elevation, although no rules will be able to be applied and no zone can be defined below it. In the NAA model, the inactive zone is specified as the elevation of the Minimum Conservation Pool because the Corps is generally not authorized to use the stored water below this level. At dams and reservoirs with power generation, water between this level and the Minimum Power Pool is reserved for use during power emergencies called by BPA in the NAA. During real-time operations in very dry conditions with pool levels at the minimum conservation pool, the Corps and BPA will often agree to release water from these projects without a power emergency, dropping into the power pool rather than letting a river dry up.

The inactive zone has another use within the program, which is to be the lower boundary for implicit storage calculations. Implicit storage is used for projects that operate for a downstream minimum flow so that the flow contribution or share of that target flow can be calculated.

When the program calculates that a reservoir pool level has dropped to the elevation of the inactive zone, it will still release from the reservoir if an outlet has capacity at that elevation. The outlet chosen by the program is based on the release allocation and the physical capacity, but the flow level it calculates to pass is either the last minimum from the zone above or passing inflow, whichever is less. Once the inflow exceeds the last minimum outflow rule long enough to accumulate storage, the pool level raises to the zone above the inactive zone, and then the program starts following that zone's rule set.

3.4.2 Re-regulating Dams

There are two dams in the Willamette River Basin that are re-regulation projects—Big Cliff and Dexter Dams. They are modeled in HEC-ResSim only with zones and no rules. Both have a Top of Dam, Flood Control, Conservation, Buffer, and Inactive zones, with the Conservation zone specified as the Guide Curve. All zones are given a constant elevation through the year because these two projects do not have rule curves. No rules are included. These dams have only a small amount of storage, and on a daily average, do not accumulate water or pass more than comes in. The NAA model data is being used to assess statistical data with a daily time step for 84 years, so more detailed modeling at these projects is not necessary for the results needed.

3.4.3 Release Allocations

Each operation set in HEC-ResSim has an associated release allocation that specifies the priority of use of each dam outlet. Table 3-10 shows the release outlet allocation used for each project, with the flow passing through turbines as first priority at power projects. Some projects have rules that adjust the chosen outlet for certain situations, but unless otherwise specified, the program follows the release order shown here in the NAA. Release allocations for other alternatives that differ from what is shown in Table 3-10 will be modeled in HEC-ResSim when feasible, but complex flow reallocations will be post-processed outside of HEC-ResSim.

Table 3-10. Sequential Release Allocation for All Model Runs.

Project	Allocation Type and Order	Project	Allocation Type and Order
DET	Power Plant	HCR	Power Plant
	Upper Controlled Outlet		Regulated Outlet
	Spillway		Spillway
BCL	Power Plant	LOP	Power Plant
	Spillway		Regulated Outlet
GPR	Power Plant		Spillway
	Controlled Outlet	DEX	Power Plant
	Spillway		Spillway
FOS	Power Plant	FAL	Regulated Outlet
	Spillway		Spillway
CGR	Power Plant	DOR	Regulated Outlet
	Regulating Outlet		Uncontrolled Outlet
	Spillway	COT	Regulated Outlet
BLU	Regulating Outlet		Uncontrolled Outlet
	Spillway	FRN	Regulated Outlet
			Spillway
			Sluice Gate

*Detroit and Foster Dams and Reservoirs have modified release allocations to manage temperature in the NAA.

3.4.4 Capacities and Minimum Gate Openings

Some of the WVS dams and reservoirs with regulating outlets are operated with minimum gate opening—in other words, if a regulating outlet is going to be used, it must open a minimum amount. The flow out of a regulating outlet with a specific gate opening is a function of the pool elevation, as the amount of head affects the outflow. Many of the dams have controlled outlet physical parameter capacities with zeros for small gate openings in an attempt to model this gate opening restriction; however, in simulations, HEC-ResSim will interpolate between a zero outflow at one gate opening and the outflow it computes as necessary with the next higher gate opening, regardless of how small of an increment the gate opening specifies. If the smallest gate opening included in the capacity table is the minimum opening, the simulation can still interpolate to less than that.

The minimum gate opening rules do not apply to Detroit and Lookout Point Dams because there are re-regulation dams just downstream of these projects. For example, in each day during real project operations, a Detroit Dam regulating outlet might be opened the minimum amount for a few hours, then closed, and perhaps reopened the minimum amount more times. The average regulating outlet flow for the day at Detroit Dam and Reservoir can be less than the minimum required, representing an open gate period for part of the day and a closed gate period for part of the day. The downstream re-regulation dam, Big Cliff, will smooth the flows out over the day. Green Peter Dam does not need the minimum gate opening rule either

because Foster Dam also acts as a re-regulation dam on a daily average. Note that Big Cliff, Dexter, and Foster Dams do not have regulating outlets.

Blue River, Cottage Grove, Dorena, Fall Creek, and Fern Ridge Dams are not operated with minimum gate openings for the regulating outlets. Two dams that are operated with minimum gate openings for the regulating outlet are Cougar and Hills Creek, and both dams have these minimum regulating outlet gate openings modeled in the same way.

Cougar and Hills Creek Dams each have an IF BLOCK to determine if the current time step has calculated regulating outlet flow at the dam. If not, nothing changes, and no ELSE or ELSE IF is needed. If the current time step does have regulating outlet flow at the project, it is required to meet the minimum flow given in the rule within the IF BLOCK. The minimum regulating outlet flows listed in the rule are the one regulating outlet capacity by reservoir pool level for the minimum gate opening.

Dexter and Big Cliff Dams have minimum flow requirements for their penstocks. These are accounted for in the minimum flow rules for the upstream dams instead of a minimum gate opening. This works in the model because the penstock is the first outlet to release.

3.4.5 Induced Surcharge

Induced Surcharge Rules. The induced surcharge rule available in HEC-ResSim is one that specifies a total flow out of the project based on the pool elevation and the inflow to the reservoir. The purpose of this type of operation is to carefully control the rate of fill as the reservoir gets close to full to still reduce the regulated downstream peak, but also protect the project from overtopping. This type of operation is rare because the storage available at each project is usually sufficient to capture large inflow events in the flood season. The Willamette Valley storage reservoirs each have an induced surcharge operation described in their WCM.

The induced surcharge function is difficult to model for a daily time step. The special flood regulation curves shown in the project WCMs are smoothly varying functions of inflow, with the release changing as the inflow changes. With a daily time step, the inflow peak is flattened and widened, and the rule is either applied all day or not at all. Each dam's induced surcharge rule is defined in the individual dam sections. This rule is used because the flow dataset POR runs continuously from 01Oct1935 through to 30Sep2019 and contains all the flood events in that record. The model configuration used is not suitable for assessing impacts to flood risk beyond a screening level analysis.

3.4.6 Downstream Control Points, Maximum Flow Rules

Flood risk management is the primary authorized purpose of the WVS dams, and to accomplish this task, each dam in the WVS regulates its outflow based on at least one control point downstream. This regulation is accomplished by the project storing inflows and reducing outflows either when the downstream control point flows are too high or to assist in keeping

the downstream flows as low as possible. The downstream control points and flow levels for regulation are illustrated in the schematic of Figure 3-6.

The blue triangles in the schematic of Figure 3-6 are the control points for reservoir regulation. Each control point has two key regulation thresholds: bankfull and flood stage, which are labeled as “BF” and “FS,” respectively, in the figure. Each of the control points has a stream gage that is used for reservoir regulation. Other gages in the basin provide additional information to regulators during real time operation, and these gages are shown in the figure as either circles or diamonds. For reservoir operation modeling for Willamette River Basin studies, only the control points (the locations marked with the blue triangles) are included in HEC-ResSim.

Typically, dams and reservoirs are operated to maintain flows below bankfull level of a downstream control point whenever possible and when there is ample space in the reservoir to store inflows. Bankfull is considered a non-damaging level of flow at that location. In larger flood events, which have high local flow components, dams and reservoirs are operated to maintain control points below flood stage whenever possible. The goal of the reservoir regulation is to not make the flooding worse downstream. In all cases, each dam must release its minimum required outflow, but increased releases from those minimums use the flow at the control points to guide the regulation.

These downstream control point flow level operations are modeled in HEC-ResSim as maximum downstream rules. A downstream maximum rule is used by HEC-ResSim to calculate a project outflow that does not exceed the maximum level specified in the rule.

The WVS dams and reservoirs are operated as a system for flood control. All key control points on each tributary (Vida, Jasper, Goshen, Monroe, Waterloo, Mehama, and Jefferson) are regulated by the appropriate project upstream in the model. For mainstem control points, the southern dams and reservoirs are operated for a common bottleneck point, Harrisburg, and the northern Santiam dams and reservoirs are used to reduce flows at Salem. By reducing for Harrisburg, the southern projects also reduce Albany and Salem flows. Table 3-11 summarizes which projects are used to reduce stages at each control point.

A dam and reservoir cannot always be operated to meet a bankfull goal at a control point. If the reservoir is getting full, the downstream control point goal may be higher in order to slow the rate of fill. The goal then would be to not exceed flood stage, and these rules would be used at higher reservoir elevations than the bankfull rules. These two types of downstream maximum rules are summarized below by control point. Note that Hills Creek Dam and Reservoir is modeled as a tandem operation with Lookout Point Dam and Reservoir, rather than a specific downstream rule, so if Lookout Point stores for downstream control points, then Hills Creek adjusts to balance the storage between itself and Lookout Point, effectively reducing flows to help control downstream flows.

The downstream maximum rules are in effect year-round, but typically only govern the HEC-ResSim program decision-making during a winter flood event. Smaller flood events may occur

*Willamette Valley System Operations and Maintenance
Environmental Impact Statement*

during the spring refill season or late in the drafting season as well and need some regulation to manage. The WVS EIS HEC-ResSim watershed prioritizes model stability during the conservation season above accurate regulation of flood events, which influences the choice of downstream regulation goals. The model results should not be used beyond screening level analysis to evaluate flood risk.

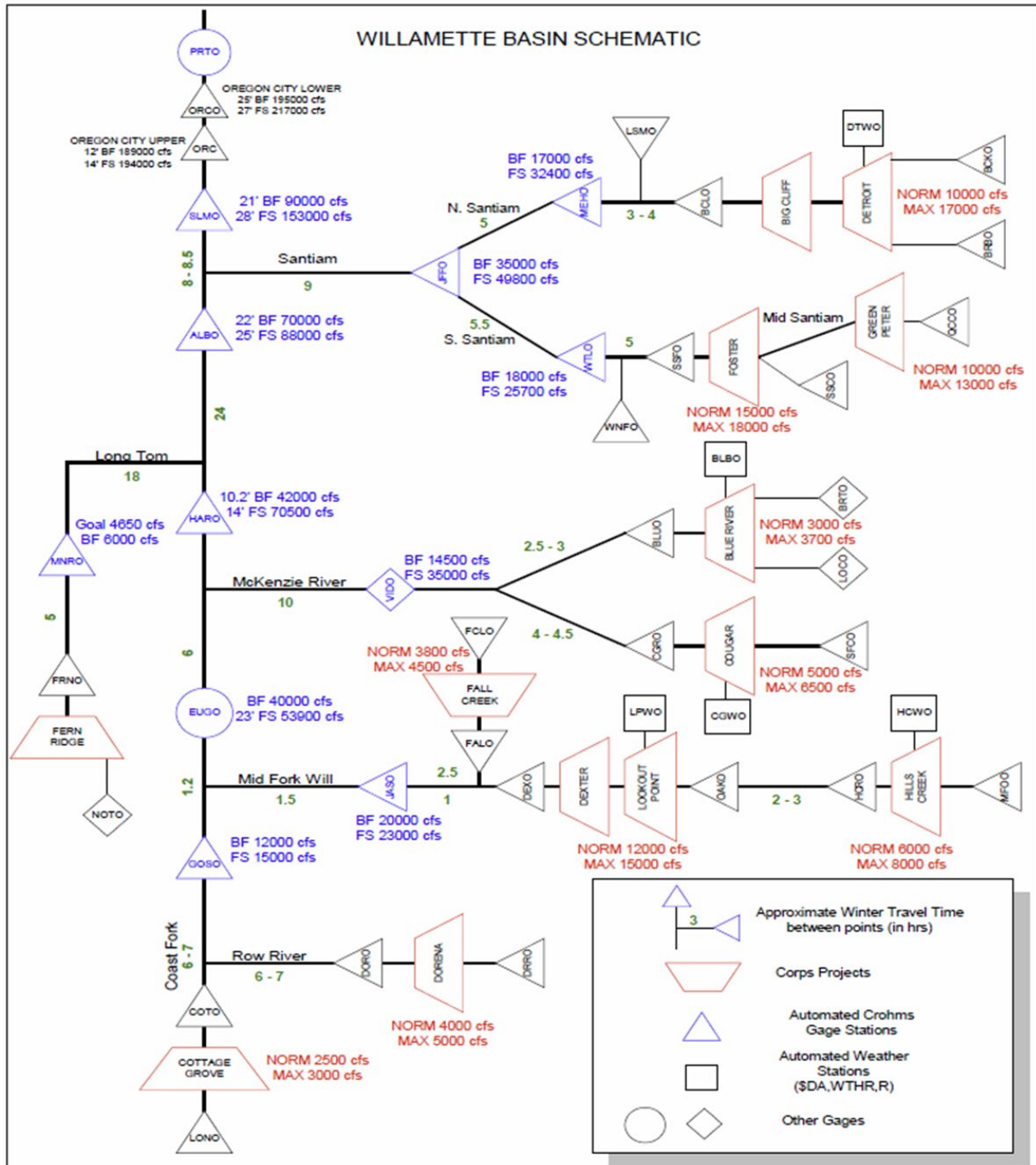

Figure 3-6. Willamette River Basin Schematic.

*Willamette Valley System Operations and Maintenance
Environmental Impact Statement*

Table 3-11. Project Operation for Control Point Maximum Flows.

Control Point	Hills Creek	Lookout Point	Fall Creek	Cottage Grove	Dorena	Cougar	Blue River	Fern Ridge	Green Peter	Foster	Detroit
Jasper	x	√	√								
Goshen				√	√						
Vida						√	√				
Harrisburg	x	√	√	√	√	x	x				
Monroe								√			
Albany	x	x	x	x	x	x	x	x			
Waterloo									√	x	
Mehama											√
Jefferson									√	x	√
Salem	x	x	x	x	x	x	x	x	√	x	√

√ Project uses HEC-ResSim rules to reduce stages at the downstream control point.

x Project does not use a specific HEC-ResSim rule to reduce stages at the downstream control point, but reductions upstream do translate to reduced flows at these control points.

Screen shots of these downstream maximum rules are shown in Figure 3-7 and Figure 3-8.

*Willamette Valley System Operations and Maintenance
Environmental Impact Statement*

Goshen Bankfull Max

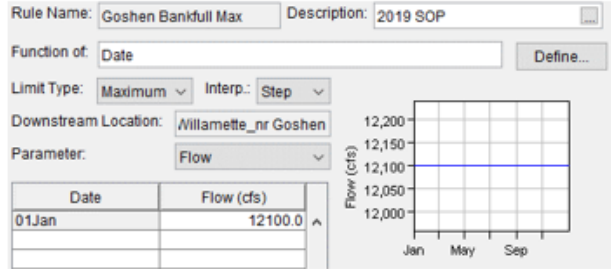

Harrisburg Bankfull Max

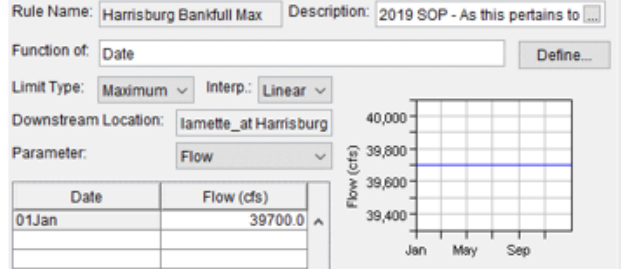

Jasper Bankfull Max

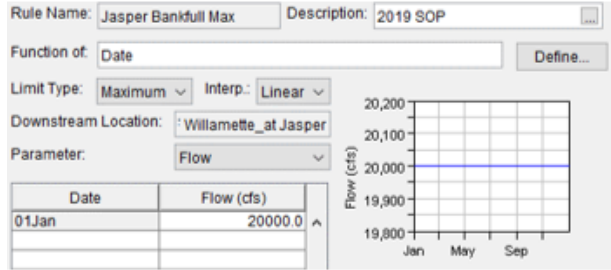

Jefferson Bankfull Max

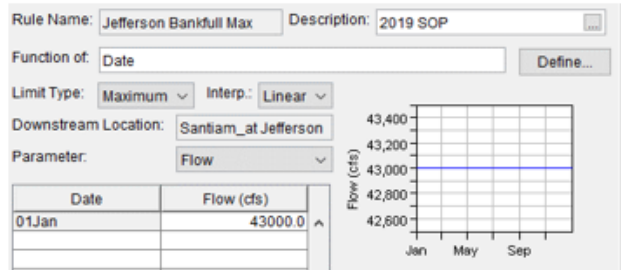

Mehama Bankfull Max

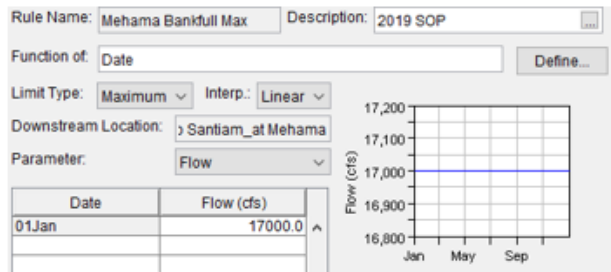

Salem Bankfull Max

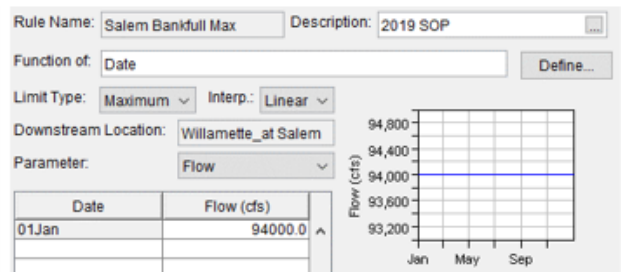

Waterloo Bankfull Max

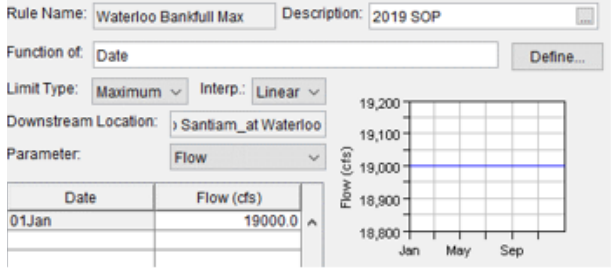

Harrisburg Regulation Goal Max

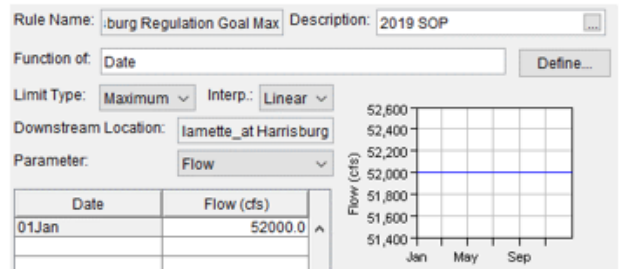

Vida Regulation Goal Max

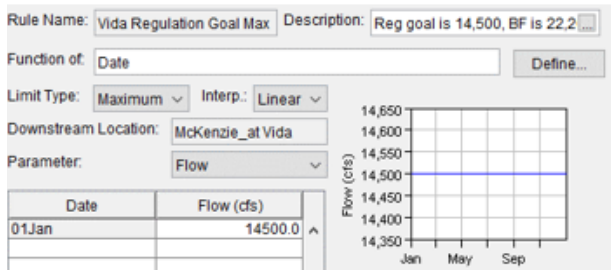

Harrisburg Flood Max

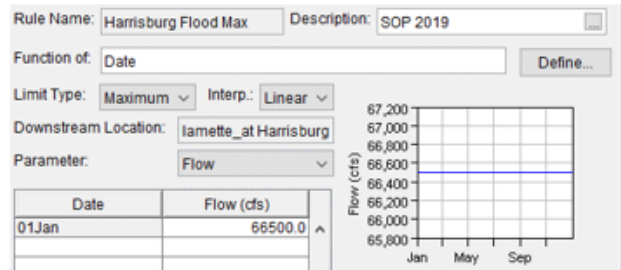

Figure 3-7. HEC-ResSim Screen Shots of Downstream Maximum Rules.

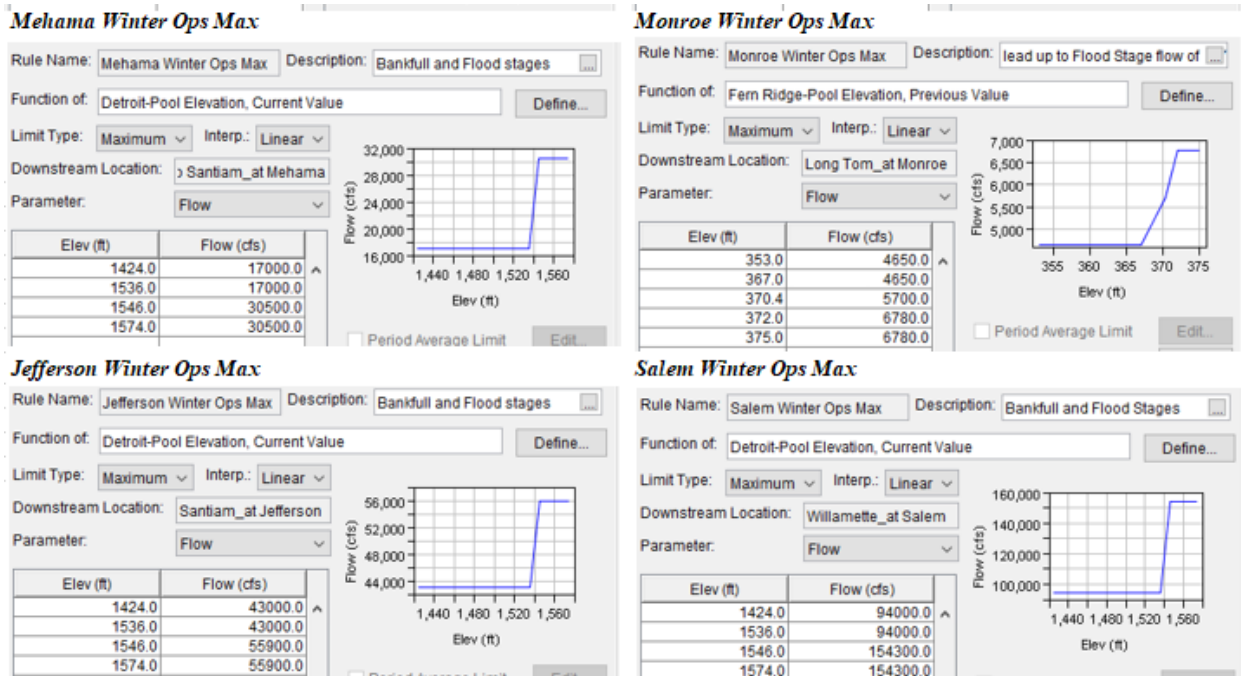

Figure 3-8. HEC-ResSim Screen Shots of Downstream Maximum Rules, Continued.

3.4.7 Downstream Control Points, Minimum Flow Rules

Two control points on the Willamette River mainstem, Albany and Salem, are operated to minimum flows. Multiple dams and reservoirs are used to supplement the local flows to meet the target minimum flows, as shown in Table 3-12.

The Salem and Albany minimum flows were set by the Willamette River Basin Flood Control Project Biological Opinion (NMFS 2008). These minimum flow targets are set by water year type (Abundant, Adequate, Insufficient, or Deficit) and by time of year. The targets are the same for Abundant and Adequate water years, and they are specific for each time period in the year. Water years defined as Insufficient have a minimum Salem flow that varies between that of Abundant/Adequate and Deficit on a sliding scale based on interpolation between the calculated storage volume and the storage values associated with Adequate and Deficit water years. The Albany minimum flows for Insufficient water years are specified rather than interpolated. These minimum flows were shown previously in Table 3-3.

Both minimum flow rules use a two-way table, with time periods and a Water Year Type variable that is input as an external time series. The external variable is the computed water in storage, in kaf, described in Table 3-5. The water year type is defined in a separate dss file. Within the .dss file, the Part B of the water year type variable is called "TOTAL STORAGE", which corresponds to the storage volumes in Table 3-3. The downstream Salem minimum rule is called "Salem BiOp Min by WY" and the downstream Albany minimum rule is "Albany BiOp Min by WY" Screen shots of these two rules are shown in Figure 3-9 and Figure 3-10, respectively.

*Willamette Valley System Operations and Maintenance
Environmental Impact Statement*

Table 3-12. Project Operation for Control Point Minimum Flows.

Control Point	Hills Creek	Lookout Point	Fall Creek	Cottage Grove	Dorena	Cougar	Blue River	Fern Ridge	Green Peter	Foster	Detroit
Salem	√	√	√	√	√	√	√	x	x	x	x
Albany	√	√	√	√	√	√	√	x			

√ Project storage is used by HEC-ResSim to meet minimum flow targets at downstream control point.

x Project does not use a specific HEC-ResSim rule to supplement flow at the downstream control point, but minimum project releases supplement flows at these control points.

Rule Name: Salem BiOp Min by WY Description:

Function of: Water Year Type, Current Value

Limit Type: Minimum Interp.: Step

Dgwnstream Location: Willamette_at Salem

Parameter: Flow

Water Year Type	Flow (cfs)											
	01Jan	01Apr	16Apr	01May	01Jun	16Jun	01Jul	01Aug	16Aug	01Sep	01Oct	01Nov
0.0	0.0	15000.0	15000.0	15000.0	11000.0	5500.0	5000.0	5000.0	5000.0	5000.0	5000.0	0.0
0.9	0.0	15000.0	15000.0	15000.0	11000.0	5500.0	5000.0	5000.0	5000.0	5000.0	5000.0	0.0
1.2	0.0	17800.0	17800.0	15000.0	13000.0	8700.0	6000.0	6000.0	6500.0	7000.0	7000.0	0.0
1.48	0.0	17800.0	17800.0	15000.0	13000.0	8700.0	6000.0	6000.0	6500.0	7000.0	7000.0	0.0
2.0	0.0	17800.0	17800.0	15000.0	13000.0	8700.0	6000.0	6000.0	6500.0	7000.0	7000.0	0.0

Figure 3-9. HEC-ResSim Screen Shot of Minimum Flow—at Salem by Water Year Type Rule.

*Willamette Valley System Operations and Maintenance
Environmental Impact Statement*

Rule Name: Albany BiOp Min by WY Description:

Function of: Water Year Type, Current Value

Limit Type: Minimum Interp.: Step

Downstream Location: Willamette_at Albany

Parameter: Flow

Water Year Type	Flow (cfs)											
	01Jan	01Apr	16Apr	01May	01Jun	16Jun	01Jul	01Aug	16Aug	01Sep	01Oct	01Nov
0.0	0.0	0.0	0.0	0.0	4000.0	4000.0	4000.0	4000.0	4000.0	4000.0	4000.0	0.0
0.9	0.0	0.0	0.0	0.0	4000.0	4000.0	4000.0	4000.0	4000.0	4000.0	4000.0	0.0
1.2	0.0	0.0	0.0	0.0	4500.0	4500.0	4500.0	4500.0	4500.0	4500.0	4500.0	0.0
1.48	0.0	0.0	0.0	0.0	4500.0	4500.0	4500.0	5000.0	5000.0	5000.0	5000.0	0.0
2.0	0.0	0.0	0.0	0.0	4500.0	4500.0	4500.0	5000.0	5000.0	5000.0	5000.0	0.0

Figure 3-10. HEC-ResSim Screen Shot of Minimum Flow—at Albany by Water Year Type Rule.

3.4.8 Rate of Flow Changes, Maximum and Minimum Flows

Each dam and reservoir has ramping rate rules for increasing and decreasing flows. The WCM for each dam and reservoir gives maximum rate of change (ramping rate) values for both filling and drafting, but the Willamette River Basin Flood Control Project Biological Opinion (NMFS 2008) adjusted some of the rates to make for slower changes to flows.

All ramping rate rules at all projects will be the same in WVS EIS action alternatives as they are in the NAA. See each dam and reservoir-specific section for the ramping rate applied at each dam.

There are also maximum and minimum flow rules at each dam and reservoir. As with the ramping rates, the WCMs specify max and min outflows at each dam and reservoir, but the Willamette River Basin Flood Control Project Biological Opinion (NMFS 2008) changed some of the flows. The maximum outflows at every dam and reservoir will be at least as restrictive as the Biological Opinion max in the NAA in all WVS EIS alternatives. Minimum project outflows will be varied in WVS EIS alternatives to evaluate effects. The WVS EIS NAA assumes projected 2050 withdrawals and returns and has minimum flow rules adjusted above the Biological Opinion minimum flows to accommodate these withdrawals. See each dam and reservoir-specific section for the max and min flows applied at each dam in the NAA.

3.4.9 Minimum Project Outflows

Minimum project outflows are accounted for in minimum flow rules. Physical minimum flows defined for specific outlets are used at dams and reservoirs when required.

3.4.10 E-Flows

The Sustainable Rivers Program (SRP) began in 2002 as a partnership between The Nature Conservancy (TNC) and the Corps with the objective of developing, implementing, and refining a framework for beneficial flows downstream of dams. SRP efforts in the Willamette River Basin focus on modifying dam releases within existing operational constraints to improve the overall downstream ecosystem health and resiliency by enhancing channel habitat, modifying channel features, and scouring and flushing of channels. The releases that provide these benefits are termed environmental flows (E-flows).

The E-flows are an opportunity-driven operation that do not use the conservation storage of a reservoir during the summer months, nor are they predictable in timing. Therefore E-flow operations are not modeled in the NAA simulation for the WVS EIS.

3.4.11 IRRM

Interim Risk Reduction Measures (IRRM) are measures that are taken to mitigate temporary risks to dam safety until a permanent solution can be implemented. IRRMs currently implemented in the Willamette River Basin include pool restrictions at Lookout Point, Hills Creek, and Detroit Reservoirs. These pool restrictions are not modeled as part of the NAA because they are temporary.

3.5 Dam and Reservoir-specific Modeled Operations

The following subsections detail the specific operations used in the NAA simulation at individual reservoirs. Big Cliff and Dexter Reservoirs are re-regulating reservoirs passing inflow from upstream reservoirs and do not have operations specified for them.

3.5.1 Blue River Dam and Reservoir Modeled Operations

3.5.1.1 Blue River Dam and Reservoir Operational Summary

A summary of reservoir zones, operations defined for each zone, and each zone's role in reservoir regulation is identified in Figure 3-11. Operations only apply to the zone where they are located. The higher the location of an operation in a zone the higher the priority of that operation.

*Willamette Valley System Operations and Maintenance
Environmental Impact Statement*

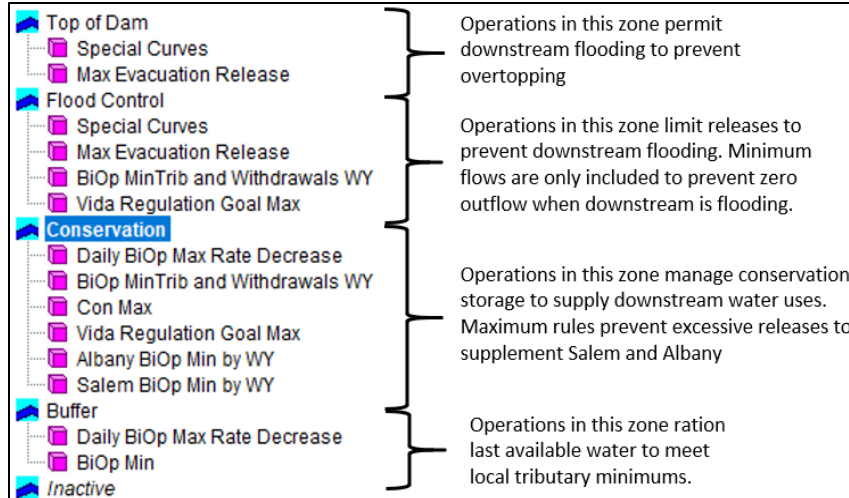

Figure 3-11. Blue River Dam and Reservoir Operational Summary.

3.5.1.2 Blue River Dam and Reservoir HEC-ResSim Water Control Diagram

A water control diagram including all zones in HEC-ResSim is provided in Figure 3-12. A table detailing seasonal zone elevations is provided in Table 3-13. All zones are defined in the dam and reservoir’s water control manual except for the buffer zone. The buffer zone is for modeling purposes intended to estimate likely conservation actions taken by regulators in extremely low storage situations when local tributary flows would be prioritized above withdrawals and mainstem flow targets.

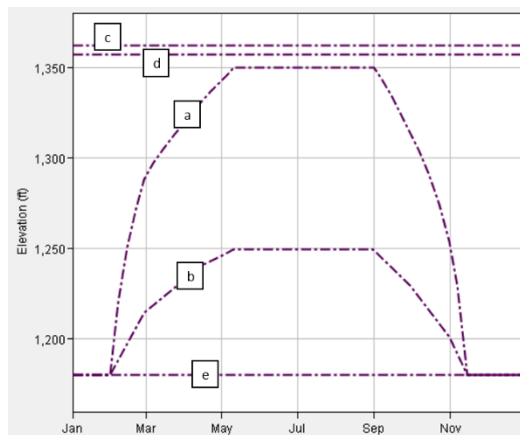

Figure 3-12. Blue River Dam and Reservoir HEC-ResSim Water Control Diagram.

Table 3-13. Blue River Reservoir Zone Elevations.

Conservation Zone (a)	Elevation, feet
1-Jan	1,180.1
31-Jan	1,180.1
7-Feb	1,220.3
14-Feb	1,250.5

*Willamette Valley System Operations and Maintenance
Environmental Impact Statement*

Conservation Zone (a)	Elevation, feet
21-Feb	1,272.0
28-Feb	1,288.4
7-Mar	1,296.9
15-Mar	1,304.7
23-Mar	1,312.1
31-Mar	1,319.0
7-Apr	1,324.8
15-Apr	1,331.1
22-Apr	1,336.5
30-Apr	1,342.3
7-May	1,347.2
11-May	1,350.0
1-Sep	1,350.0
7-Sep	1,343.2
15-Sep	1,333.7
22-Sep	1,324.9
30-Sep	1,313.9
7-Oct	1,303.6
15-Oct	1,290.3
23-Oct	1,274.5
31-Oct	1,253.9
7-Nov	1,229.4
15-Nov	1,180.1
22-Nov	1,180.1
Buffer Zone (b)	Elevation, feet
1-Jan	1,180.0
31-Jan	1,180.0
28-Feb	1,214.8
31-Mar	1,232.6
1-Apr	1,233.2
15-Apr	1,240.6
30-Apr	1,245.6
11-May	1,249.3
31-May	1,249.3
1-Jun	1,249.3
30-Jun	1,249.3
1-Jul	1,249.3
1-Aug	1,249.3
31-Aug	1,249.3
30-Sep	1,229.4
31-Oct	1,201.4

*Willamette Valley System Operations and Maintenance
Environmental Impact Statement*

Conservation Zone (a)	Elevation, feet
1-Nov	1,200.4
15-Nov	1,180.0
31-Dec	1,180.0
Top of Dam Zone (c)	Elevation, feet
All Year	1,362
Flood Control Zone (d)	Elevation, feet
All Year	1,357
Inactive Zone (e)	Elevation, feet
All Year	1,180

3.5.1.3 Blue River Dam and Reservoir Detailed Operational Descriptions

A description of each operation is provided below followed by detailed screenshots of each operation in Figure 3-13 and Figure 3-14:

- *Special Curves Normal* - Maximum outflow as a function of elevation and inflow designed to prevent the reservoir from overtopping.
- *Max Evacuation Release* - Designed to mimic typical flood season maximum releases at a given elevation.
- *BiOp MinTrib and Withdrawals by WY* - A composite minimum flow rule satisfying NMFS 2008 BiOp minimum flows and Projected 2050 withdrawals.
- *Vida Regulation Goal Max* - Regulation goal at Vida, 14,500 cfs.
- *Daily BiOp Max Rate of Decreases* - Designed to result in the lesser of 1 foot per day tailwater change or a 50 percent reduction in flow per the NMFS 2008 BiOp.
- *Con Max* - Maximum outflow during the conservation season limiting contribution to minimum flows at Salem and Albany.
- *Albany BiOp Min by WY* – NMFS 2008 BiOp min flow target at Albany.
- *Salem BiOp Min by WY* – NMFS 2008 BiOp min flow target at Salem.
- *BiOp Min* – NMFS 2008 BiOp minimum tributary flows.

*Willamette Valley System Operations and Maintenance
Environmental Impact Statement*

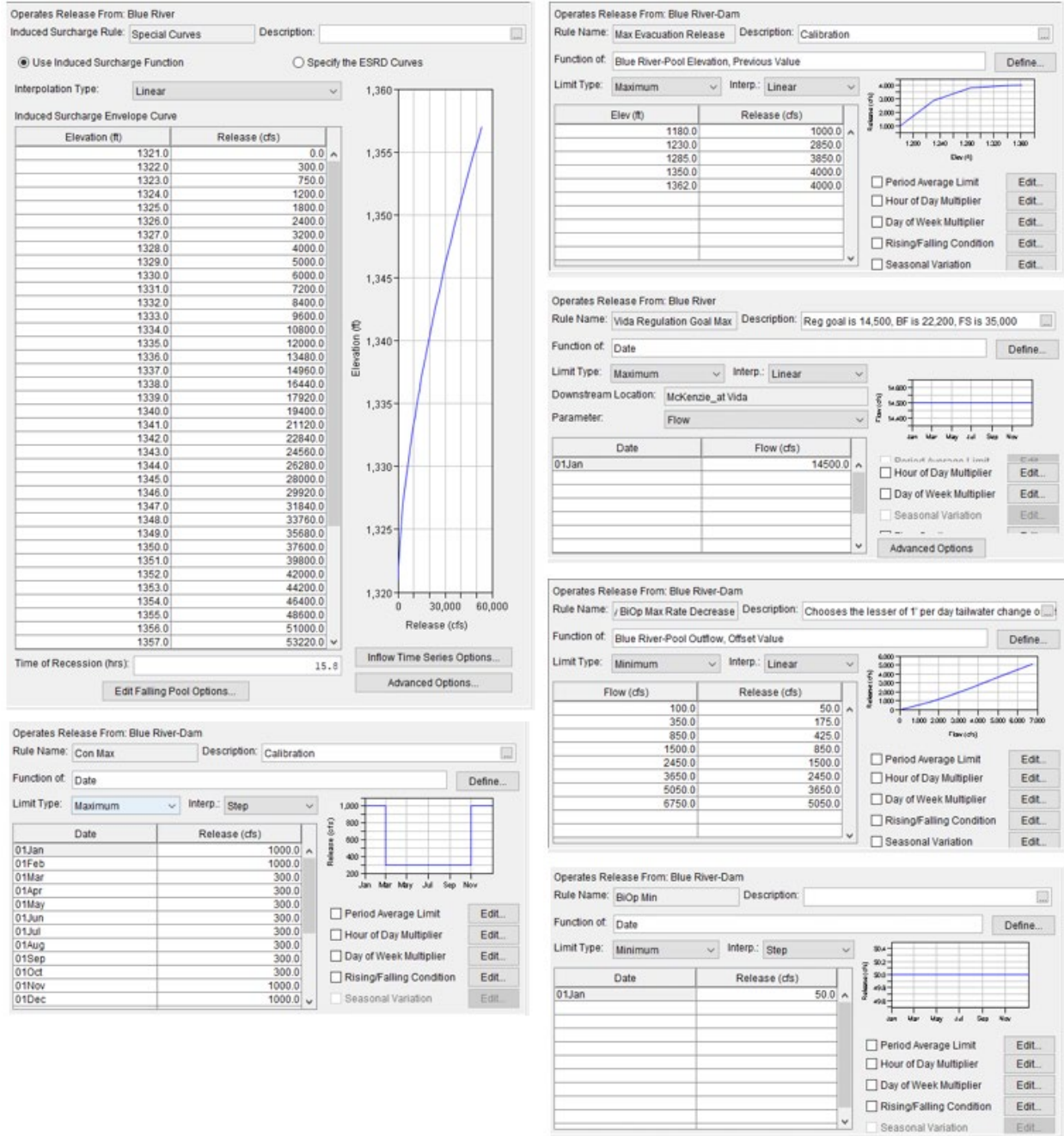

Figure 3-13. Blue River Dam and Reservoir NAA Operation Set Rules.

*Willamette Valley System Operations and Maintenance
Environmental Impact Statement*

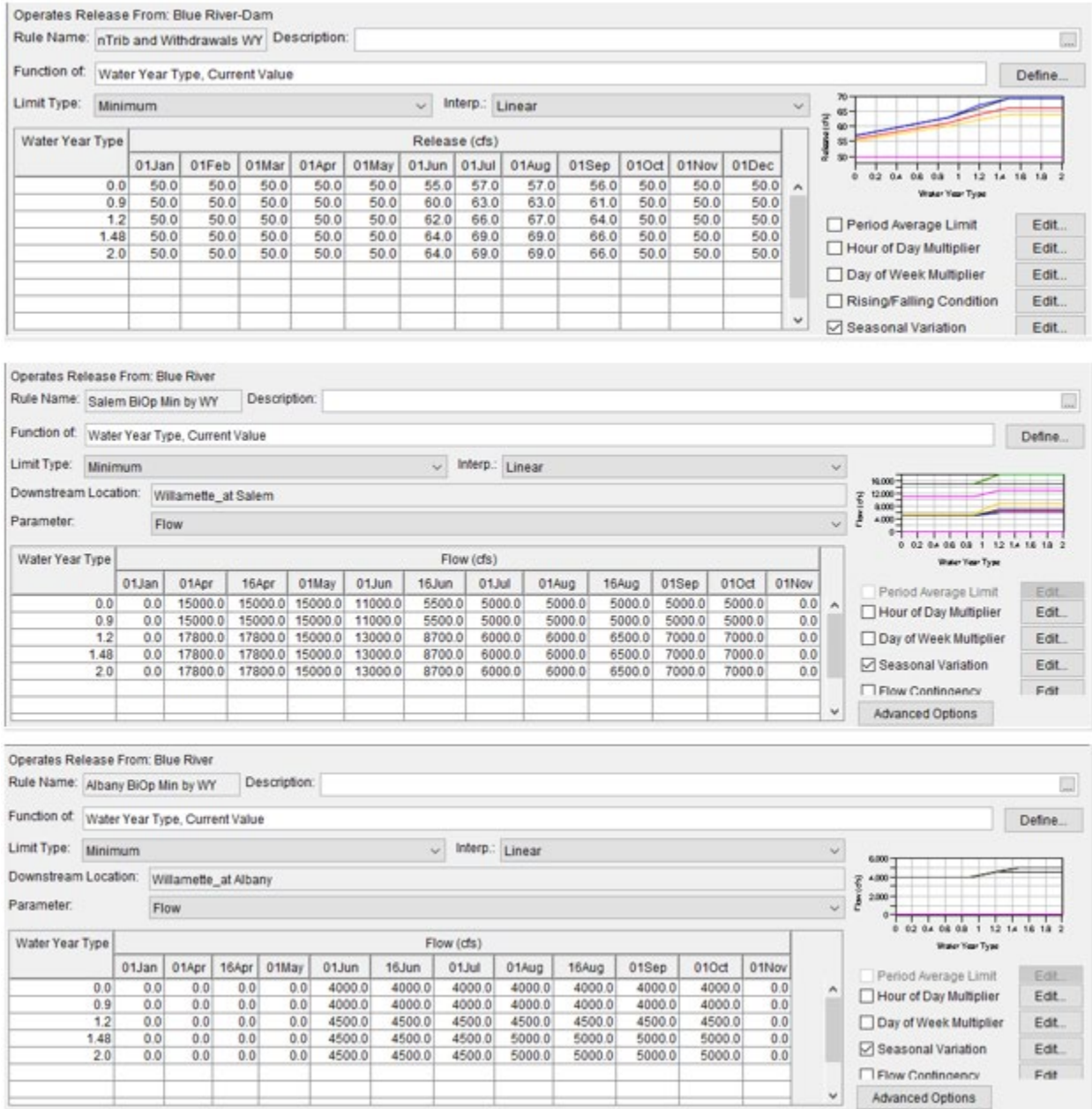

Figure 3-14. Blue River Dam and Reservoir NAA Operation Set Rules, Continued.

3.5.2 Cougar Dam and Reservoir Modeled Operations

3.5.2.1 Cougar Dam and Reservoir Operational Summary

A summary of reservoir zones, operations defined for each zone, and each zone’s role in reservoir regulation is identified in Figure 3-15. Operations only apply to the zone where they are located. The higher the location of an operation in a zone the higher the priority of that operation.

*Willamette Valley System Operations and Maintenance
Environmental Impact Statement*

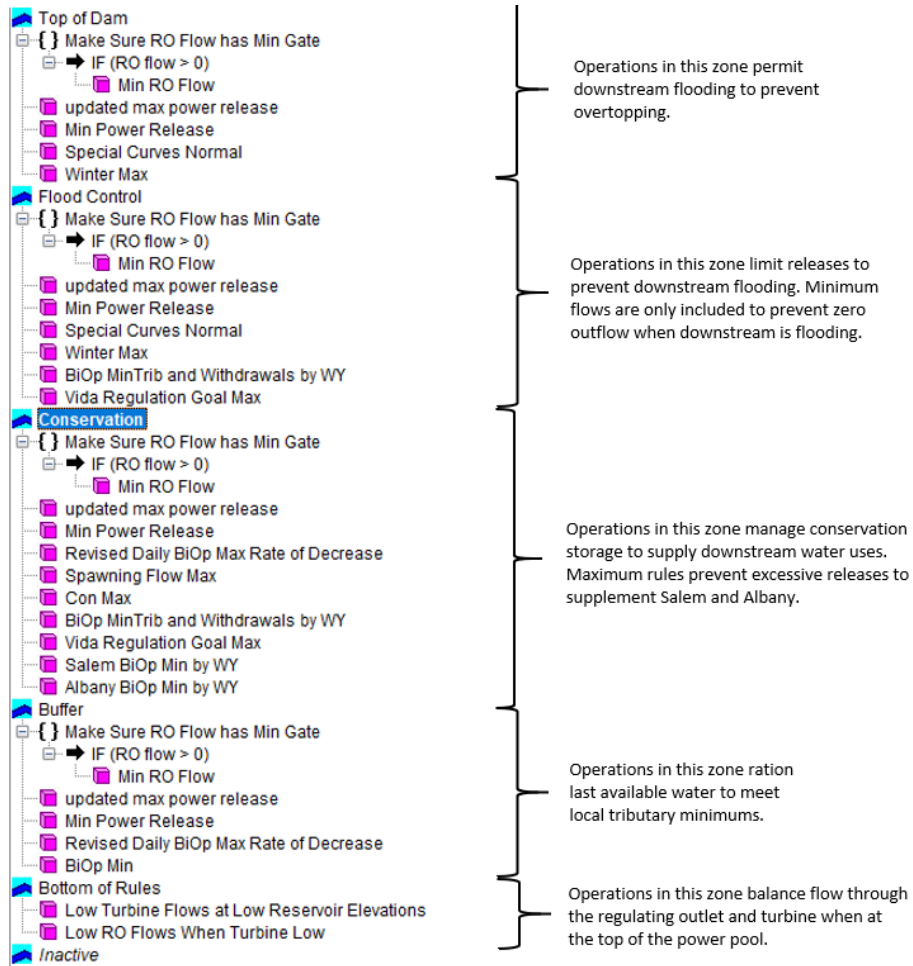
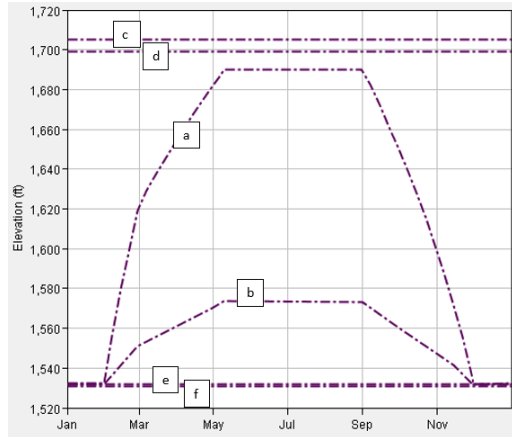

Figure 3-15. Cougar Dam and Reservoir Operational Summary.

3.5.2.2 Cougar Dam and Reservoir HEC-ResSim Water Control Diagram

A water control diagram, including all zones in HEC-ResSim, is provided in Figure 3-16. A table detailing seasonal zone elevations is provided in Table 3-14. All zones are defined in the project’s water control manual except for the buffer zone and bottom of rules. The buffer zone is for modeling purposes intended to estimate likely conservation actions taken by regulators in extremely low storage situations when local tributary flows would be prioritized above withdrawals and mainstem flow targets. The bottom of rules zone balances turbine and regulating outlet flow when at the boundary of the inactive zone, which is also the top of the power pool.

*Willamette Valley System Operations and Maintenance
Environmental Impact Statement*



**Figure 3-16. Cougar Dam and Reservoir HEC-ResSim
Water Control Diagram.**

Table 3-14. Cougar Reservoir Zone Elevations.

Conservation Zone (a)	Elevation, feet
1-Jan	1,532.1
31-Jan	1,532.1
7-Feb	1,555.9
14-Feb	1,579.5
21-Feb	1,600.2
28-Feb	1,618.9
7-Mar	1,629.1
15-Mar	1,637.7
23-Mar	1,645.9
31-Mar	1,653.8
7-Apr	1,660.5
15-Apr	1,667.9
22-Apr	1,674.3
30-Apr	1,681.4
7-May	1,687.4
15-May	1,690.0
31-Aug	1,690.0
7-Sep	1,682.4
15-Sep	1,671.9
22-Sep	1,662.4
30-Sep	1,651.1
7-Oct	1,640.8
15-Oct	1,628.3
23-Oct	1,615.1
31-Oct	1,600.1
7-Nov	1,587.7
15-Nov	1,571.1

*Willamette Valley System Operations and Maintenance
Environmental Impact Statement*

Conservation Zone (a)	Elevation, feet
22-Nov	1,555.3
30-Nov	1,534.7
1-Dec	1,532.0
Buffer Zone (b)	Elevation, feet
1-Jan	1,532.0
31-Jan	1,532.0
28-Feb	1,551.1
30-Apr	1,570.3
10-May	1,573.6
1-Sep	1,573.1
30-Sep	1,560.8
15-Nov	1,541.3
30-Nov	1,532.0
Top of Dam Zone (c)	Elevation, feet
All Year	1,705
Flood Control Zone (d)	Elevation, feet
All Year	1,699
Bottom of Rules Zone (e)	Elevation, feet
All Year	1,532
Inactive Zone (f)	Elevation, feet
All Year	1,531

3.5.2.3 Cougar Dam and Reservoir Detailed Operational Descriptions

A description of each operation at Cougar Dam and Reservoir is provided below followed by detailed screenshots of each operation in Figure 3-17, Figure 3-18, and Figure 3-19.

- *Minimum Regulating Outlet Flow* - minimum flow from regulating outlet based on minimum gate opening.
- *Updated Maximum Power Release* - Maximum powerhouse release as a function of elevation.
- *Minimum Power Release* - minimum flow through powerhouse with reservoir elevation.
- *Special Curves Normal* - induced surcharge function allowing for high releases to prevent overtopping.
- *Winter Maximum* - Maximum release as a function of pool elevation. Designed to mimic flood season maximum releases.
- *BiOp MinTrib and Withdrawals by WY* - Includes minimum flows to satisfy the NMFS 2008 BiOp and 2050 projected consumptive withdrawals.
- *Vida Regulation Goal Maximum* - Regulation goal at Vida is 14,500 cfs.

*Willamette Valley System Operations and Maintenance
Environmental Impact Statement*

- *Spawning Flow Maximum* – NMFS 2008 BiOp maximum flow for spawning of 580 cfs.
- *Con Maximum* - Normal maximum outflow during the conservation season as a function of date. Rule limits drafting to meet minimum flows at Salem and Albany.
- *Revised Daily BiOp Maximum Rate of Decrease* - Defines the next day's minimum outflow as a function of current outflow. Designed to result in the lesser of 1 foot per day tailwater change or a 50 percent reduction in flow per the NMFS 2008 BiOp.
- *Albany BiOp Minimum by WY* – NMFS 2008 BiOp minimum flow target at Albany.
- *Salem BiOp Minimum by WY* – NMFS 2008 BiOp minimum flow target at Salem.
- *BiOp Minimum* – NMFS 2008 BiOp minimum tributary flows.
- *Low Turbine Flows at Low Reservoir Elevations* - specified low level releases through the turbine when flows out of project are less than the 400 cfs minimum. This low flow is either speed no load (100 cfs) or the approx. 300 cfs minimum. Is only used in the Bottom of Rules zone.
- *Low Regulating Outlet Flows When Turbine Low* - Balances regulating outlet and turbine flows when reservoir elevations are very low.

*Willamette Valley System Operations and Maintenance
Environmental Impact Statement*

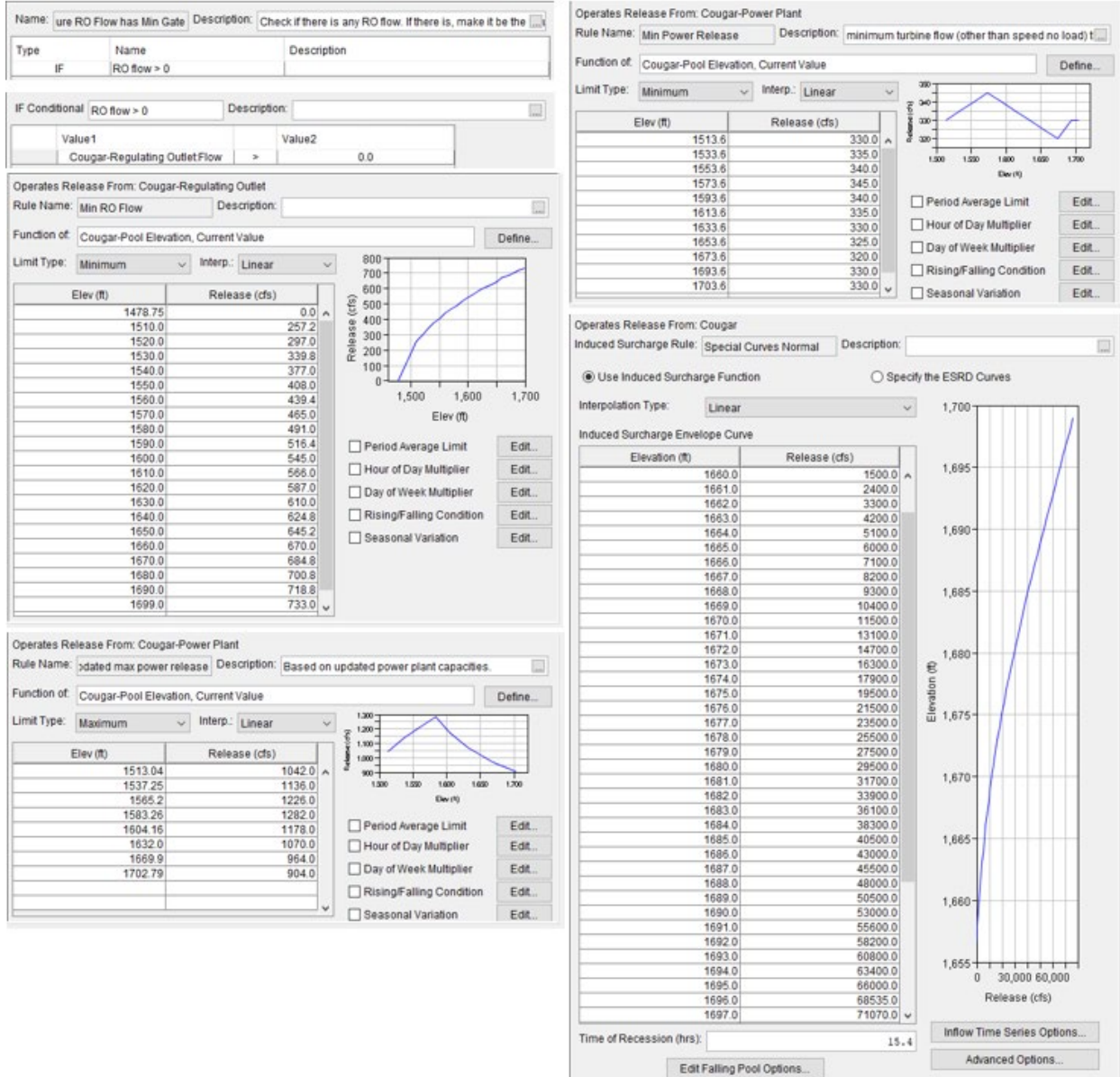

Figure 3-17. Cougar Dam and Reservoir NAA Operation Set Rules.

*Willamette Valley System Operations and Maintenance
Environmental Impact Statement*

Operates Release From: Cougar
 Rule Name: Winter Max Description: Calibration
 Function of: Cougar-Pool Elevation, Previous Value
 Limit Type: Maximum Interp.: Linear

Elev (ft)	Release (cfs)
1532.0	1200.0
1540.0	1200.0
1590.0	5000.0
1601.6	5270.0
1612.6	5520.0
1647.3	6320.0
1649.3	6370.0
1650.4	6390.0
1655.0	6500.0
1678.5	6500.0
1680.5	6500.0
1688.0	6500.0
1690.0	6500.0
1691.0	6500.0
1699.0	6500.0

Operates Release From: Cougar
 Rule Name: Con Max Description: Calibration
 Function of: Date
 Limit Type: Maximum Interp.: Step

Date	Release (cfs)
01Jan	900.0
01Apr	900.0
01Aug	1000.0
01Sep	580.0
16Oct	900.0

Operates Release From: Cougar
 Rule Name: Vida Regulation Goal Max Description: Reg goal is 14,500, BF is 22,200, FS is 35,000
 Function of: Date
 Limit Type: Maximum Interp.: Linear
 Downstream Location: McKenzie_at Vida
 Parameter: Flow

Date	Flow (cfs)
01Jan	14500.0

Operates Release From: Cougar
 Rule Name: iOp Max Rate of Decrease Description: Chooses the lesser of 1' per day tailwater change
 Function of: Cougar-Pool Outflow, Offset Value
 Limit Type: Minimum Interp.: Linear

Flow (cfs)	Release (cfs)
100.0	50.0
800.0	400.0
1800.0	900.0
3400.0	1800.0
5600.0	3400.0
8200.0	5600.0
11300.0	8200.0
14900.0	11300.0

Operates Release From: Cougar
 Rule Name: Spawning Flow Max Description: WFOP Spawning season requirement of 3000cfs
 Function of: Date
 Limit Type: Maximum Interp.: Step

Date	Release (cfs)
01Jan	999999.0
01Sep	580.0
16Oct	999999.0

Operates Release From: Cougar
 Rule Name: BiOp Min Description: BiOp calls for 300 cfs Jul-May and 400 cfs in June
 Function of: Date
 Limit Type: Minimum Interp.: Step

Date	Release (cfs)
01Jan	300.0
01Jun	400.0
01Jul	300.0

Operates Release From: Cougar
 Rule Name: Low Reservoir Elevations Description: Use this rule only near the minimum conservation
 Function of: Cougar-Pool Net Inflow, Current Value
 Limit Type: Specified Interp.: Linear

Flow (cfs)	Release (cfs)
0.0	100.0
100.0	100.0
333.9	100.0
334.0	334.0
400.0	400.0
3000.0	400.0

Operates Release From: Cougar
 Rule Name: Flows When Turbine Low Description: Balances total flow out (power plus RO) with the turbine
 Function of: Cougar-Pool Net Inflow, Current Value
 Limit Type: Specified Interp.: Linear

Flow (cfs)	Release (cfs)
0.0	100.0
100.0	100.0
400.0	400.0
5000.0	400.0

Figure 3-18. Cougar Dam and Reservoir NAA Operation Set Rules, Continued.

*Willamette Valley System Operations and Maintenance
Environmental Impact Statement*

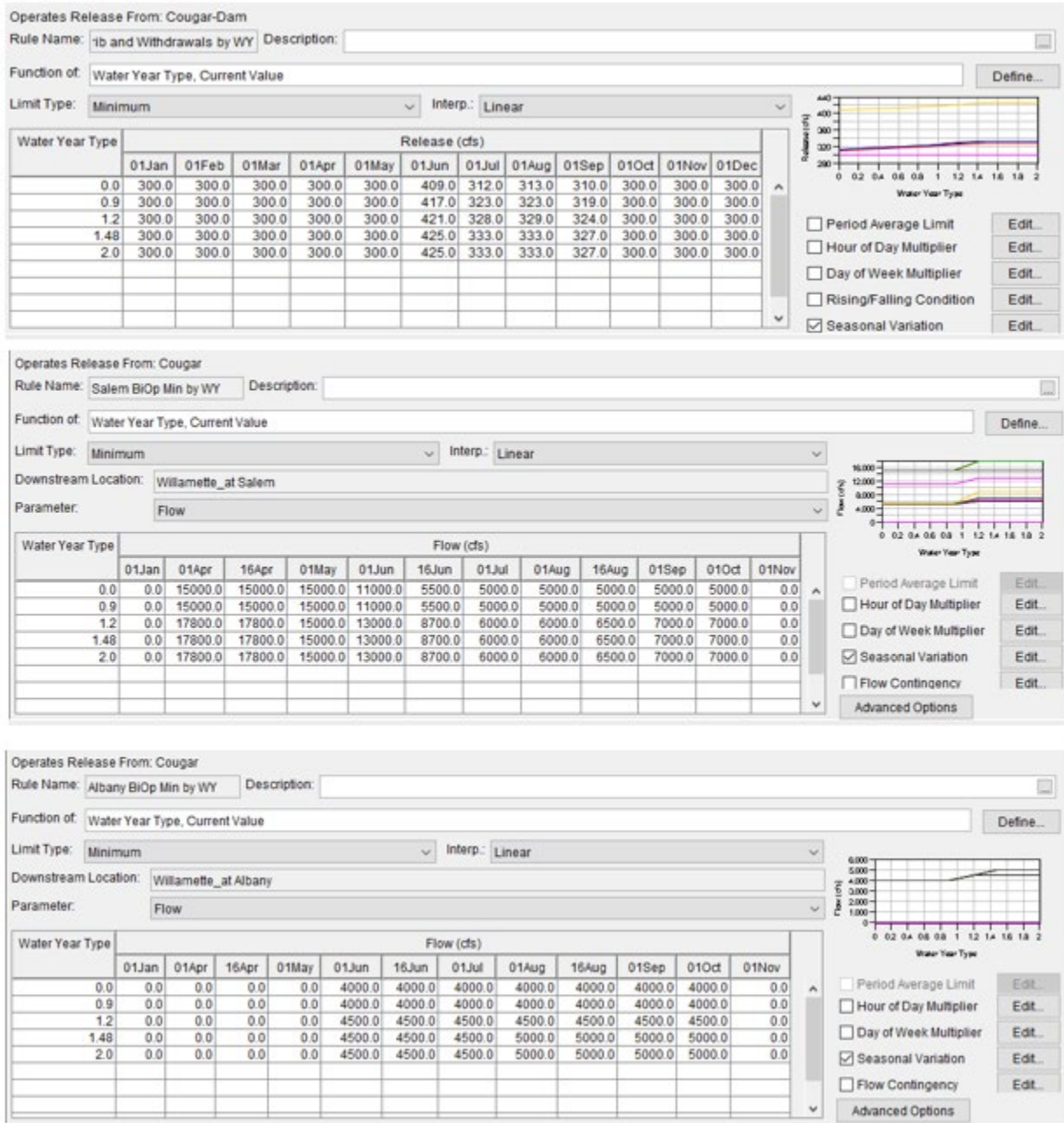

Figure 3-19. Cougar Dam and Reservoir NAA Operation Set Rules, Continued.

3.5.3 Dorena Dam and Reservoir Modeled Operations

3.5.3.1 Dorena Dam and Reservoir Operational Summary

A summary of reservoir zones, operations defined for each zone, and each zone’s role in reservoir regulation is identified in Figure 3-20. Operations only apply to the zone where they are located. The higher the location of an operation in a zone the higher the priority of that operation.

*Willamette Valley System Operations and Maintenance
Environmental Impact Statement*

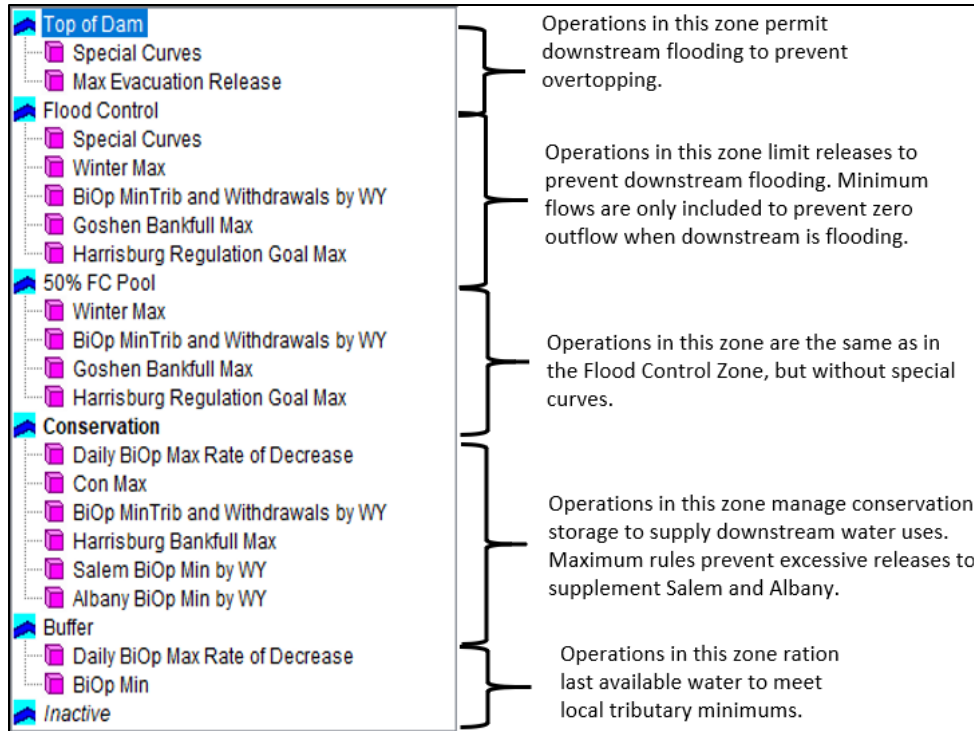

Figure 3-20. Dorena Dam and Reservoir Operational Summary.

3.5.3.2 Dorena Dam and Reservoir HEC-ResSim Water Control Diagram

A water control diagram, including all zones in HEC-ResSim, is provided in Figure 3-21. A table detailing seasonal zone elevations is provided in Table 3-15. All zones are defined in the project’s water control manual except for the buffer zone and 50 percent FC Pool. The 50 percent FC Pool allows for different flood control rules when at lower elevations in the flood zone. The buffer zone is for modeling purposes intended to estimate likely conservation actions taken by regulators in extremely low storage situations when local tributary flows would be prioritized above withdrawals and mainstem flow targets.

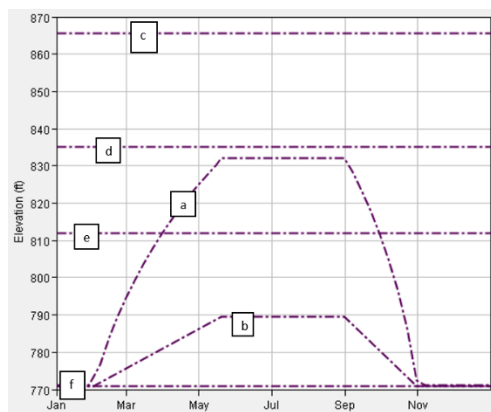

Figure 3-21. Dorena Dam and Reservoir HEC-ResSim Water Control Diagram.

*Willamette Valley System Operations and Maintenance
Environmental Impact Statement*

Table 3-15. Dorena Reservoir Zone Elevations.

Conservation Zone (a)	Elevation, feet
1-Jan	771.1
28-Jan	771.1
7-Feb	776.8
14-Feb	783.4
21-Feb	789.2
28-Feb	794.3
7-Mar	798.9
15-Mar	803.6
23-Mar	808.0
31-Mar	812.0
7-Apr	815.3
15-Apr	818.8
22-Apr	821.7
30-Apr	824.8
7-May	827.4
15-May	830.2
20-May	832.0
31-Aug	832.0
7-Sep	828.4
15-Sep	823.1
22-Sep	818.0
30-Sep	811.5
7-Oct	805.0
15-Oct	796.6
23-Oct	786.2
31-Oct	772.5
7-Nov	771.1
Buffer Zone (b)	Elevation, feet
1-Jan	771.0
1-Feb	771.0
20-May	789.5
31-Aug	789.5
31-Oct	771.0
Top of Dam Zone (c)	Elevation, feet
All Year	865.5
Flood Control Zone (d)	Elevation, feet
All Year	835
50% FC Pool Zone (e)	Elevation, feet
All Year	812

*Willamette Valley System Operations and Maintenance
Environmental Impact Statement*

Conservation Zone (a)	Elevation, feet
Inactive Zone (f)	Elevation, feet
All Year	771

3.5.3.3 Dorena Dam and Reservoir Detailed Operational Descriptions

A description of each operation at Dorena Dam and Reservoir is provided below followed by detailed screenshots of each operation in Figure 3-22 and Figure 3-23.

- *Special Curves Normal* – induced surcharge function, a function of elevation and inflow. Designed for flood events that present risk of dam overtopping.
- *Maximum Evacuation Release* – Maximum release as a function of pool elevation. Designed to mimic flood season maximum releases.
- *BiOp MinTrib and Withdrawals by WY* – Includes minimum flows to satisfy the NMFS 2008 BiOp and 2050 projected consumptive withdrawals.
- *Winter Maximum* - Maximum release as a function of the previous pool elevation. Designed to mimic flood season maximum releases.
- *Goshen Bankfull Max* – Bankfull at Goshen is 12,100 cfs.
- *Harrisburg Regulation Goal Max* – Regulation goal at Harrisburg is 52,000 cfs.
- *Daily BiOp Maximum Rate of Decrease* – Defines the next day’s minimum outflow as a function of current outflow. Designed to result in the lesser of 1 foot per day tailwater change or a 50 percent reduction in flow per the NMFS 2008 BiOp.
- *Con Max* - Normal maximum outflow during the conservation season as a function of date. Rule limits drafting to meet minimum flows at Salem and Albany.
- *Harrisburg Bankfull Max* – Bankfull at Harrisburg is 39,700 cfs.
- *Albany BiOp Minimum by WY* – NMFS 2008 BiOp minimum flow target at Albany.
- *Salem BiOp Minimum by WY* – NMFS 2008 BiOp minimum flow target at Salem.
- *BiOp Minimum* – NMFS 2008 BiOp minimum tributary flows.

*Willamette Valley System Operations and Maintenance
Environmental Impact Statement*

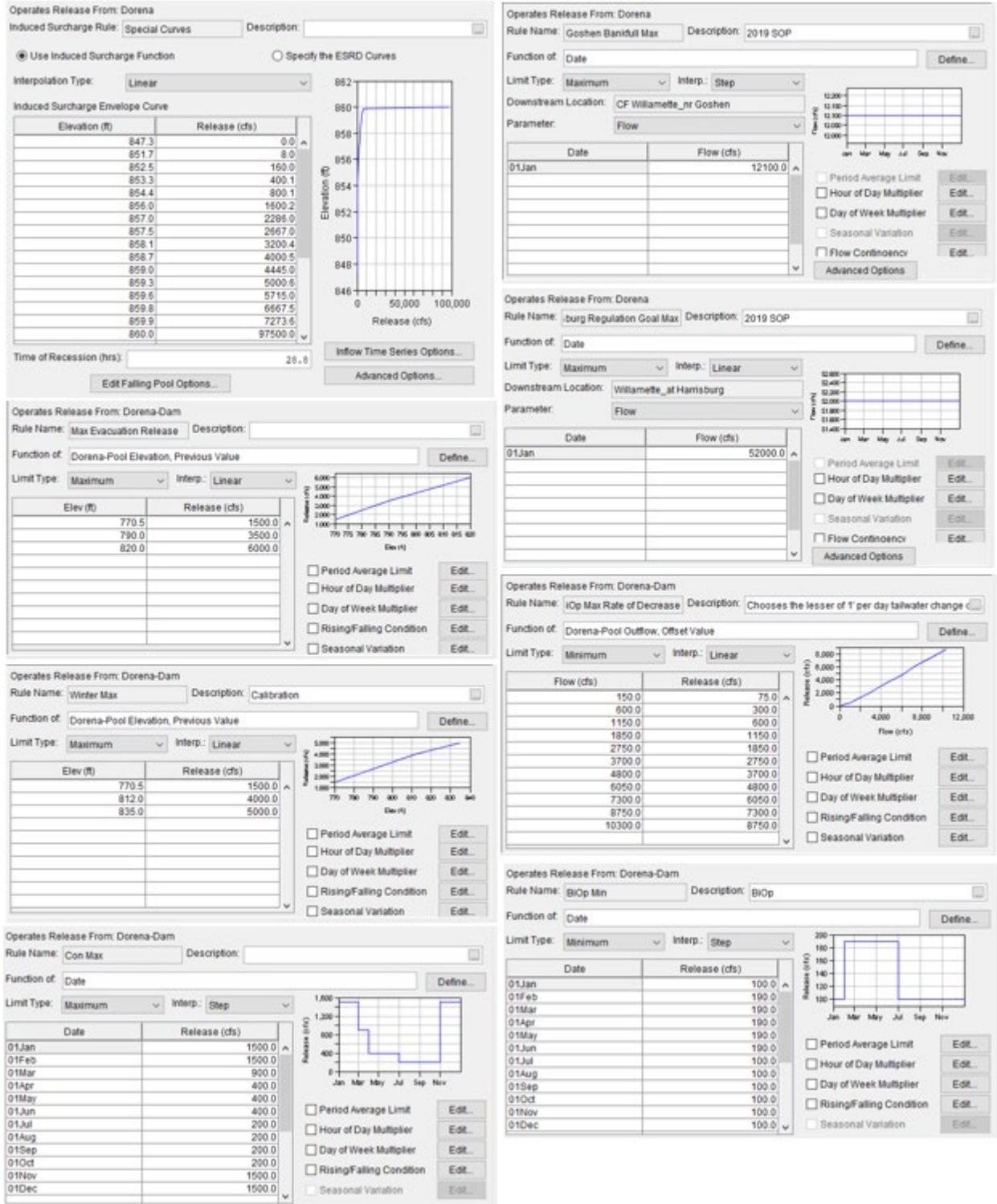

Figure 3-22. Dorena Dam and Reservoir NAA Operation Set Rules.

*Willamette Valley System Operations and Maintenance
Environmental Impact Statement*

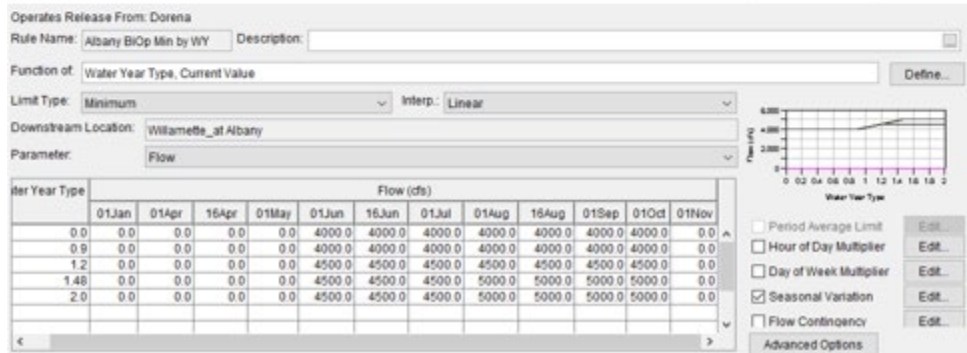
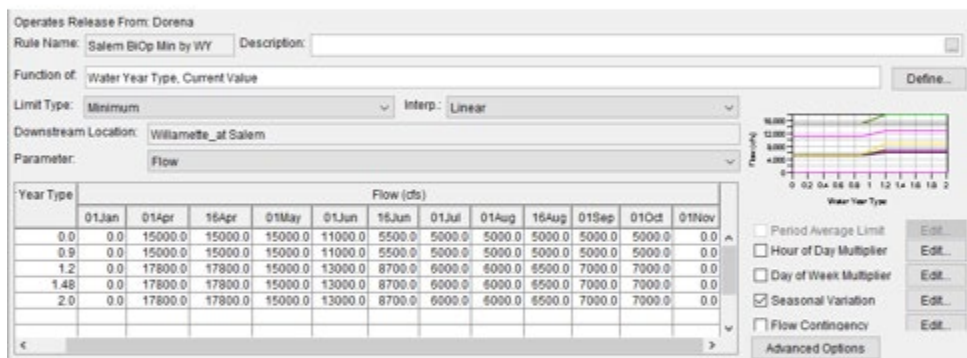
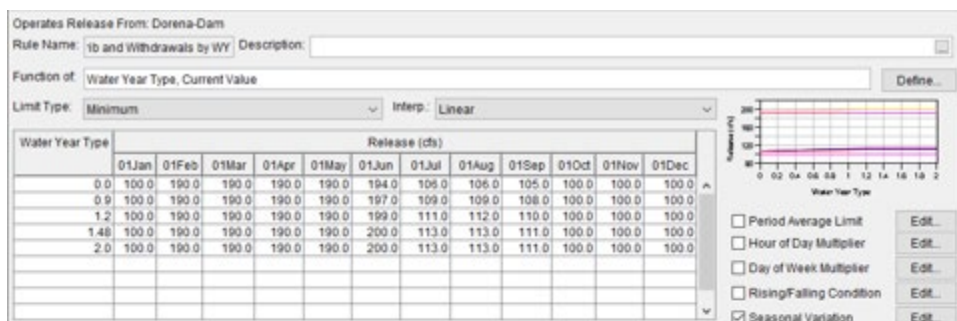

Figure 3-23. Dorena Dam and Reservoir NAA Operation Set Rules, Continued.

3.5.4 Cottage Grove Dam and Reservoir Modeled Operations

3.5.4.1 Cottage Grove Dam and Reservoir Operational Summary

A summary of reservoir zones, operations defined for each zone, and each zone’s role in reservoir regulation is identified in Figure 3-24. Operations only apply to the zone where they are located. The higher the location of an operation in a zone the higher the priority of that operation.

*Willamette Valley System Operations and Maintenance
Environmental Impact Statement*

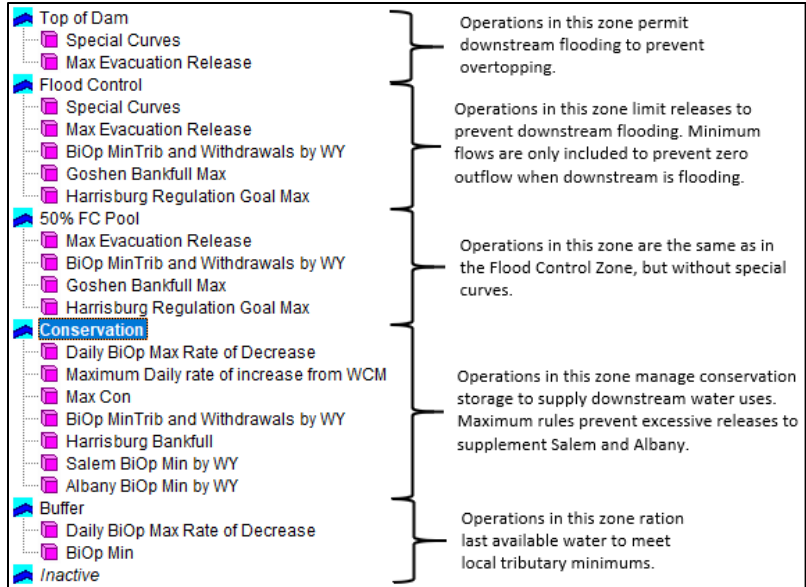

Figure 3-24. Cottage Grove Dam and Reservoir Operational Summary.

3.5.4.2 Cottage Grove Dam and Reservoir HEC-ResSim Water Control Diagram

A water control diagram including all zones in HEC-ResSim is provided in Figure 3-25. A table detailing seasonal zone elevations is provided in Table 3-16. All zones are defined in the project’s water control manual except for the buffer zone and 50 percent FC Pool. The 50 percent FC Pool allows for different flood control rules when at lower elevations in the flood zone. The buffer zone is for modeling purposes intended to estimate likely conservation actions taken by regulators in extremely low storage situations when local tributary flows would be prioritized above withdrawals and mainstem flow targets.

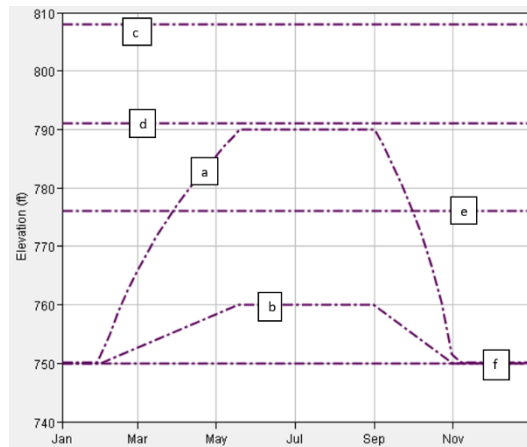

Figure 3-25. Cottage Grove Dam and Reservoir HEC-ResSim Water Control Diagram.

*Willamette Valley System Operations and Maintenance
Environmental Impact Statement*

Table 3-16. Cottage Grove Reservoir Zone Elevations.

Conservation Zone (a)	Elevation, feet
1-Jan	750.1
28-Jan	750.1
7-Feb	754.7
14-Feb	758.9
21-Feb	762.5
28-Feb	765.6
7-Mar	768.5
15-Mar	771.6
23-Mar	774.3
31-Mar	776.9
7-Apr	779.0
15-Apr	781.3
22-Apr	783.2
30-Apr	785.3
7-May	787.1
15-May	789.0
19-May	790.0
1-Sep	790.0
7-Sep	787.5
15-Sep	783.9
22-Sep	780.5
30-Sep	776.3
7-Oct	772.2
15-Oct	766.8
23-Oct	760.4
31-Oct	751.5
7-Nov	750.1
Buffer Zone (b)	Elevation, feet
1-Jan	750.0
31-Jan	750.0
18-May	760.0
31-Aug	760.0
1-Nov	750.0
Top of Dam Zone (c)	Elevation, feet
All Year	808
Flood Control Zone (d)	Elevation, feet
All Year	791
50% FC Pool Zone (e)	Elevation, feet
All Year	776

*Willamette Valley System Operations and Maintenance
Environmental Impact Statement*

Conservation Zone (a)	Elevation, feet
Inactive Zone (f)	Elevation, feet
All Year	750

3.5.4.3 Cottage Grove Dam and Reservoir Detailed Operational Descriptions

A description of each operation at Cottage Grove Dam and Reservoir is provided below followed by detailed screenshots of each operation in Figure 3-26 and Figure 3-27.

- *Special Curves* - Induced surcharge function, a function of elevation and inflow. Designed for flood events that present risk of dam overtopping.
- *Maximum Evacuation Release* - Maximum release as a function of pool elevation. Designed to mimic flood season maximum releases.
- *BiOp MinTrib and Withdrawals by WY* - Includes minimum flows to satisfy the NMFS 2008 BiOp and 2050 projected consumptive withdrawals.
- *Goshen Bankfull Maximum* - Bankfull at Goshen is 12,100 cfs.
- *Harrisburg Regulation Goal Maximum* - Regulation goal at Harrisburg is 52,000 cfs.
- *Daily BiOp Maximum Rate of Decrease* - Defines the next day’s minimum outflow as a function of current outflow. Designed to result in the lesser of 1 foot per day tailwater change or a 50 percent reduction in flow per the NMFS 2008 BiOp.
- *Maximum Daily rate of Increase from WCM* - Maximum release ramping rate from water control manual.
- *Con Max* - Normal maximum outflow during the conservation season as a function of date. Rule limits drafting to meet minimum flows at Salem and Albany.
- *Harrisburg Bankfull Maximum* – Harrisburg bankfull maximum is 39,700 cfs.
- *Albany BiOp Minimum by WY* – NMFS 2008 BiOp minimum flow target at Albany.
- *Salem BiOp Minimum by WY* – NMFS 2008 BiOp minimum flow target at Salem.
- *BiOp Minimum* – NMFS 2008 BiOp minimum tributary flows.

*Willamette Valley System Operations and Maintenance
Environmental Impact Statement*

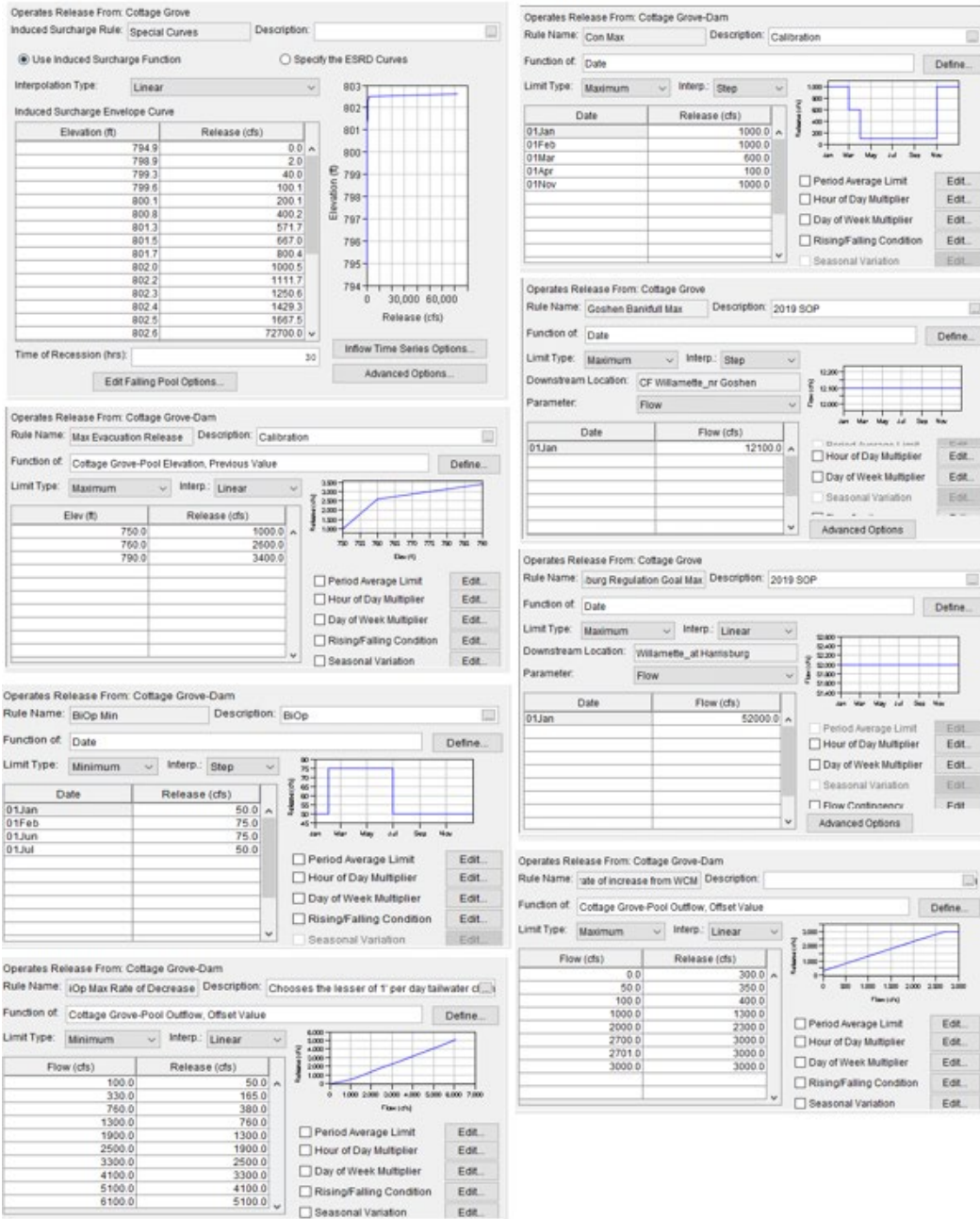

Figure 3-26. Cottage Grove Dam and Reservoir NAA Operation Set Rules.

*Willamette Valley System Operations and Maintenance
Environmental Impact Statement*

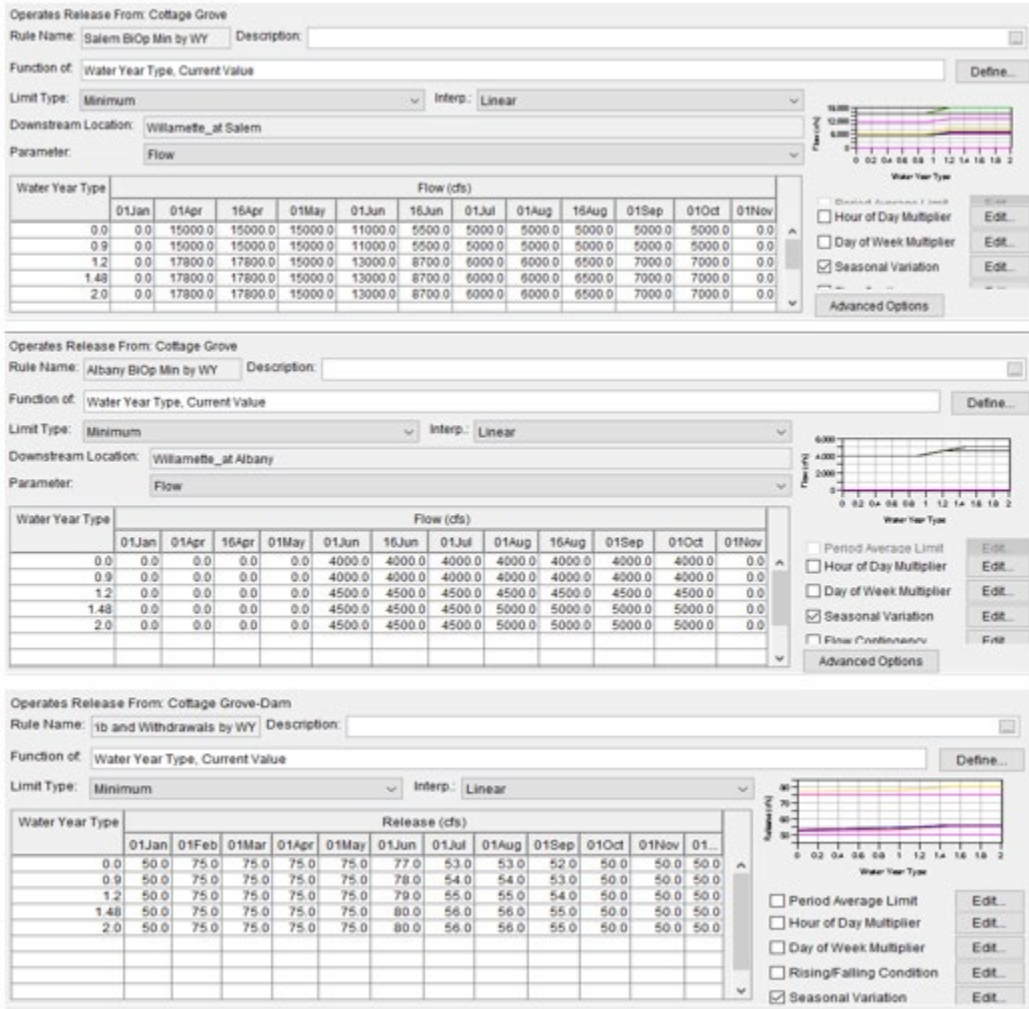

Figure 3-27. Cottage Grove Dam and Reservoir NAA Operation Set Rules, Continued.

3.5.5 Fall Creek Dam and Reservoir Modeled Operations

3.5.5.1 Fall Creek Dam and Reservoir Operational Summary

A summary of reservoir zones, operations defined for each zone, and each zone’s role in reservoir regulation is identified in Figure 3-28. Operations only apply to the zone where they are located. The higher the location of an operation in a zone the higher the priority of that operation.

*Willamette Valley System Operations and Maintenance
Environmental Impact Statement*

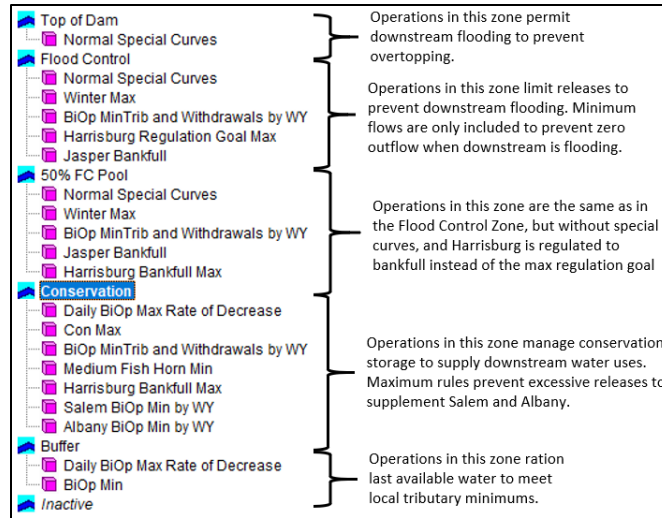

Figure 3-28. Fall Creek Dam and Reservoir Operational Summary.

3.5.5.2 Fall Creek Dam and Reservoir HEC-ResSim Water Control Diagram

A water control diagram, including all zones in HEC-ResSim, is provided in Figure 3-29. A table detailing seasonal zone elevations is provided in Table 3-17. All zones are defined in the project’s water control manual except for the buffer zone and 50 percent FC Pool. The 50 percent FC Pool allows for different flood control rules when at lower elevations in the flood zone. The buffer zone is for modeling purposes intended to estimate likely conservation actions taken by regulators in extremely low storage situations when local tributary flows would be prioritized above withdrawals and mainstem flow targets.

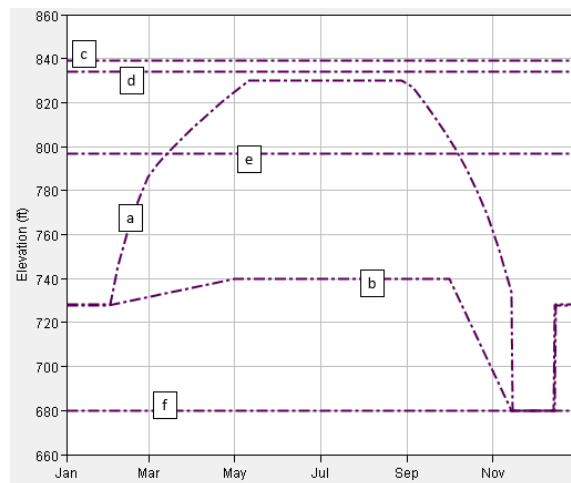

Figure 3-29. Fall Creek Dam and Reservoir HEC-ResSim Water Control Diagram.

*Willamette Valley System Operations and Maintenance
Environmental Impact Statement*

Table 3-17. Fall Creek Reservoir Zone Elevations.

Conservation Zone (a)	Elevation, feet
1-Jan	728.1
28-Jan	728.1
1-Feb	728.1
7-Feb	745.8
14-Feb	761.9
21-Feb	775.0
28-Feb	786.2
7-Mar	792.1
15-Mar	797.8
23-Mar	803.1
31-Mar	808.0
7-Apr	812.1
15-Apr	816.6
22-Apr	820.4
30-Apr	824.5
7-May	828.0
11-May	830.0
22-Aug	830.0
28-Aug	830.0
5-Sep	826.8
12-Sep	821.0
20-Sep	814.0
27-Sep	807.4
5-Oct	799.1
13-Oct	790.0
21-Oct	779.5
28-Oct	768.9
5-Nov	754.5
14-Nov	733.8
15-Nov	680.1
15-Dec	680.1
16-Dec	728.1
Buffer Zone (b)	Elevation, feet
1-Jan	728.00
31-Jan	728.00
1-May	740.00
1-Oct	740.00
14-Nov	680.00
14-Dec	680.00
15-Dec	728.00

*Willamette Valley System Operations and Maintenance
Environmental Impact Statement*

Conservation Zone (a)	Elevation, feet
Top of dam Zone (c)	Elevation, feet
All Year	839
Flood Control Zone (d)	Elevation, feet
All Year	834
50% Flood Control Pool (e)	Elevation, feet
All Year	834
Inactive Zone (f)	Elevation, feet
All Year	680

3.5.5.3 Fall Creek Dam and Reservoir Detailed Operational Descriptions

A description of each operation at Fall Creek Dam and Reservoir is provided below followed by detailed screenshots of each operation in Figure 3-30 and Figure 3-31.

- *Normal Special Curves* - Induced surcharge function, a function of elevation and inflow. Designed for flood events that present risk of dam overtopping.
- *Winter Maximum* - Maximum release as a function of pool elevation. Designed to mimic flood season maximum releases.
- *BiOp MinTrib and Withdrawals by WY* - Includes minimum flows to satisfy the NMFS 2008 BiOp and 2050 projected consumptive withdrawals.
- *Harrisburg Regulation Goal Maximum* - Regulation goal at Harrisburg is 52,000 cfs.
- *Jasper bankfull Maximum* - Jasper bankfull is 20,000 cfs.
- *Harrisburg Bankfull Maximum* - Harrisburg bankfull maximum is 39,700 cfs.
- *Daily BiOp Maximum Rate of Decrease* - Defines the next day’s minimum outflow as a function of current outflow. Designed to result in the lesser of 1 foot per day tailwater change or a 50 percent reduction in flow per the NMFS 2008 BiOp.
- *Con Max* - Normal maximum outflow during the conservation season as a function of date. Rule limits drafting to meet minimum flows at Salem and Albany.
- *Medium Fish Horn Minimum* - Typical minimum fish horn flow.
- *Albany BiOp Minimum by WY* – NMFS 2008 BiOp minimum flow target at Albany.
- *Salem BiOp Minimum by WY* – NMFS 2008 BiOp minimum flow target at Salem.
- *BiOp Minimum* – NMFS 2008 BiOp minimum tributary flows.

Willamette Valley System Operations and Maintenance Environmental Impact Statement

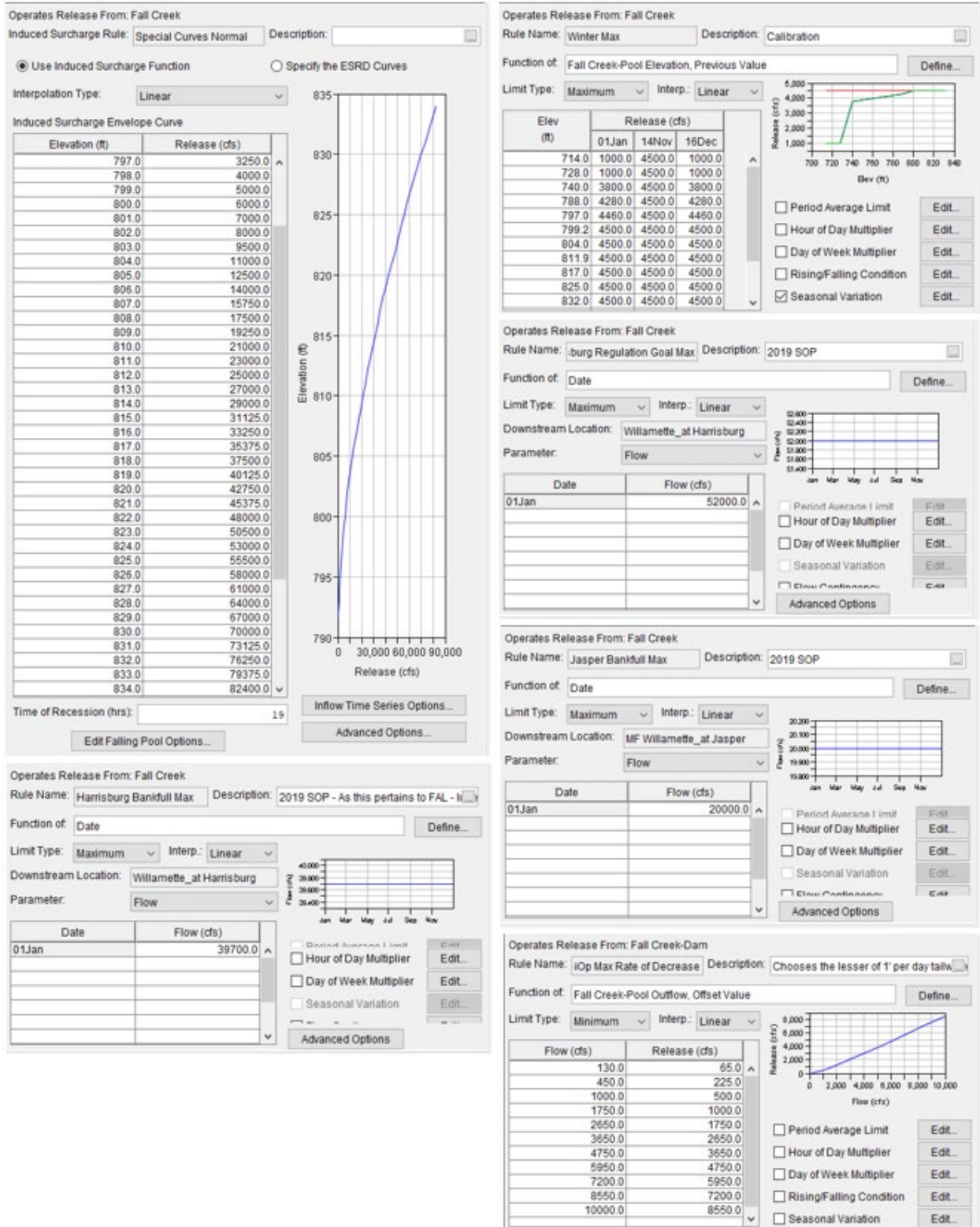

Figure 3-30. Fall Creek Dam and Reservoir NAA Operation Set Rules.

Willamette Valley System Operations and Maintenance Environmental Impact Statement

Operates Release From: Fall Creek

Rule Name: Medium Fish Horn Min Description: []

Function of: Date Define...

Limit Type: Minimum Interp.: Step

Date	Release (cfs)
01Jan	0.0
15Mar	120.0
16Oct	0.0

Period Average Limit Edit...

Hour of Day Multiplier Edit...

Day of Week Multiplier Edit...

Rising/Falling Condition Edit...

Seasonal Variation Edit...

Operates Release From: Fall Creek

Rule Name: BIOP Min Description: 2019 SOP

Function of: Date Define...

Limit Type: Minimum Interp.: Step

Date	Release (cfs)
01Jan	50.0
01Feb	50.0
01Apr	80.0
01Sep	200.0
16Oct	50.0

Period Average Limit Edit...

Hour of Day Multiplier Edit...

Day of Week Multiplier Edit...

Rising/Falling Condition Edit...

Seasonal Variation Edit...

Operates Release From: Fall Creek-Dam

Rule Name: lb and Withdrawals by WY Description: []

Function of: Water Year Type, Current Value Define...

Limit Type: Minimum Interp.: Linear

Water Year Type	Release (cfs)												
	01Jan	01Feb	01Mar	01Apr	01May	01Jun	01Jul	01Aug	01Sep	01Oct	16Oct	01Nov	01Dec
0.0	50.0	50.0	50.0	80.0	80.0	88.0	90.0	96.0	213.0	200.0	50.0	50.0	50.0
0.9	50.0	50.0	50.0	80.0	80.0	92.0	96.0	96.0	213.0	200.0	50.0	50.0	50.0
1.2	50.0	50.0	50.0	80.0	80.0	95.0	100.0	100.0	217.0	200.0	50.0	50.0	50.0
1.48	50.0	50.0	50.0	80.0	80.0	98.0	103.0	103.0	219.0	200.0	50.0	50.0	50.0
2.0	50.0	50.0	50.0	80.0	80.0	98.0	103.0	103.0	219.0	200.0	50.0	50.0	50.0

Period Average Limit Edit...

Hour of Day Multiplier Edit...

Day of Week Multiplier Edit...

Rising/Falling Condition Edit...

Seasonal Variation Edit...

Operates Release From: Fall Creek

Rule Name: Albany BIOP Min by WY Description: []

Function of: Water Year Type, Current Value Define...

Limit Type: Minimum Interp.: Linear

Downstream Location: Willamette_at Albany

Parameter: Flow

Water Year Type	Flow (cfs)											
	01Jan	01Apr	16Apr	01May	01Jun	16Jun	01Jul	01Aug	16Aug	01Sep	01Oct	01Nov
0.0	0.0	0.0	0.0	0.0	4000.0	4000.0	4000.0	4000.0	4000.0	4000.0	4000.0	0.0
0.9	0.0	0.0	0.0	0.0	4000.0	4000.0	4000.0	4000.0	4000.0	4000.0	4000.0	0.0
1.2	0.0	0.0	0.0	0.0	4500.0	4500.0	4500.0	4500.0	4500.0	4500.0	4500.0	0.0
1.48	0.0	0.0	0.0	0.0	4500.0	4500.0	4500.0	5000.0	5000.0	5000.0	5000.0	0.0
2.0	0.0	0.0	0.0	0.0	4500.0	4500.0	4500.0	5000.0	5000.0	5000.0	5000.0	0.0

Period Average Limit Edit...

Hour of Day Multiplier Edit...

Day of Week Multiplier Edit...

Seasonal Variation Edit...

Flow Continuity Edit...

Advanced Options

Operates Release From: Fall Creek

Rule Name: Salem BIOP Min by WY Description: []

Function of: Water Year Type, Current Value Define...

Limit Type: Minimum Interp.: Linear

Downstream Location: Willamette_at Salem

Parameter: Flow

Year Type	Flow (cfs)											
	01Jan	01Apr	16Apr	01May	01Jun	16Jun	01Jul	01Aug	16Aug	01Sep	01Oct	01Nov
0.0	0.0	15000.0	15000.0	15000.0	11000.0	5500.0	5000.0	5000.0	5000.0	5000.0	5000.0	0.0
0.9	0.0	15000.0	15000.0	15000.0	11000.0	5500.0	5000.0	5000.0	5000.0	5000.0	5000.0	0.0
1.2	0.0	17800.0	17800.0	15000.0	13000.0	8700.0	6000.0	6000.0	6500.0	7000.0	7000.0	0.0
1.48	0.0	17800.0	17800.0	15000.0	13000.0	8700.0	6000.0	6000.0	6500.0	7000.0	7000.0	0.0
2.0	0.0	17800.0	17800.0	15000.0	13000.0	8700.0	6000.0	6000.0	6500.0	7000.0	7000.0	0.0

Period Average Limit Edit...

Hour of Day Multiplier Edit...

Day of Week Multiplier Edit...

Seasonal Variation Edit...

Flow Continuity Edit...

Advanced Options

Figure 3-31. Fall Creek Dam and Reservoir NAA Operation Set Rules, Continued.

3.5.6 Hills Creek Dam and Reservoir Modeled Operations

3.5.6.1 Hills Creek Dam and Reservoir Operational Summary

A summary of reservoir zones, operations defined for each zone, and each zone’s role in reservoir regulation is identified in Figure 3-32. Operations only apply to the zone where they are located. The higher the location of an operation in a zone the higher the priority of that operation.

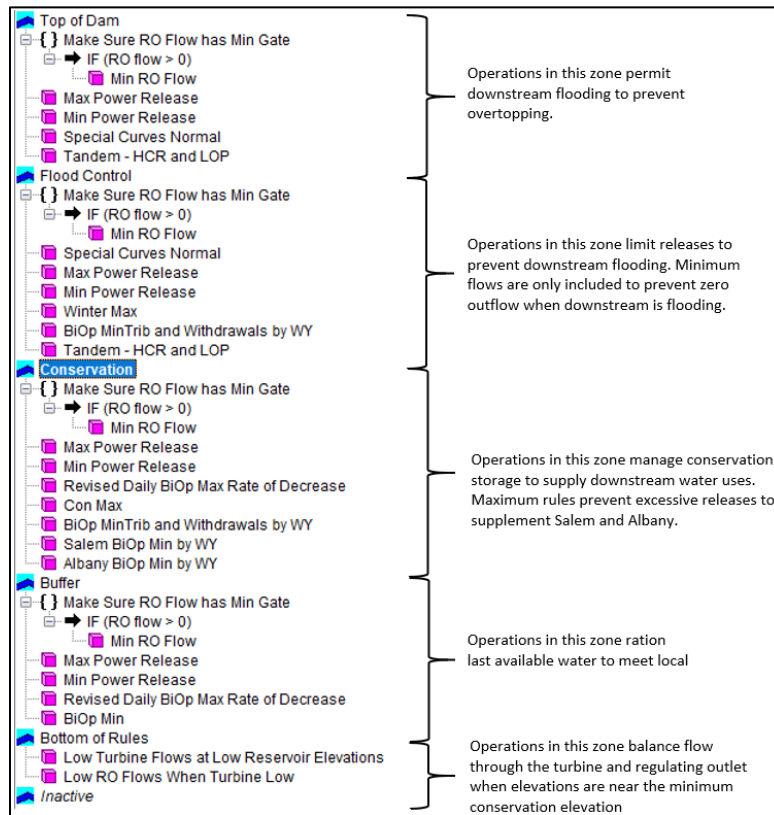
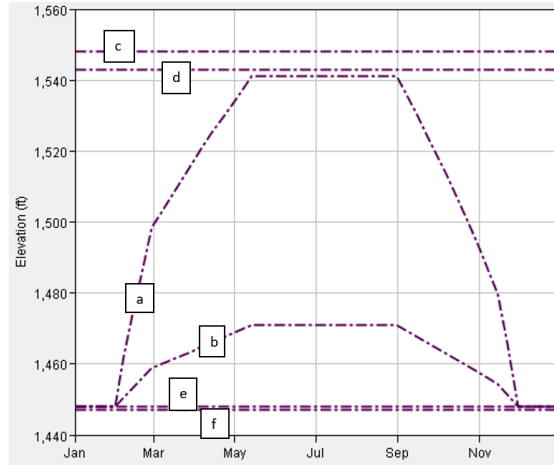

Figure 3-32. Hills Creek Dam and Reservoir Operational Summary.

3.5.6.2 Hills Creek Dam and Reservoir HEC-ResSim Water Control Diagram

A water control diagram, including all zones in HEC-ResSim, is provided in Figure 3-33. A table detailing seasonal zone elevations is provided in Table 3-18. Hills Creek Dam and Reservoir currently (August 2020) has an Interim Risk Reduction Measure (IRRM) pool restriction, but this pool restriction is not in the NAA because it is interim. All zones are defined in the project’s water control manual except for the buffer zone and 50 percent FC Pool. The 50 percent FC Pool allows for different flood control rules when at lower elevations in the flood zone. The buffer zone is for modeling purposes intended to estimate likely conservation actions taken by regulators in extremely low storage situations when local tributary flows would be prioritized above withdrawals and mainstem flow targets.

*Willamette Valley System Operations and Maintenance
Environmental Impact Statement*



**Figure 3-33. Hills Creek Dam and Reservoir HEC-ResSim
Water Control Diagram.**

Table 3-18. Hills Creek Reservoir Zone Elevations.

Conservation Zone (a)	Elevation, feet
1-Jan	1,448.1
31-Jan	1,448.1
7-Feb	1,462.2
14-Feb	1,475.2
21-Feb	1,487.2
28-Feb	1,498.4
7-Mar	1,502.7
15-Mar	1,507.6
23-Mar	1,512.4
31-Mar	1,517.1
7-Apr	1,521.1
15-Apr	1,525.6
22-Apr	1,529.4
30-Apr	1,533.7
7-May	1,537.4
14-May	1,541.0
31-Aug	1,541.0
7-Sep	1,536.1
15-Sep	1,530.3
22-Sep	1,525.1
30-Sep	1,519.0
7-Oct	1,513.5
15-Oct	1,507.0
23-Oct	1,500.4
31-Oct	1,493.4
7-Nov	1,487.2

*Willamette Valley System Operations and Maintenance
Environmental Impact Statement*

Conservation Zone (a)	Elevation, feet
15-Nov	1,479.7
22-Nov	1,465.7
30-Nov	1,448.1
Buffer Zone (b)	Elevation, feet
1-Jan	1,448.0
31-Jan	1,448.0
28-Feb	1,458.9
31-Mar	1,463.8
1-Apr	1,464.0
14-May	1,470.8
31-Aug	1,470.8
31-Oct	1,457.7
15-Nov	1,454.5
30-Nov	1,448.0
31-Dec	1,448.0
Top of Dam Zone (c)	Elevation, feet
All Year	1,548
Flood Control Zone (d)	Elevation, feet
All Year	1,543
Bottom of Rules Zone (e)	Elevation, feet
All Year	1,448
Inactive Zone (f)	Elevation, feet
All Year	1,447.0

3.5.6.3 Hills Creek Dam and Reservoir Detailed Operational Descriptions

A description of each operation at Hills Creek Dam and Reservoir is provided below followed by detailed screenshots of each operation in Figure 3-34, Figure 3-35, and Figure 3-36.

- *Minimum Regulating Outlet Flow* - Minimum flow from regulating outlet based on minimum gate opening.
- *Maximum Power Release* - Maximum flow through powerhouse.
- *Minimum Power Release* - Minimum flow through powerhouse, but different than speed no load.
- *Special Curves Normal* - induced surcharge function, a function of elevation and inflow. Designed for flood events that present risk of dam overtopping.
- *Tandem - HCR and LOP* - Helps Hills Creek and Lookout Point Dams and Reservoirs balance storage.
- *Winter Maximum* - Maximum release as a function of pool elevation. Designed to mimic flood season maximum releases.

*Willamette Valley System Operations and Maintenance
Environmental Impact Statement*

- *BiOp MinTrib and Withdrawals by WY* - Includes minimum flows to satisfy the NMFS 2008 BiOp and 2050 projected consumptive withdrawals.
- *Revised Daily BiOp Maximum Rate of Decrease* - Defines the next day's minimum outflow as a function of current outflow. Designed to result in the lesser of 1 foot per day tailwater change or a 50 percent reduction in flow per the NMFS 2008 BiOp.
- *Con Max* - Maximum outflow during the conservation season as a function of date. Rule limits drafting to meet minimum flows at Salem and Albany.
- *Salem BiOp Minimum by WY* – NMFS 2008 BiOp minimum flow target at Salem.
- *Albany BiOp Minimum by WY* – NMFS 2008 BiOp minimum flow target at Albany.
- *BiOp Minimum* – NMFS 2008 BiOp minimum tributary flow.
- *Low Turbine Flows at Low Reservoir Elevations* - Balances flow through the turbine and regulating outlet when pool elevations are very low.
- *Low Regulating Outlet Flows When Turbine Low* - Balances flow through the turbine and regulating outlet when pool elevations are very low.

*Willamette Valley System Operations and Maintenance
Environmental Impact Statement*

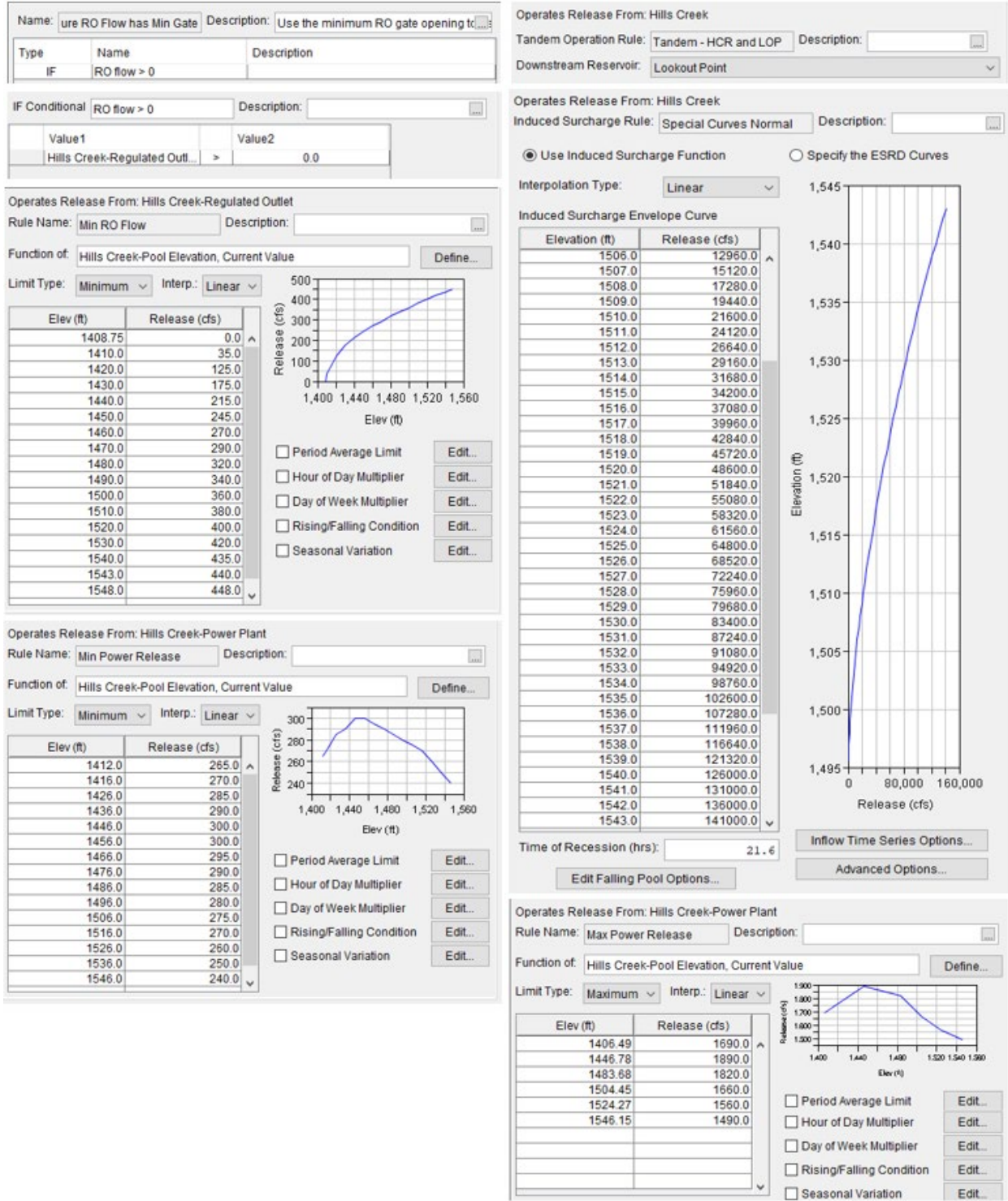

Figure 3-34. Hills Creek Dam and Reservoir NAA Operation Set Rules.

*Willamette Valley System Operations and Maintenance
Environmental Impact Statement*

Operates Release From: Hills Creek-Dam
 Rule Name: Description:

Function of: Define...

Limit Type: Interp.:

Water Year Type	Release (cfs)											
	01Jan	01Feb	01Mar	01Apr	01May	01Jun	01Jul	01Aug	01Sep	01Oct	01Nov	01Dec
0.0	400.0	400.0	400.0	400.0	400.0	413.0	417.0	418.0	415.0	400.0	400.0	400.0
0.9	400.0	400.0	400.0	400.0	400.0	421.0	427.0	428.0	423.0	400.0	400.0	400.0
1.2	400.0	400.0	400.0	400.0	400.0	426.0	434.0	435.0	429.0	400.0	400.0	400.0
1.48	400.0	400.0	400.0	400.0	400.0	431.0	440.0	440.0	433.0	400.0	400.0	400.0
2.0	400.0	400.0	400.0	400.0	400.0	431.0	440.0	440.0	433.0	400.0	400.0	400.0

Period Average Limit Edit...
 Hour of Day Multiplier Edit...
 Day of Week Multiplier Edit...
 Rising/Falling Condition Edit...
 Seasonal Variation Edit...

Operates Release From: Hills Creek
 Rule Name: Description:

Function of: Define...

Limit Type: Interp.:

Downstream Location: Parameter:

Water Year Type	Flow (cfs)											
	01Jan	01Apr	16Apr	01May	01Jun	16Jun	01Jul	01Aug	16Aug	01Sep	01Oct	01Nov
0.0	0.0	15000.0	15000.0	15000.0	11000.0	5500.0	5000.0	5000.0	5000.0	5000.0	5000.0	0.0
0.9	0.0	15000.0	15000.0	15000.0	11000.0	5500.0	5000.0	5000.0	5000.0	5000.0	5000.0	0.0
1.2	0.0	17800.0	17800.0	15000.0	13000.0	8700.0	6000.0	6000.0	6500.0	7000.0	7000.0	0.0
1.48	0.0	17800.0	17800.0	15000.0	13000.0	8700.0	6000.0	6000.0	6500.0	7000.0	7000.0	0.0
2.0	0.0	17800.0	17800.0	15000.0	13000.0	8700.0	6000.0	6000.0	6500.0	7000.0	7000.0	0.0

Period Average Limit Edit...
 Hour of Day Multiplier Edit...
 Day of Week Multiplier Edit...
 Seasonal Variation Edit...

Operates Release From: Hills Creek
 Rule Name: Description:

Function of: Define...

Limit Type: Interp.:

Downstream Location: Parameter:

Water Year Type	Flow (cfs)											
	01Jan	01Apr	16Apr	01May	01Jun	16Jun	01Jul	01Aug	16Aug	01Sep	01Oct	01Nov
0.0	0.0	0.0	0.0	0.0	4000.0	4000.0	4000.0	4000.0	4000.0	4000.0	4000.0	0.0
0.9	0.0	0.0	0.0	0.0	4000.0	4000.0	4000.0	4000.0	4000.0	4000.0	4000.0	0.0
1.2	0.0	0.0	0.0	0.0	4500.0	4500.0	4500.0	4500.0	4500.0	4500.0	4500.0	0.0
1.48	0.0	0.0	0.0	0.0	4500.0	4500.0	4500.0	5000.0	5000.0	5000.0	5000.0	0.0
2.0	0.0	0.0	0.0	0.0	4500.0	4500.0	4500.0	5000.0	5000.0	5000.0	5000.0	0.0

Period Average Limit Edit...
 Hour of Day Multiplier Edit...
 Day of Week Multiplier Edit...
 Seasonal Variation Edit...

Figure 3-35. Hills Creek Dam and Reservoir NAA Operation Set Rules, Continued.

*Willamette Valley System Operations and Maintenance
Environmental Impact Statement*

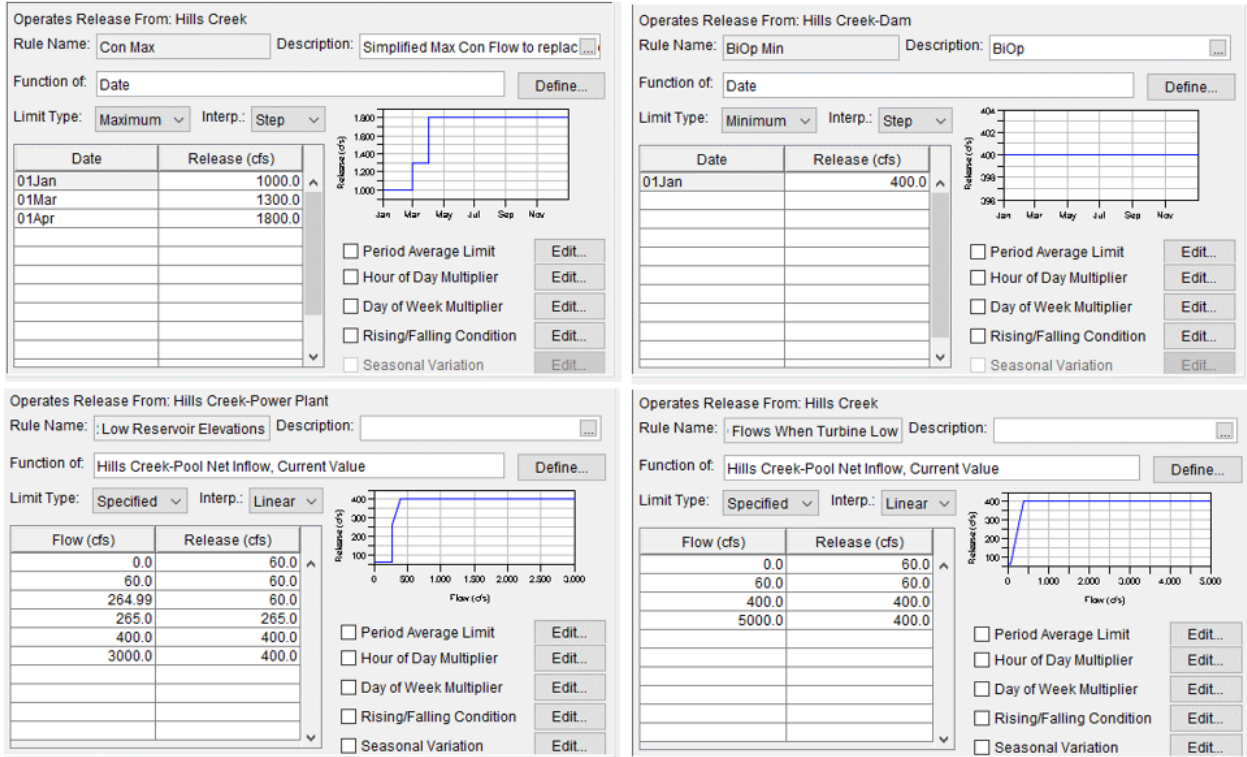

Figure 3-36. Hills Creek Dam and Reservoir NAA Operation Set Rules, Continued.

3.5.7 Lookout Point Dam and Reservoir Modeled Operations

3.5.7.1 Lookout Point Dam and Reservoir Operational Summary

A summary of reservoir zones, operations defined for each zone, and each zone’s role in reservoir regulation is identified in Figure 3-37. Operations only apply to the zone where they are located. The higher the location of an operation in a zone the higher the priority of that operation.

*Willamette Valley System Operations and Maintenance
Environmental Impact Statement*

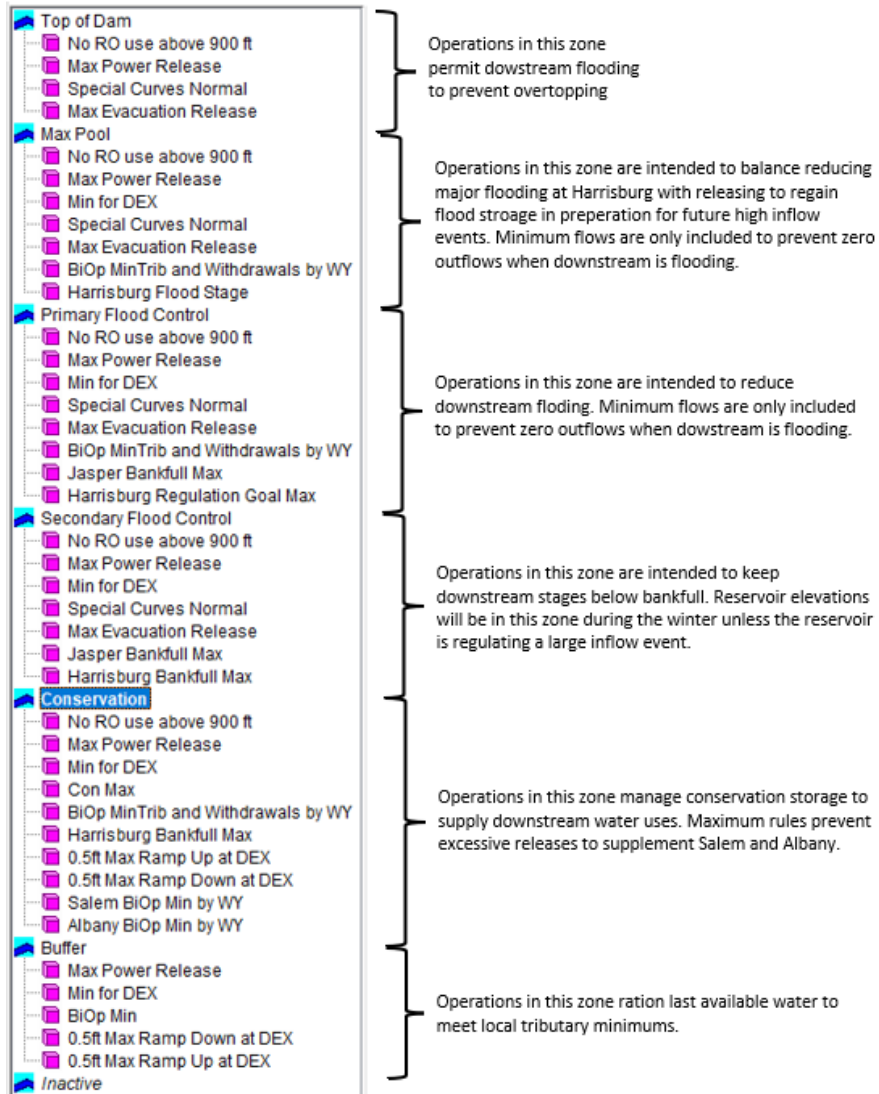

Figure 3-37. Lookout Point Dam and Reservoir Operational Summary.

3.5.7.2 Lookout Point Dam and Reservoir HEC-ResSim Water Control Diagram

A water control diagram, including all zones in HEC-ResSim, for Lookout Point Dam and Reservoir is provided in Figure 3-38. A table detailing seasonal zone elevations is provided in Table 3-19. Lookout Point Dam and Reservoir currently (August 2020) has an Interim Risk Reduction Measure (IRRM) pool restriction, but this pool restriction is not in the NAA because it is interim. All zones are defined in the project’s water control manual except for the buffer zone and bottom of rules. The buffer zone is for modeling purposes intended to estimate likely conservation actions taken by regulators in extremely low storage situations when local tributary flows would be prioritized above withdrawals and mainstem flow targets. The bottom of rules zone balances turbine and regulating outlet flow when at the boundary of the inactive zone, which is also the top of the power pool. Dexter Dam and Reservoir re-regulates Lookout Point Dam and Reservoir outflows. Average daily outflow from Dexter Dam and Reservoir is the same as the average daily outflow from Lookout Point Dam and Reservoir. In HEC-ResSim,

*Willamette Valley System Operations and Maintenance
Environmental Impact Statement*

which is a daily model, Dexter Dam and Reservoir has no defined operations and passes inflow from Lookout Point Dam and Reservoir.

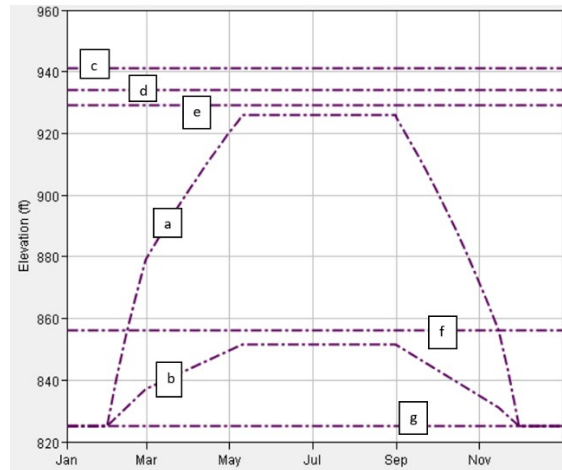

Figure 3-38. Lookout Point Dam and Reservoir HEC-ResSim Water Control Diagram.

Table 3-19. Lookout Point Reservoir Zone Elevations.

Conservation Zone (a)	Elevation, feet
1-Jan	825.1
31-Jan	825.1
7-Feb	841.1
14-Feb	855.2
21-Feb	867.6
28-Feb	879.0
7-Mar	884.3
15-Mar	890.0
23-Mar	895.6
31-Mar	901.0
7-Apr	905.6
15-Apr	910.7
22-Apr	915.0
30-Apr	920.0
7-May	924.0
10-May	926.0
31-Aug	926.0
1-Sep	925.0
15-Sep	914.1
22-Sep	908.4
30-Sep	901.6
7-Oct	895.4
15-Oct	888.1

*Willamette Valley System Operations and Maintenance
Environmental Impact Statement*

Conservation Zone (a)	Elevation, feet
23-Oct	880.5
31-Oct	872.5
7-Nov	865.1
15-Nov	856.1
22-Nov	842.7
30-Nov	825.1
Buffer Zone (b)	Elevation, feet
1-Jan	825.0
31-Jan	825.0
28-Feb	837.0
10-May	851.6
31-Aug	851.6
30-Sep	843.5
15-Nov	831.2
30-Nov	825.0
Top of Dam Zone (c)	Elevation, feet
All Year	941
Max Pool Zone (d)	Elevation, feet
All Year	934
Primary Flood Control Zone (e)	Elevation, feet
All Year	929
Secondary Flood Control Zone (f)	Elevation, feet
All Year	856.0
Inactive Zone (g)	Elevation, feet
All Year	825.0

3.5.7.3 Lookout Point Dam and Reservoir Detailed Operational Descriptions

A description of each operation at Lookout Point Dam and Reservoir is provided below followed by detailed screenshots of each operation in Figure 3-39, Figure 3-40, and Figure 3-41.

- *No Regulating Outlet use above 900 ft* - Regulating outlet cannot be used above 900 feet.
- *Maximum Power Release* - Maximum flow through powerhouse.
- *Minimum Power Release* - Minimum flow through powerhouse, but different than speed no load.
- *Special Curves Normal* - induced surcharge function, a function of elevation and inflow. Designed for flood events that present risk of dam overtopping.
- *Maximum Evacuation Release* – Maximum release as a function of pool elevation. Designed to mimic flood season maximum releases.

*Willamette Valley System Operations and Maintenance
Environmental Impact Statement*

- *Minimum for DEX* – Minimum daily average outflow from LOP to prevent cavitation at DEX power plant.
- *BiOp MinTrib and Withdrawals by WY* - Includes minimum flows to satisfy the NMFS 2008 BiOp and 2050 projected consumptive withdrawals.
- *Harrisburg Flood Stage* - Harrisburg flood flow is 66,500 cfs.
- *Jasper Bankfull Maximum* - Jasper bankfull flow is 20,000 cfs.
- *Harrisburg Regulation Goal Maximum* - Harrisburg regulation goal is 52,000 cfs.
- *Con Max* - Maximum outflow during the conservation season as a function of date. Rule limits drafting to meet minimum flows at Salem and Albany.
- *0.5ft Maximum Ramp Up at DEX* - Ramping rate restriction for Dexter Dam and Reservoir.
- *0.5ft Maximum Ramp Down at DEX* - Ramping rate restriction for Dexter Dam and Reservoir, which is stricter than the NMFS 2008 BiOp requirement.
- *Salem BiOp Minimum by WY* – NMFS 2008 BiOp minimum flow target at Salem.
- *Albany BiOp Minimum by WY* – NMFS 2008 BiOp minimum flow target at Albany.
- *BiOp Minimum* – NMFS 2008 BiOp minimum tributary flow.

*Willamette Valley System Operations and Maintenance
Environmental Impact Statement*

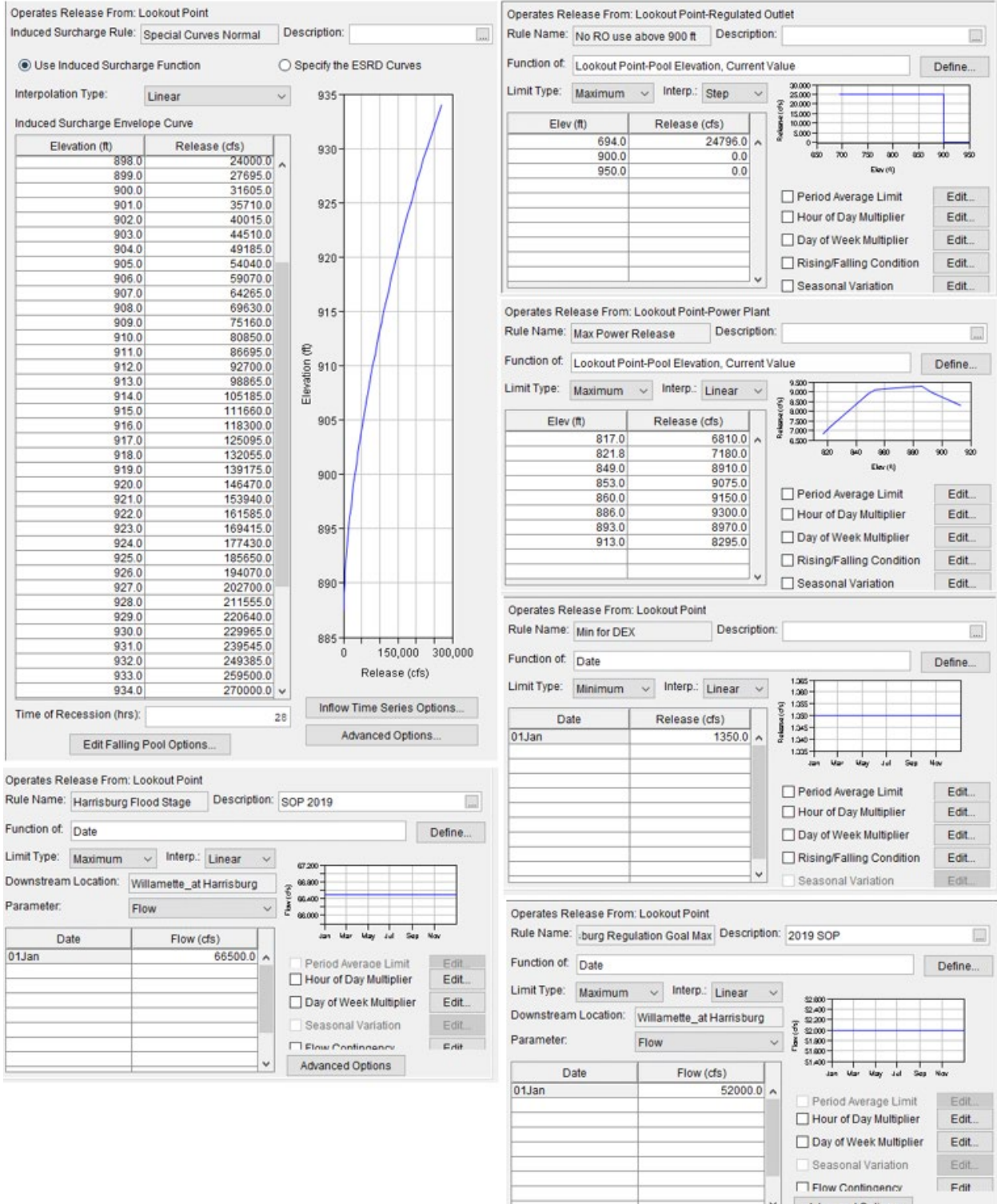

Figure 3-39. Lookout Point Dam and Reservoir NAA Operation Set Rules.

*Willamette Valley System Operations and Maintenance
Environmental Impact Statement*

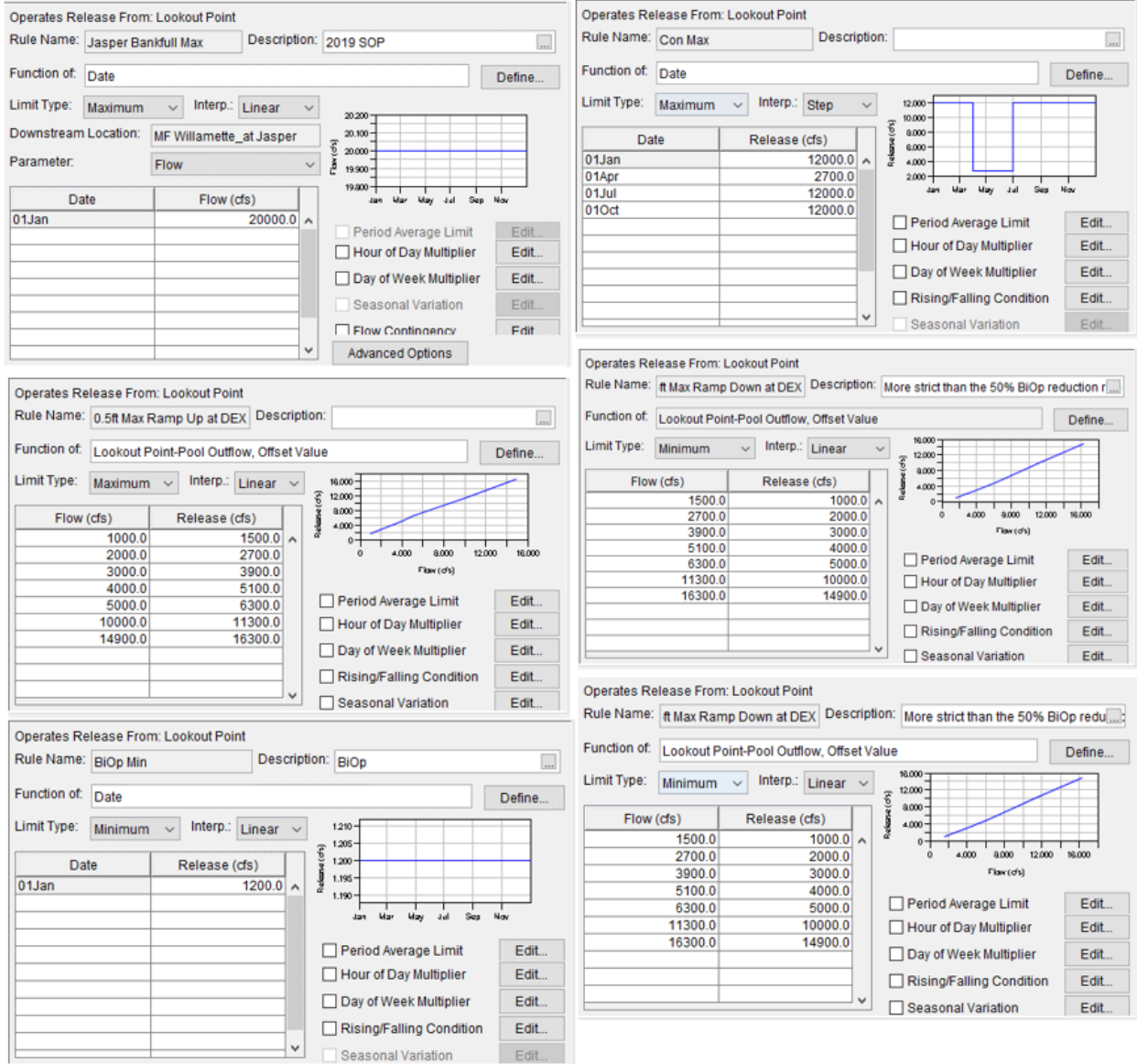

Figure 3-40. Lookout Point Dam and Reservoir NAA Operation Set Rules, Continued.

*Willamette Valley System Operations and Maintenance
Environmental Impact Statement*

Operates Release From: Lookout Point-Dam

Rule Name: **ib and Withdrawals by WY** Description: 1350 CFS is required to prevent cavitation at Dexter and is greater than BIOP + consumptive withdrawals

Function of: Water Year Type, Current Value

Limit Type: Minimum Interp.: Linear

Water Year Type	Release (cfs)											
	01Jan	01Feb	01Mar	01Apr	01May	01Jun	01Jul	01Aug	01Sep	01Oct	01Nov	01Dec
0.0	1200.0	1200.0	1200.0	1200.0	1200.0	1222.0	1229.0	1230.0	1224.0	1200.0	1200.0	1200.0
0.9	1200.0	1200.0	1200.0	1200.0	1200.0	1235.0	1246.0	1247.0	1238.0	1200.0	1200.0	1200.0
1.2	1200.0	1200.0	1200.0	1200.0	1200.0	1244.0	1257.0	1258.0	1248.0	1200.0	1200.0	1200.0
1.48	1200.0	1200.0	1200.0	1200.0	1200.0	1251.0	1266.0	1267.0	1256.0	1200.0	1200.0	1200.0
2.0	1200.0	1200.0	1200.0	1200.0	1200.0	1251.0	1266.0	1267.0	1256.0	1200.0	1200.0	1200.0

Period Average Limit Edit...

Hour of Day Multiplier Edit...

Day of Week Multiplier Edit...

Rising/Falling Condition Edit...

Seasonal Variation Edit...

Operates Release From: Lookout Point

Rule Name: **Salem BIOP Min by WY** Description:

Function of: Water Year Type, Current Value

Limit Type: Minimum Interp.: Linear

Downstream Location: Willamette_at Salem

Parameter: Flow

Water Year Type	Flow (cfs)											
	01Jan	01Apr	16Apr	01May	01Jun	16Jun	01Jul	01Aug	16Aug	01Sep	01Oct	01Nov
0.0	0.0	15000.0	15000.0	15000.0	11000.0	5500.0	5000.0	5000.0	5000.0	5000.0	5000.0	0.0
0.9	0.0	15000.0	15000.0	15000.0	11000.0	5500.0	5000.0	5000.0	5000.0	5000.0	5000.0	0.0
1.2	0.0	17800.0	17800.0	15000.0	13000.0	8700.0	6000.0	6000.0	6500.0	7000.0	7000.0	0.0
1.48	0.0	17800.0	17800.0	15000.0	13000.0	8700.0	6000.0	6000.0	6500.0	7000.0	7000.0	0.0
2.0	0.0	17800.0	17800.0	15000.0	13000.0	8700.0	6000.0	6000.0	6500.0	7000.0	7000.0	0.0

Period Average Limit Edit...

Hour of Day Multiplier Edit...

Day of Week Multiplier Edit...

Seasonal Variation Edit...

Rising/Falling Condition Edit...

Advanced Options

Operates Release From: Lookout Point

Rule Name: **Albany BIOP Min by WY** Description:

Function of: Water Year Type, Current Value

Limit Type: Minimum Interp.: Linear

Downstream Location: Willamette_at Albany

Parameter: Flow

Water Year Type	Flow (cfs)											
	01Jan	01Apr	16Apr	01May	01Jun	16Jun	01Jul	01Aug	16Aug	01Sep	01Oct	01Nov
0.0	0.0	0.0	0.0	0.0	4000.0	4000.0	4000.0	4000.0	4000.0	4000.0	4000.0	0.0
0.9	0.0	0.0	0.0	0.0	4000.0	4000.0	4000.0	4000.0	4000.0	4000.0	4000.0	0.0
1.2	0.0	0.0	0.0	0.0	4500.0	4500.0	4500.0	4500.0	4500.0	4500.0	4500.0	0.0
1.48	0.0	0.0	0.0	0.0	4500.0	4500.0	4500.0	5000.0	5000.0	5000.0	5000.0	0.0
2.0	0.0	0.0	0.0	0.0	4500.0	4500.0	4500.0	5000.0	5000.0	5000.0	5000.0	0.0

Period Average Limit Edit...

Hour of Day Multiplier Edit...

Day of Week Multiplier Edit...

Seasonal Variation Edit...

Rising/Falling Condition Edit...

Advanced Options

Figure 3-41. Lookout Point Dam and Reservoir NAA Operation Set Rules, Continued.

3.5.8 Fern Ridge Dam and Reservoir Modeled Operations

3.5.8.1 Fern Ridge Dam and Reservoir Operational Summary

A summary of reservoir zones, operations defined for each zone, and each zone’s role in reservoir regulation is identified in Figure 3-42. Operations only apply to the zone where they are located. The higher the location of an operation in a zone the higher the priority of that operation.

*Willamette Valley System Operations and Maintenance
Environmental Impact Statement*

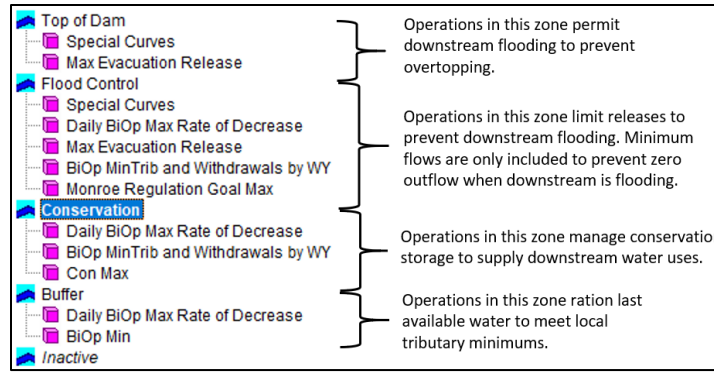

Figure 3-42. Fern Ridge Dam and Reservoir Operational Summary.

3.5.8.2 Fern Ridge Dam and Reservoir HEC-ResSim Water Control Diagram

A water control diagram, including all zones in HEC-ResSim, for Fern Ridge Dam and Reservoir is provided in Figure 3-43. A table detailing seasonal zone elevations is provided in Table 3-20. All zones are defined in the project’s water control manual except for the buffer zone. The buffer zone is for modeling purposes intended to estimate likely conservation actions taken by regulators in extremely low storage situations when local tributary flows would be prioritized above withdrawals and mainstem flow targets.

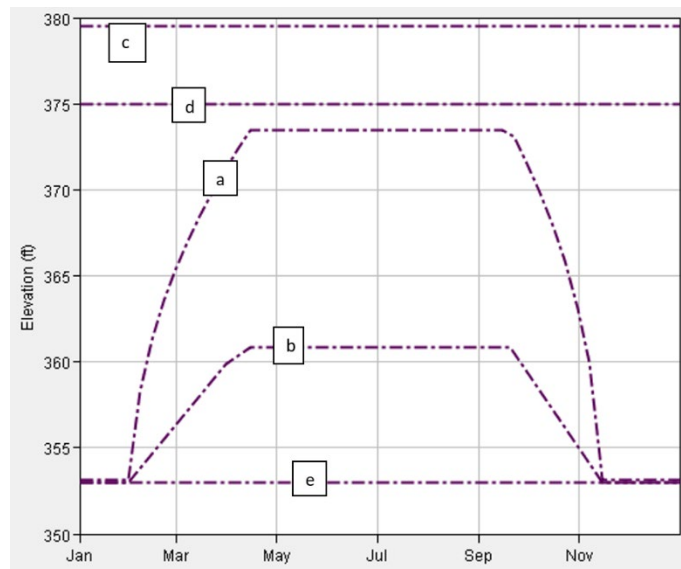

Figure 3-43. Fern Ridge Dam and Reservoir HEC-ResSim Water Control Diagram.

*Willamette Valley System Operations and Maintenance
Environmental Impact Statement*

Table 3-20. Fern Ridge Reservoir Zone Elevations.

Conservation Zone (a)	Elevation, feet
1-Jan	353.1
31-Jan	353.1
7-Feb	358.3
14-Feb	361.2
21-Feb	363.5
28-Feb	365.3
7-Mar	366.9
15-Mar	368.5
23-Mar	369.9
31-Mar	371.2
7-Apr	372.3
15-Apr	373.5
15-Sep	373.5
22-Sep	373.1
30-Sep	371.5
7-Oct	370.0
15-Oct	368.1
23-Oct	365.9
31-Oct	363.1
7-Nov	359.9
15-Nov	353.1
Buffer Zone (b)	Elevation, feet
1-Jan	353.0
31-Jan	353.0
31-Mar	359.9
15-Apr	360.9
30-Jun	360.9
20-Sep	360.9
15-Nov	353.0
31-Dec	353.0
Top of Dam Zone (c)	Elevation, feet
All Year	379.5
Flood Control Zone (d)	Elevation, feet
All Year	375
Inactive Zone (e)	Elevation, feet
All Year	353

3.5.8.3 Fern Ridge Dam and Reservoir Detailed Operational Descriptions

A description of each operation at Fern Ridge Dam and Reservoir is provided below followed by detailed screenshots of each operation in Figure 3-44.

*Willamette Valley System Operations and Maintenance
Environmental Impact Statement*

- *Special Curves* - Induced surcharge function, a function of elevation and inflow. Designed for flood events that present risk of dam overtopping.
- *Maximum Evacuation Release* - Maximum release as a function of pool elevation. Designed to mimic flood season maximum releases.
- *Daily BiOp Maximum Rate of Decrease* - Defines the next day's minimum outflow as a function of current outflow. Designed to result in the lesser of 1 foot per day tailwater change or a 50 percent reduction in flow per the NMFS 2008 BiOp.
- *BiOp MinTrib and Withdrawals by WY* - Includes minimum flows to satisfy the NMFS 2008 BiOp and 2050 projected consumptive withdrawals.
- *Monroe Regulation Goal Maximum* - Function of Fern Ridge elevation. Target below bankfull when elevations are low, and flood stage when elevations are high.
- *Con Max* - Normal maximum outflow during the conservation season as a function of date. Rule limits drafting to meet minimum flows at Salem and Albany.
- *BiOp Minimum* – NMFS 2008 BiOp minimum tributary flows.

Willamette Valley System Operations and Maintenance
Environmental Impact Statement

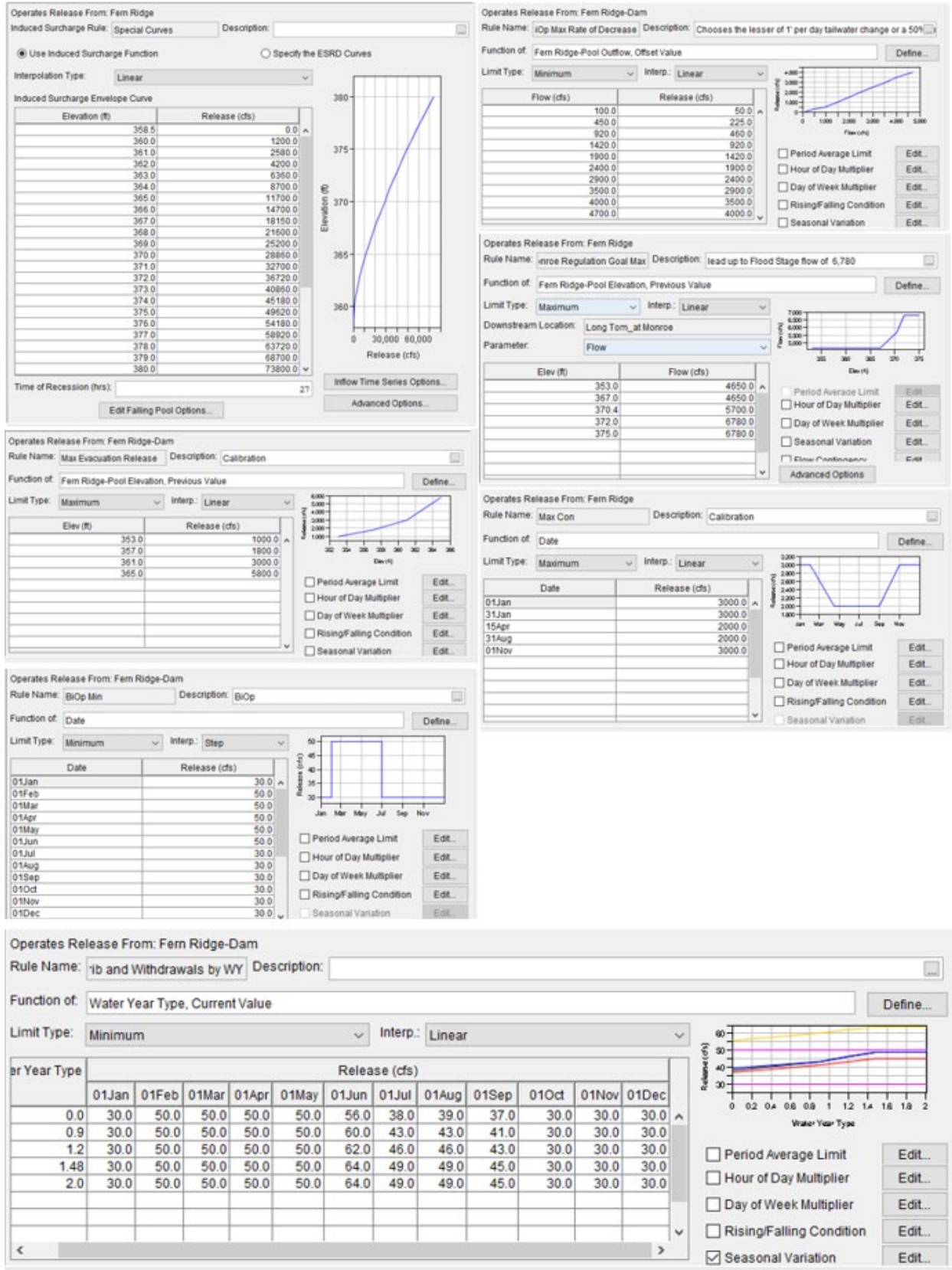

Figure 3-44. Fern Ridge Dam and Reservoir NAA Operation Set Rules.

3.5.9 Green Peter Dam and Reservoir Modeled Operations

3.5.9.1 Green Peter Dam and Reservoir Operational Summary

A summary of reservoir zones, operations defined for each zone, and each zone’s role in reservoir regulation is identified in Figure 3-45. Operations only apply to the zone where they are located. The higher the location of an operation in a zone the higher the priority of that operation. Foster Reservoir elevations are generally prioritized above Green Peter Reservoir elevations. Many operations at Green Peter Dam and Reservoir are designed to meet targets downstream of Foster Reservoir without drafting Foster below the rule curve.

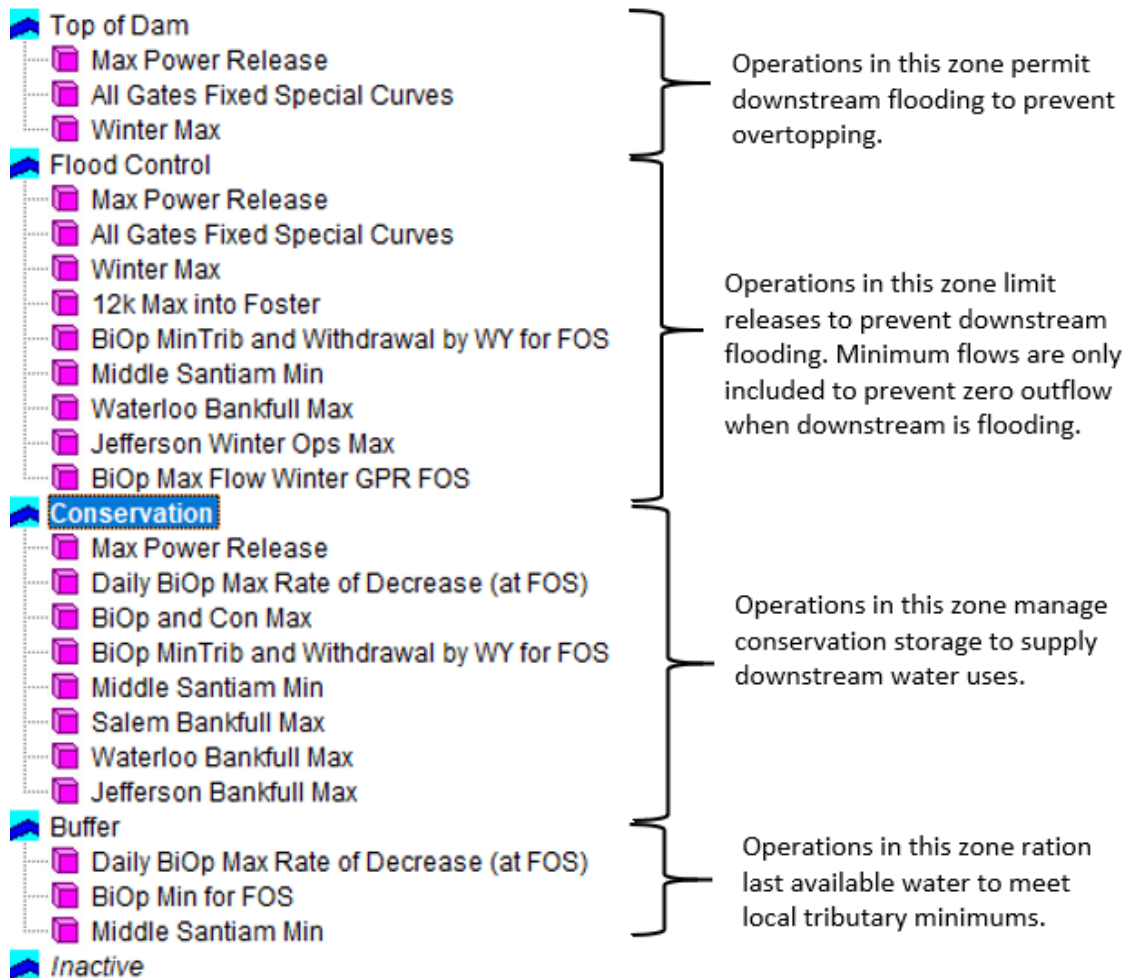

Figure 3-45. Green Peter Dam and Reservoir Operational Summary.

3.5.9.2 Green Peter Dam and Reservoir HEC-ResSim Water Control Diagram

A water control diagram including all zones in HEC-ResSim for Green Peter Dam and Reservoir is provided in Figure 3-46. A table detailing seasonal zone elevations is provided in Table 3-21. All zones are defined in the project’s water control manual except for the buffer zone. The buffer zone is for modeling purposes intended to estimate likely conservation actions taken by

*Willamette Valley System Operations and Maintenance
Environmental Impact Statement*

regulators in extremely low storage situations when local tributary flows would be prioritized above withdrawals and mainstem flow targets.

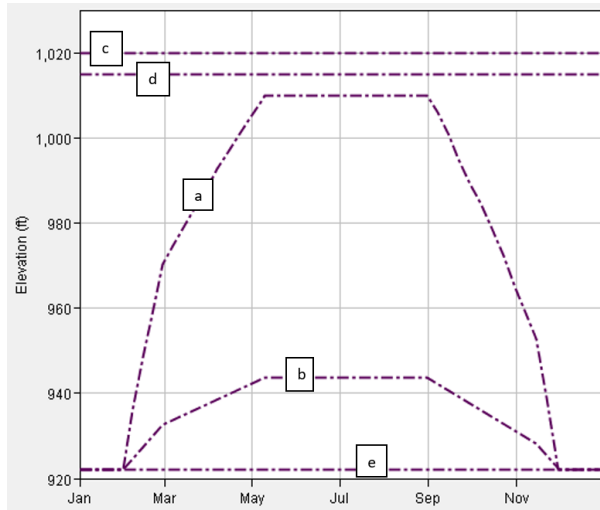

Figure 3-46. Green Peter Dam and Reservoir HEC-ResSim Water Control Diagram.

Table 3-21. Green Peter Reservoir Zone Elevations.

Conservation Zone (a)	Elevation, feet
1-Jan	922.0
31-Jan	922.0
7-Feb	935.8
14-Feb	948.3
21-Feb	959.8
28-Feb	970.4
7-Mar	974.7
15-Mar	979.4
23-Mar	984.1
31-Mar	988.7
7-Apr	992.6
15-Apr	996.9
22-Apr	1,000.7
30-Apr	1,004.9
7-May	1,008.5
10-May	1,010.0
31-Aug	1,010.0
7-Sep	1,006.0
15-Sep	1,000.5
22-Sep	994.9
30-Sep	989.1
7-Oct	984.7

*Willamette Valley System Operations and Maintenance
Environmental Impact Statement*

Conservation Zone (a)	Elevation, feet
15-Oct	978.6
23-Oct	972.4
31-Oct	964.8
7-Nov	959.6
15-Nov	952.7
22-Nov	938.9
30-Nov	922.0
7-Dec	922.0
15-Dec	922.0
23-Dec	922.0
31-Dec	922.0
Buffer Zone (b)	Elevation, feet
1-Jan	922.0
31-Jan	922.0
28-Feb	932.5
10-May	943.7
30-Jun	943.7
31-Aug	943.7
15-Nov	928.2
1-Dec	922.0
31-Dec	922.0
Top of Dam Zone (c)	Elevation, feet
All Year	1,020
Flood Control Zone (d)	Elevation, feet
All Year	1,015
Inactive Zone (e)	Elevation, feet
All Year	922

3.5.9.3 Green Peter Dam and Reservoir Detailed Operational Descriptions

A description of each operation at Green Peter Dam and Reservoir is provided below followed by detailed screenshots of each operation in Figure 3-47 and Figure 3-48.

- *Maximum Power Release* - Maximum flow through powerhouse.
- *All Gates Fixed Special Curves* - induced surcharge function, a function of elevation and inflow. Designed for flood events that present risk of dam overtopping.
- *Winter Maximum* - Maximum release as a function of pool elevation. Designed to mimic flood season maximum releases.
- *12k Maximum into Foster* – Don’t release more than 12,000 cfs into Foster.

*Willamette Valley System Operations and Maintenance
Environmental Impact Statement*

- *BiOp Min Trib and Withdrawal by WY for FOS* - Target minimum downstream of Foster Dam and Reservoir to satisfy NMFS 2008 BiOp and withdrawals.
- *Middle Santiam Min* – Minimum tributary flow of 50 cfs between Green Peter and Foster Dams and Reservoirs.
- *Waterloo Bankfull Maximum* - Waterloo bankfull flow is 19,000 cfs.
- *Jefferson Winter Ops Maximum* - allows bankfull or flood stage at Jefferson depending on elevation.
- *BiOp Maximum Spawning Flow GPR FOS* - Maximum flow in September of 3,000 cfs for spawning.
- *Daily BiOp Maximum Rate of Decrease (at FOS)* - Defines the next day's minimum outflow as a function of current outflow. Designed to result in the lesser of 1 foot per day tailwater change or a 50 percent reduction in flow per the NMFS 2008 BiOp.
- *BiOp and Con Max* - Maximum NMFS 2008 BiOp outflow in September used all conservation season as normal maximum outflow.
- *Salem Bankfull Maximum* - Salem Bankfull is 94,000 cfs.
- *Jefferson Bankfull Maximum* - Jefferson bankfull is 43,000 cfs.

*Willamette Valley System Operations and Maintenance
Environmental Impact Statement*

Operates Release From: Green Peter-Power Plant
 Rule Name: Max Power Release
 Function of: Green Peter-Pool Elevation, Current Value
 Limit Type: Maximum Interp.: Linear

Elev (ft)	Release (cfs)
881.5	4200.0
901.0	4480.0
937.1	4760.0
962.2	4860.0
967.0	4740.0
981.9	4480.0
992.7	4340.0
1021.2	4040.0

Operates Release From: Green Peter
 Rule Name: Winter Max
 Description: Calibration at lowest elevations - RO capacity at upper elevations
 Function of: Green Peter-Pool Elevation, Previous Value
 Limit Type: Maximum Interp.: Linear

Elev (ft)	Release (cfs)
922.0	4650.0
950.0	10000.0
963.0	10720.0
965.1	10840.0
967.0	12050.0
968.7	12150.0
1004.0	13000.0
1008.0	13000.0
1010.0	13000.0
1011.0	13000.0

Operates Release From: Green Peter
 Induced Surcharge Rule: ates Fixed Special Curves
 Use Induced Surcharge Function
 Interpolation Type: Linear

Induced Surcharge Envelope Curve

Elevation (ft)	Release (cfs)
978.0	8500.0
979.0	10000.0
980.0	11800.0
981.0	13680.0
982.0	15560.0
983.0	17440.0
984.0	19320.0
985.0	21200.0
986.0	23400.0
987.0	25600.0
988.0	27800.0
989.0	30000.0
990.0	32200.0
991.0	34760.0
992.0	37320.0
993.0	39880.0
994.0	42440.0
995.0	45000.0
996.0	47960.0
997.0	50920.0
998.0	53880.0
999.0	56840.0
1000.0	59800.0
1001.0	63040.0
1002.0	66280.0
1003.0	69520.0
1004.0	72760.0
1005.0	76000.0
1006.0	79360.0
1007.0	82720.0
1008.0	86080.0
1009.0	89440.0
1010.0	92800.0
1011.0	96240.0
1012.0	99680.0
1013.0	103120.0
1014.0	106560.0
1015.0	110000.0

Operates Release From: Green Peter-Dam
 Rule Name: 12k Max into Foster
 Description: 12k Max into Foster
 Function of: Foster - Flow-Loc Inc (Cascadia) Known Flow, Period Average, -0.0 hr offset, 4.0 hr period
 Limit Type: Maximum Interp.: Linear

Flow (cfs)	Release (cfs)
0.0	11500.0
5800.0	5700.0
11450.0	50.0
99999.0	50.0

Operates Release From: Green Peter
 Rule Name: Waterloo Banifull Max
 Description: 2019 SOP
 Function of: Date
 Limit Type: Maximum Interp.: Linear
 Downstream Location: So Santiam_at Waterloo
 Parameter: Flow

Date	Flow (cfs)
01-Jan	19000.0

Operates Release From: Green Peter
 Rule Name: Jefferson Winter Ops Max
 Description: 2019 SOP Banifull 43,000 flood 55,900
 Function of: Detroit-Pool Elevation, Current Value
 Limit Type: Maximum Interp.: Linear
 Downstream Location: Santiam_at Jefferson
 Parameter: Flow

Elev (ft)	Flow (cfs)
1424.0	43000.0
1536.0	43000.0
1546.0	55900.0
1574.0	55900.0

Operates Release From: Green Peter
 Rule Name: Middle Santiam Min
 Description: Middle Santiam Min
 Function of: Date
 Limit Type: Minimum Interp.: Linear

Date	Release (cfs)
01-Jan	50.0

Figure 3-47. Green Peter Dam and Reservoir NAA Operation Set Rules.

*Willamette Valley System Operations and Maintenance
Environmental Impact Statement*

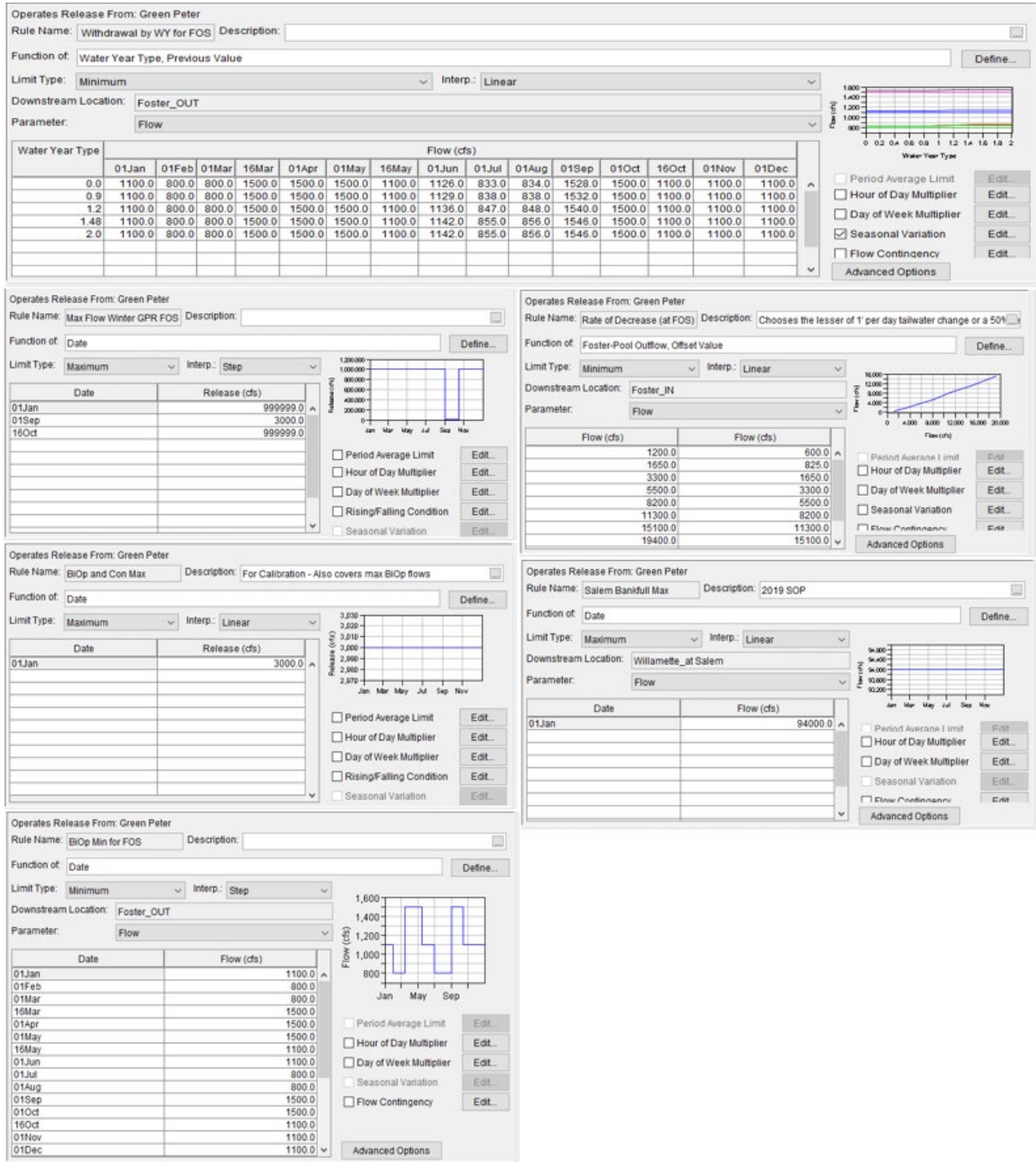

Figure 3-48. Green Peter Dam and Reservoir NAA Operation Set Rules, Continued.

3.5.10 Foster Dam and Reservoir Modeled Operations

3.5.10.1 Foster Dam and Reservoir Operational Summary

A summary of reservoir zones, operations defined for each zone, and each zone’s role in reservoir regulation is identified in Figure 3-49. Operations only apply to the zone where they

are located. The higher the location of an operation in a zone the higher the priority of that operation. Foster Reservoir elevations are generally prioritized above Green Peter Reservoir elevations; therefore, many operations at Foster Reservoir are coordinated with operations at Green Peter Reservoir. In the NAA, minimum tributary flows are defined at Green Peter Reservoir targeting the desired flow below Foster Reservoir. Foster passes inflow from Green Peter Reservoir and the South Santiam to meet its minimum outflow requirements.

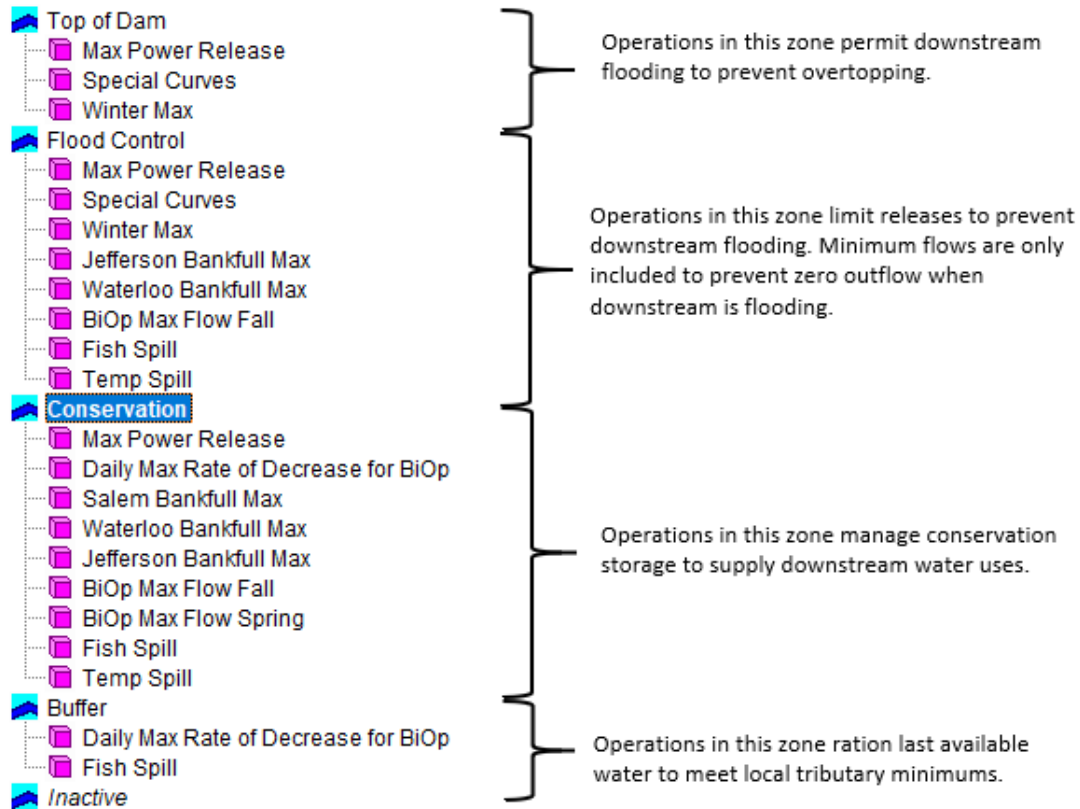
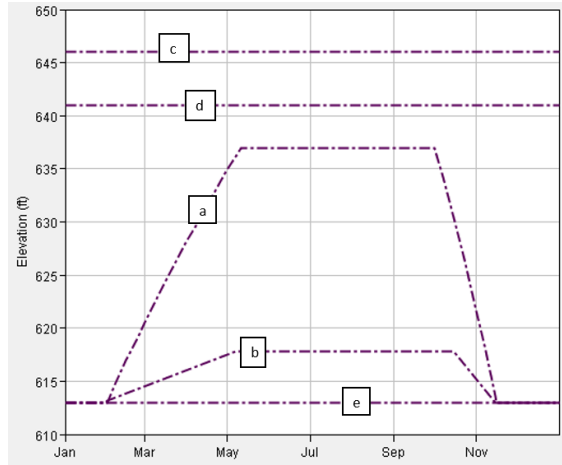

Figure 3-49. Foster Dam and Reservoir Operational Summary.

3.5.10.2 Foster Dam and Reservoir HEC-ResSim Water Control Diagram

A water control diagram including all zones in HEC-ResSim for Foster Dam and Reservoir is provided in Figure 3-50. A table detailing seasonal zone elevations is provided in Table 3-22. All zones are defined in the project’s water control manual except for the buffer zone. The buffer zone is for modeling purposes intended to estimate likely conservation actions taken by regulators in extremely low storage situations when local tributary flows would be prioritized above withdrawals and mainstem flow targets.

*Willamette Valley System Operations and Maintenance
Environmental Impact Statement*



**Figure 3-50. Foster Dam and Reservoir HEC-ResSim
Water Control Diagram.**

Table 3-22. Foster Reservoir Zone Elevations.

Conservation Zone (a)	Elevation, feet
1-Jan	613.0
7-Jan	613.0
15-Jan	613.0
23-Jan	613.0
1-Feb	613.0
7-Feb	614.7
15-Feb	616.9
23-Feb	619.0
1-Mar	620.6
7-Mar	622.1
15-Mar	624.1
23-Mar	626.0
1-Apr	628.2
7-Apr	629.5
15-Apr	631.4
23-Apr	633.2
1-May	634.9
7-May	636.2
11-May	637.0
1-Oct	637.0
7-Oct	634.2
15-Oct	630.4
23-Oct	626.4
1-Nov	621.7
7-Nov	618.3
15-Nov	613.6

*Willamette Valley System Operations and Maintenance
Environmental Impact Statement*

Conservation Zone (a)	Elevation, feet
16-Nov	613.0
1-Dec	613.0
Buffer Zone (b)	Elevation, feet
1-Jan	613.0
31-Jan	613.0
1-Feb	613.2
7-May	617.8
20-May	617.8
15-Oct	617.8
15-Nov	613.0
31-Dec	613.0
Top of Dam Zone (c)	Elevation, feet
All Year	646
Flood Control Zone (d)	Elevation, feet
All Year	641
Inactive Zone (e)	Elevation, feet
All Year	613

3.5.10.3 Foster Dam and Reservoir Detailed Operational Descriptions

A description of each operation at Foster Dam and Reservoir is provided below followed by detailed screenshots of each operation in Figure 3-51 and Figure 3-52.

- *Maximum Power Release* - maximum flow through powerhouse.
- *Special Curves* - induced surcharge function, a function of elevation and inflow. Designed for flood events that present risk of dam overtopping.
- *Winter Maximum* - Maximum release as a function of pool elevation. Designed to mimic flood season maximum releases.
- ***** minimum outflow downstream of FOS defined at Green Peter *****
- *Fish Spill* – Releases half of flow (all flow for half of day) over spillway for downstream fish passage except when outflow is less than station service (150 cfs).
- *Temp Spill* – Flow released through new outlet (modeled over spillway) to manage temperature.
- *Jefferson Bankfull Maximum* - Bankfull at Jefferson is 43,000 cfs.
- *Waterloo Bankfull Maximum* - Bankfull at Waterloo is 19,000 cfs.
- *BiOp Maximum Flow Fall* - Maximum fall spawning flow is 3,000 cfs.
- *Daily Maximum Rate of Decrease for BiOp* - Defines the next day’s minimum outflow as a function of current outflow. Designed to result in the lesser of 1 foot per day tailwater change or a 50 percent reduction in flow per the NMFS 2008 BiOp.

*Willamette Valley System Operations and Maintenance
Environmental Impact Statement*

- *Salem Bankfull Maximum* - Salem Bankfull is 94,000 cfs.
- *BiOp Maximum Flow Spring* - Maximum flow in spring is 3,000 cfs.
- *BiOp Maximum Fos* – NMFS 2008 BiOp minimum release.

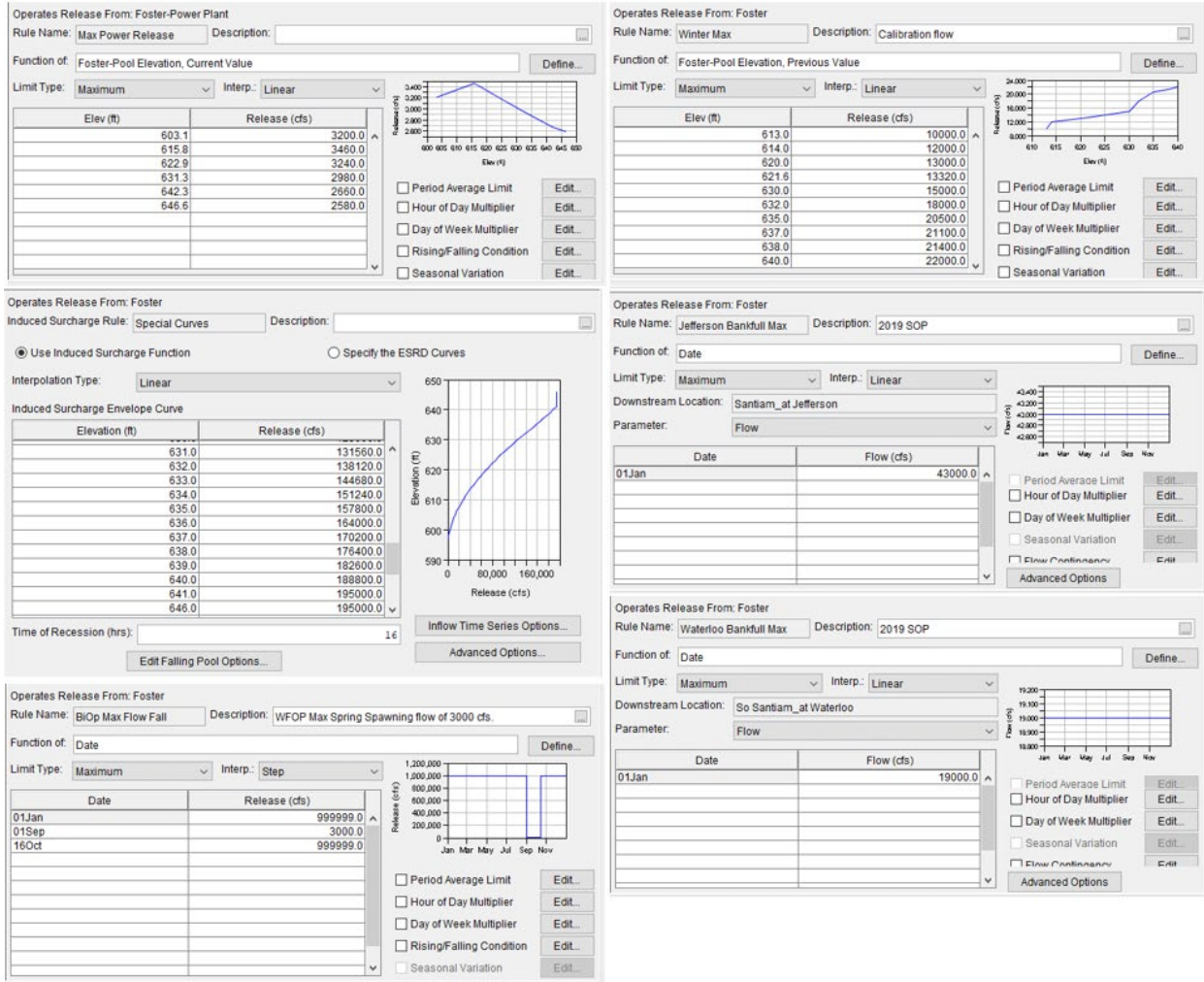

Figure 3-51. Foster Dam and Reservoir NAA Operation Set Rules.

*Willamette Valley System Operations and Maintenance
Environmental Impact Statement*

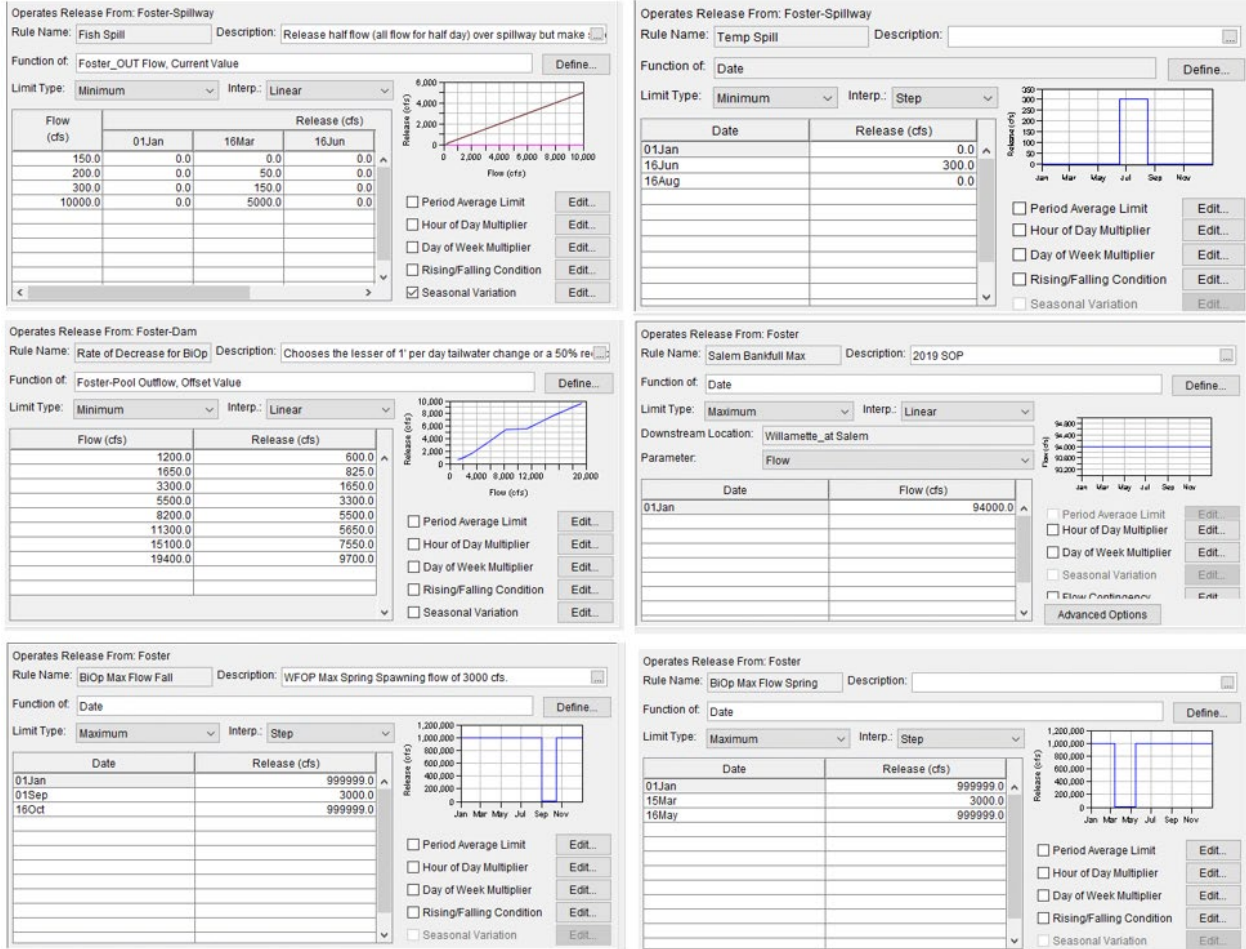

Figure 3-52. Foster Dam and Reservoir NAA Operation Set Rules, Continued.

3.5.11 Detroit Dam and Reservoir Modeled Operations

3.5.11.1 Detroit Dam and Reservoir Operational Summary

A summary of reservoir zones, operations defined for each zone, and each zone’s role in reservoir regulation is identified in Figure 3-53. Operations only apply to the zone where they are located. The higher the location of an operation in a zone the higher the priority of that operation.

*Willamette Valley System Operations and Maintenance
Environmental Impact Statement*

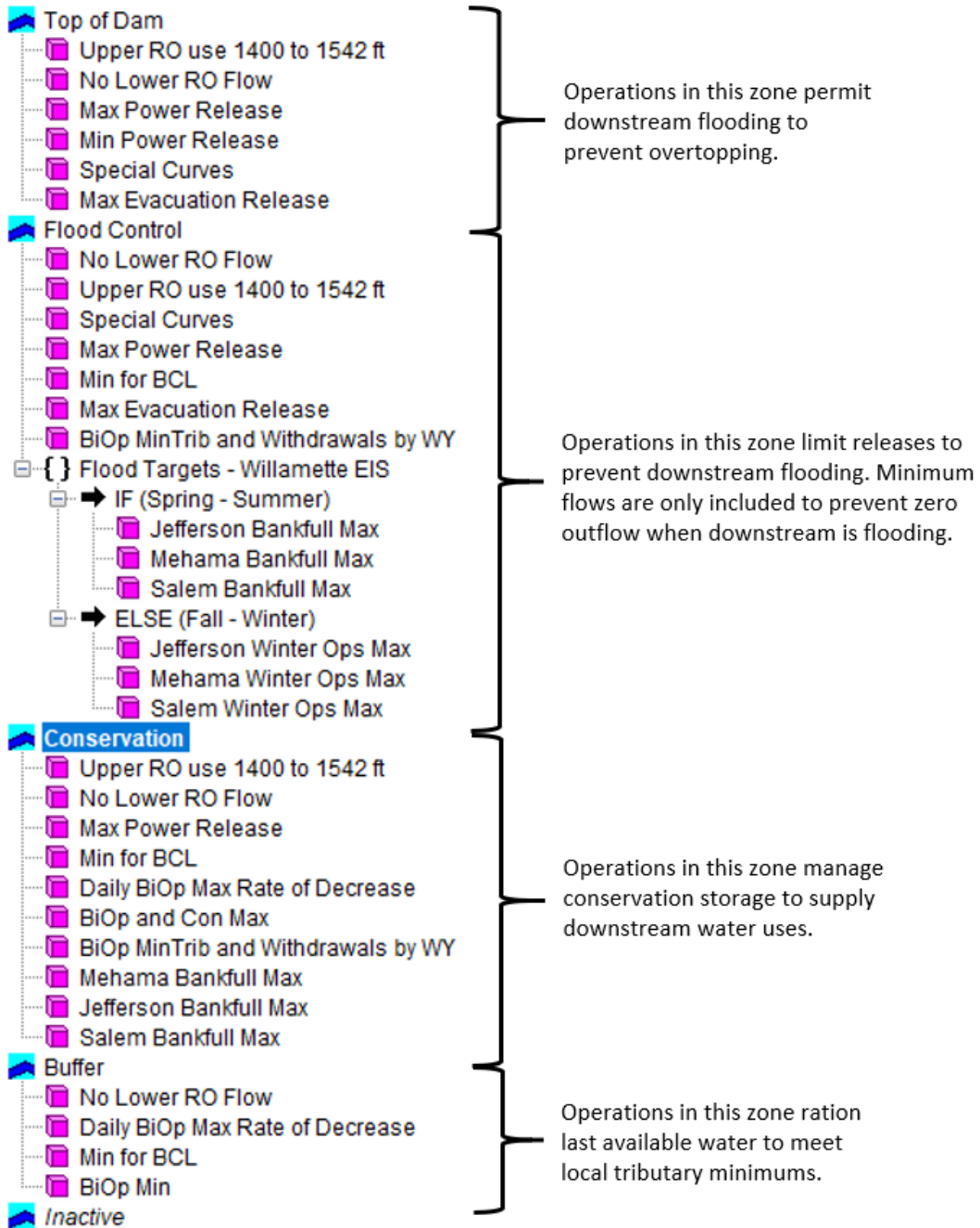

Figure 3-53. Detroit Dam and Reservoir Operational Summary.

3.5.11.2 Detroit Dam and Reservoir HEC-ResSim Water Control Diagram

A water control diagram, including all zones in HEC-ResSim, for Detroit Dam and Reservoir is provided in Figure 3-54. A table detailing seasonal zone elevations is provided in Table 3-23. Detroit Dam and Reservoir currently (August 2020) has an Interim Risk Reduction Measure (IRRM) pool restriction, but this pool restriction is not in the NAA because it is interim. All zones are defined in the project’s water control manual except for the buffer zone. The buffer zone is for modeling purposes intended to estimate likely conservation actions taken by regulators in

*Willamette Valley System Operations and Maintenance
Environmental Impact Statement*

extremely low storage situations when local tributary flows would be prioritized above withdrawals and mainstem flow targets.

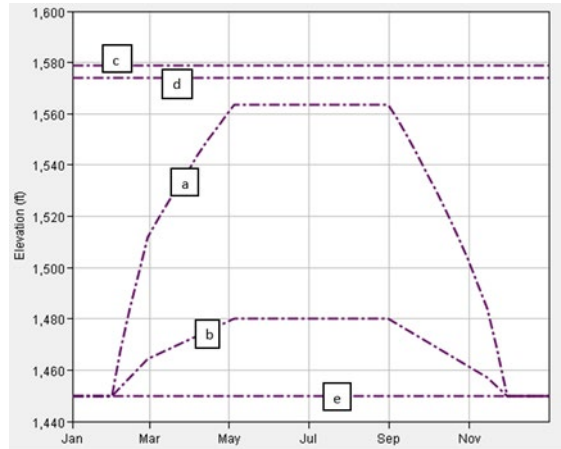

Figure 3-54. Detroit Dam and Reservoir HEC-ResSim Water Control Diagram.

Table 3-23. Detroit Reservoir Zone Elevations.

Conservation Zone (a)	Elevation, feet
1-Jan	1,450.0
31-Jan	1,450.0
7-Feb	1,467.7
14-Feb	1,484.0
21-Feb	1,498.7
28-Feb	1,512.1
7-Mar	1,518.4
15-Mar	1,525.3
23-Mar	1,531.9
31-Mar	1,538.3
7-Apr	1,543.8
15-Apr	1,549.7
22-Apr	1,554.7
30-Apr	1,560.2
5-May	1,563.5
31-Aug	1,563.5
7-Sep	1,557.7
15-Sep	1,550.7
22-Sep	1,544.4
30-Sep	1,536.7
7-Oct	1,529.6
15-Oct	1,521.3
23-Oct	1,512.5

*Willamette Valley System Operations and Maintenance
Environmental Impact Statement*

Conservation Zone (a)	Elevation, feet
31-Oct	1,503.2
7-Nov	1,494.6
15-Nov	1,484.1
22-Nov	1,468.9
30-Nov	1,450.0
31-Dec	1,450.0
Buffer Zone (b)	Elevation, feet
1-Jan	1,450.00
31-Jan	1,450.00
28-Feb	1,464.38
5-May	1,479.98
31-Aug	1,479.98
15-Nov	1,457.17
30-Nov	1,450.00
31-Dec	1,450.00
Top of dam Zone (c)	Elevation, feet
All Year	1,579
Flood Control Zone (d)	Elevation, feet
All Year	1,574
Inactive Zone (e)	Elevation, feet
All Year	1,450

3.5.11.3 Detroit Dam and Reservoir Detailed Operational Descriptions

A description of each operation at Detroit Dam and Reservoir is provided below followed by detailed screenshots of each operation in Figure 3-55, Figure 3-56, and Figure 3-57.

- *Upper regulating outlet use 1,400 to 1,542 feet* - Only use upper regulating outlet when above 1,400 feet and below 1,542 feet.
- *No Lower regulating outlet Flow* - Do not use lower regulating outlet.
- *Maximum Power Release* - Maximum flow through powerhouse.
- *Minimum Power Release* - Minimum flow through powerhouse to prevent cavitation at Big Cliff Dam (different than speed no load).
- *Special Curves* - induced surcharge function, a function of elevation and inflow. Designed for flood events that present risk of dam overtopping.
- *Maximum Evacuation Release* - Maximum release as a function of pool elevation. Designed to mimic flood season maximum releases.
- *BiOp MinTrib and Withdrawals by WY* – Includes minimum flows to satisfy the NMFS 2008 BiOp and 2050 projected consumptive withdrawals.

*Willamette Valley System Operations and Maintenance
Environmental Impact Statement*

- *Flood Targets IF Block* - Divides flood reduction operations into spring and winter.
- *Jefferson Bankfull Maximum* - Jefferson Bankfull is 43,000 cfs.
- *Mehama Bankfull Maximum* - Mehama Bankfull is 17,000 cfs.
- *Salem Bankfull Maximum* - Salem Bankfull is 94,000 cfs.
- *Jefferson Winter Ops Maximum* - Downstream flood reduction depending on reservoir elevation.
- *Mehama Winter Ops Maximum* - Downstream flood reduction depending on reservoir elevation.
- *Salem Winter Ops Maximum* - Downstream flood reduction depending on reservoir elevation.
- *Daily BiOp Maximum Rate of Decrease* - Defines the next day's minimum outflow as a function of current outflow. Designed to result in the lesser of 1 foot per day tailwater change or a 50 percent reduction in flow per the NMFS 2008 BiOp.
- *BiOp and Con Max* - BiOp maximum applied all conservation season to match typically maximum summer flows.
- *BiOp Minimum* – NMFS 2008 BiOp minimum release.
- *A temperature spill operation is post-processed outside of HEC-ResSim into the Detroit Dam and Reservoir results. The temperature spill operation releases 60 percent of the total outflow over the spillway 15Jun–15Nov when reservoir elevations are above the spillway, and 60 percent of the total outflow through the regulating outlet 01Oct–15Nov when elevations are below the spillway.

*Willamette Valley System Operations and Maintenance
Environmental Impact Statement*

Operates Release From: Detroit-Upper Controlled Outlet
 Rule Name: *per RO use 1400 to 1542 ft* Description:
 Function of: *Detroit-Pool Elevation, Current Value*
 Limit Type: *Maximum* Interp: *Step*

Elev (ft)	Release (cfs)
1399.9	0.0
1400.0	12140.0
1420.0	12140.0
1542.0	12140.0
1542.1	0.0

 Period Average Limit Hour of Day Multiplier Day of Week Multiplier Rising/Falling Condition Seasonal Variation

Operates Release From: Detroit-Lower Controlled Outlet
 Rule Name: *No Lower RO Flow* Description: *The lower RO has physical properties listed, but there should be n...*
 Function of: *Date*
 Limit Type: *Maximum* Interp: *Step*

Date	Release (cfs)
01-Jan	0.0

 Period Average Limit Hour of Day Multiplier Day of Week Multiplier Rising/Falling Condition Seasonal Variation

Operates Release From: Detroit-Power Plant
 Rule Name: *Max Power Release* Description:
 Function of: *Detroit-Pool Elevation, Current Value*
 Limit Type: *Maximum* Interp: *Linear*

Elev (ft)	Release (cfs)
1427.0	4050.0
1452.0	4900.0
1485.0	5850.0
1492.0	5550.0
1512.0	5050.0
1542.0	4550.0
1582.0	4200.0

 Period Average Limit Hour of Day Multiplier Day of Week Multiplier Rising/Falling Condition Seasonal Variation

Operates Release From: Detroit-Power Plant
 Rule Name: *Min Power Release* Description: *To prevent cavitation (rule added August 2020)*
 Function of: *Date*
 Limit Type: *Minimum* Interp: *Linear*

Date	Release (cfs)
01-Jan	1050.0

 Period Average Limit Hour of Day Multiplier Day of Week Multiplier Rising/Falling Condition Seasonal Variation

Operates Release From: Detroit
 Induced Surcharge Rule: *Special Curves* Description:
 Use Induced Surcharge Function Specify the ESRD Curves
 Interpolation Type: *Linear*
 Induced Surcharge Envelope Curve

Elevation (ft)	Release (cfs)
1541.0	0.0
1543.0	2520.0
1544.0	4320.0
1545.0	6480.0
1546.0	9000.0
1547.0	11880.0
1548.0	15120.0
1549.0	18720.0
1550.0	22680.0
1551.0	27120.0
1552.0	31920.0
1553.0	37020.0
1554.0	42420.0
1555.0	48060.0
1556.0	53880.0
1557.0	59820.0
1558.0	65820.0
1559.0	71940.0
1560.0	78240.0
1561.0	84780.0
1562.0	91560.0
1563.0	98580.0
1564.0	105840.0
1565.0	113340.0
1566.0	121080.0
1567.0	129060.0
1568.0	137280.0
1569.0	145740.0
1570.0	154440.0
1571.0	163380.0
1572.0	172560.0
1573.0	181980.0
1574.0	191640.0

 Time of Recession (hrs): *23.3*

Operates Release From: Detroit-Dam
 Rule Name: *Max Evacuation Release* Description: *Calibration*
 Function of: *Detroit-Pool Elevation, Previous Value*
 Limit Type: *Maximum* Interp: *Linear*

Elev (ft)	Release (cfs)
1450.0	5000.0
1465.0	5000.0
1500.0	10000.0
1545.0	15000.0
1563.0	17000.0

 Period Average Limit Hour of Day Multiplier Day of Week Multiplier Rising/Falling Condition Seasonal Variation

Operates Release From: Detroit
 Rule Name: *Min for BCL* Description:
 Function of: *Date*
 Limit Type: *Minimum* Interp: *Linear*

Date	Release (cfs)
01-Jan	1050.0

 Period Average Limit Hour of Day Multiplier Day of Week Multiplier Rising/Falling Condition Seasonal Variation

Figure 3-55. Detroit Dam and Reservoir NAA Operation Set Rules.

*Willamette Valley System Operations and Maintenance
Environmental Impact Statement*

Operates Release From: Detroit-Dam

Rule Name: **tb and Withdrawals by WY** Description: []

Function of: **Water Year Type, Current Value**

Limit Type: **Minimum** Interp.: **Linear**

Water Year Type	01Jan	01Feb	01Mar	15Mar	01Apr	01May	01Jun	01Jul	15Jul	01Aug	01Sep	01Oct	16Oct	01Nov	01Dec
0.0	1200.0	1000.0	1000.0	1500.0	1500.0	1500.0	1226.0	1234.0	1034.0	1035.0	1529.0	1500.0	1200.0	1200.0	1200.0
0.9	1200.0	1000.0	1000.0	1500.0	1500.0	1500.0	1232.0	1242.0	1042.0	1043.0	1535.0	1500.0	1200.0	1200.0	1200.0
1.2	1200.0	1000.0	1000.0	1500.0	1500.0	1500.0	1240.0	1252.0	1052.0	1053.0	1543.0	1500.0	1200.0	1200.0	1200.0
1.48	1200.0	1000.0	1000.0	1500.0	1500.0	1500.0	1246.0	1260.0	1060.0	1062.0	1550.0	1500.0	1200.0	1200.0	1200.0
2.0	1200.0	1000.0	1000.0	1500.0	1500.0	1500.0	1246.0	1260.0	1060.0	1062.0	1550.0	1500.0	1200.0	1200.0	1200.0

Operates Release From: Detroit

Rule Name: **Jefferson Bankfull Max** Description: **2019 SOP**

Function of: **Date**

Limit Type: **Maximum** Interp.: **Linear**

Downstream Location: **Santiam_at Jefferson**

Parameter: **Flow**

Date	Flow (cfs)
01Jan	43000.0

Operates Release From: Detroit

Rule Name: **Jefferson Winter Ops Max** Description: **2019 SOP Bankfull 43,000 flood 55,900**

Function of: **Detroit-Pool Elevation, Current Value**

Limit Type: **Maximum** Interp.: **Linear**

Downstream Location: **Santiam_at Jefferson**

Parameter: **Flow**

Elev (ft)	Flow (cfs)
1424.0	43000.0
1536.0	43000.0
1546.0	55900.0
1574.0	55900.0

Operates Release From: Detroit

Rule Name: **Mehama Bankfull Max** Description: **2019 SOP**

Function of: **Date**

Limit Type: **Maximum** Interp.: **Linear**

Downstream Location: **No Santiam_at Mehama**

Parameter: **Flow**

Date	Flow (cfs)
01Jan	17000.0

Operates Release From: Detroit

Rule Name: **Mehama Winter Ops Max** Description: []

Function of: **Detroit-Pool Elevation, Current Value**

Limit Type: **Maximum** Interp.: **Linear**

Downstream Location: **No Santiam_at Mehama**

Parameter: **Flow**

Elev (ft)	Flow (cfs)
1424.0	17000.0
1536.0	17000.0
1546.0	30500.0
1574.0	30500.0

Operates Release From: Detroit

Rule Name: **Salem Bankfull Max** Description: **2019 SOP**

Function of: **Date**

Limit Type: **Maximum** Interp.: **Linear**

Downstream Location: **Willamette_at Salem**

Parameter: **Flow**

Date	Flow (cfs)
01Jan	94000.0

Operates Release From: Detroit

Rule Name: **Salem Winter Ops Max** Description: []

Function of: **Detroit-Pool Elevation, Current Value**

Limit Type: **Maximum** Interp.: **Linear**

Downstream Location: **Willamette_at Salem**

Parameter: **Flow**

Elev (ft)	Flow (cfs)
1424.0	94000.0
1536.0	94000.0
1546.0	154300.0
1574.0	154300.0

Figure 3-56. Detroit Dam and Reservoir NAA Operation Set Rules, Continued.

*Willamette Valley System Operations and Maintenance
Environmental Impact Statement*

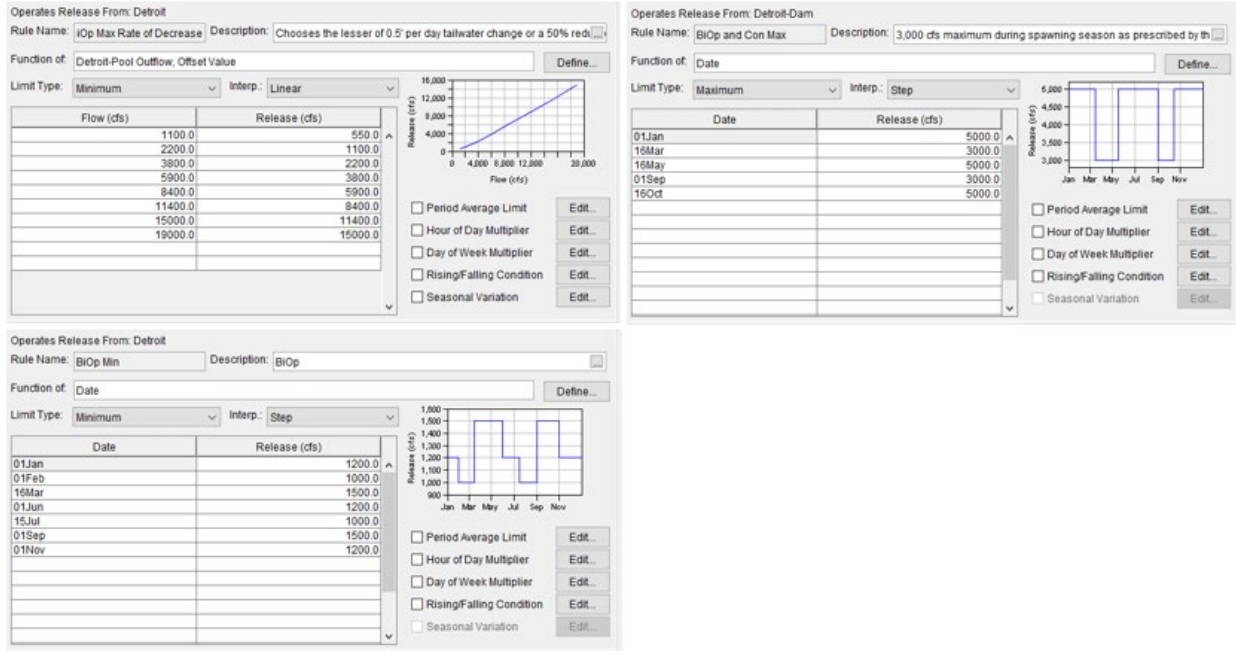

Figure 3-57. Detroit Dam and Reservoir NAA Operation Set Rules, Continued.

3.6 HEC-ResSim NAA Simulation Results

The HEC-ResSim results for the NAA Simulation are in a HEC-DSS file from the program that is labeled by default “simulation.dss”. Each time series record contains daily data for the duration of the simulation, which was 01 October 1935 through 30 September 2019. The program evaluates every computation point, river reach, and every dam outlet and parameter for each of the daily time steps in the simulation.

The NAA simulation was verified to be a realistic representation of current conservation season operations based a visual comparison of modeled and observed reservoir elevations and control point flows between 2008 and 2019, which represents the period of record for post 2008 Biological Opinion (NMFS 2008) implementation operations. Adaptive management and maintenance operations are not modeled. The model used is not intended to model winter operations with high precision. Figure 3-58 through Figure 3-68 show the comparison plots of reservoir elevations used to validate the model. Figure 3-69 and Figure 3-70 show comparison plots for the mainstem Willamette River control points.

Willamette Valley System Operations and Maintenance
Environmental Impact Statement

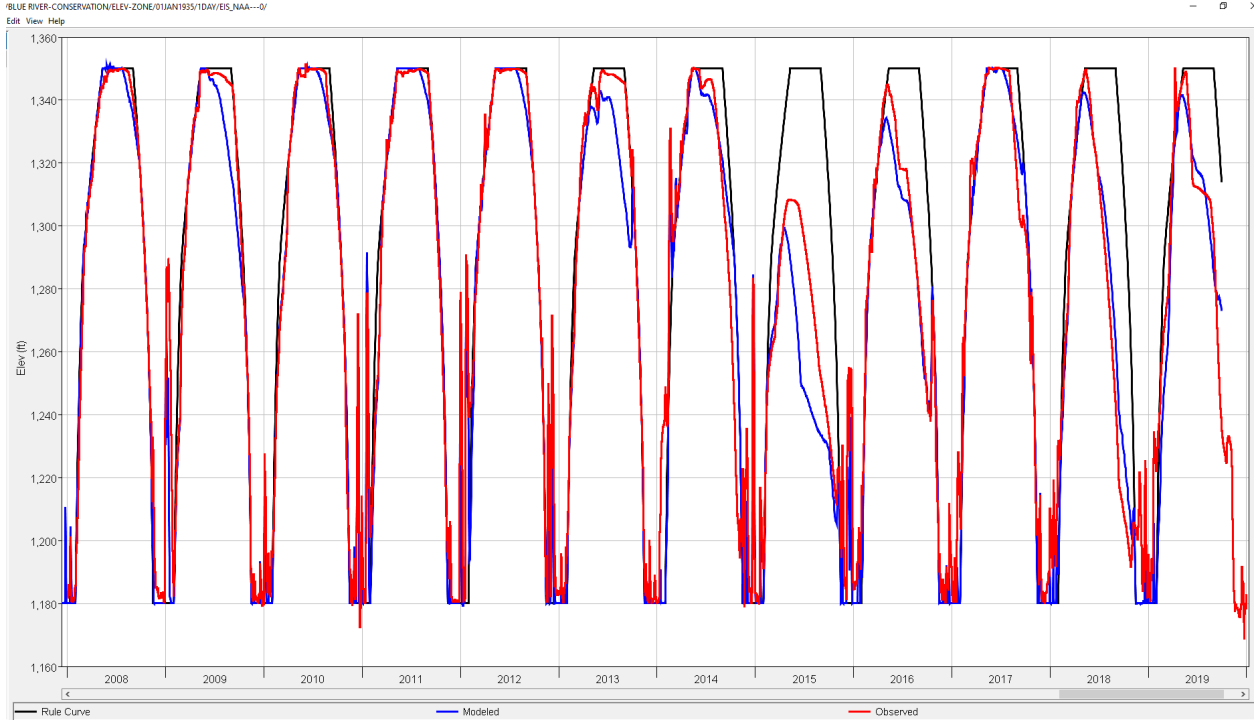

Figure 3-58. Blue River Dam and Reservoir Validation.

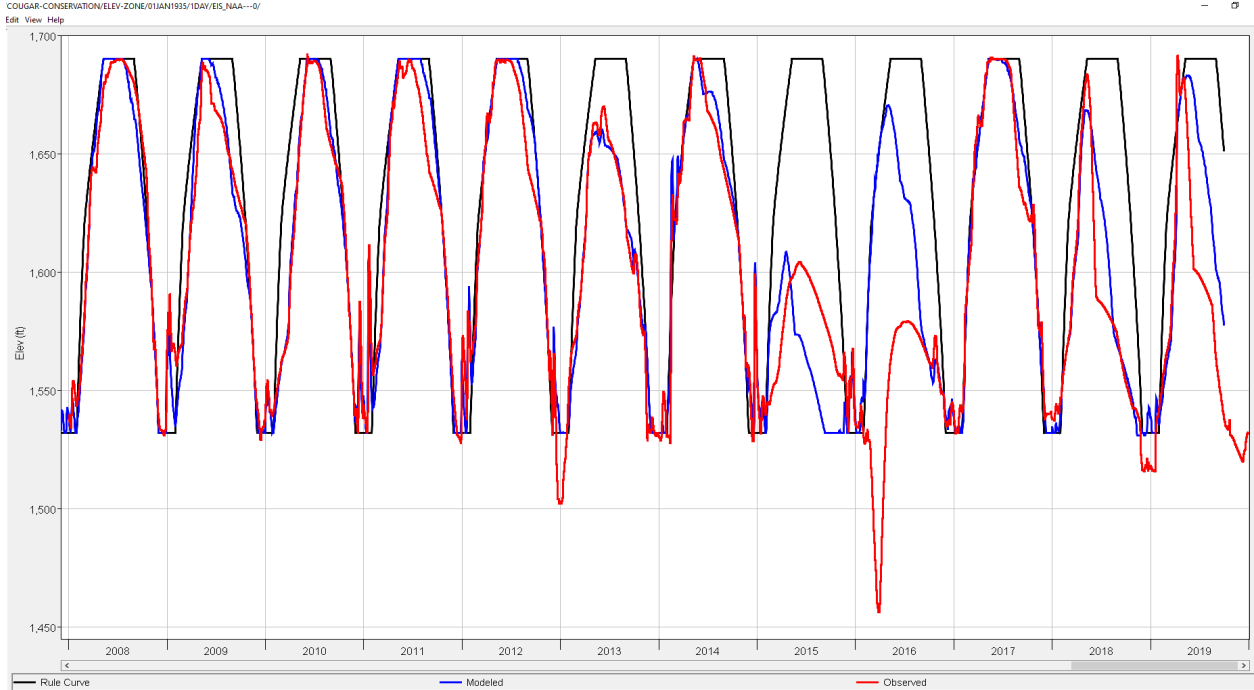

Figure 3-59. Cougar Dam and Reservoir Model Validation.

Willamette Valley System Operations and Maintenance
Environmental Impact Statement

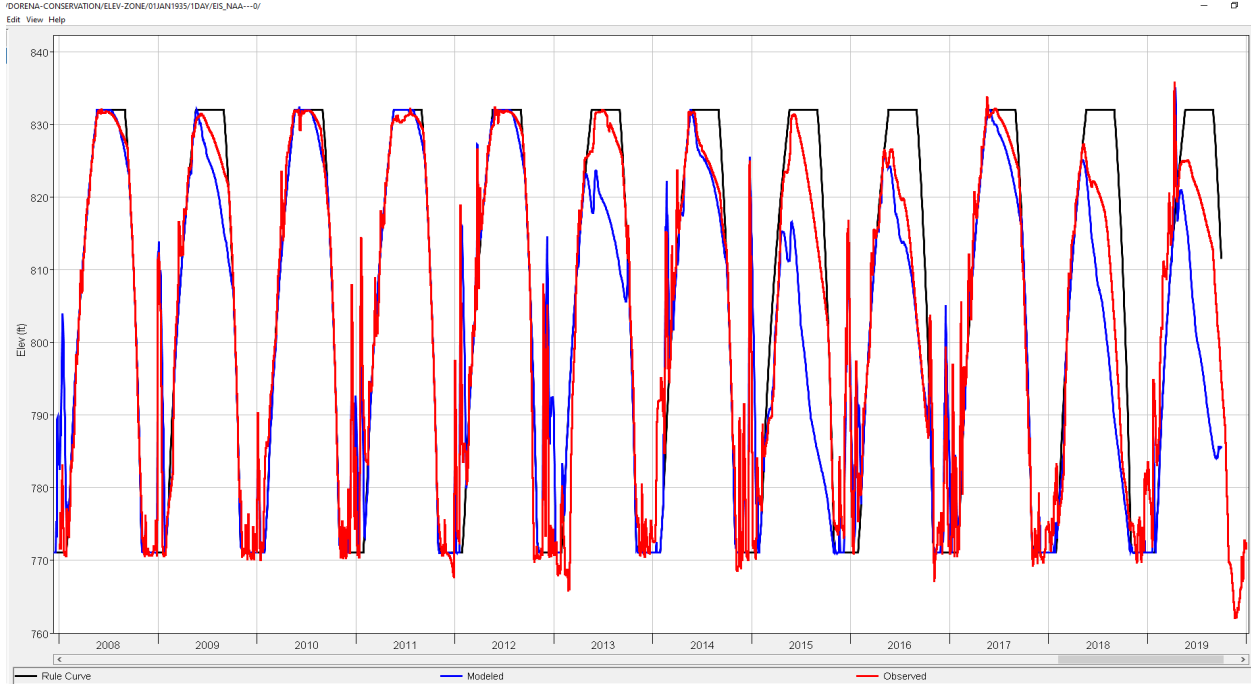

Figure 3-60. Dorena Dam and Reservoir Model Validation.

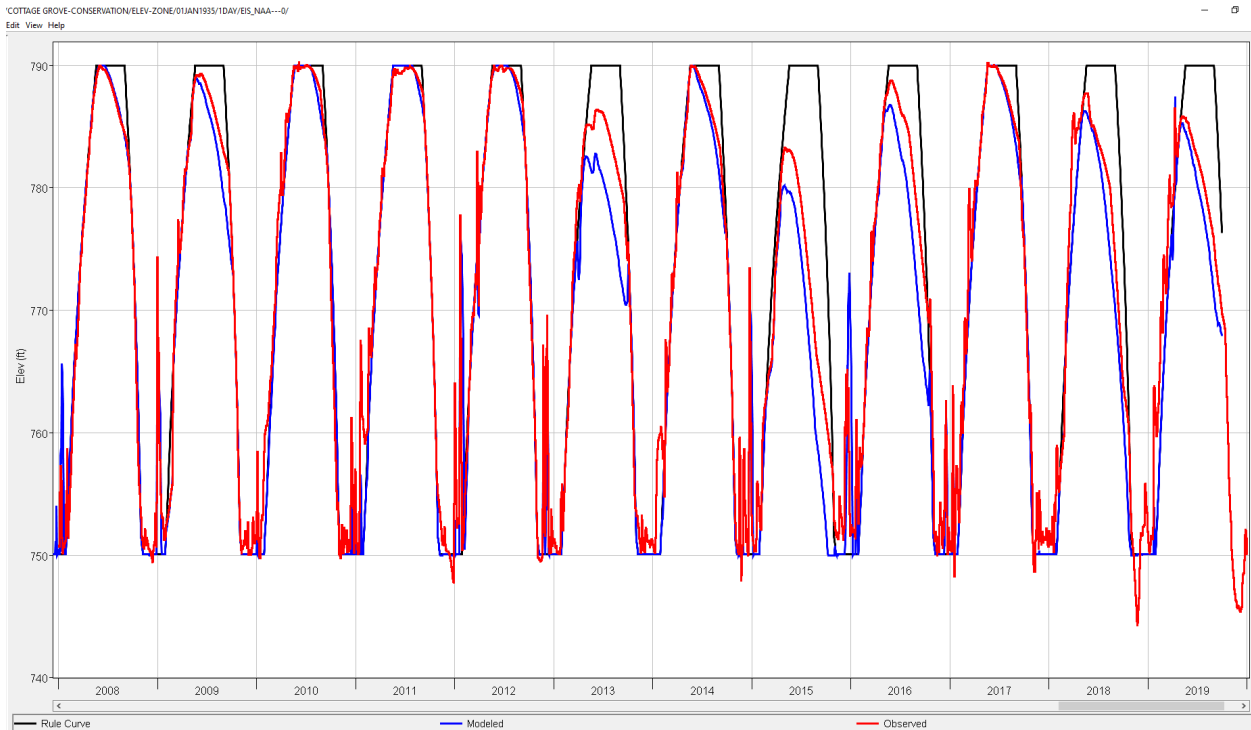

Figure 3-61. Cottage Grove Dam and Reservoir Model Validation.

Willamette Valley System Operations and Maintenance
Environmental Impact Statement

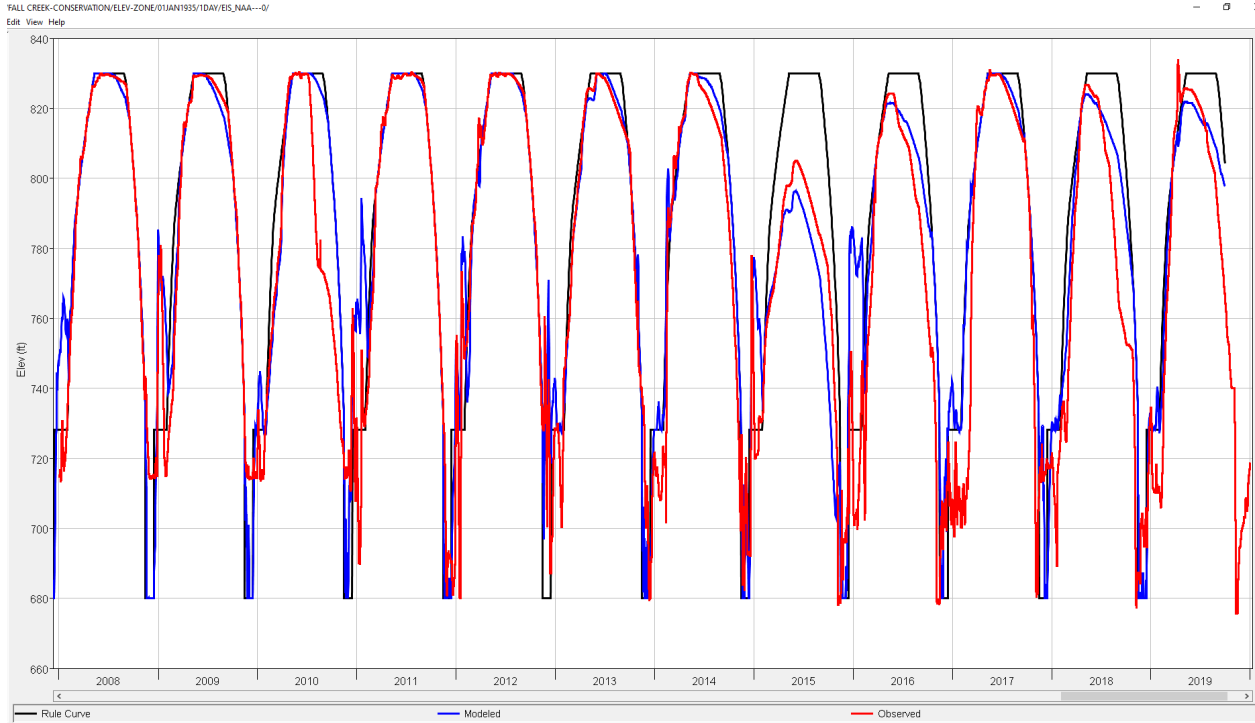

Figure 3-62. Fall Creek Dam and Reservoir Model Validation.

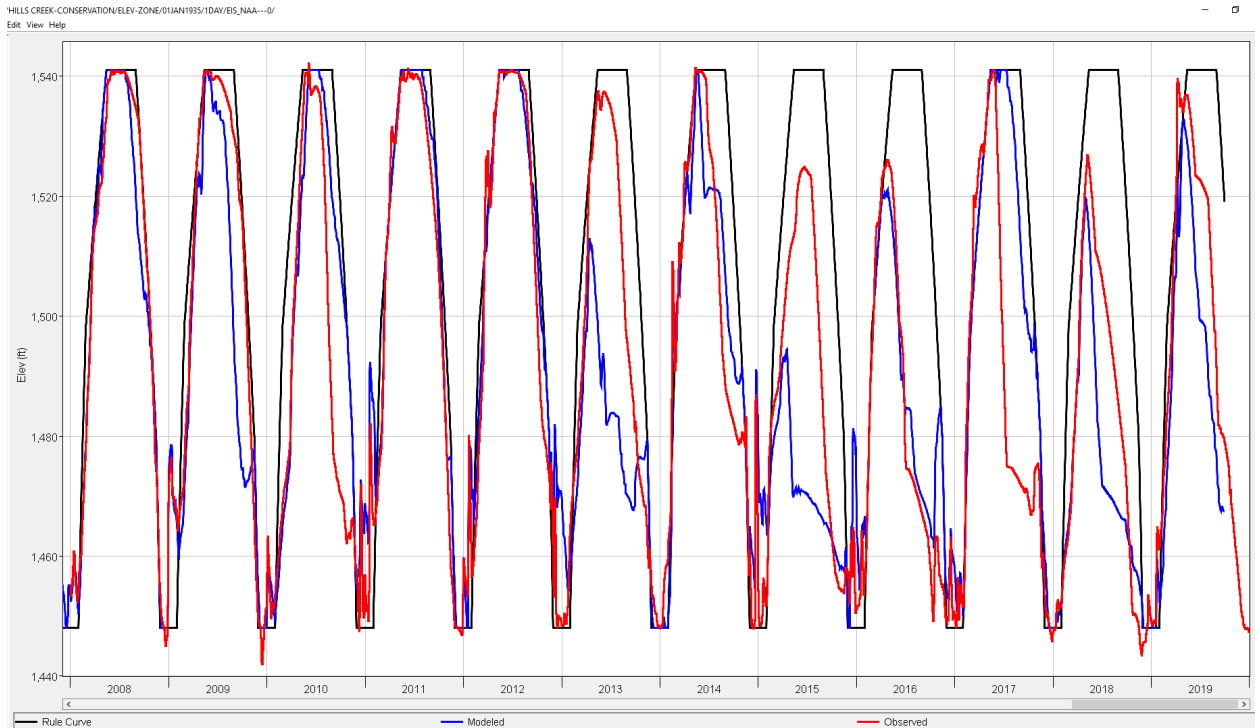

Figure 3-63. Hills Creek Dam and Reservoir Model Validation.

Willamette Valley System Operations and Maintenance
Environmental Impact Statement

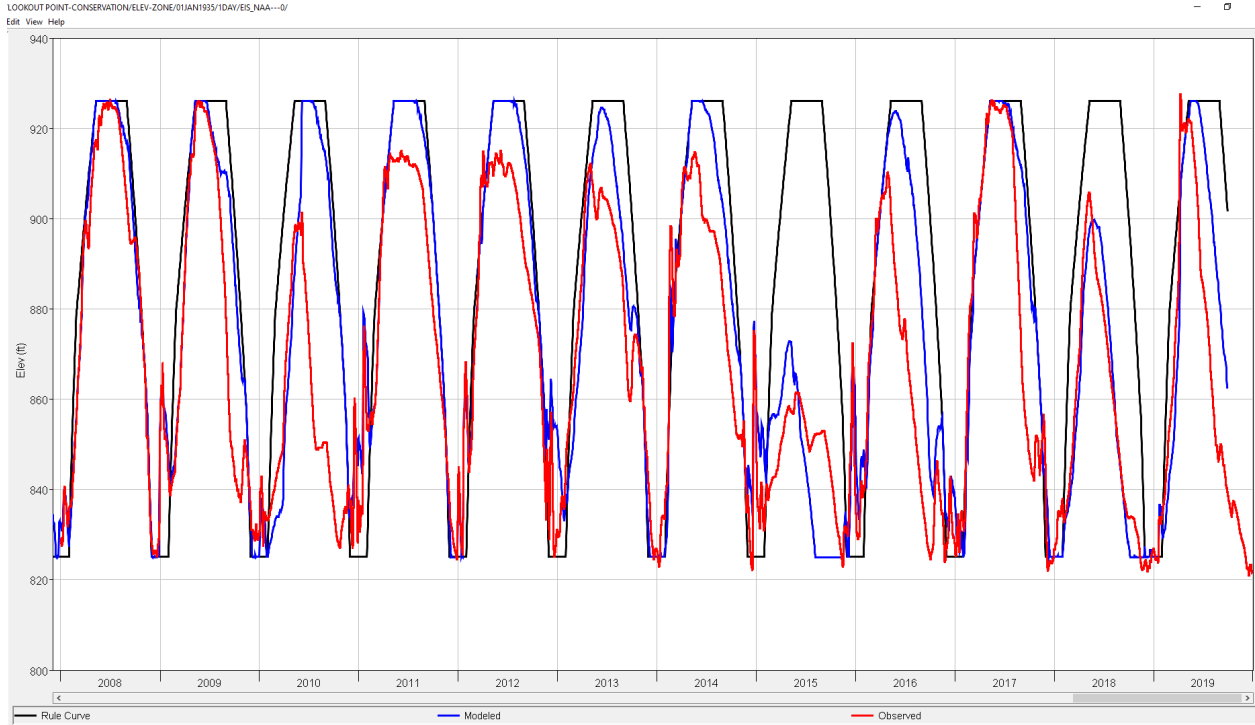

Figure 3-64. Lookout Point Dam and Reservoir Model Validation.

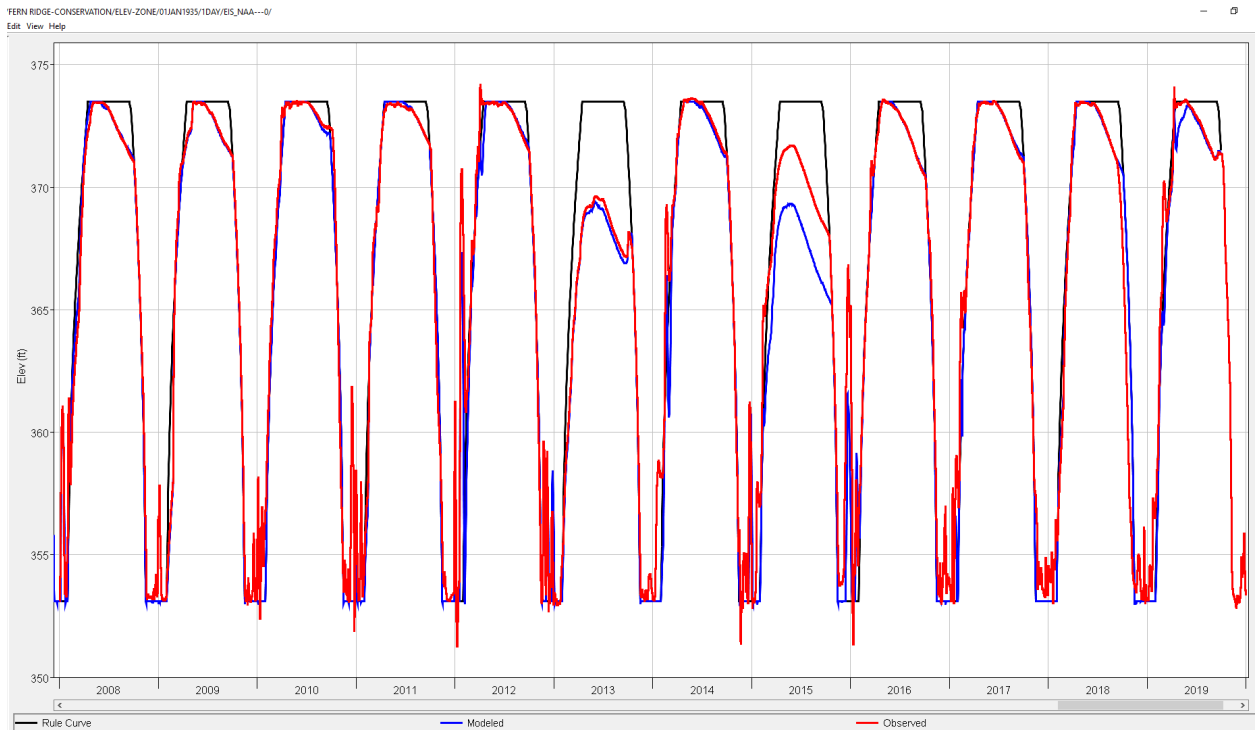

Figure 3-65. Fern Ridge Dam and Reservoir Model Validation.

Willamette Valley System Operations and Maintenance
Environmental Impact Statement

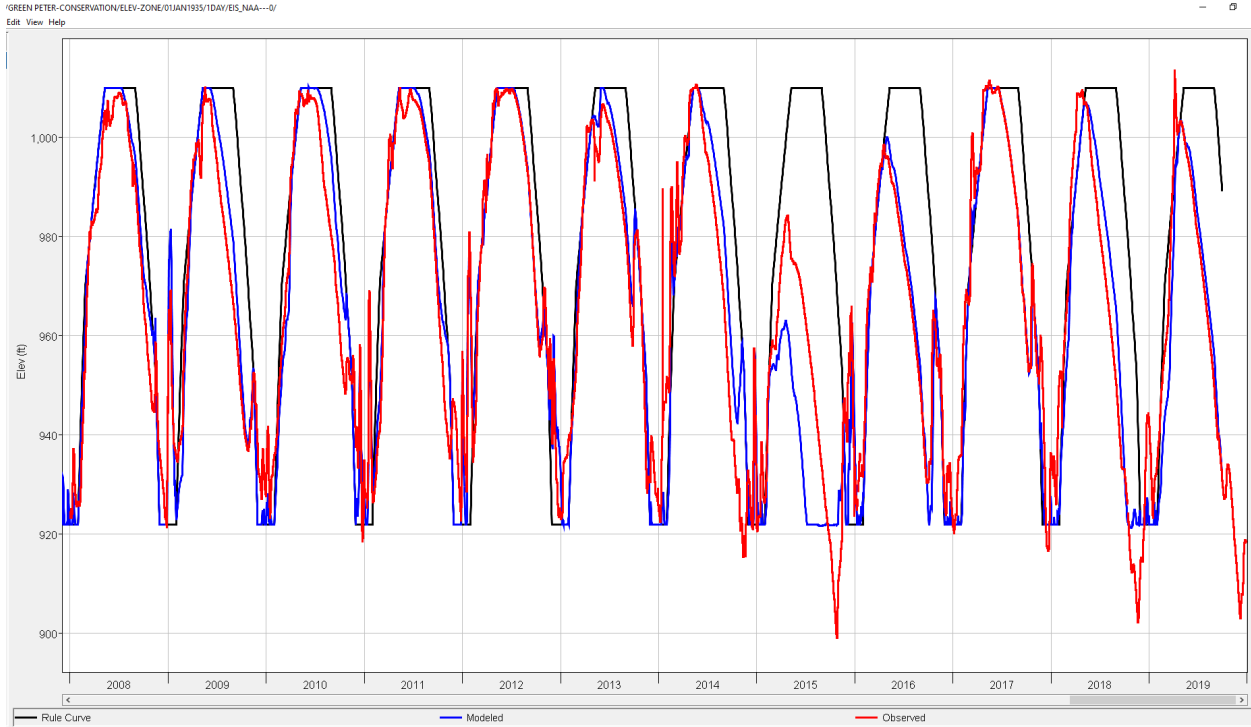

Figure 3-66. Green Peter Dam and Reservoir Model Validation.

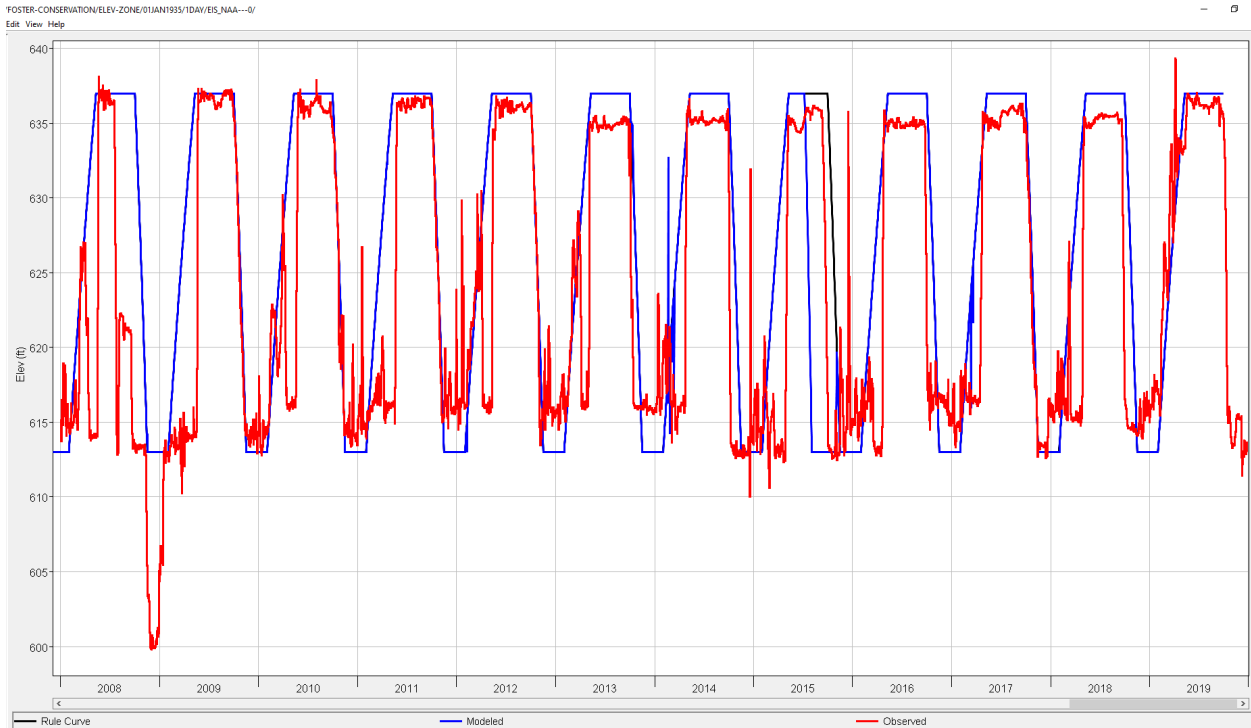

Figure 3-67. Foster Dam and Reservoir Model Validation.

Willamette Valley System Operations and Maintenance
Environmental Impact Statement

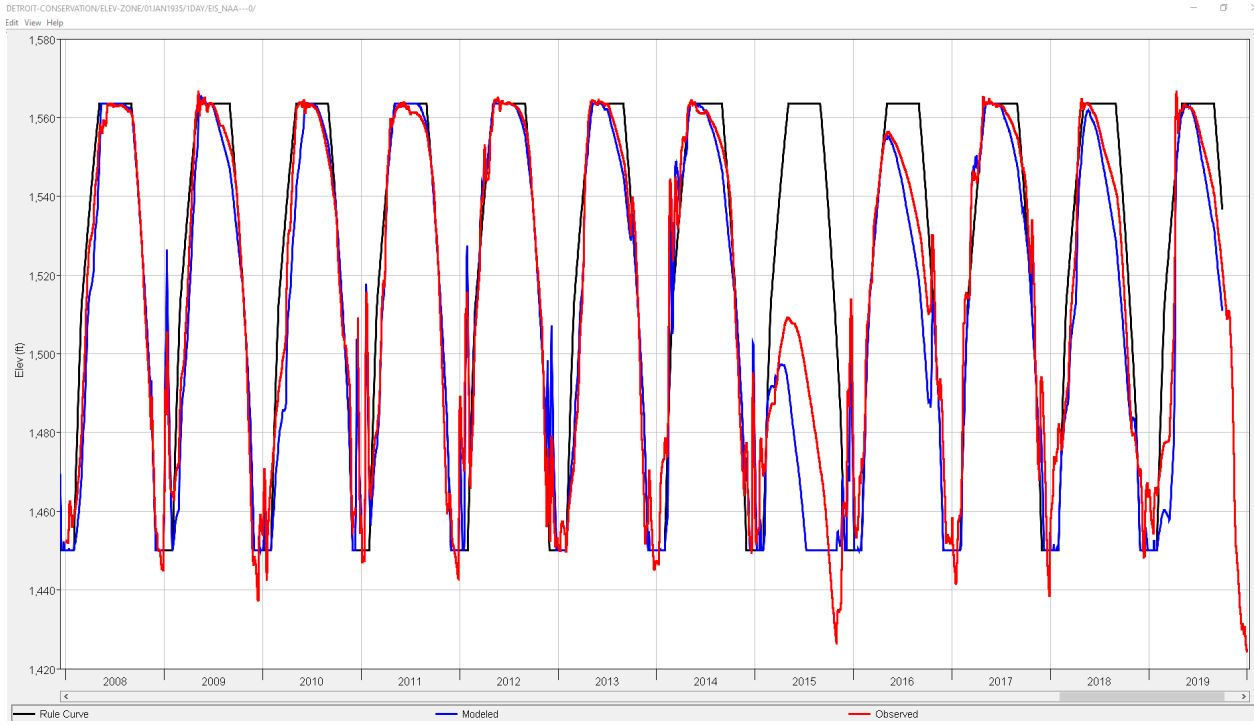

Figure 3-68. Detroit Dam and Reservoir Model Validation.

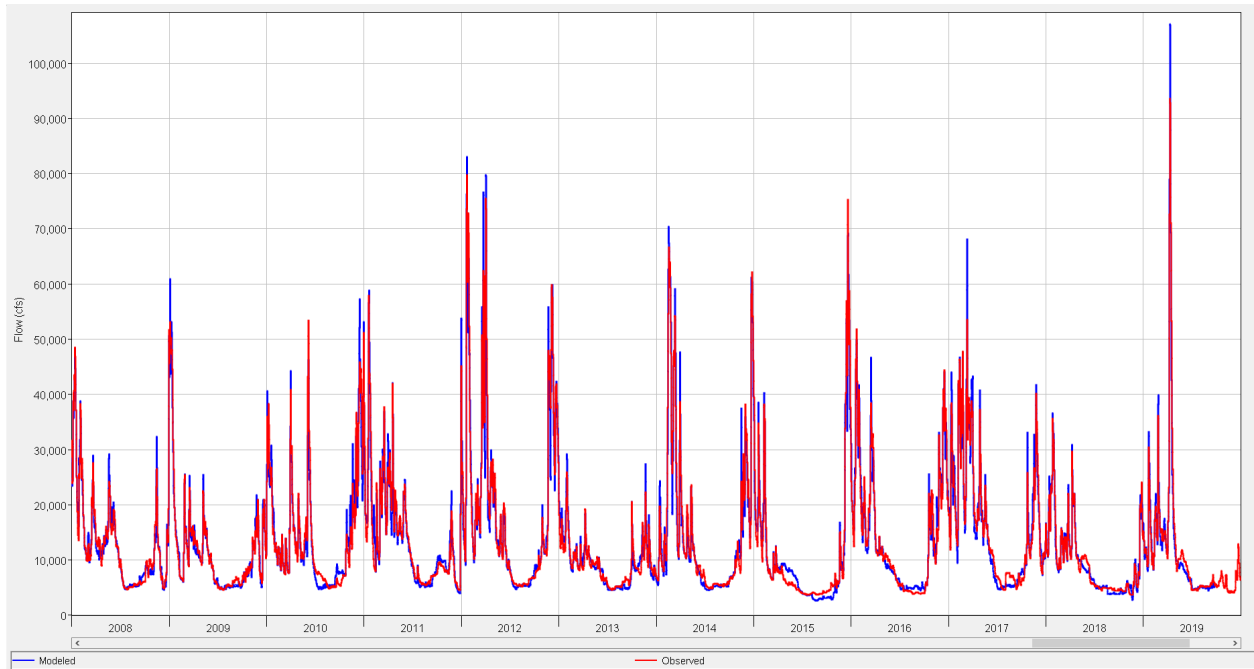

Figure 3-69. Willamette at Albany Model Validation.

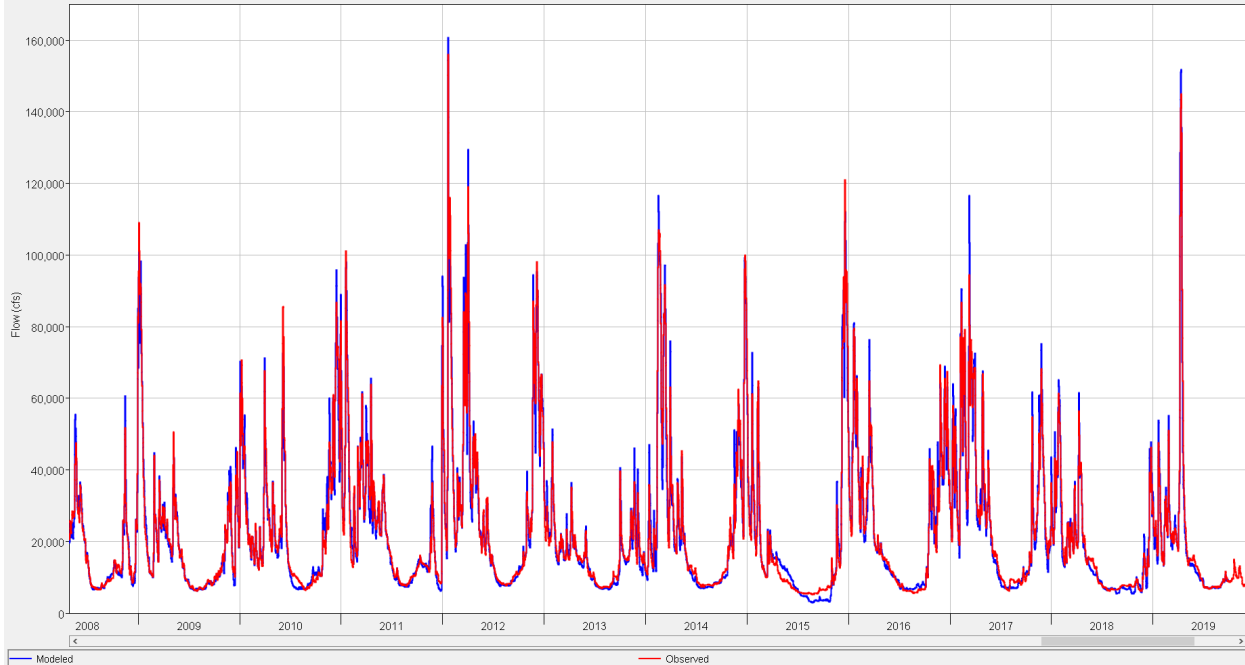

Figure 3-70. Willamette at Salem Model Validation

4 ALTERNATIVE MODELING ASSUMPTIONS

Each alternative is modeled in HEC-ResSim by modifying the No-action Alternative HEC-ResSim Model described in Section 3. This section describes changes to the NAA modeled for each alternative. Section 5, Alternative Non-Exceedance Plots, provides figures showing the results for each alternative compared to NAA. Not all measures included in each alternative are modeled in HEC-ResSim. Only measures that result in changes to reservoir elevations, total outflows, and outlet-specific outflows are modeled.

Some measures allocate reservoir releases to multiple outlets in ways that are not effectively modeled in HEC-ResSim. Those flow allocations are calculated in excel spreadsheets outside of the HEC-ResSim model. The logic for the reallocation of flow in excel is also provided in this section.

4.1 Alternative 1 Modeling Assumptions

4.1.1 Measure 392

Measure 392 has a minimum flow of 600 cfs over the spillway year-round at FOS. Measure 479 (Section 4.1.2) requires an additional release of 144 cfs in May and 72 cfs in June. Station service requires 150 cfs through the penstock. Measure 497 and Measure 392 minimums are combined with the station service flow into a single minimum flow rule at GPR targeting the flow out of Foster Dam and Reservoir (Figure 4-1).

Measure 392 minimum flow requirements at other projects were not modeled because other minimum flows in Alternative 1 are higher.

*Willamette Valley System Operations and Maintenance
Environmental Impact Statement*

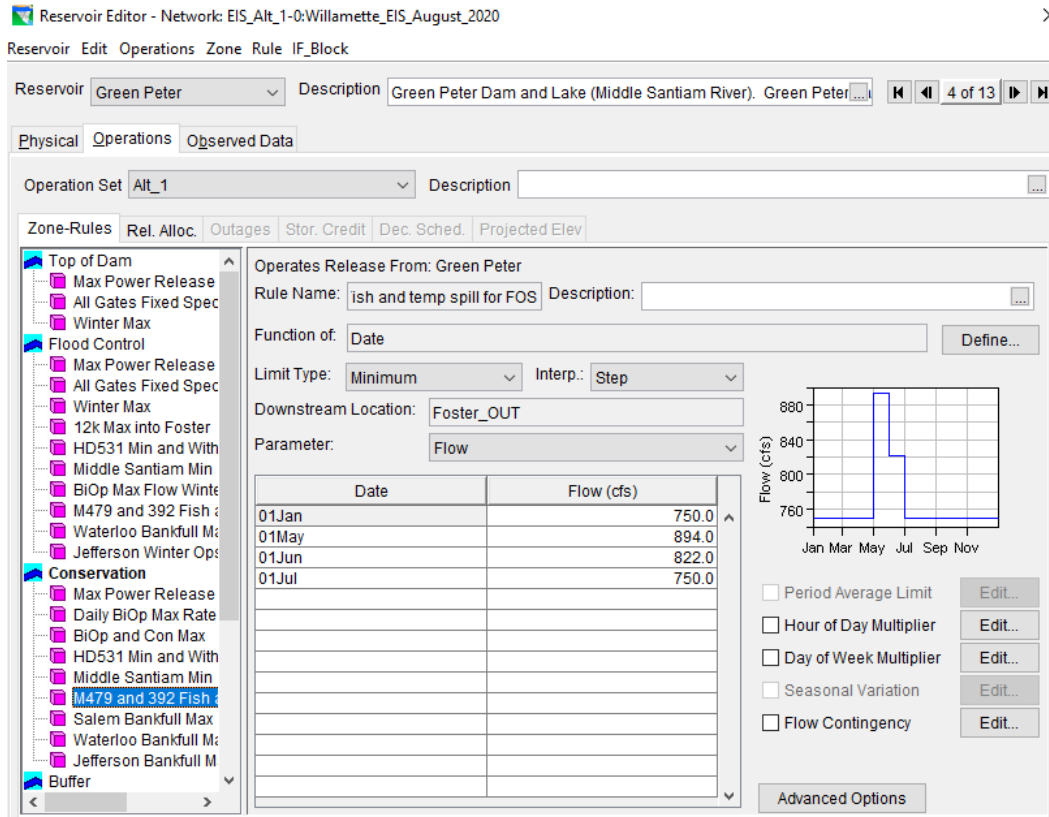

Figure 4-1. Measure 479, Measure 392, and Station Service Target Below FOS from GPR.

4.1.2 Measure 479

Measure 479 calls for a temperature control pipe at Foster Dam requiring a minimum flow of 144 in May and 72 in June through a new outlet. This release was defined as going over the spillway instead of making a new outlet. This was noted when passing results to other models. This operation can only occur when FOS is above 630 feet. Foster Dam and Reservoir follows the Rule Curve unless Green Peter Dam and Reservoir completely empties in this model so that restriction is adhered to. Outflow for this measure is added to minimum spill required for Measure 392 as shown in Figure 4-1. Flow is allocated to the correct outlet at Foster Dam in MS Excel with logic that adheres to outlet minimum and maximum releases without changing total project outflow.

4.1.3 Measure 105

Measure 105 calls for a temperature control tower at Detroit Dam and Reservoir that will replace the temperature spill operation in the NAA that allocates flow over the spillway and through the regulating outlet. The re-allocation of flow at Detroit Dam and Reservoir in the NAA was post processed in MS Excel but for Alt 1, the flow re-allocation was used directly from HEC-ResSim Temperature control towers at other projects do not change total flow or outlet-specific flow from the NAA and are not modeled.

4.1.4 Measure 718

The inactive zone at Cottage Grove, Dorena, Fall Creek, and Blue River Dams and Reservoirs is lowered to an elevation 10 feet above the regulating outlet to permit drafting into the inactive pool to meet minimum tributary and mainstem targets. An additional zone labeled the “no draft” zone delineates the minimum desired drafting elevation. Below this elevation there is a rule that prevents a reduction in pool elevation, and the minimum tributary rule. Drafting below the minimum conservation elevation is permitted from 01Jun until 20Dec. If elevations are below minimum conservation elevation on 20Dec, HEC-ResSim will release inflow until inflow is greater than the minimum flow, at which time the reservoir elevation will rise. An example water control diagram showing the bottom of the newly available storage is shown in Figure 4-2.

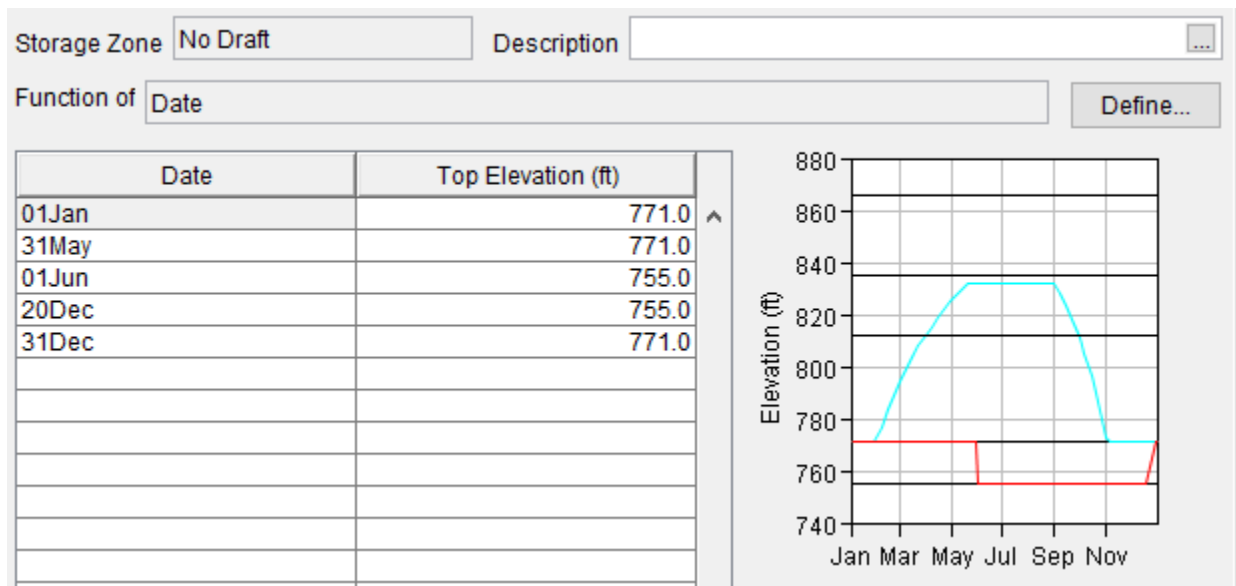

Figure 4-2. Measure 718 Draft Limit at Dorena Dam and Reservoir.

4.1.5 Measure 304

Measure 304 lowers the inactive zone at Lookout Point, Hills Creek, Cougar, and Green Peter Dams and Reservoirs to permit drafting to the bottom of the power pool to meet minimum tributary and mainstem targets. An additional zone labeled the “no draft” zone delineates the minimum permissible drafting elevation. Below this elevation there is a rule that prevents a reduction in pool elevation, and the minimum tributary rule. Drafting below the minimum conservation elevation is permitted from 01Jun until 20Dec. If elevations are below minimum conservation elevation on 20Dec, HEC-ResSim will release inflow until inflow is greater than the minimum flow, at which time the reservoir elevation will rise. An example water control diagram showing the bottom of the newly available storage is shown in Figure 4-3.

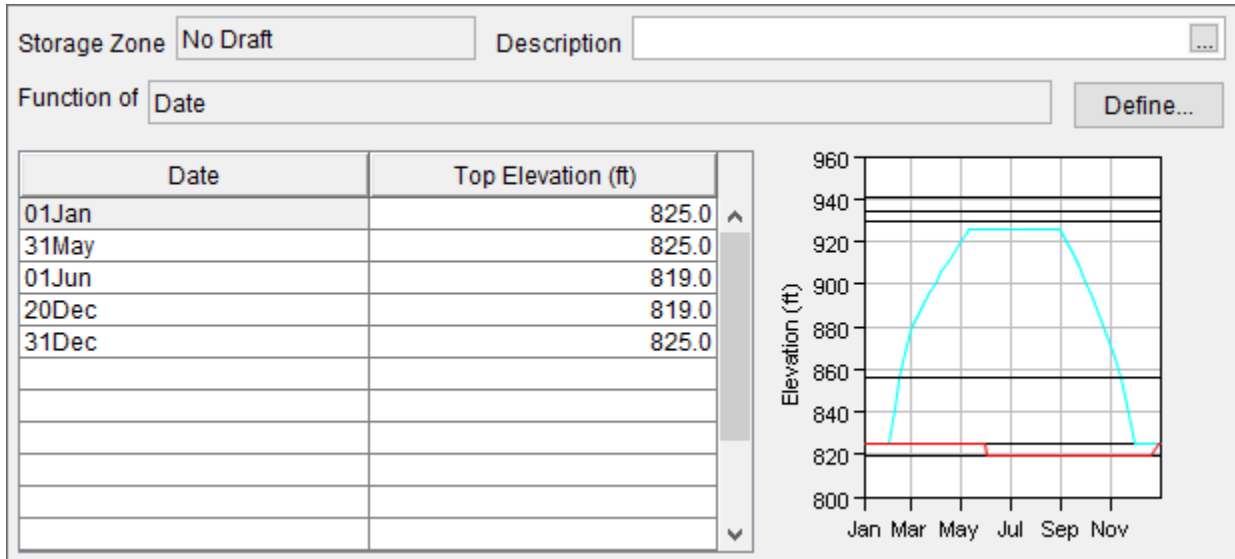

Figure 4-3. Measure 304 Draft Limit at Lookout Point Dam and Reservoir.

4.1.6 Measure 723

This measure replaces the NAA minimum Biological Opinion flows (NMFS 2008) with HD531 minimum tributary flows at all projects (Figure 4-4) and on the mainstem (Table 4-1). HD531 tributary flows are only defined 01Feb-30Nov, but the lowest HD531 min is applied for the remainder of the year so that there is always a minimum flow rule to prevent zero outflows when the downstream control point is above bank full. Contributions to withdrawals are added to these minimum flows when above the minimum conservation elevation but are not added when below the minimum conservation elevation. Withdrawals are the same in the watershed in every year because there is no option in HEC-ResSim to adjust a withdrawal downstream when a given reservoir drafts below a certain limit. Physical minimums defined at some reservoirs may be larger than the HD531 + contribution to withdrawals and will be the controlling minimum flow.

HD 531 flows predate Foster Reservoir and anticipated Cascadia Reservoir would be built on the South Santiam. To account for this, the minimum flows below Foster Dam and Reservoir are the sum of the Green Peter and Cascadia Dams and Reservoirs minimum flows. The minimum flow in the middle Santiam directly below Green Peter Dam and Reservoir is defined as 50 cfs.

Willamette Valley System Operations and Maintenance
Environmental Impact Statement

TABLE III-1.—Minimum flows adopted for preservation of fish

Mean monthly flows in second-feet					
Location	Filling season February–June		Low-water season July–November		Remarks
	Minimum observed ¹ (1926–45)	Adopted minimum for fish	Minimum observed (1926–45)	Adopted minimum for fish	
Cottage Grove Dam.....	55	75	11	50	Fish not a major problem.
Dorena Dam site.....	140	190	20	100	Do.
Hills Creek Dam site.....	510	100	196	100	Do.
Meridian Dam site.....	1,360	1,200	517	1,000	Anadromous fish a problem.
Fall Creek Dam site.....	125	30	17	30	Fish not a major problem.
Cougar Dam site.....	425	300	141	200	Anadromous fish a problem.
Blue River Dam site.....	164	30	16	30	Fish not a major problem.
Gate Creek Dam site.....	93	20	10	20	Do.
Fern Ridge Dam.....	73	50	9	30	Do.
Tumtum Dam site.....	16	20	3	20	Do.
Holley Dam site.....	110	50	15	50	Do.
Cascadia Dam site.....	220	300	28	100	Anadromous fish a problem.
Green Peter Dam site.....	447	² 500	51	300	Do.
Wiley Creek Dam site.....	50	30	8	30	Fish not a major problem.
Detroit Dam site.....	1,245	1,000	445	750	Anadromous fish a problem.
Lewisville Dam site.....	40	20	7	20	Fish not a major problem.
Monroe.....	100	³ 50	12	³ 30	Do.
Waterloo.....	862	³ 600	111	³ 600	Anadromous fish a problem.
Mehama.....	1,750	³ 300	405	³ 300	Do.

¹ Minimum observed flow is for May rather than for the period February–June.
² At Green Peter, minimum regulated for May=450 second-feet; for June=300 second-feet.
³ Water released for irrigation projects below Monroe, Waterloo, and Mehama Reservoirs is in addition to the minimum values shown.

NOTES.—1. At the power reservoirs (Meridian, Hills Creek, Cougar, Green Peter, and Detroit) the releases during the power season (October–March, inclusive) are substantially greater than the minimum regulated flows shown. 2. The minimum observed and regulated flows (1926–45) for each month of the year at each of the above stations are shown in table III-8.

Figure 4-4. Measure 723 HD531 Minimum Tributary Flows.

Table 4-1. HD531 Mainstem Targets.

Control Point	Date	Augmentation for Fish Habitat and Water Quality (cfs) (per HD 531)
Salem	Jun 1 - Nov 30	6,500
Albany	Jun 1 - Nov 30	5,000

4.1.7 Measure 174

Measure 174 calls for structural modifications to manage total dissolved gasses below reservoirs. These modifications will not change total outflow or outlet-specific flow and are not modeled.

4.1.8 Measure 722

Measure 722 addresses fish facilities. This does not change total outflow or outlet-specific outflow and is not modeled.

4.1.9 Measure 52

Measure 52 addresses lamprey passage. This does not change total outflow or outlet-specific outflow and is not modeled.

4.1.10 Basin-wide Measures 9, 384, 719, 726

These basin-wide measures do not change total outflow or outlet-specific outflow and are not modeled.

4.2 Alternatives 2A and 2B Modeling Assumptions

Modeling assumptions for Alternatives 2A and 2B are detailed below. The modeled differences between Alternatives 2A and 2B are limited to Cougar Reservoir. Alternative 2A has no fall or spring drawdown at Cougar Reservoir whereas alternative 2B has a deep spring and fall drawdown to 1,330 feet. Cougar Reservoir targets a minimum tributary flow of 300 cfs and will not contribute explicitly to mainstem targets in Alternative 2B.

Table 4-2. Alternatives 2A and 2B Drawdowns.

Alternative	Drawdown	GPR	CGR
2A	Spring	<i>No</i>	<i>No</i>
2A	Fall	780'	<i>No</i>
2B	Spring	<i>No</i>	1,330'
2B	Fall	780'	1,330'

4.2.1 Measure 30

Measure 30 defines minimum tributary flows out of Lookout Point, Cougar, Green Peter, and Detroit Dams and Reservoirs based on percent reservoir storage being either greater than or less than 90 percent, relative to the rule curve, evaluated every 2 weeks between 01Feb and 01Jun. The 01Jun percent full determination sets the flow regime for the remainder of the year. An example is shown in Figure 4-5. The remaining reservoirs maintain the 2008 Biological Opinion (NMFS 2008) minimum flow schedule with additions for the NAA abundant water year contributions to withdrawals.

Mainstem flow targets at Salem are defined to meet water temperature targets as defined by Measure 30, developed as a function of 7-day max air temperature at Salem using methods described by Stratton Garvin et al. (2021). The rule in HEC-ResSim is shown in Figure 4-6. There are also base minimum mainstem flow targets of 4,500 cfs at Albany and 5,000 cfs at Salem. Hills Creek, Lookout Point, Fall Creek, Cottage Grove, Dorena, Cougar, and Blue River Dams and Reservoirs contribute to mainstem targets.

Cougar Dam and Reservoir has a deep spring drawdown under Alternative 2B. Under Alternative 2B, Cougar Dam and Reservoir will have a tributary minimum of 300 cfs and will not explicitly contribute additional flow to supplement mainstem targets.

*Willamette Valley System Operations and Maintenance
Environmental Impact Statement*

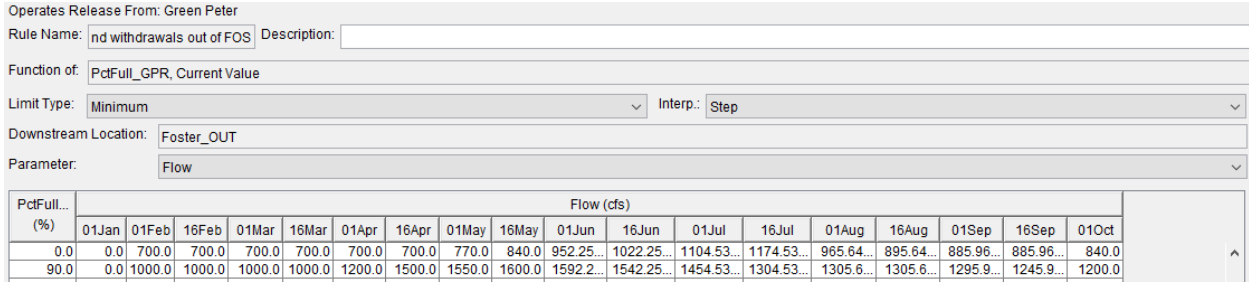

Figure 4-5. Measure 30 Minimum Tributary Flow at Green Peter Dam and Reservoir.

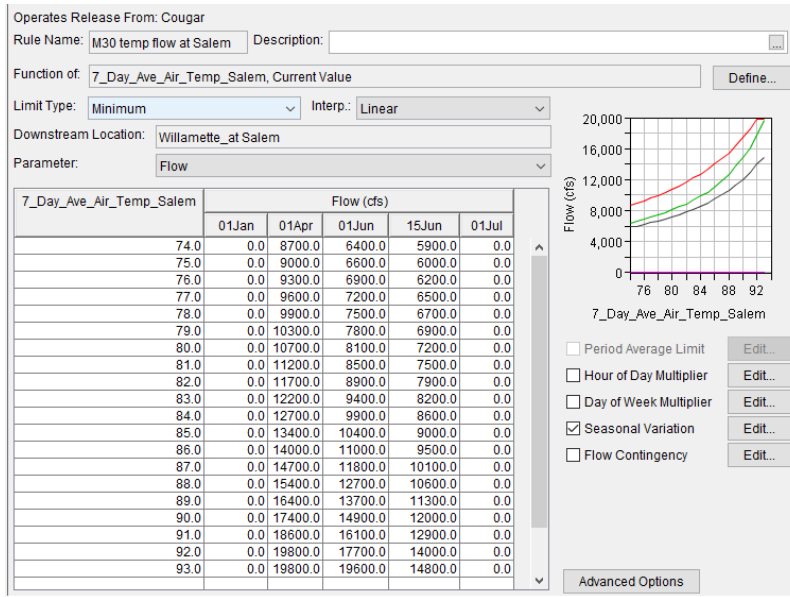

Figure 4-6. Measure 30 Temperature Minimum Flow at Salem.

4.2.2 Measure 721

Measure 721 calls for spill over the spillway at Green Peter Dam and Reservoir in the spring. If above spillway in the spring after 15April, 60 percent of the flow is released over the spillway until 15Nov, or until the reservoir drafts below the spillway. This re-allocation of flow is post processed in MS Excel outside of HEC-ResSim. Total outflow is not changed.

4.2.3 Measure 166

Measure 166 calls for spill through the regulating outlet in the fall at Green Peter Dam and Reservoir. After 01Oct, if below the spillway, release 60 percent of flow through the regulating outlet until 15Nov. The fall drawdown targets an elevation below the minimum power pool on or about 01Oct which results in all flow going through the regulating outlet. This re-allocation of flow is post processed in MS Excel outside of HEC-ResSim. Total outflow is not changed.

4.2.4 Measure 714

Measure 714 calls for all flow at Green Peter Dam and Reservoir to go over the spillway when greater than 25 feet over the spillway May-July. The spring temperature spill operation (Measure 721) takes precedence over this spill operation, so this operation is not modeled.

4.2.5 Measure 720

Measure 720 calls for a drawdown to 1,330 feet at Cougar Dam and Reservoir in Alternative 2B. When below the minimum conservation elevation of 1,532 feet, Cougar Dam and Reservoir will draft at a rate no greater than 3ft/day. The drawdown will begin on 01 March and refill will begin on 15 June. The penstock will not be used for 1/3 of the day when within 50 feet of the saddle leading to the penstock and regulating outlet inlet works. The conservation season target elevation at Cougar Dam and Reservoir, including the spring drawdown, is identified in Figure 4-7.

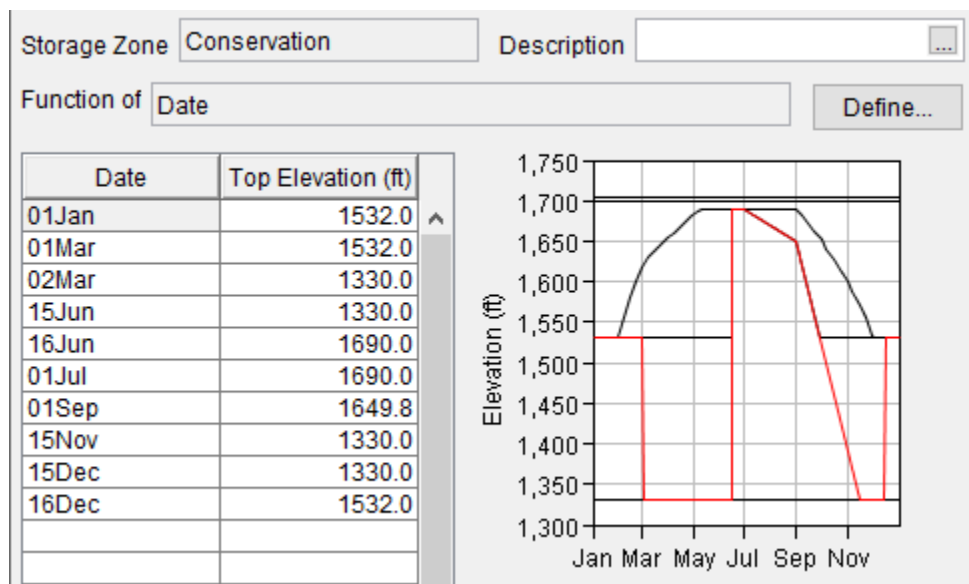

Figure 4-7. Cougar Dam and Reservoir Spring and Fall Drawdown Target Elevations.

4.2.6 Measure 40

Measure 40 calls for a fall drawdown at Green Peter Dam and Reservoir to 780 feet and at Cougar Dam and Reservoir to 1,330 feet in Alternative 2B. Alternative 2A does not have a fall drawdown at Cougar Dam and Reservoir. Drafting at Cougar Dam and Reservoir is limited to a maximum release of 5,000 cfs when below 1,532 feet. The Green Peter Dam and Reservoir fall drawdown target elevation is shown in Figure 4-8. The Cougar Dam and Reservoir fall drawdown elevation is shown in Figure 4-7.

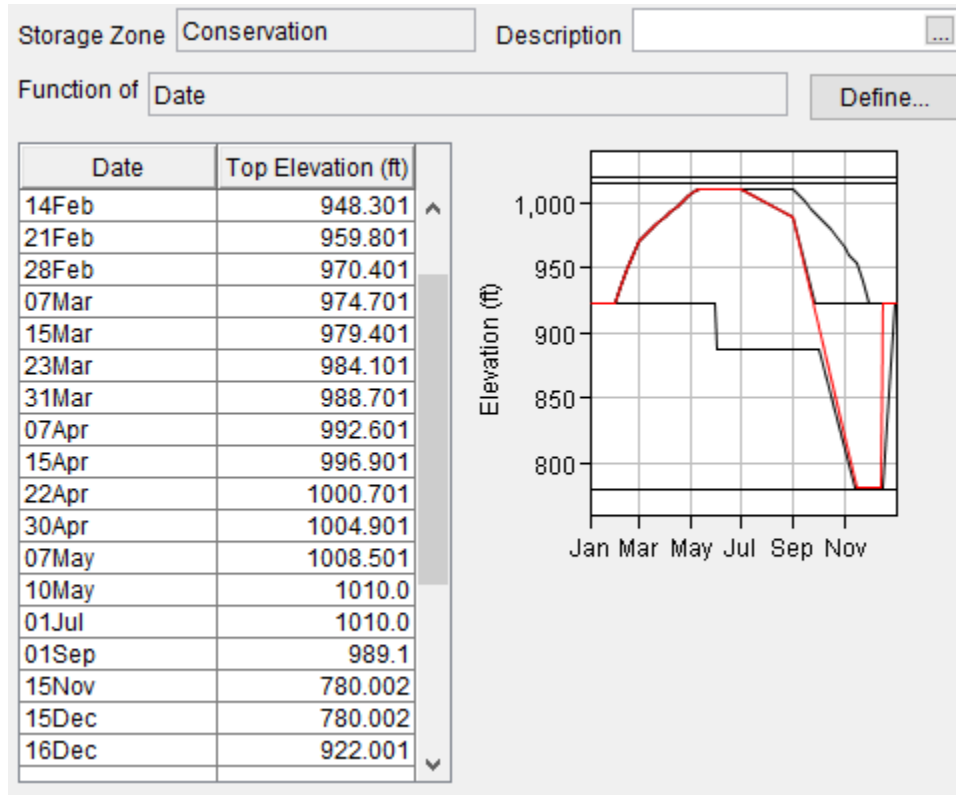

Figure 4-8. Green Peter Dam and Reservoir Fall Drawdown Target Elevation.

4.2.7 Measure 718

The inactive zone at, Fall Creek, and Blue River Dams and Reservoirs is lowered to an elevation 10 feet above the regulating outlet to permit drafting into the inactive pool to meet minimum tributary and mainstem targets. This operation is not applied at Fern Ridge Dam and Reservoir because of the shallow storage/elevation profile. This operation is not applied at Cottage Grove or Dorena Dams and Reservoirs in Alternative 5 because model results showed unrealistic drafting during the fall conservation season drawdown in previous alternatives. An additional zone labeled the “no draft” zone delineates the minimum desired drafting elevation. Below this elevation there is a rule that prevents a reduction in pool elevation, and the minimum tributary rule. Drafting below the minimum conservation elevation is permitted from 01Jun until 20Dec. If elevations are below minimum conservation elevation on 20Dec, HEC-ResSim will release inflow until inflow is greater than the minimum flow, at which time the reservoir elevation will rise. An example water control diagram showing the bottom of the newly available storage is shown in Figure 4-2.

4.2.8 Measure 304

Measure 304 lowers the inactive zone at Lookout Point, Hills Creek, Cougar, Detroit, and Green Peter Dams and Reservoirs to permit drafting to the bottom of the power pool to meet minimum tributary and mainstem targets. An additional zone labeled the “no draft” zone delineates the minimum permissible drafting elevation. Below this elevation there is a rule that

prevents a reduction in pool elevation, and the minimum tributary rule. Drafting below the minimum conservation elevation is permitted from 01Jun until 20Dec. If elevations are below minimum conservation elevation on 20Dec, HEC-ResSim will release inflow until inflow is greater than the minimum flow, at which time the reservoir elevation will rise. An example water control diagram showing the bottom of the newly available storage is shown in Figure 4-3.

4.2.9 Measure 105

Measure 105 calls for a temperature control tower at Detroit Dam and Reservoir that will replace the temperature spill operation in the NAA that allocates flow over the spillway and through the regulating outlet. The re-allocation of flow at Detroit Dam and Reservoir in the NAA was post processed in MS Excel, but for Alternatives 2A and 2B, the flow re-allocation was used directly from HEC-ResSim. Temperature control towers at other projects do not change total flow or outlet-specific flow from the NAA and are not modeled.

4.2.10 Measure 392

Measure 392 has a minimum flow of 600 cfs over the spillway year-round at FOS. Measure 479 (Section 4.1.2) requires an additional release of 144 cfs in May and 72cfs in June. Station service requires 150 cfs through the penstock. Measure 479 and Measure 392 minimums are combined with the station service flow into a single minimum flow rule at GPR targeting the flow out of Foster Dam and Reservoir (Figure 4-1).

Measure 392 minimum flow requirements at other projects were not modeled because other minimum flows in Alternatives 2A and 2B are higher.

4.2.11 Measure 479

Measure 479 calls for a temperature control pipe at Foster Dam and Reservoir requiring a minimum flow of 144 in May and 72 in June through a new outlet. This release will be defined as going over the spillway instead of making a new outlet. Outflow for this measure is added to minimum spill required for Measure 392 as shown in Figure 4-1. Flow is allocated to the correct outlet at Foster Dam and Reservoir in MS Excel with logic that adheres to outlet minimum and maximum releases without changing total project outflow.

4.2.12 Measure 722

Measure 722 addresses fish facilities. This does not change total outflow or outlet-specific outflow and is not modeled.

4.2.13 Measure 52

Measure 52 addresses lamprey passage. This does not change total outflow or outlet-specific outflow and is not modeled.

4.2.14 Basin-wide Measures 9, 384, 719, 726

These basin-wide measures do not change total outflow or outlet-specific outflow and are not modeled.

4.3 Alternatives 3A and 3B Modeling Assumptions

Modeling assumptions for 3A and 3B are detailed below. The modeled differences between Alternatives 3A and 3B are limited to changes in the locations of fall and spring drawdowns as identified in Table 4-3. Locations with spring drawdowns will not explicitly supplement mainstem flows and will release for dry year tributary targets.

Table 4-3. Alternatives 3A and 3B Drawdowns.

Alternative	Drawdown	BLU	HCR	GPR	DET	LOP	CGR
3A	Spring	<i>No</i>	<i>No</i>	<i>No</i>	1,375'	761'	1,517'
3A	Fall	1,165'	1,446'	780'	1,375'	761'	1,517'
3B	Spring	<i>No</i>	1,446'	780'	<i>No</i>	<i>No</i>	1,330'
3B	Fall	1,165'	1,446'	780'	1,375'	761'	1,330'

4.3.1 Measure 30

Measure 30 defines minimum tributary flows out of Lookout Point, Cougar, Green Peter, and Detroit Dams and Reservoirs based on percent reservoir storage being either greater than or less than 90 percent, relative to the rule curve, evaluated every 2 weeks between 01Feb and 01Jun. The 01Jun percent full determination sets the flow regime for the remainder of the year. An example is shown in Figure 4-5. The remaining reservoirs maintain the 2008 Biological Opinion (NMFS 2008) minimum flow schedule with additions for the NAA abundant water year contributions to withdrawals.

Mainstem flow targets at Salem are determined by an external daily timeseries of the future average 7-day max air temp. The rule in HEC-ResSim is shown in Figure 4-6. There are also base minimum mainstem flow targets of 4,500 cfs at Albany and 5,000 cfs at Salem. Hills Creek, Lookout Point, Fall Creek, Cottage Grove, Dorena, Cougar, and Blue River Dams and Reservoirs contribute to mainstem targets.

Reservoirs with spring drawdowns will not contribute explicitly to mainstem targets. Reservoirs with spring drawdowns will release the minimum flow designated when less than 90 percent of the rule curve. Table 4-3 indicates locations of fall and spring drawdowns.

Cougar Dam and Reservoir has a deep spring drawdown under Alternative 3B. Under Alternative 3B, Cougar Dam and Reservoir will have a tributary minimum of 300 cfs and will not explicitly contribute additional flow to supplement mainstem targets.

4.3.2 Measure 721

Measure 721 calls for spill over the spillway in spring at Lookout Point, Hills Creek, Blue River, and Green Peter Dams and Reservoirs. If above spillway in the spring after 15April, 60 percent of the flow is released over the spillway until 15Nov, or until the reservoir drafts below the spillway. This is identical to the NAA spring spill operation at Detroit Dam and Reservoir, which is also included in Alternatives 3A and 3B. This re-allocation of flow is post processed in MS Excel outside of HEC-ResSim. Total outflow is not changed.

Reservoirs with spring drawdowns will not have spring spill operations. Refer to Table 4-3 to identify reservoirs with spring drawdowns in Alternative 3A and Alternative 3B.

4.3.3 Measure 166

Measure 166 calls for spill through the regulating outlet in the fall at Green Peter and Lookout Point Dams and Reservoirs. After 01Oct, release 60 percent of flow through the regulating outlet until 15Nov. This is identical to the NAA fall spill operation at Detroit Dam and Reservoir, which is also included in Alternative 3A and Alternative 3B. Penstock flow is to be further reduced to one-third of the day when within 25 feet of the penstock and eliminated when below the minimum power pool. This re-allocation of flow is post processed in MS Excel outside of HEC-ResSim. Total outflow is not changed.

4.3.4 Measure 714

Measure 714 calls for all flow to go over the spillway when greater than 25 feet over the spillway, May–July. The spring temperature spill operation (Measure 721) takes precedence over this spill operation, so this operation is only modeled at Dexter, Big Cliff, and Fall Creek Dams and Reservoirs. Flow is allocated to the correct outlet in MS Excel with logic that adheres to outlet minimum and maximum releases without changing total project outflow.

4.3.5 Measure 720

Measure 720 defines spring drawdowns as indicated Table 4-3. Projects will draft no more than 3ft/day When below the minimum conservation elevation. The drawdown will begin on 01 March at each project, refill will begin on 21 May at Green Peter Dam and Reservoir, and refill on 15 June at the other projects. The penstock will not be used for one-third of the day when within 50 feet of the regulating outlet at Cougar and Hills Creek Dams and Reservoirs or within 25 feet of the penstock at other projects. An example of a spring and fall drawdown target elevation curve is shown in Figure 4-7.

4.3.6 Measure 40

Measure 40 defines fall drawdowns as indicated Table 4-3. Projects will draft no more than 3ft/day when below the minimum conservation elevation. The penstock will not be used for one-third of the day when within 50 feet of the regulating outlet at Cougar and Hills Creek Dams and Reservoirs or within 25 feet of the penstock at other projects. A spring and fall

drawdown target elevation curve is shown in Figure 4-7. An example of a fall drawdown only is shown in Figure 4-8.

4.3.7 Measure 718

The inactive zone at Cottage Grove, Dorena, Fall Creek, and Blue River Dams and Reservoirs is lowered to an elevation 10 feet above the regulating outlet to permit drafting into the inactive pool to meet minimum tributary and mainstem targets. An additional zone labeled the “no draft” zone delineates the minimum desired drafting elevation. Below this elevation there is a rule that prevents a reduction in pool elevation, and the minimum tributary rule. Drafting below the minimum conservation elevation is permitted from 01Jun until 20Dec. If elevations are below minimum conservation elevation on 20Dec, HEC-ResSim will release inflow until inflow is greater than the minimum flow, at which time the reservoir elevation will rise. An example water control diagram showing the bottom of the newly available storage is shown in Figure 4-2.

4.3.8 Measure 304

Measure 304 lowers the inactive zone at Lookout Point, Hills Creek, Cougar, Detroit, and Green Peter Dams and Reservoirs to permit drafting to the bottom of the power pool to meet minimum tributary and mainstem targets. An additional zone labeled the “no draft” zone delineates the minimum permissible drafting elevation. Below this elevation there is a rule that prevents a reduction in pool elevation, and the minimum tributary rule. Drafting below the minimum conservation elevation is permitted from 01Jun until 20Dec. If elevations are below minimum conservation elevation on 20Dec, HEC-ResSim will release inflow until inflow is greater than the minimum flow, at which time the reservoir elevation will rise. Hills Creek Dam and Reservoir will not draft below 1,446 feet to facilitate the volitional fish passage operation. An example water control diagram showing the bottom of the newly available storage is shown in Figure 4-3.

4.3.9 Measure 722

Measure 722 addresses fish facilities. This does not change total outflow or outlet-specific outflow and is not modeled.

4.3.10 Measure 52

Measure 52 addresses lamprey passage. This does not change total outflow or outlet-specific outflow and is not modeled.

4.3.11 Basin-wide Measures 9, 384, 719, 726

These basin-wide measures do not change total outflow or outlet-specific outflow and are not modeled.

4.4 Alternative 4 Modeling Assumptions

4.4.1 Measure 30

Measure 30 defines minimum tributary flows out of Lookout Point, Cougar, Green Peter, and Detroit Dams and Reservoirs based on percent reservoir storage being either greater than or less than 90 percent, relative to the rule curve, evaluated every 2 weeks between 01Feb and 01Jun. The 01Jun percent full determination sets the flow regime for the remainder of the year. An example is shown in Figure 4-5. The remaining reservoirs maintain the 2008 Biological Opinion (NMFS 2008) minimum flow schedule with additions for the NAA abundant water year contributions to withdrawals.

Mainstem flow targets at Salem are determined by an external daily timeseries of the future average 7-day max air temp. The rule in HEC-ResSim is shown in Figure 4-6. There are also base minimum mainstem flow targets of 4,500 cfs at Albany and 5,000 cfs at Salem. Hills Creek, Lookout Point, Fall Creek, Cottage Grove, Dorena, Cougar, and Blue River Dams and Reservoirs contribute to mainstem targets.

4.4.2 Measure 721

Measure 721 calls for spill over the spillway at Green Peter Dam and Reservoir in the spring. If above spillway in the spring after 15April, 60 percent of the flow is released over the spillway until 15Nov, or until the reservoir drafts below the spillway. This re-allocation of flow is post processed in MS Excel outside of HEC-ResSim. Total outflow is not changed.

4.4.3 Measure 166

Measure 166 calls for spill through the regulating outlet in the fall at Green Peter Dam and Reservoir. After 01Oct, if below the spillway, release 60 percent of flow through the regulating outlet until 15Nov. The fall drawdown targets an elevation below the minimum power pool on or about 01Oct which results in all flow going through the regulating outlet. This re-allocation of flow is post processed in MS Excel outside of HEC-ResSim. Total outflow is not changed.

4.4.4 Measure 392

Measure 392 has a minimum flow of 600 cfs over the spillway year-round at FOS. Measure 479 (described in Section 4.1.2) requires an additional release of 144 cfs in May and 72 cfs in June. Station service requires 150 cfs through the penstock. Measure 497 and Measure 392 minimums are combined with the station service flow into a single minimum flow rule at GPR targeting the flow out of Foster Dam and Reservoir (Figure 4-1).

Measure 392 minimum flow requirements at other projects were not modeled because other minimum flows in Alternative 4 are higher.

4.4.5 Measure 479

Measure 479 calls for a temperature control pipe at Foster Dam requiring a minimum flow of 144 in May and 72 in June through a new outlet. This release will be defined as going over the spillway instead of making a new outlet. This will be noted when passing results to other models. This operation can only occur when FOS is above 630 feet. Foster Dam and Reservoir follows the Rule Curve unless Green Peter Dam and Reservoir completely empties in this model so that restriction is adhered to. Outflow for this measure is added to minimum spill required for Measure 392 as shown in Figure 4-1. Flow is allocated to the correct outlet at Foster Dam in MS Excel with logic that adheres to outlet minimum and maximum releases without changing total project outflow.

4.4.6 Measure 105

Measure 105 calls for a temperature control tower at Detroit Dam and Reservoir that will replace the temperature spill operation in the NAA that allocates flow over the spillway and through the regulating outlet. The re-allocation of flow at Detroit Dam and Reservoir in the NAA was post processed in MS Excel, but for Alternative 4, the flow re-allocation was used directly from HEC-ResSim. Temperature control towers at other projects do not change total flow or outlet-specific flow from the NAA and are not modeled.

4.4.7 Measure 718

The inactive zone at Cottage Grove, Dorena, Fall Creek, and Blue River Dams and Reservoirs is lowered to an elevation 10 feet above the regulating outlet to permit drafting into the inactive pool to meet minimum tributary and mainstem targets. An additional zone labeled the “no draft” zone delineates the minimum desired drafting elevation. Below this elevation there is a rule that prevents a reduction in pool elevation, and the minimum tributary rule. Drafting below the minimum conservation elevation is permitted from 01Jun until 20Dec. If elevations are below minimum conservation elevation on 20Dec, HEC-ResSim will release inflow until inflow is greater than the minimum flow, at which time the reservoir elevation will rise. An example water control diagram showing the bottom of the newly available storage is shown in Figure 4-2.

4.4.8 Measure 304

Measure 304 lowers the inactive zone at Lookout Point, Hills Creek, Cougar, Detroit, and Green Peter Dams and Reservoirs to permit drafting to the bottom of the power pool to meet minimum tributary and mainstem targets. An additional zone labeled the “no draft” zone delineates the minimum permissible drafting elevation. Below this elevation there is a rule that prevents a reduction in pool elevation, and the minimum tributary rule. Drafting below the minimum conservation elevation is permitted from 01Jun until 20Dec. If elevations are below minimum conservation elevation on 20Dec, HEC-ResSim will release inflow until inflow is greater than the minimum flow, at which time the reservoir elevation will rise. An example

water control diagram showing the bottom of the newly available storage is shown in Figure 4-3.

4.4.9 Measure 174

Measure 174 calls for structural modifications to manage total dissolved gasses below reservoirs. These modifications will not change total outflow or outlet-specific flow and are not modeled.

4.4.10 Measure 711

Measure 711 calls for mechanical de-gassing at reservoir outlets that will not change total flow or outlet-specific outflow and is not modeled.

4.4.11 Measure 722

Measure 722 addresses fish facilities. This does not change total outflow or outlet-specific outflow and is not modeled.

4.4.12 Measure 52

Measure 52 addresses lamprey passage. This does not change total outflow or outlet-specific outflow and is not modeled.

4.4.13 Basin-wide Measures 9, 384, 719, 726

These basin-wide measures do not change total outflow or outlet-specific outflow and are not modeled.

4.5 Alternative 5 Modeling Assumptions

4.5.1 Measure 30b

Measure 30b defines minimum tributary flows out of Lookout Point, Cougar, Green Peter, and Detroit Dams and Reservoirs based on percent reservoir storage being either greater than or less than 90 percent, relative to the rule curve, evaluated every 2 weeks between 01Feb and 01Jun. The 01Jun percent full determination sets the flow regime for the remainder of the year. These tributary targets are identical to Measure 30 except at Green Peter Dam and Reservoir (Figure 4-9).

The mainstem flow targets at Salem are a function of an external annual timeseries which designates a year based on the percentile of normal unregulated flow at Salem achieved in a year (Figure 4-10), and an external daily timeseries of the future average 7-day max air temp shown in Figure 4-6. The Albany target is 4,500 cfs.

*Willamette Valley System Operations and Maintenance
Environmental Impact Statement*

The remaining reservoirs maintain the 2008 Biological Opinion (NMFS 2008) minimum flow schedule with additions for the NAA abundant water year contributions to withdrawals.

Cougar Dam and Reservoir has a deep spring drawdown in Alternative 5. In Alternative 5, Cougar Dam and Reservoir will have a tributary minimum of 300 cfs and will not explicitly contribute additional flow to supplement mainstem targets.

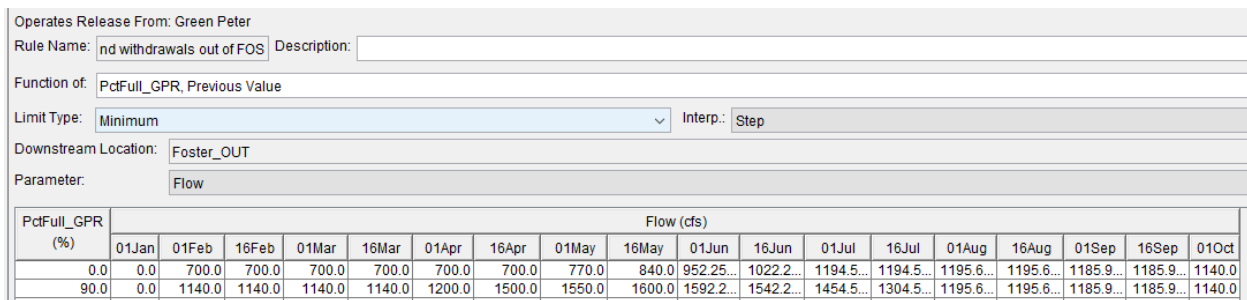

Figure 4-9. Measure 30b Minimum Tributary Flow at Green Peter Dam and Reservoir.

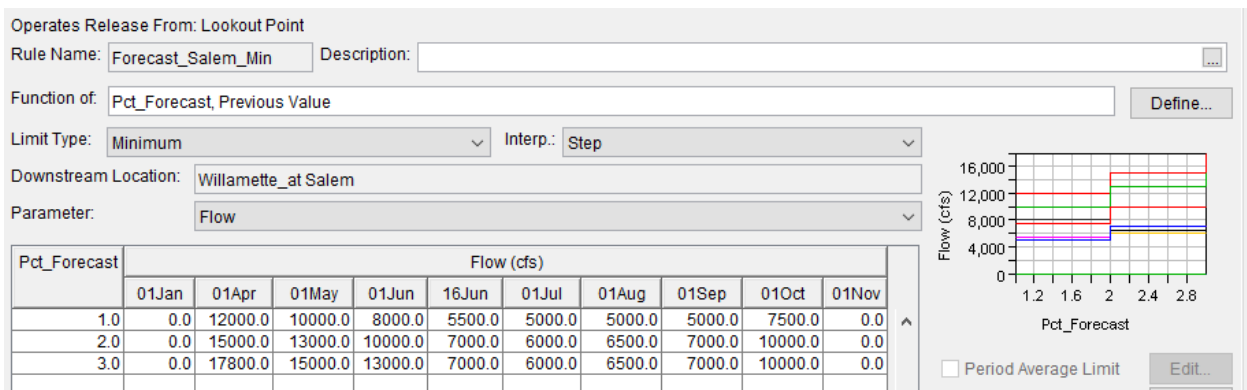

Figure 4-10. Measure 30b Forecast Minimum Flow at Salem.

4.5.2 Measure 721

Measure 721 calls for spill over the spillway at Green Peter Dam and Reservoir in the spring. If above the spillway in the spring after 15April, 60 percent of the flow is released over the spillway until 15Nov, or until the reservoir drafts below the spillway. This re-allocation of flow is post processed in MS Excel outside of HEC-ResSim. Total outflow is not changed.

4.5.3 Measure 166

Measure 166 calls for spill through the regulating outlet in the fall at Green Peter Dam and Reservoir. After 01Oct, if below the spillway, release 60 percent of flow through the regulating outlet until 15Nov. The fall drawdown targets an elevation below the minimum power pool on or about 01Oct which results in all flow going through the regulating outlet. This re-allocation of flow is post-processed in MS Excel outside of HEC-ResSim. Total outflow is not changed.

4.5.4 Measure 714

Measure 714 calls for all flow at Green Peter Dam and Reservoir to go over the spillway when greater than 25 feet over the spillway May–July. The spring temperature spill operation (Measure 721) takes precedence over this spill operation, so this operation is not modeled.

4.5.5 Measure 720

Measure 720 calls for a drawdown to 1,330 feet at Cougar Dam and Reservoir. When below the minimum conservation elevation of 1,532 feet Cougar Dam and Reservoir will draft at a rate no greater than 5,000 cfs. The drawdown will begin on 01 March and refill will begin on 15 June. The penstock will not be used for one-third of the day when within 50 feet of the saddle leading to the penstock and regulating outlet inlet works. The conservation season target elevation at Cougar Dam and Reservoir, including the spring drawdown, is identified in Figure 4-7.

4.5.6 Measure 40

Measure 40 calls for a fall drawdown at Green Peter Dam and Reservoir to 780 feet and at Cougar Dam and Reservoir to 1,330 feet. Drafting at Cougar Dam and Reservoir is limited to a maximum release of 5,000 cfs when below 1,532 feet. The Green Peter Dam and Reservoir fall drawdown target elevation is shown in Figure 4-8. The Cougar Dam and Reservoir fall drawdown elevation is shown in Figure 4-7.

4.5.7 Measure 718

The inactive zone at Fall Creek and Blue River Dams and Reservoirs is lowered to an elevation 10 feet above the regulating outlet to permit drafting into the inactive pool to meet minimum tributary and mainstem targets. This operation is not applied at Fern Ridge Dam and Reservoir because of the shallow storage/elevation profile. This operation is not applied at Cottage Grove or Dorena Dams and Reservoirs in Alternative 5 because model results showed unrealistic drafting during the fall conservation season drawdown in previous alternatives. An additional zone labeled the “no draft” zone delineates the minimum desired drafting elevation. Below this elevation there is a rule that prevents a reduction in pool elevation, and the minimum tributary rule. Drafting below the minimum conservation elevation is permitted from 01Jun until 20Dec. If elevations are below minimum conservation elevation on 20Dec, HEC-ResSim will release inflow until inflow is greater than the minimum flow, at which time the reservoir elevation will rise. An example water control diagram showing the bottom of the newly available storage is shown in Figure 4-2.

4.5.8 Measure 304

Measure 304 lowers the inactive zone at Lookout Point, Hills Creek, Cougar, Detroit, and Green Peter Dams and Reservoirs to permit drafting to the bottom of the power pool to meet minimum tributary and mainstem targets. An additional zone labeled the “no draft” zone delineates the minimum permissible drafting elevation. Below this elevation there is a rule that

prevents a reduction in pool elevation, and the minimum tributary rule. Drafting below the minimum conservation elevation is permitted from 01Jun until 20Dec. If elevations are below minimum conservation elevation on 20Dec, HEC-ResSim will release inflow until inflow is greater than the minimum flow, at which time the reservoir elevation will rise. An example water control diagram showing the bottom of the newly available storage is shown in Figure 4-3.

4.5.9 Measure 105

Measure 105 calls for a temperature control tower at Detroit Dam and Reservoir that will replace the temperature spill operation in the NAA that allocates flow over the spillway and through the regulating outlet. The re-allocation of flow at Detroit Dam and Reservoir in the NAA was post processed in MS Excel, but for Alternative 5, the flow re-allocation was used directly from HEC-ResSim. Temperature control towers at other projects do not change total flow or outlet-specific flow from the NAA and are not modeled.

4.5.10 Measure 392

Measure 392 has a minimum flow of 600 cfs over the spillway year-round at Foster Dam and Reservoir. Measure 479 (Section 4.1.2) requires an additional release of 144 cfs in May and 72 cfs in June. Station service requires 150 cfs through the penstock. Measure 479 and Measure 392 minimums are combined with the station service flow into a single minimum flow rule at GPR targeting the flow out of Foster Dam and Reservoir (Figure 4-1).

Measure 392 minimum flow requirements at other projects were not modeled because other minimum flows in Alternative 5 are higher.

4.5.11 Measure 479

Measure 479 calls for a temperature control pipe at Foster Dam and Reservoir requiring a minimum flow of 144 in May and 72 in June through a new outlet. This release will be defined as going over the spillway instead of making a new outlet. Outflow for this measure is added to minimum spill required for Measure 392 as shown in Figure 4-1. Flow is allocated to the correct outlet at Foster Dam and Reservoir in MS Excel with logic that adheres to outlet minimum and maximum releases without changing total project outflow.

4.5.12 Measure 722

Measure 722 addresses fish facilities. This does not change total outflow or outlet-specific outflow and is not modeled.

4.5.13 Measure 52

Measure 52 addresses lamprey passage. This does not change total outflow or outlet-specific outflow and is not modeled.

4.5.14 Basin-wide Measures 9, 384, 719, 726

These basin-wide measures do not change total outflow or outlet-specific outflow and are not modeled.

4.6 Alternative 6 Modeling Assumptions

4.6.1 No Hydropower Assumption

Alternative 6 assumes no hydropower is generated at Willamette Valley Projects, except for the private hydropower facility at Dorena, which is not modeled. In this alternative, the penstocks still release the same amount of water as they would if hydropower were generated. The assumption is that the penstocks would be reconfigured in a way that permits these releases.

4.6.2 Measure 721

Measure 721 calls for spill over the spillway at Green Peter Dam and Reservoir in the spring. If above the spillway in the spring after 15April, 60 percent of the flow is released over the spillway until 15Nov, or until the reservoir drafts below the spillway. This re-allocation of flow is post processed in MS Excel outside of HEC-ResSim. Total outflow is not changed.

4.6.3 Measure 166

Measure 166 calls for spill through the regulating outlet in the fall at Green Peter Dam and Reservoir. After 01Oct, if below the spillway, release 60 percent of flow through the regulating outlet until 15Nov. The fall drawdown targets an elevation below the minimum power pool on or about 01Oct which results in all flow going through the regulating outlet. This re-allocation of flow is post-processed in MS Excel outside of HEC-ResSim. Total outflow is not changed.

4.6.4 Measure 714

Measure 714 calls for all flow at Green Peter Dam and Reservoir to go over the spillway when greater than 25 feet over the spillway May–July. The spring temperature spill operation (Measure 721) takes precedence over this spill operation, so this operation is not modeled.

4.6.5 Measure 720

Measure 720 calls for a drawdown to 1,330 feet at Cougar Dam and Reservoir. When below the minimum conservation elevation of 1,532 feet Cougar Dam and Reservoir will draft at a rate no greater than 5,000 cfs. The drawdown will begin on 01 March and refill will begin on 15 June. The penstock will not be used for one-third of the day when within 50 feet of the saddle leading to the penstock and regulating outlet inlet works. The conservation season target elevation at Cougar Dam and Reservoir, including the spring drawdown, is identified in Figure 4-7.

4.6.6 Measure 40

Measure 40 calls for a fall drawdown at Green Peter Dam and Reservoir to 780 feet and at Cougar Dam and Reservoir to 1,330 feet. Drafting at Cougar Dam and Reservoir is limited to a maximum release of 5,000 cfs when below 1,532 feet. The Green Peter Dam and Reservoir fall drawdown target elevation is shown in Figure 4-8. The Cougar Dam and Reservoir fall drawdown elevation is shown in Figure 4-7.

4.6.7 Measure 718

The inactive zone at Fall Creek and Blue River Dams and Reservoirs is lowered to an elevation 10 feet above the regulating outlet to permit drafting into the inactive pool to meet minimum tributary and mainstem targets. This operation is not applied at Fern Ridge Dam and Reservoir because of the shallow storage/elevation profile. This operation is not applied at Cottage Grove or Dorena Dams and Reservoirs in Alternative 6 because model results showed unrealistic drafting during the fall conservation season drawdown in previous alternatives. An additional zone labeled the “no draft” zone delineates the minimum desired drafting elevation. Below this elevation there is a rule that prevents a reduction in pool elevation, and the minimum tributary rule. Drafting below the minimum conservation elevation is permitted from 01Jun until 20Dec. If elevations are below minimum conservation elevation on 20Dec, HEC-ResSim will release inflow until inflow is greater than the minimum flow, at which time the reservoir elevation will rise. An example water control diagram showing the bottom of the newly available storage is shown in Figure 4-2.

4.6.8 Measure 304

Measure 304 lowers the inactive zone at Lookout Point, Hills Creek, Cougar, Detroit, and Green Peter Dams and Reservoirs to permit drafting to the bottom of the power pool to meet minimum tributary and mainstem targets. An additional zone labeled the “no draft” zone delineates the minimum permissible drafting elevation. Below this elevation there is a rule that prevents a reduction in pool elevation, and the minimum tributary rule. Drafting below the minimum conservation elevation is permitted from 01Jun until 20Dec. If elevations are below minimum conservation elevation on 20Dec, HEC-ResSim will release inflow until inflow is greater than the minimum flow, at which time the reservoir elevation will rise. An example water control diagram showing the bottom of the newly available storage is shown in Figure 4-3.

4.6.9 Measure 105

Measure 105 calls for a temperature control tower at Detroit Dam and Reservoir that will replace the temperature spill operation in the NAA that allocates flow over the spillway and through the regulating outlet. The re-allocation of flow at Detroit Dam and Reservoir in the NAA was post processed in MS Excel, but for Alternative 6, the flow re-allocation was used directly from HEC-ResSim. Temperature control towers at other projects do not change total flow or outlet-specific flow from the NAA and are not modeled.

4.6.10 Measure 392

Measure 392 has a minimum flow of 600 cfs over the spillway year-round at Foster Dam and Reservoir. Measure 479 (Section 4.1.2) requires an additional release of 144 cfs in May and 72 cfs in June. Station service requires 150 cfs through the penstock. Measure 479 and Measure 392 minimums are combined with the station service flow into a single minimum flow rule at GPR targeting the flow out of Foster Dam and Reservoir (Figure 4-1).

Measure 392 minimum flow requirements at other projects were not modeled because other minimum flows in Alternative 6 are higher.

4.6.11 Measure 479

Measure 479 calls for a temperature control pipe at Foster Dam and Reservoir requiring a minimum flow of 144 in May and 72 in June through a new outlet. This release will be defined as going over the spillway instead of making a new outlet. Outflow for this measure is added to minimum spill required for Measure 392 as shown in Figure 4-1. Flow is allocated to the correct outlet at Foster Dam and Reservoir in MS Excel with logic that adheres to outlet minimum and maximum releases without changing total project outflow.

4.6.12 Measure 722

Measure 722 addresses fish facilities. This does not change total outflow or outlet-specific outflow and is not modeled.

4.6.13 Measure 52

Measure 52 addresses lamprey passage. This does not change total outflow or outlet-specific outflow and is not modeled.

4.7 Interim Operations Modeling Assumptions

4.7.1 Measure 30b

Measure 30b defines minimum tributary flows out of Lookout Point, Cougar, Green Peter, and Detroit Dams and Reservoirs based on percent reservoir storage being either greater than or less than 90 percent, relative to the rule curve, evaluated every 2 weeks between 01Feb and 01Jun. The 01Jun percent full determination sets the flow regime for the remainder of the year. These tributary targets are identical to Measure 30 except at Green Peter Dam and Reservoir (Figure 4-11).

The mainstem flow targets at Salem are a function of an external annual timeseries which designates a year based on the percentile of normal unregulated flow at Salem achieved in a year (Figure 4-12), and an external daily timeseries of the future average 7-day max air temp shown in Figure 4-6. The Albany target is 4,500 cfs.

*Willamette Valley System Operations and Maintenance
Environmental Impact Statement*

The remaining reservoirs maintain the 2008 Biological Opinion (NMFS 2008) minimum flow schedule with additions for the NAA abundant water year contributions to withdrawals.

Cougar Dam and Reservoir has a deep spring drawdown in Alternative 5. In Alternative 5, Cougar Dam and Reservoir will have a tributary minimum of 300 cfs and will not explicitly contribute additional flow to supplement mainstem targets.

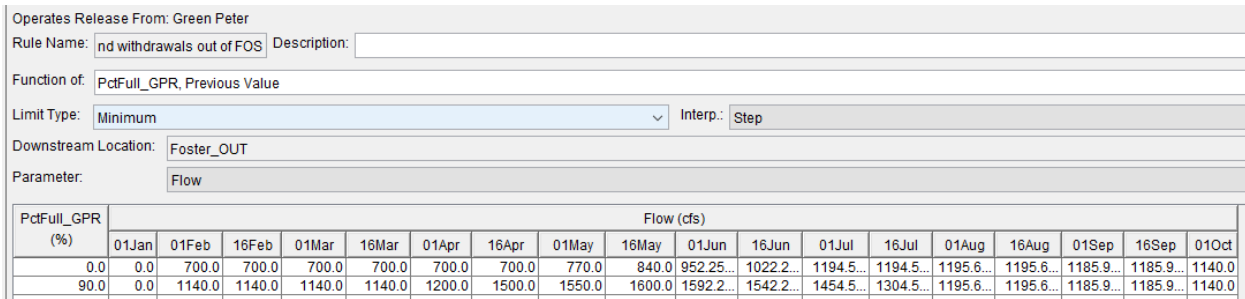

Figure 4-11. Measure 30b Minimum Tributary Flow at Green Peter Dam and Reservoir.

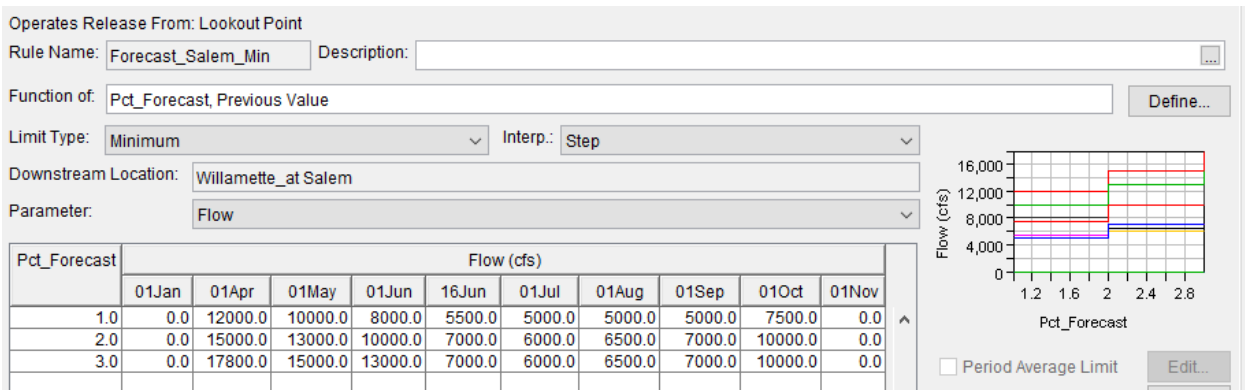

Figure 4-12. Measure 30b Forecast Minimum Flow at Salem.

4.7.2 Detroit Dam and Reservoir

When pool levels rise above 1,541 feet in the spring, release 75 percent of the flow over the spillway until pool levels drop below 1,541 feet in the fall. When pool levels drop below the spillway crest, release 75 percent of the flow through the regulating outlet.

4.7.3 Green Peter Dam and Reservoir

In the spring, when elevations rise to 971 feet, release 100 percent of the flow over the spillway until 01May. Release a minimum of 800 cfs when above the spillway.

In the fall, target an elevation of 780 feet on 15Nov. Achieve this by beginning the drawdown on 01Sep. Target 780 feet on 15Nov until 15Dec. Target minimum conservation elevation of 922 feet on 16Dec and follow the rule curve until the next drawdown (Figure 4-13).

*Willamette Valley System Operations and Maintenance
Environmental Impact Statement*

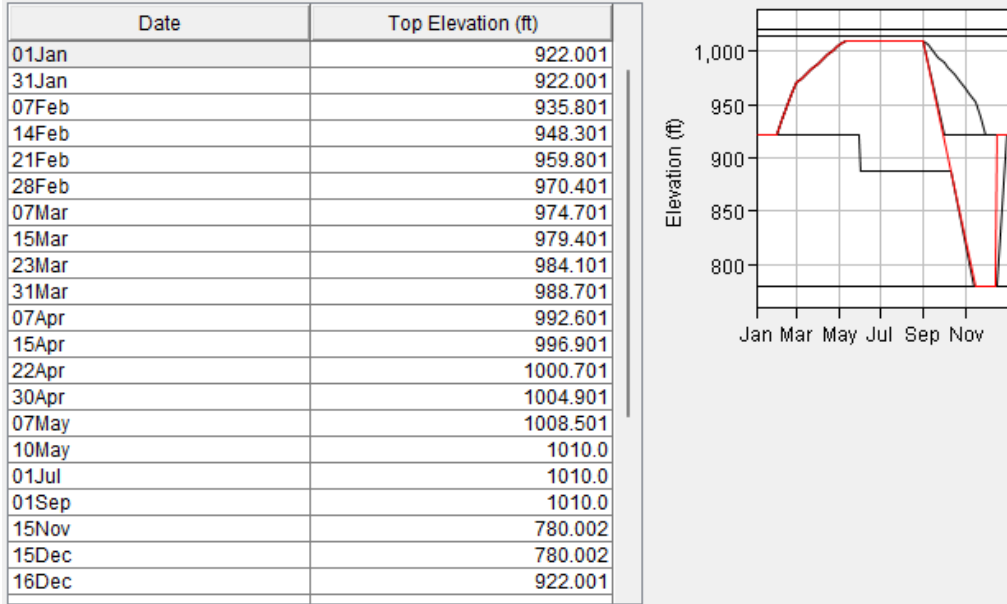

Figure 4-13. Green Peter Dam and Reservoir Fall Drawdown Target Elevation.

4.7.4 Foster Dam and Reservoir

Delay refill until 15May, target 637 feet between 16May and Labor Day (05Sep), target 620 feet on 01Oct until meeting rule curve on 07Nov (Figure 4-14). Target the rule curve until the following spring. Release 60 percent of flow over the spillway from 01Feb to 15Jun and 01Oct to 15Dec. Additionally, 300 cfs is released over the spillway from 16Jun to 31Jul.

*Willamette Valley System Operations and Maintenance
Environmental Impact Statement*

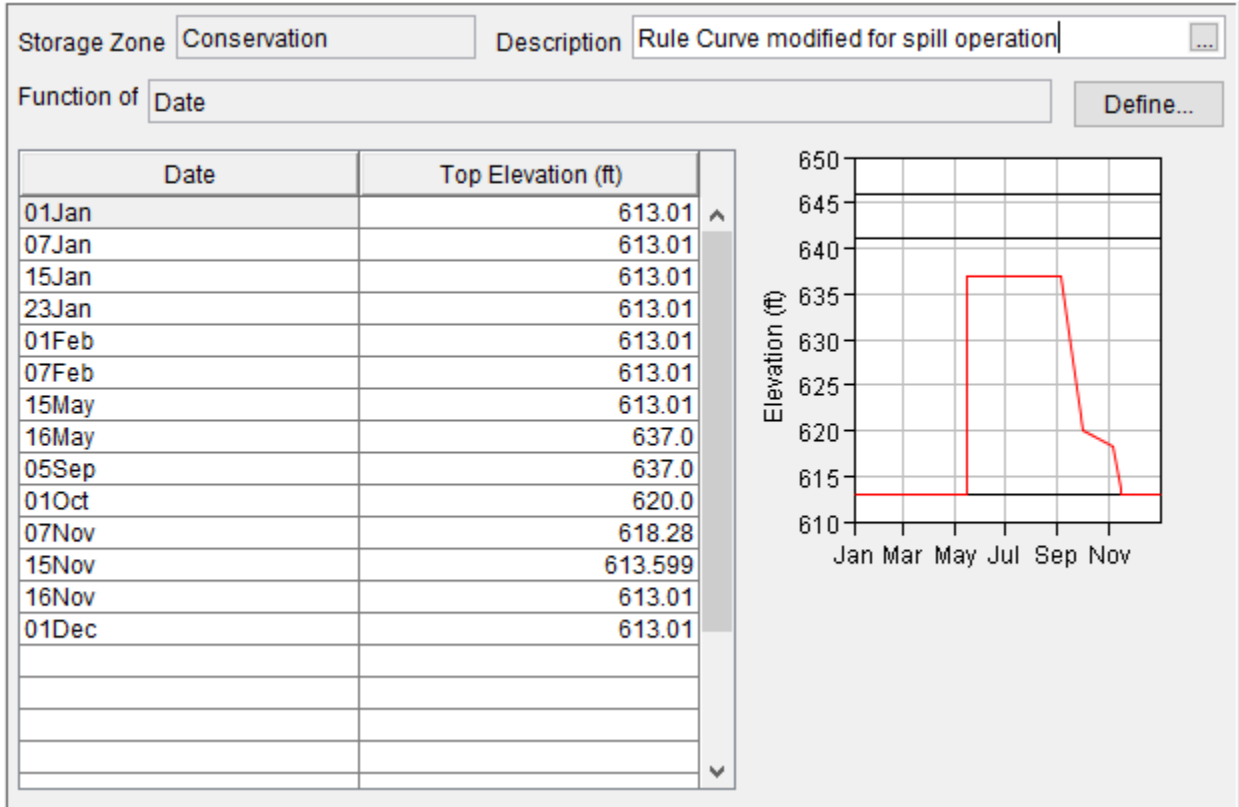

Figure 4-14. Foster Dam and Reservoir Interim Operations Target Elevation.

4.7.5 Cougar Dam and Reservoir

Delay refill targeting 1,520 feet between 01Feb and 15May, then target rule curve until initiating a fall drawdown beginning 01Jul targeting the 01Oct elevation on 01Sep, then targeting 1,505 feet from 15Nov to 15Dec. On 16Dec, target rule curve until following spring. Release of flow through RO between 01Feb and 15May or whenever below 1,580 feet (Figure 4-15). Limit daily average releases during the spring delayed refill and fall drawdown to 2,000 cfs to reflect the average of night and day regulating outlet limitations to reduce TDG. Additionally, there is an 880 cfs release limit in September.

Willamette Valley System Operations and Maintenance
Environmental Impact Statement

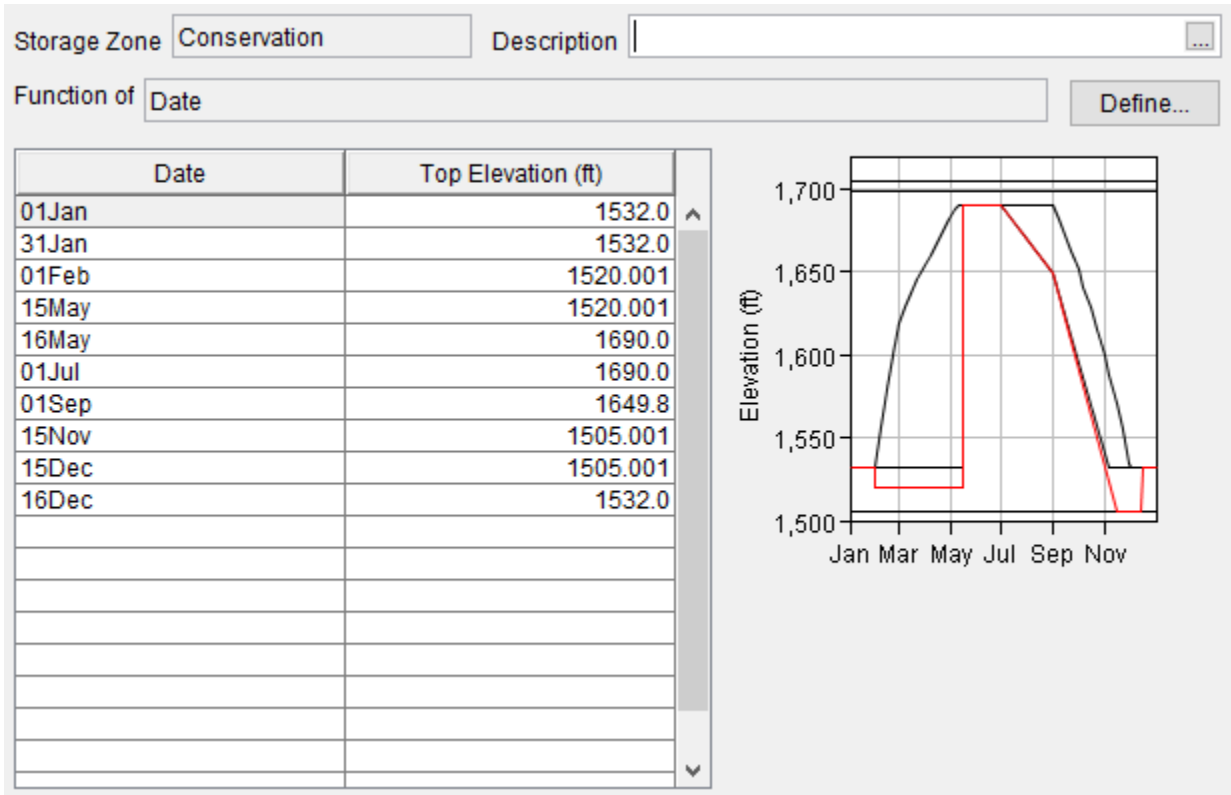

Figure 4-15. Cougar Spring and Fall Drawdown Target Elevation.

4.7.6 Hills Creek Dam and Reservoir

Release from Hills Creek Dam and Reservoir to promote filling at Lookout Point Dam and Reservoir in the spring by releasing 1,000 cfs instead of 400 cfs if Lookout Point Reservoir is below 95 percent full until May. Release 17 percent of flow through the regulating outlet when the reservoir is within 50 feet of the regulating outlet 01Oct through 01Mar. Penstock maximum restrictions may result in higher regulating outlet releases, and all flow will be released through the regulating outlet if Hills Creek Dam and Reservoir drafts below the minimum power pool. Hills Creek Dam and Reservoir will draft during the winter to provide minimum flow requirements below Lookout Point Dam and Reservoir.

4.7.7 Lookout Point Dam and Reservoir

Prioritize refill at Lookout Point Dam and Reservoir using released storage from Hills Creek Dam and Reservoir. Refill to 893 feet in the spring and target 893 feet until 01July. Once above 893 feet, release all flow over the spillway until 01May and 60 percent of the flow over the spillway until 31May. Release 60 percent of the flow through the regulating outlet after 15Jul until reaching the minimum power pool, after which all flow will go through the regulating outlet. Target 750 feet from 15Nov to 15Dec. After 15Dec, target the rule curve until the following spring (Figure 4-16).

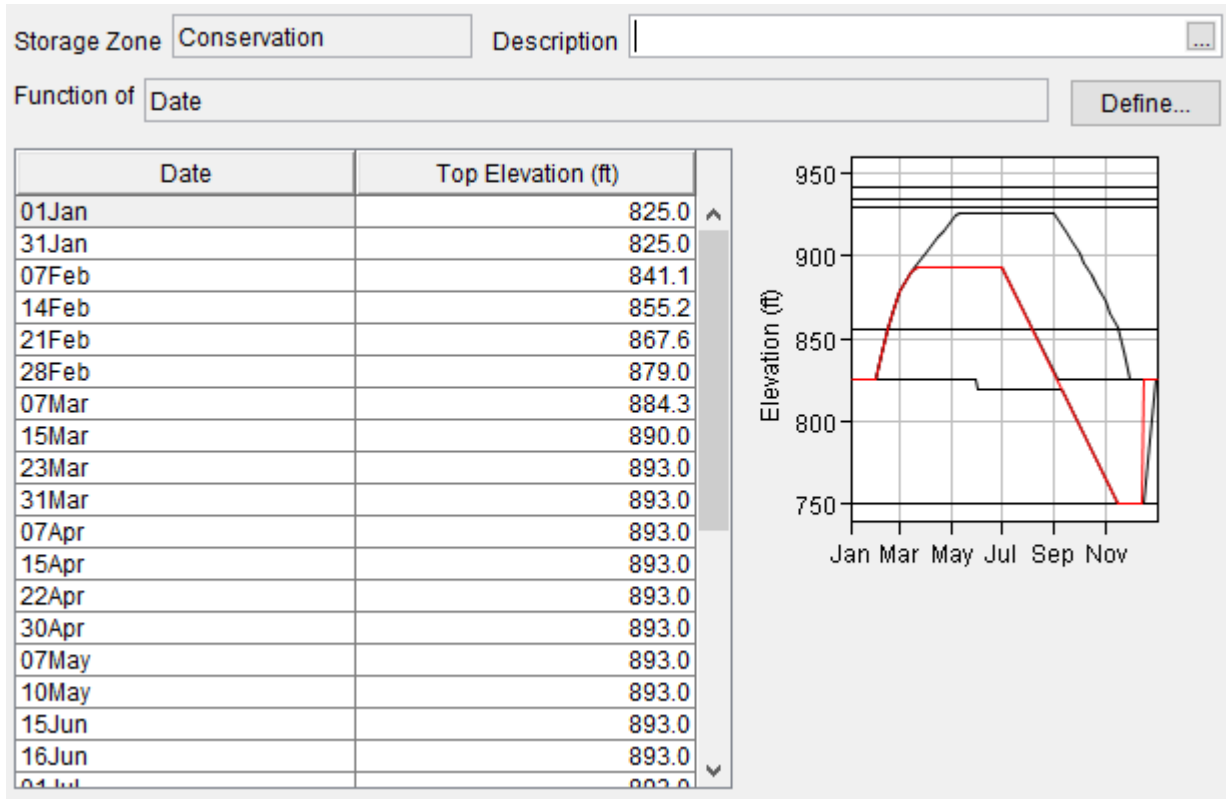

Figure 4-16. Lookout Point Interim Operations Target Elevation.

4.7.8 Dexter Dam and Reservoir

Release all flow over spillway when fish spill is happening at Lookout Point Dam and Reservoir.

4.7.9 Fall Creek Dam and Reservoir

There is no specific Interim Operation at Fall Creek Reservoir; therefore, model parameters are the same as those described for the NAA.

4.8 Updated Interim Operations Modeling Assumptions

The Interim Operations were updated after the FEIS was completed in April 2025 to incorporate a deep fall/winter drawdown at Detroit Dam and Reservoir and use of the 2008 Biological Opinion minimum flow targets basin wide. The minimum flow targets are the same as the NAA.

4.8.1 Detroit Dam and Reservoir

When pool levels rise above 1,541 feet in the spring, release 75 percent of the flow over the spillway until pool levels drop below 1,541 feet in the fall. When pool levels drop below the spillway crest, release 75 percent of the flow through the regulating outlet.

Drafting below 1450 feet to 1425 feet is permitted from 01Jun to 01Dec to meet minimum flows. The main revision to the Interim Operations is the addition of a deep fall drawdown

*Willamette Valley System Operations and Maintenance
Environmental Impact Statement*

targeting 1395 feet beginning 01Dec until 01Jan (Figure 4-17). A maximum release of 5,000 cfs is permitted when below 1450' to achieve the drawdown.

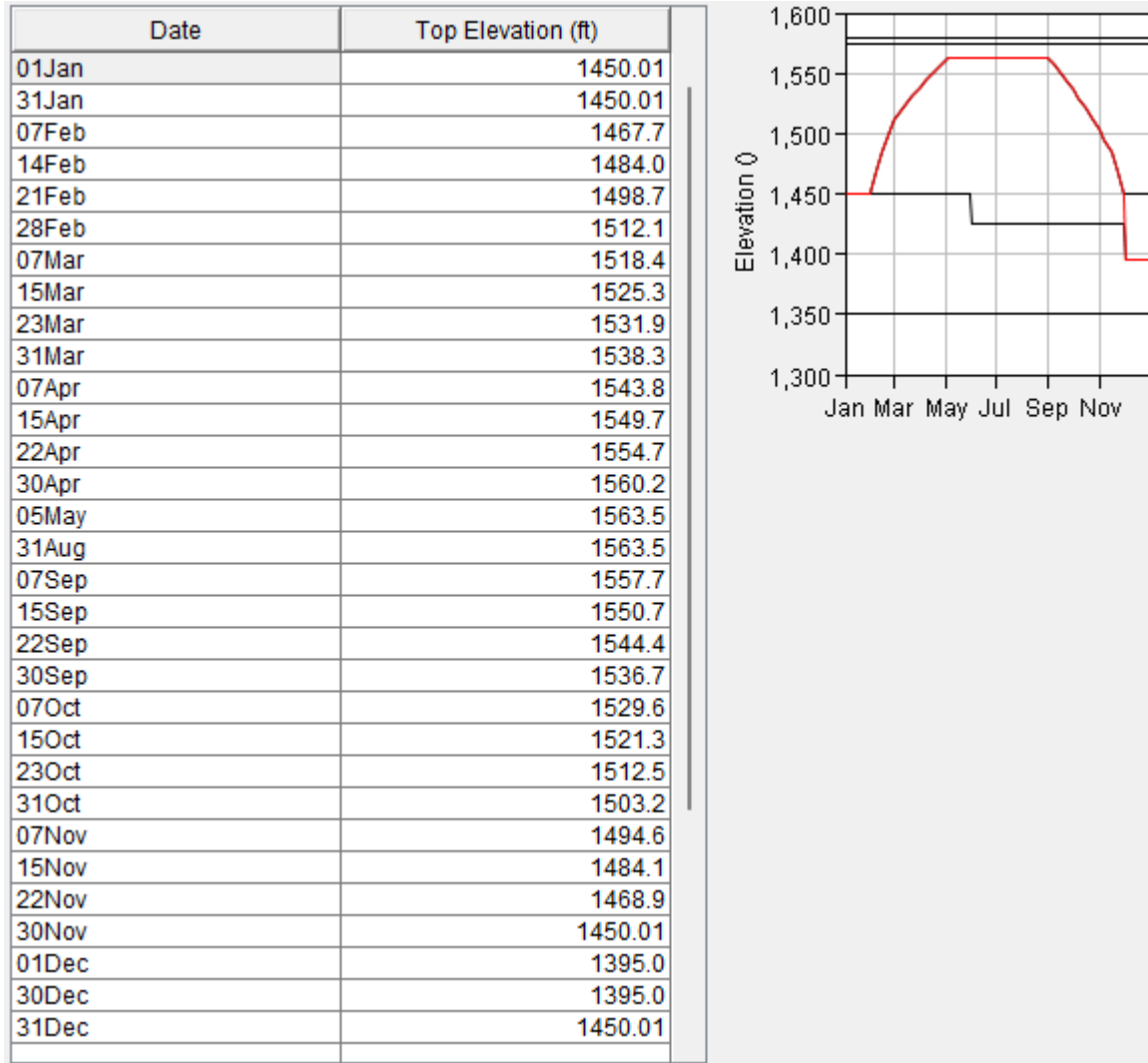

Figure 4-17. Detroit Reservoir Interim Operations Target Elevation.

4.8.2 Green Peter Dam and Reservoir

In the spring, when elevations rise to 971 feet, release 100 percent of the flow over the spillway until 01May. Release a minimum of 800 cfs when above the spillway.

In the fall, target an elevation of 780 feet on 15Nov. Achieve this by beginning the drawdown on 01Sep. Target 780 feet on 15Nov until 15Dec. Target minimum conservation elevation of 922 feet on 16Dec and follow the rule curve until the next drawdown (Figure 4-18).

*Willamette Valley System Operations and Maintenance
Environmental Impact Statement*

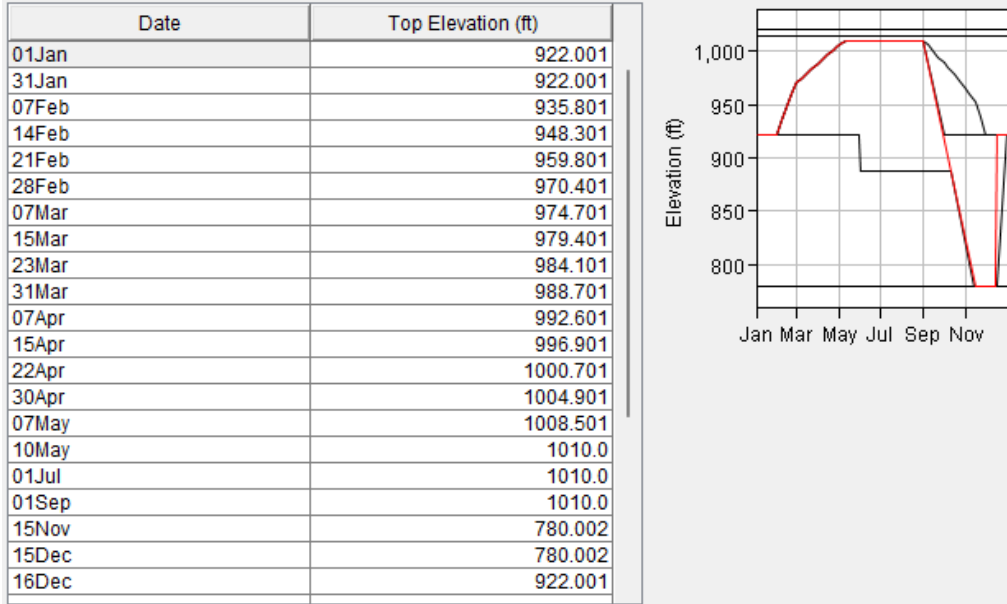

Figure 4-18. Green Peter Dam and Reservoir Fall Drawdown Target Elevation.

4.8.3 Foster Dam and Reservoir

Delay refill until 15May, target 637 feet between 16May and Labor Day (05Sep), target 620 feet on 01Oct until meeting rule curve on 07Nov (Figure 4-19). Target the rule curve until the following spring. Release 60 percent of flow over the spillway from 01Feb to 15Jun and 01Oct to 15Dec. Additionally, 300 cfs is released over the spillway from 16Jun to 31Jul.

*Willamette Valley System Operations and Maintenance
Environmental Impact Statement*

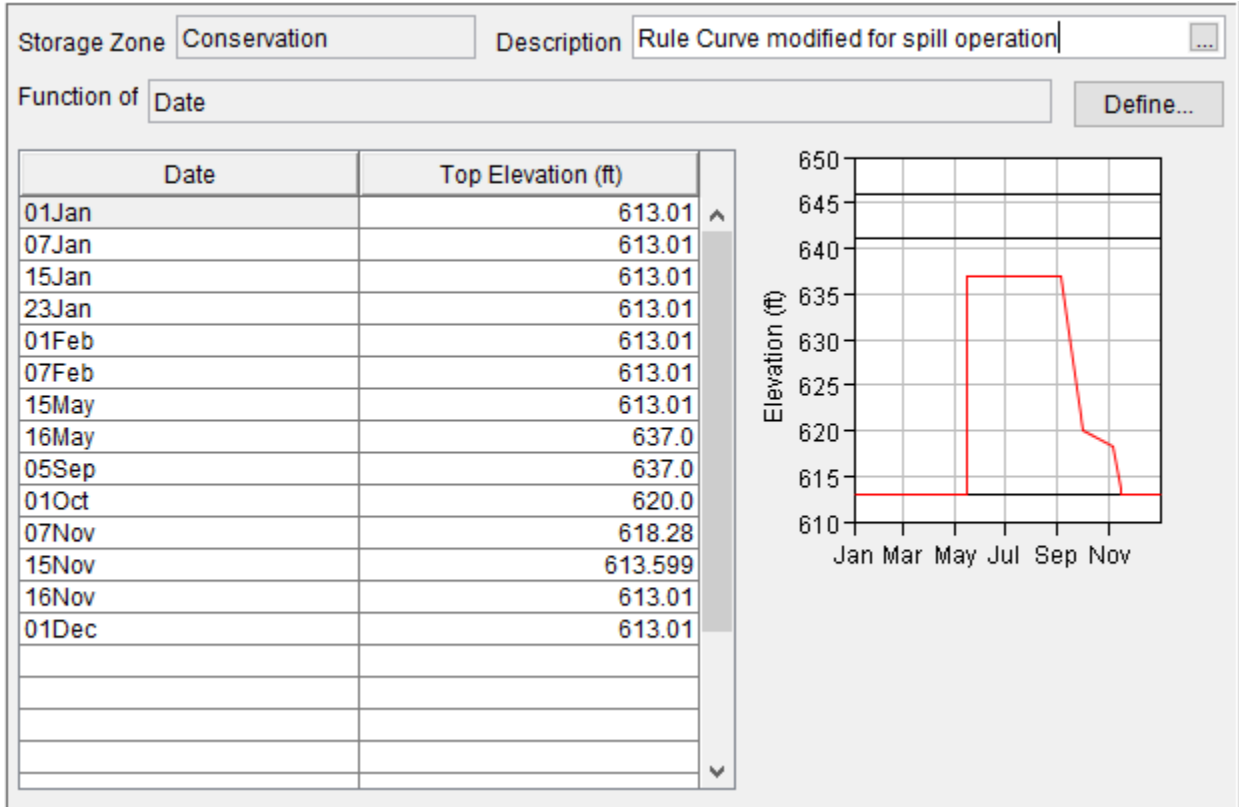

Figure 4-19. Foster Dam and Reservoir Interim Operations Target Elevation.

4.8.4 Cougar Dam and Reservoir

Delay refill targeting 1,520 feet between 01Feb and 15May, then target rule curve until initiating a fall drawdown beginning 01Jul targeting the 01Oct elevation on 01Sep, then targeting 1,505 feet from 15Nov to 15Dec. On 16Dec, target rule curve until following spring. Release flow through RO between 01Feb and 15May or whenever below 1,580 feet (Figure 4-20). Limit daily average releases during the spring delayed refill and fall drawdown to 2,000 cfs to reflect the average of night and day regulating outlet limitations to reduce TDG. Additionally, there is an 880 cfs release limit in September.

*Willamette Valley System Operations and Maintenance
Environmental Impact Statement*

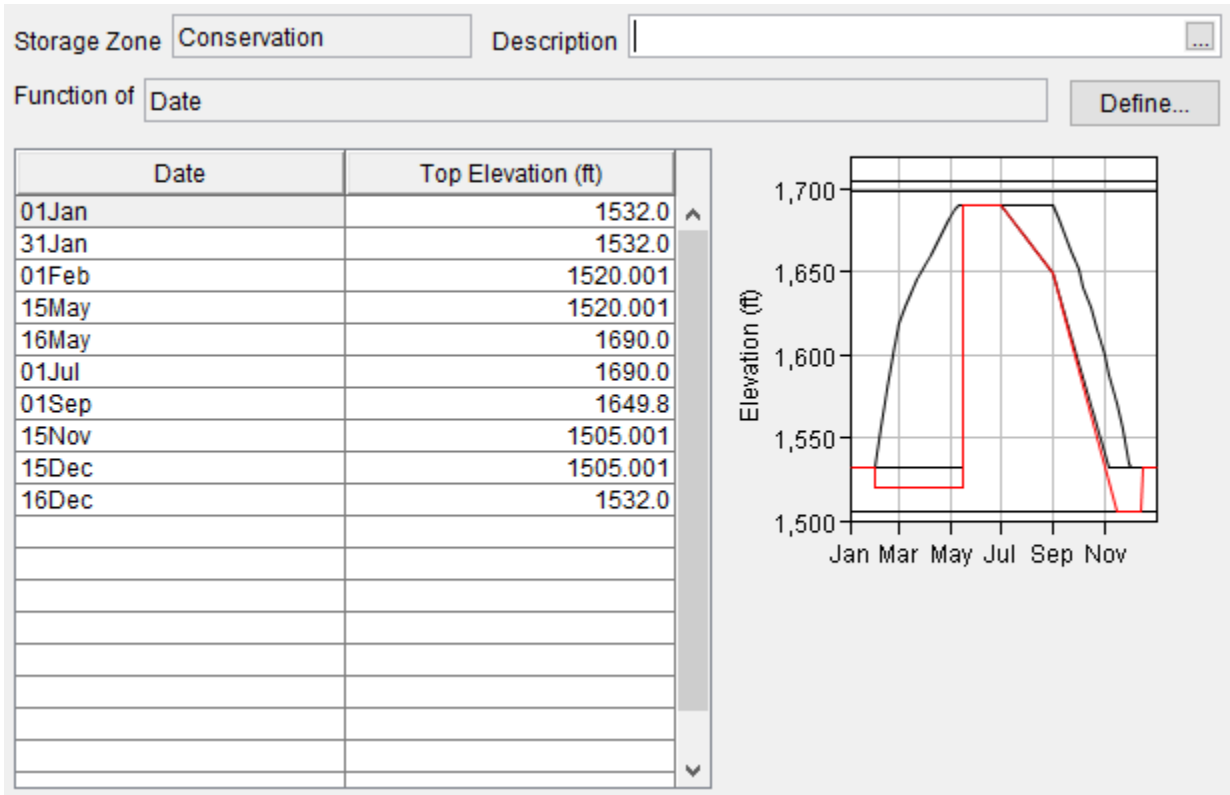

Figure 4-20. Cougar Spring and Fall Drawdown Target Elevation.

4.8.5 Hills Creek Dam and Reservoir

Release from Hills Creek Dam and Reservoir to promote filling at Lookout Point Dam and Reservoir in the spring by releasing 1,000 cfs instead of 400 cfs if Lookout Point Reservoir is below 95 percent full until May. Release 17 percent of flow through the regulating outlet when the reservoir is within 50 feet of the regulating outlet 01Oct through 01Mar. Penstock maximum restrictions may result in higher regulating outlet releases, and all flow will be released through the regulating outlet if Hills Creek Dam and Reservoir drafts below the minimum power pool. Hills Creek Dam and Reservoir will draft during the winter to provide minimum flow requirements below Lookout Point Dam and Reservoir.

4.8.6 Lookout Point Dam and Reservoir

Prioritize refill at Lookout Point Dam and Reservoir using released storage from Hills Creek Dam and Reservoir. Fill according to the rule curve until reaching 893 feet, then target 893 feet until 19Apr, then permit refill to the rule curve until reaching the drawdown target elevation which drafts from 896 feet on 01Jul to 750 feet on 15Nov. Target 761 feet from 15Nov to 15Dec. After 15Dec, target the rule curve until the following spring (Figure 4-21). Once above 893 feet in the spring, release all flow over the spillway until 01May and 60 percent of the flow over the spillway until 31May. Release 60 percent of the flow through the regulating outlet after 15Jul until reaching the minimum power pool, after which all flow will go through the regulating outlet.

*Willamette Valley System Operations and Maintenance
Environmental Impact Statement*

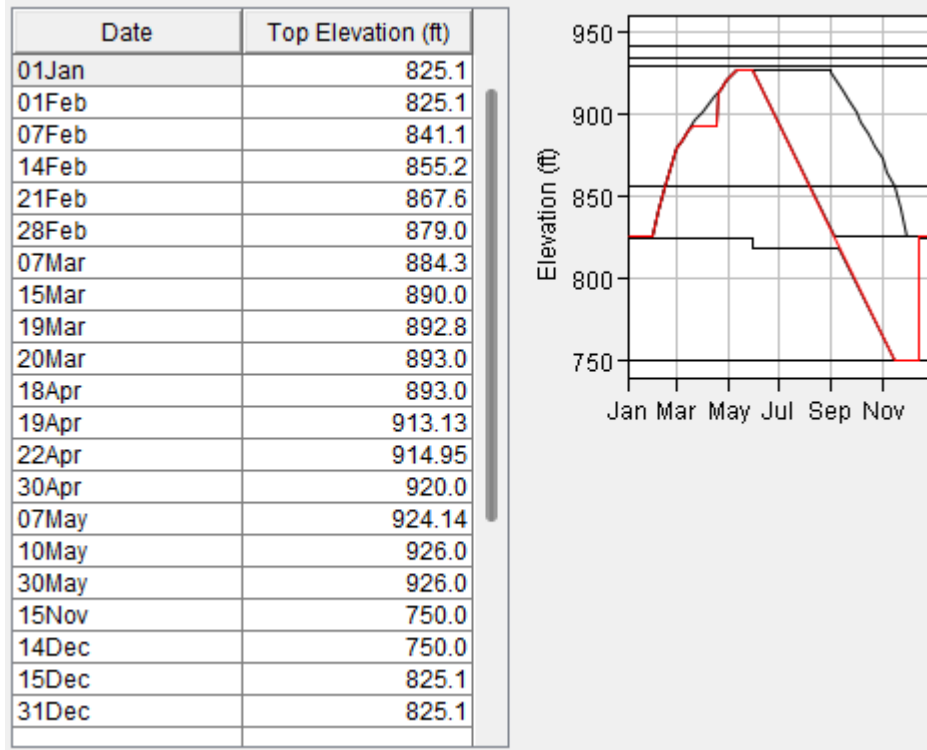

Figure 4-21. Lookout Point Interim Operations Target Elevation.

4.8.7 Dexter Dam and Reservoir

Release all flow over spillway when fish spill is happening at Lookout Point Dam and Reservoir.

4.8.8 Fall Creek Dam and Reservoir

There is no specific Interim Operation at Fall Creek Reservoir; therefore, model parameters are the same as those described for the NAA.

4.9 Modeling Discrepancies

4.9.1 Measure 30 Temperature Flows at Salem

Measure 30 temp flow at Salem is formulated to be a function of 7-day average daily high temperature at Salem. The HEC-ResSim model is formulated to accept this input and produce the minimum flow requirements based on temperature. However, the input supplied to the HEC-ResSim model (in the Temp_Min_Flows.dss file) does not appear to be temperature. It appears to be pre-calculated flow targets that vary abruptly from 0 cfs to many thousands of cfs. HEC-ResSim interprets this as “temperature,” which makes it think that either the temperature is very cold or very hot, using the very lowest target or the very highest target in the table, with nothing in between.

Alternative 5 was re-run with the M30 temperature rule corrected. Results show that the original rule calls on HEC-ResSim to release slightly more water than the corrected rule in time frames when the rule controls for minimum flow. However, the system as modeled has limited capacity to spike flows at Salem in response to the M30 temperature rule in both instances and the difference in realized flows is very small (Figure 4-22). Correcting the rule would not increase or diminish the original valuation of individual alternatives or the ranking of alternatives.

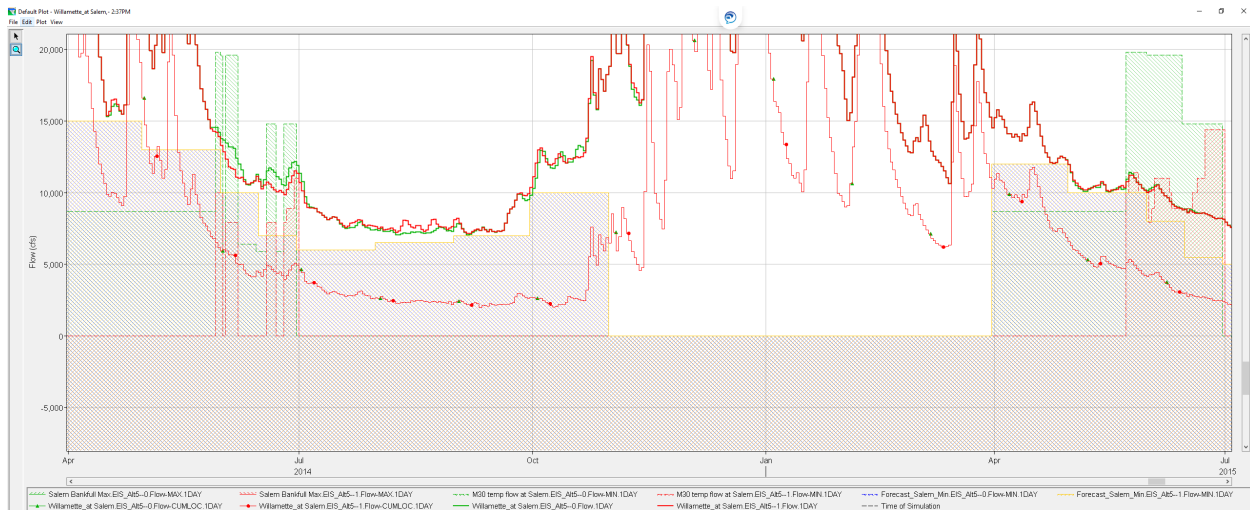

Figure 4-22. M30 Temp Flow Adherence at Salem – Red = fixed temp minimum target and flow, Green = Original temp minimum target and flow.

4.9.2 Measure 718

Dorena and Cottage Grove Dams and Reservoirs were permitted to draw down into the inactive pool in Alternatives 1, 3A, and 3B. Results in these alternatives showed that the reservoirs never significantly drafted into the inactive zone to meet minimum flow requirements but would draft into the inactive pool after normal conservation season drawdown which is not the intent of the measure. This operation was removed from Alternatives 2 and 5.

4.9.3 Measure 304

For all alternatives that implement Measure 304 at Hills Creek Dam and Reservoir (use the Power Pool to augment flows), the HEC-ResSim project releases increase when the pool elevation drops below min conservation (1,448 feet) in the summer in some years (like June 1992). This causes Hills Creek Dam and Reservoir to draft more quickly and reach the bottom of the power pool relatively rapidly. This behavior is because the “Max Con” rule is present only in the Conservation zone, and not in the Buffer zone in HEC-ResSim. In reality, releases from Hills Creek Dam and Reservoir would likely taper off as the pool dropped, not increase. As a result, Hills Creek Dam and Reservoir is unable to maintain a minimum release of 400 cfs later in the summer.

4.9.4 Measure 40

The max spawning flow of 3,000 cfs from 01Sep–15Oct downstream of Foster Dam and Reservoir is applied in the NAA in HEC-ResSim as a rule at Foster Dam and Reservoir. It works well for the NAA, but in alternatives where there is a deep fall drawdown at Green Peter Dam and Reservoir (Alternatives 2A, 2B, 3A, 3B, 5) it produces unexpected results. Often, the increased releases from Green Peter Dam and Reservoir make it difficult for Foster Dam and Reservoir to maintain 3,000 cfs. A maximum release of 2,825 cfs is applied at Green Peter Dam and Reservoir in the model, assuming that flows from the South Santiam above Foster Dam and Reservoir would contribute 175 cfs to generate 3,000 cfs total. When flows are higher than this, the releases from Green Peter Dam and Reservoir would need to be cut back. This would likely be implemented in real-time operations, but this logic is not incorporated into the HEC-ResSim model, leading to the results at Foster Dam and Reservoir. As a result, it attempts to maintain 3,000 cfs, which causes the pool to rise into the flood control zone, which then results in some oscillating releases.

4.9.5 Measure 392 and 479

Alternatives 2A, 2B, and 5 do not add the Measure 479 warm water conduit diversion of 144 cfs in May and 72 cfs in June to the Measure 392 spillway flow requirement of 600 cfs, which is inconsistent with how the measures were modeled together in Alternatives 1 and 4.

The measure description for Measure 392 states that “The design would utilize a flow rate of 500–800 cfs (over the spillway). For modeling, a 600 cfs flow will be assumed.” The minimum tributary flow below Foster Dam and Reservoir in Alternatives 2A, 2B, and 5 requires a minimum of 770 to 1,550 cfs in May and 910 to 1,550 cfs in June, depending on whether Green Peter Dam and Reservoir is greater than or less than 90 percent full. Therefore, the total flow out of Foster Dam and Reservoir is adequate for the operation and only a small discrepancy in the allocation of flow between the spillway and power plant results from the omission.

4.9.6 3 Feet/day Draft Limit Below Minimum Conservation Elevation

A rule limiting the draft rate to 3ft/day or less when below the normal minimum conservation elevation was not applied at Cougar Dam and Reservoir in Alternative 3A, permitting the reservoir to draft faster than desired between 1,532 feet and 1,517 feet during the fall and spring drawdowns.

4.9.7 Cougar Penstock Release at or Below 1,520 Feet

ResSim underestimates the maximum powerhouse capacity at and below elevation 1,520 feet, the spring delayed refill elevation in the Interim Operations. The power release is capped at approximately 80 cfs when at 1,520 feet when daily average penstock releases should be as much as 1,200 cfs when Cougar Dam and Reservoir is releasing the maximum daily average release of 2,000 cfs.

5 ALTERNATIVE NON-EXCEEDANCE PLOTS

Non-exceedance plots comparing modeled alternatives to the NAA are provided below. Non-exceedance plots show the probability that an elevation or flow does not exceed a given value on a given day. The colored lines indicate non-exceedance percentiles for the modeled alternative and the shaded regions indicate percentiles for the NAA. In example Figure 5-1, in 5 percent of years on May 1st, alternative elevations do not exceed 1,511 feet and NAA elevations do not exceed 1,494 feet. It is important to note that a line or shaded region on a plot does not represent a continuous year. The reservoir may have a relatively high elevation in the spring in the same year it has a relatively low elevation in the fall.

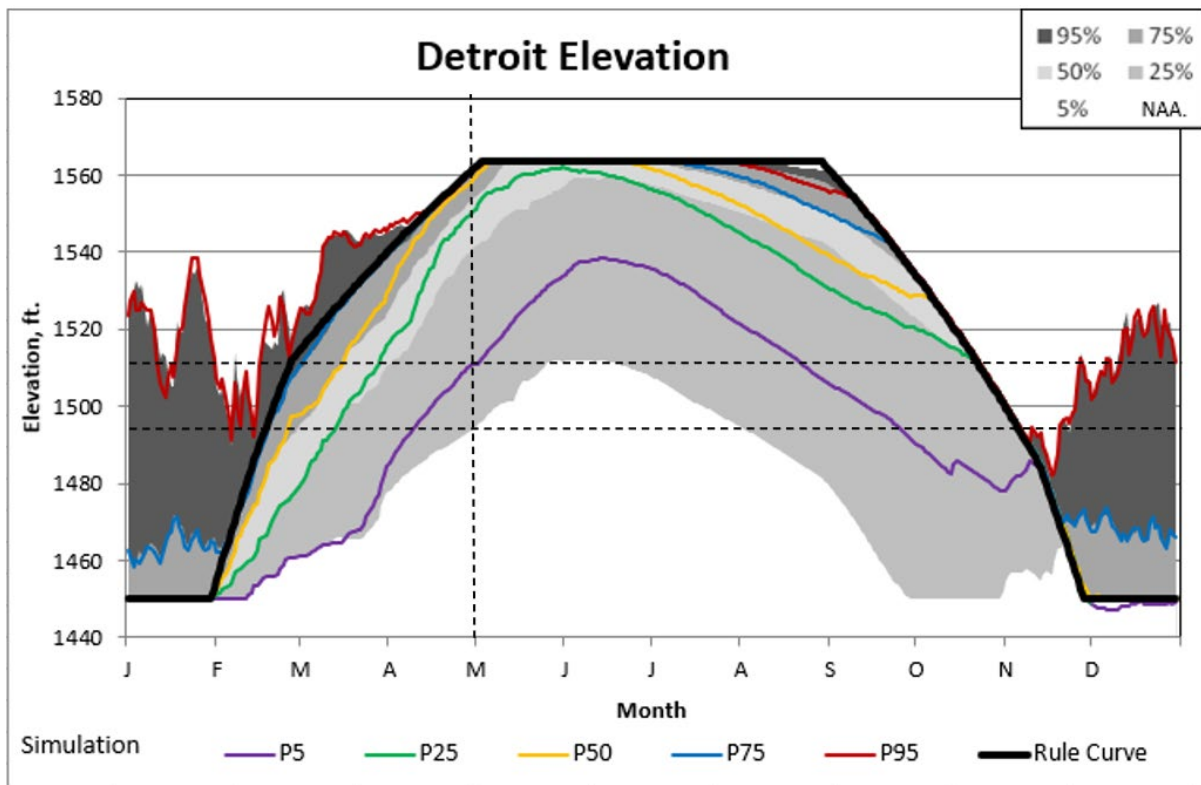

Figure 5-1. Example Non-exceedance Plot.

5.1 Alternative 1

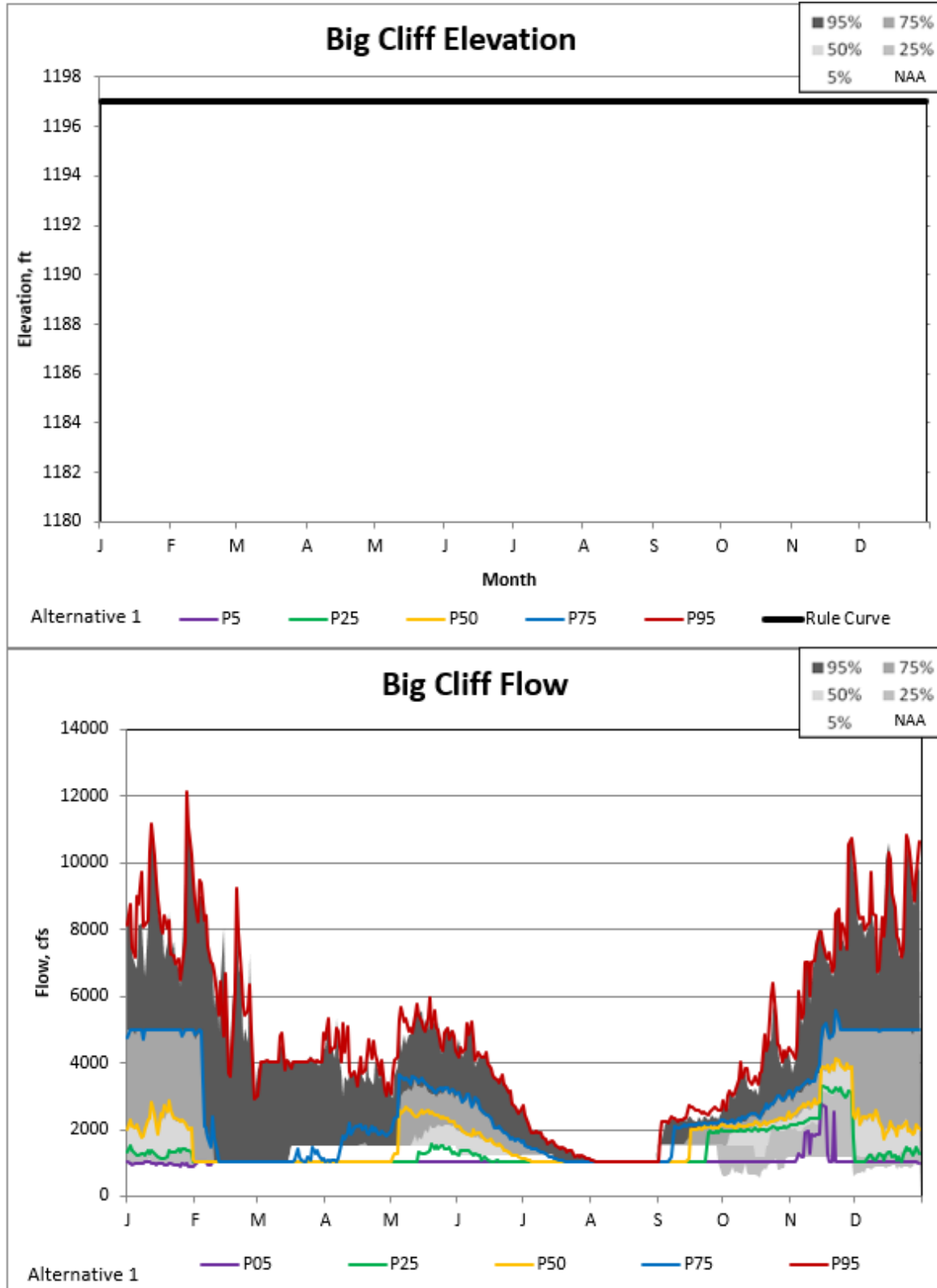

Figure 5-2. Big Cliff Alternative 1 Non-exceedance Plot.

Willamette Valley System Operations and Maintenance
Environmental Impact Statement

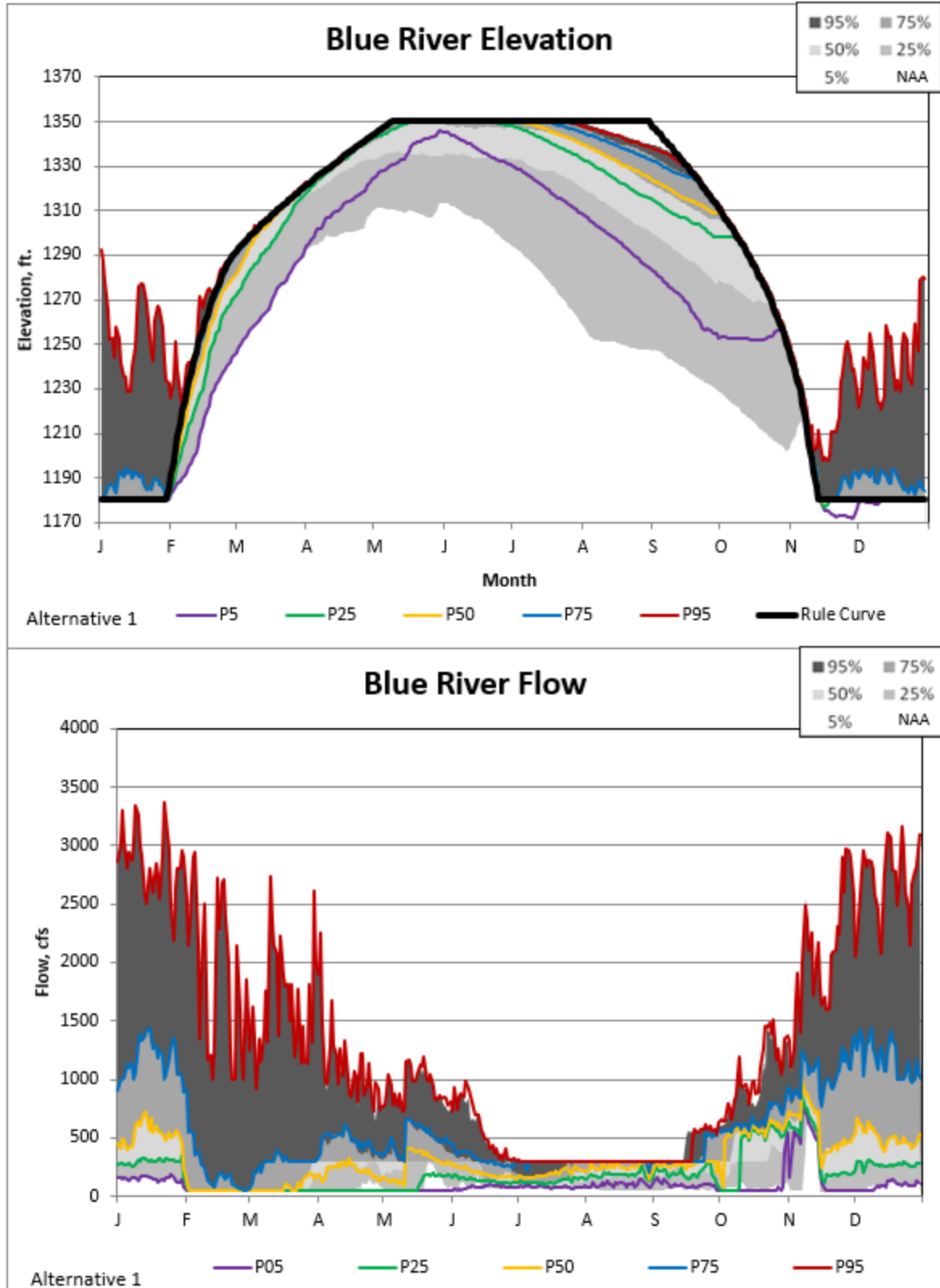

Figure 5-3. Blue River Alternative 1 Non-exceedance Plot.

Willamette Valley System Operations and Maintenance
Environmental Impact Statement

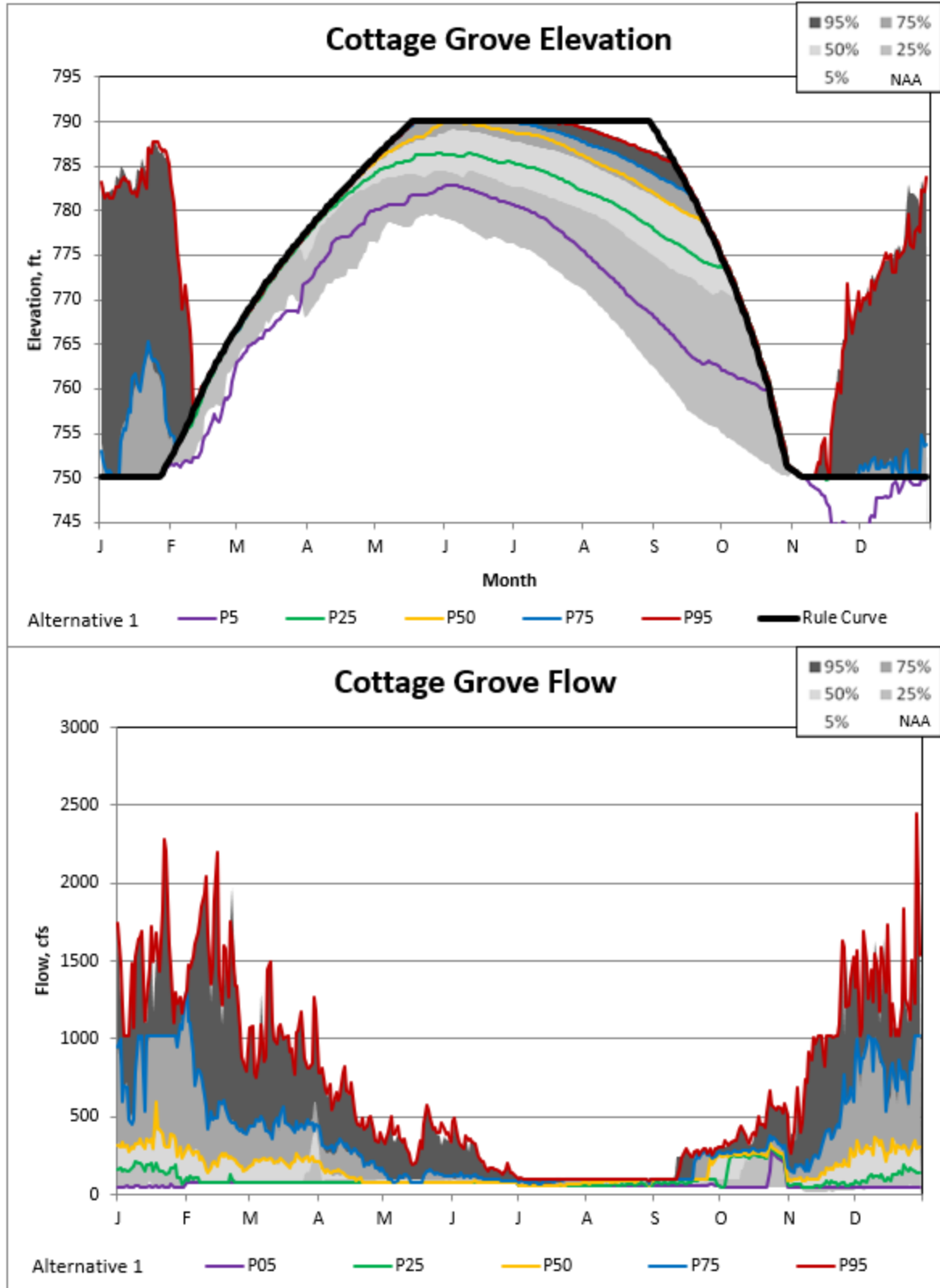

Figure 5-4. Cottage Grove Alternative 1 Non-exceedance Plot.

Willamette Valley System Operations and Maintenance
Environmental Impact Statement

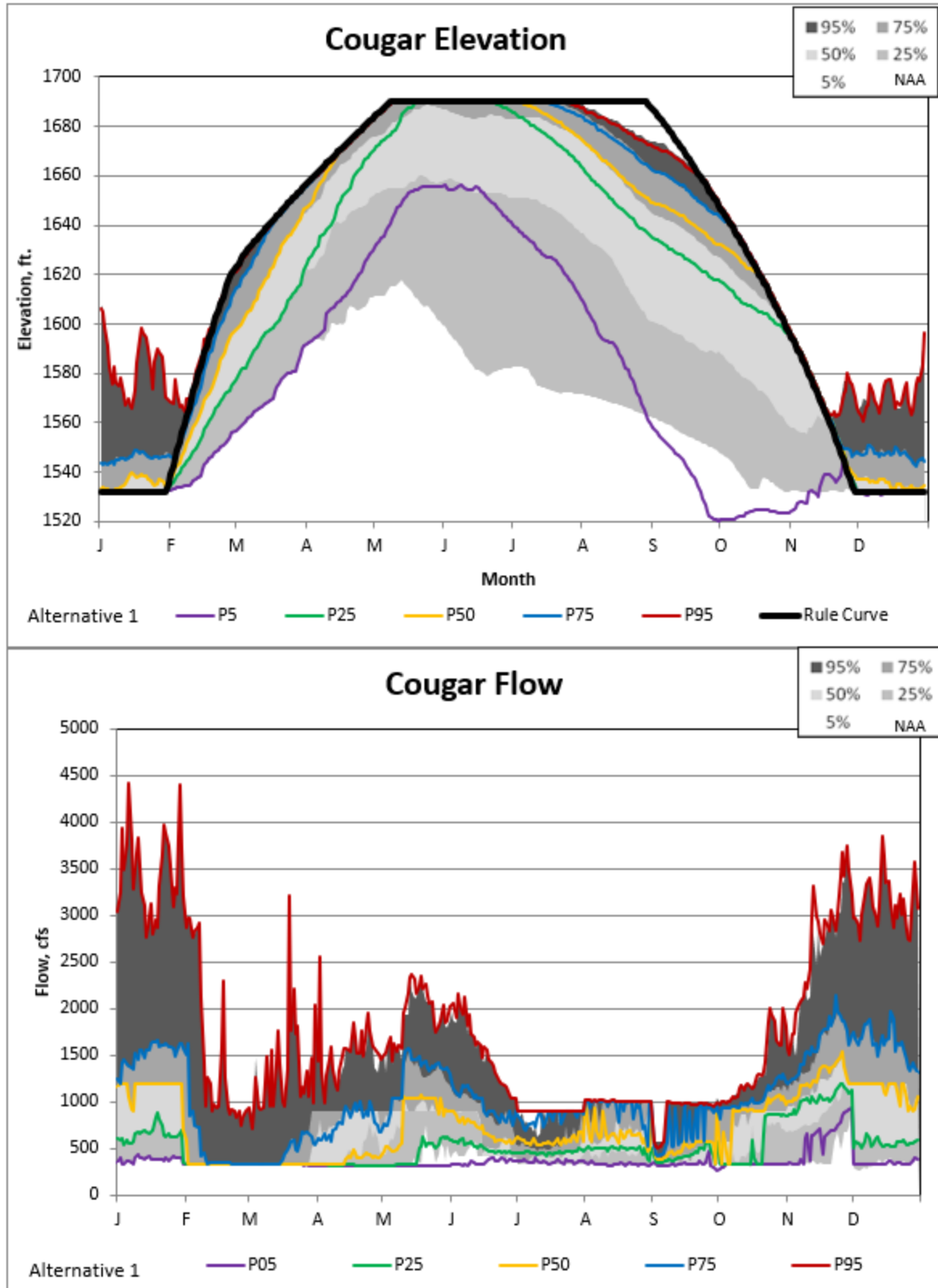

Figure 5-5. Cougar Alternative 1 Non-exceedance Plot.

Willamette Valley System Operations and Maintenance
Environmental Impact Statement

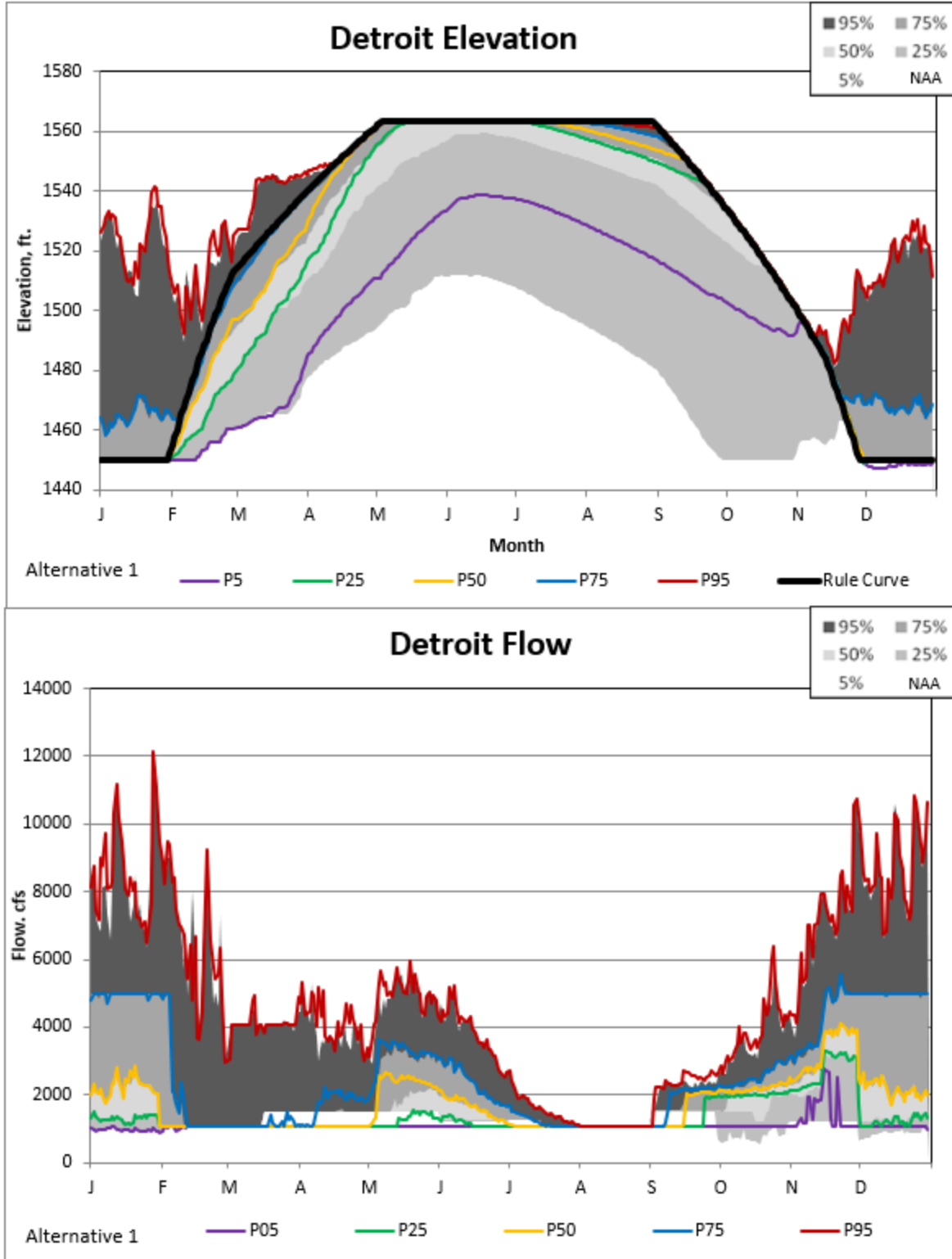

Figure 5-6. Detroit Alternative 1 Non-exceedance Plot.

Willamette Valley System Operations and Maintenance
Environmental Impact Statement

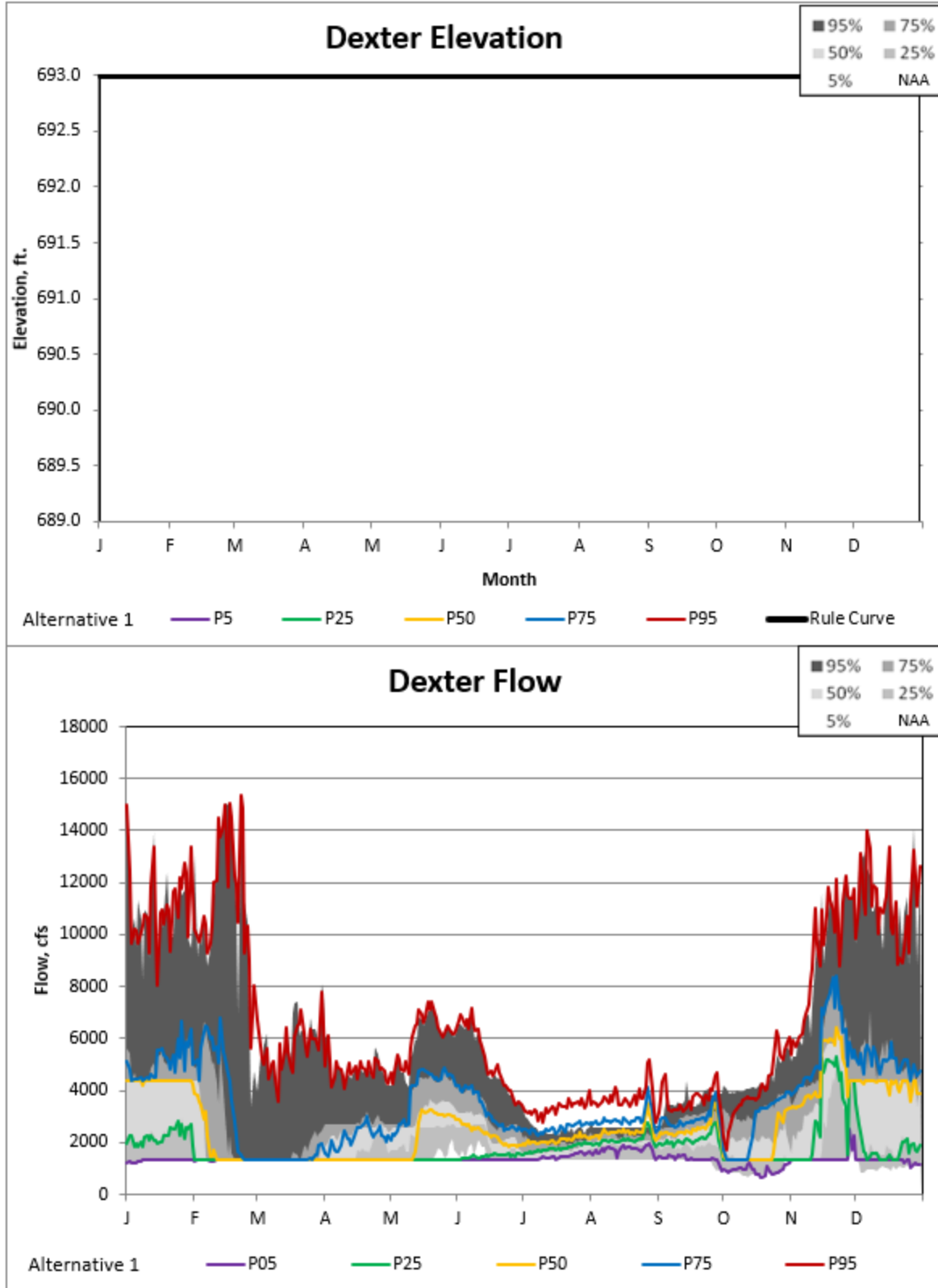

Figure 5-7. Dexter Alternative 1 Non-exceedance Plot.

Willamette Valley System Operations and Maintenance
Environmental Impact Statement

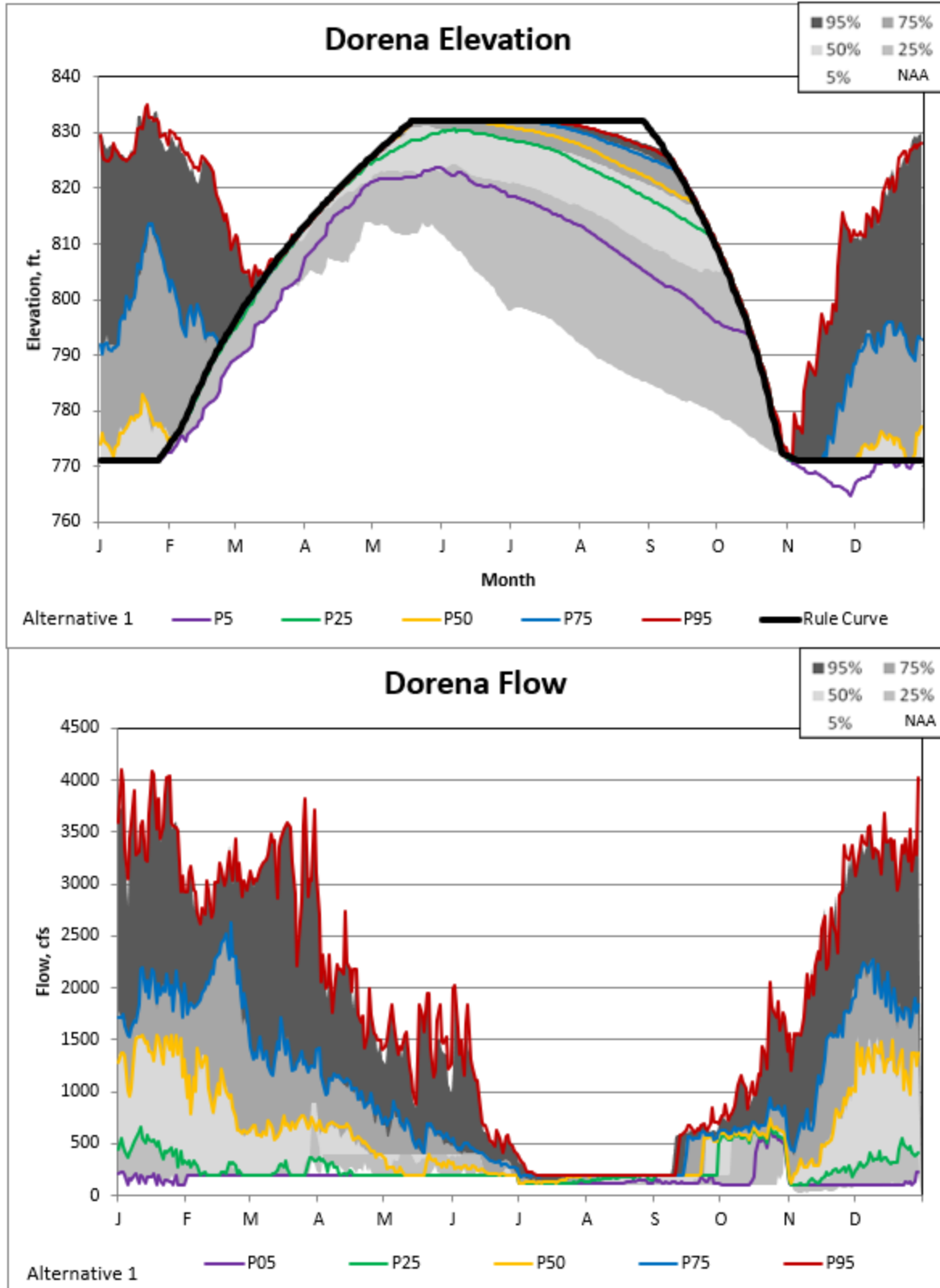

Figure 5-8. Dorena Alternative 1 Non-exceedance Plot.

Willamette Valley System Operations and Maintenance
Environmental Impact Statement

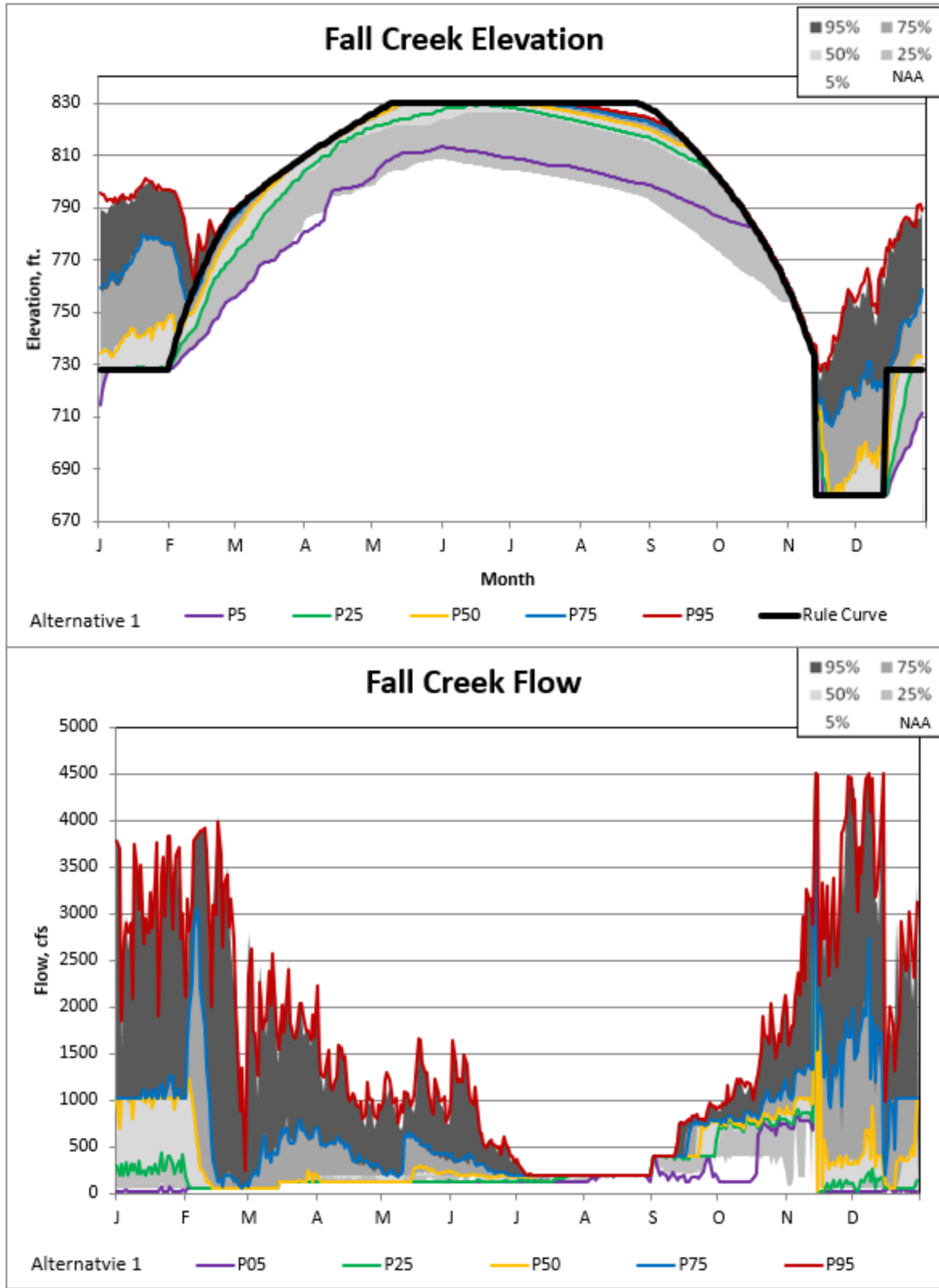

Figure 5-9. Fall Creek Alternative 1 Non-exceedance Plot.

Willamette Valley System Operations and Maintenance
Environmental Impact Statement

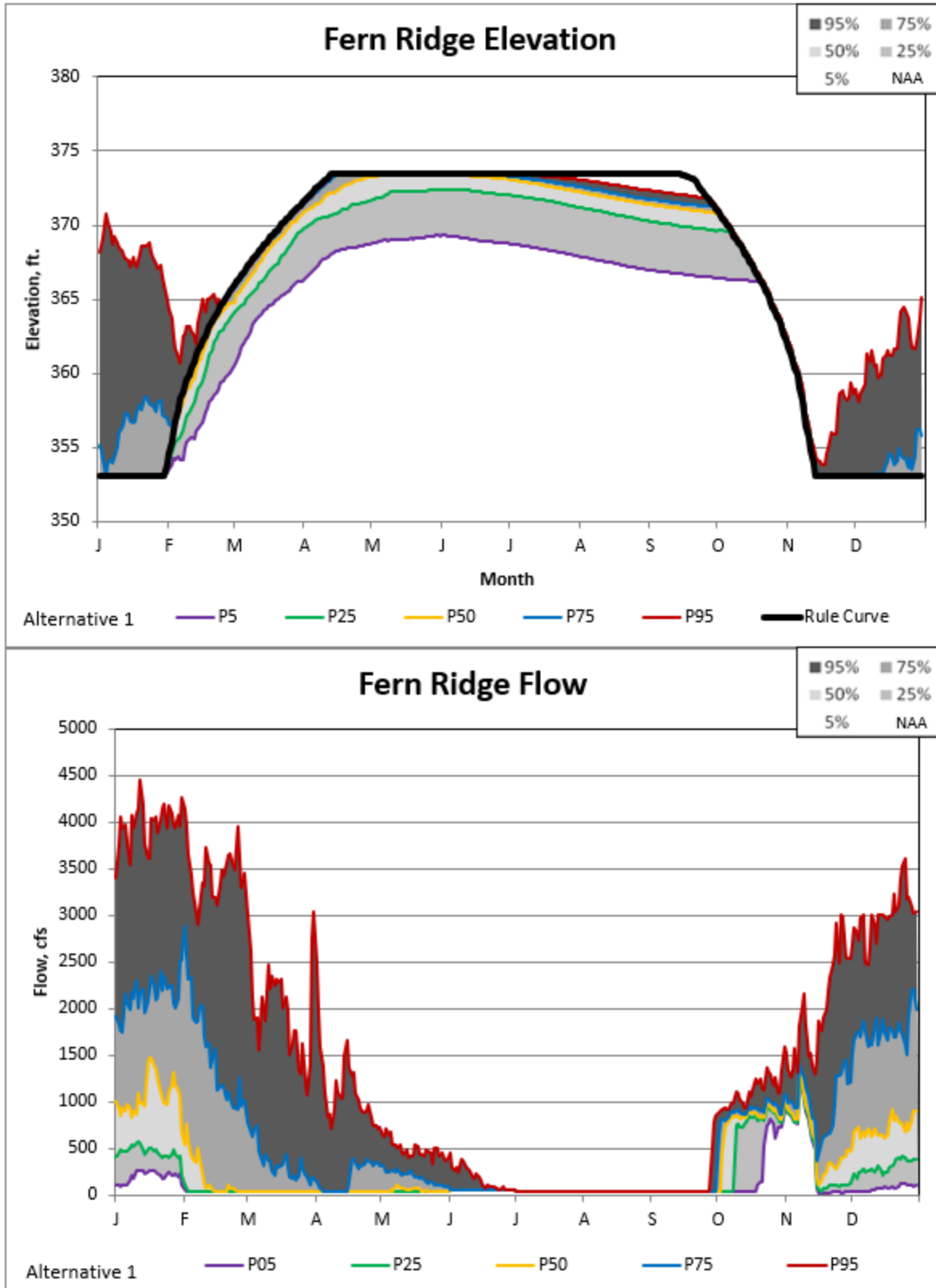

Figure 5-10. Fern Ridge Alternative 1 Non-exceedance Plot.

Willamette Valley System Operations and Maintenance
Environmental Impact Statement

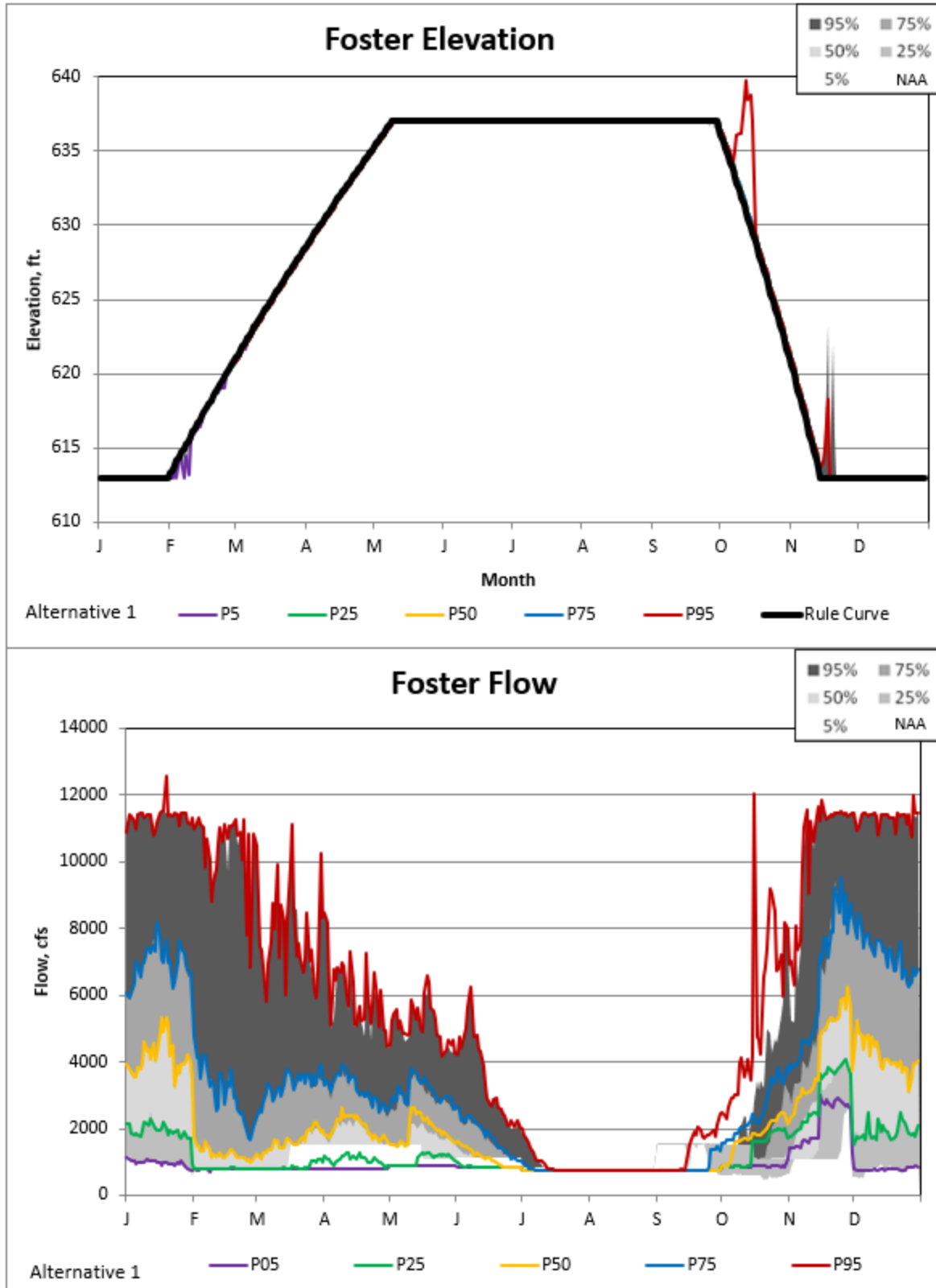

Figure 5-11. Foster Alternative 1 Non-exceedance Plot.

Willamette Valley System Operations and Maintenance
Environmental Impact Statement

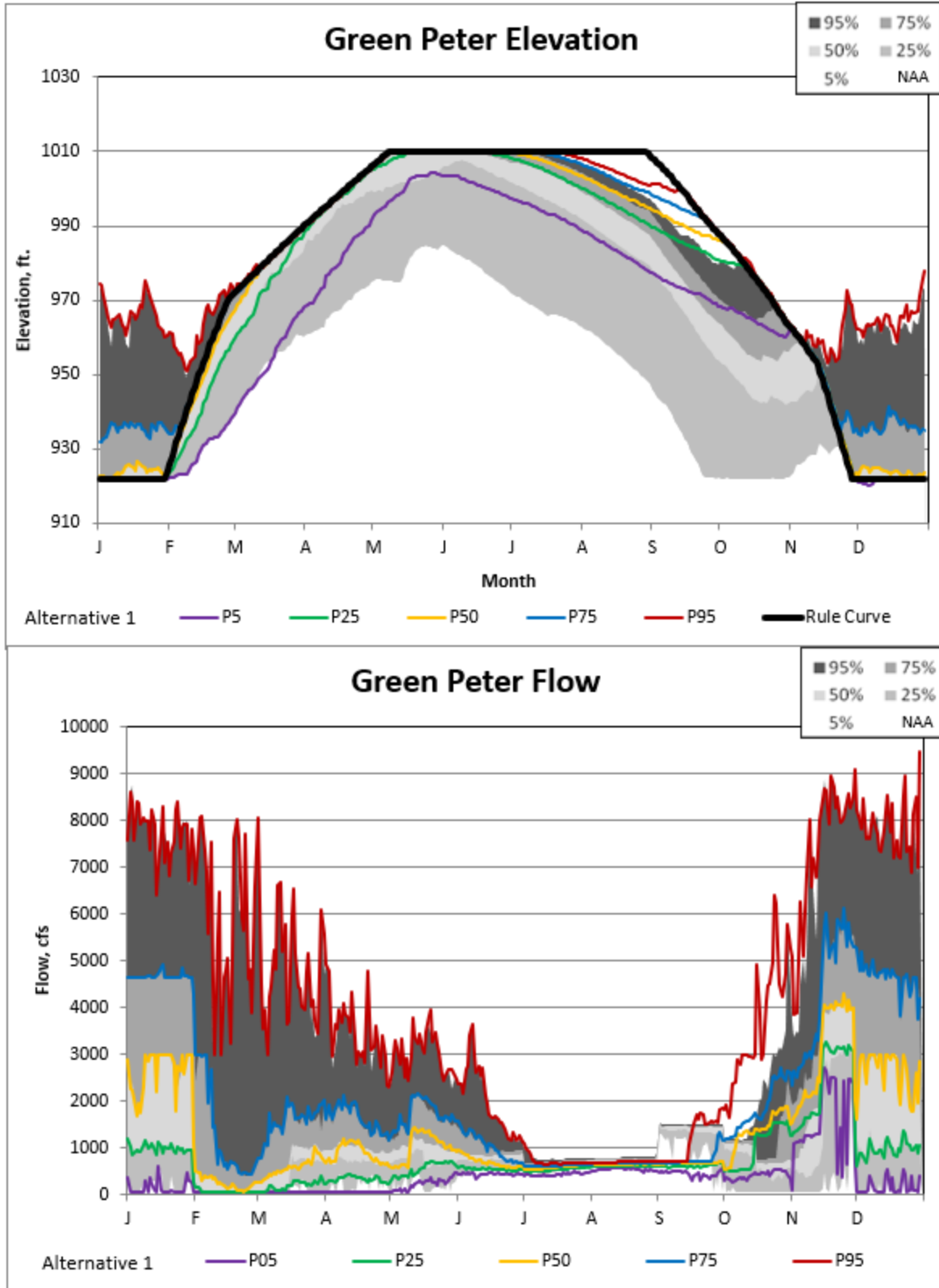

Figure 5-12. Green Peter Alternative 1 Non-exceedance Plot.

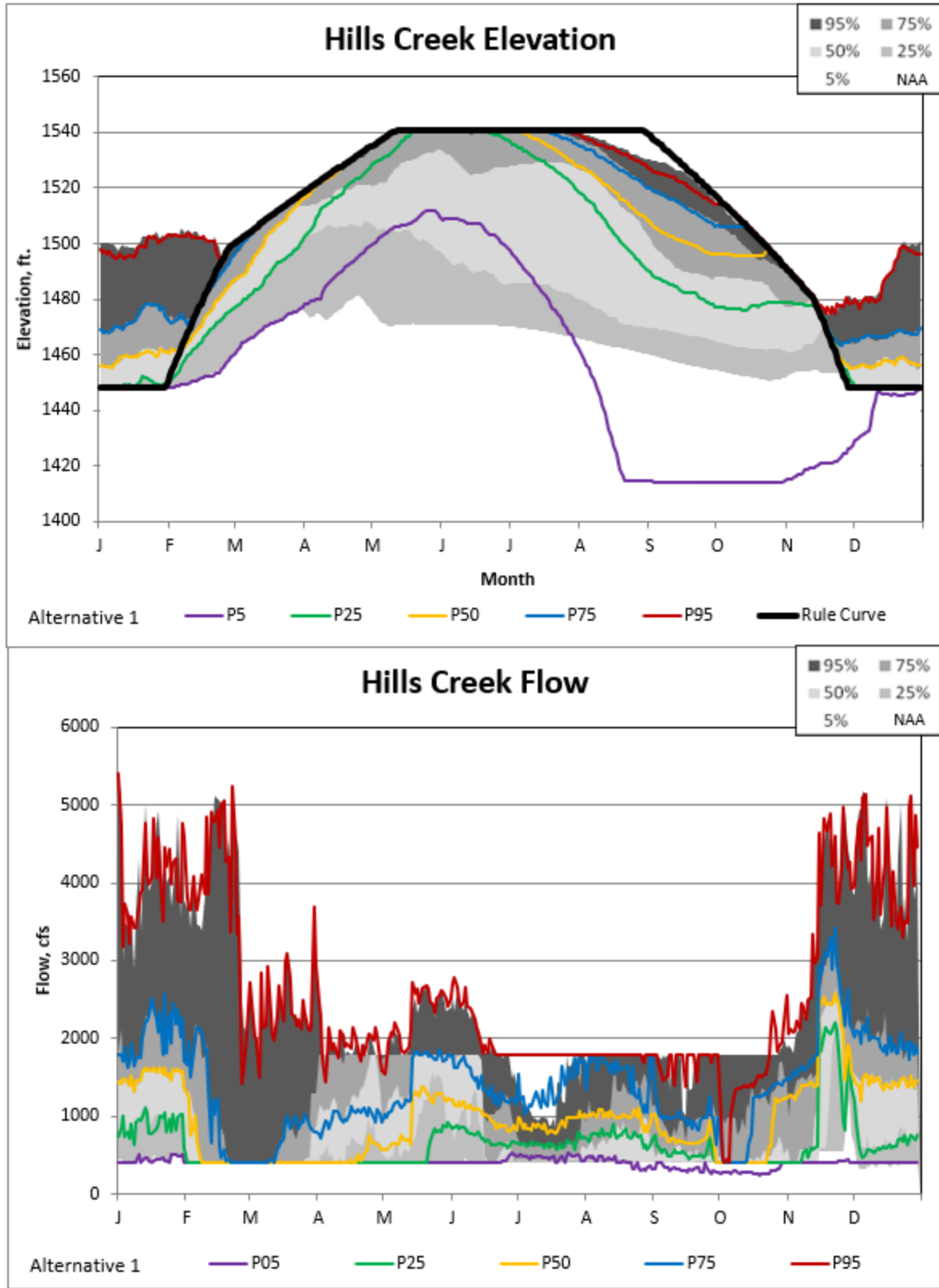

Figure 5-13. Hills Creek Alternative 1 Non-exceedance Plot.

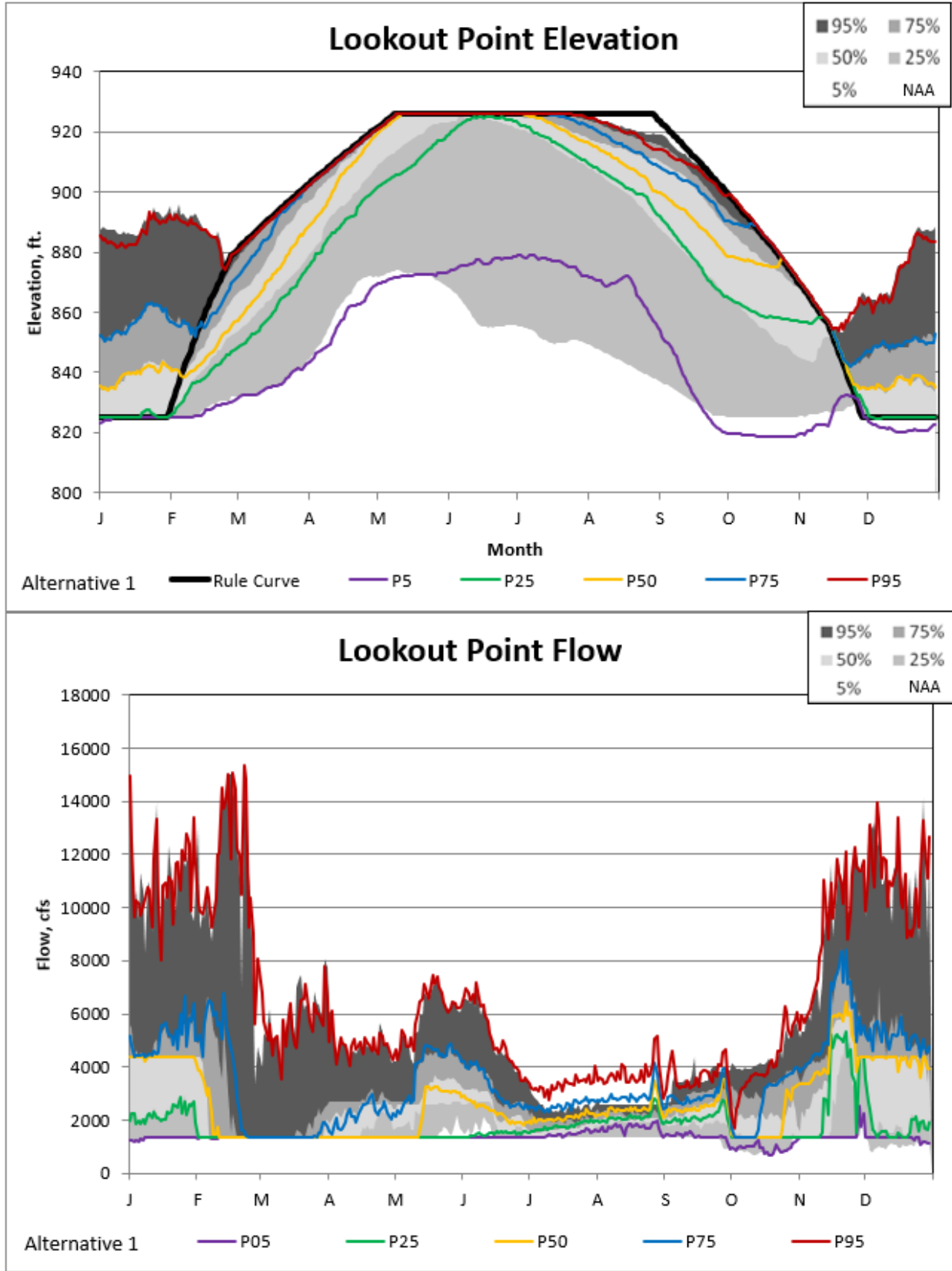

Figure 5-14. Lookout Point Alternative 1 Non-exceedance Plot.

*Willamette Valley System Operations and Maintenance
Environmental Impact Statement*

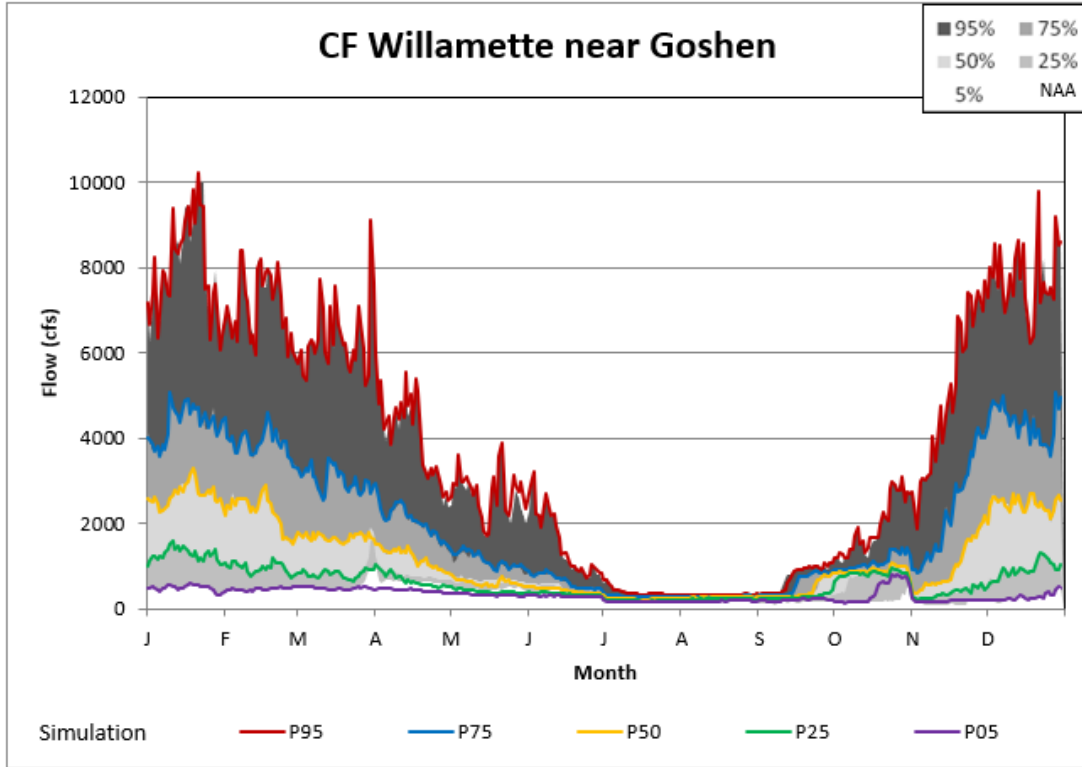

Figure-5-15. Goshen Alternative 1 Non-Exceedance Plot.

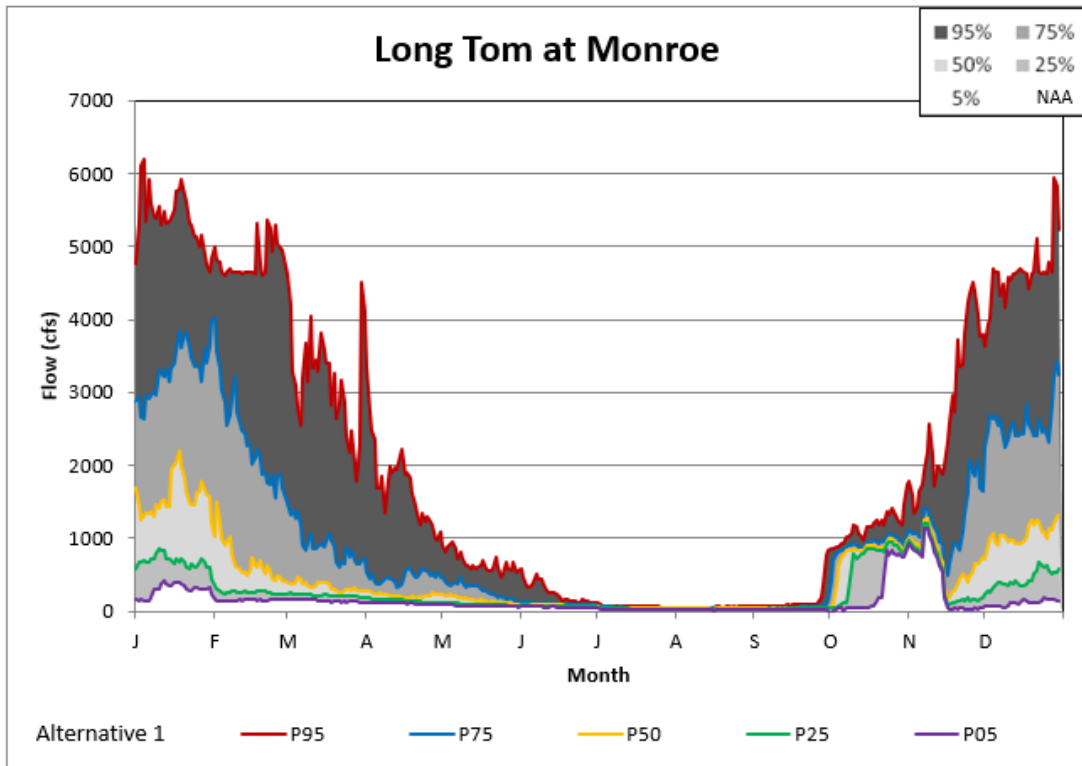

Figure 5-16. Monroe Alternative 1 Non-exceedance Plot.

Willamette Valley System Operations and Maintenance
Environmental Impact Statement

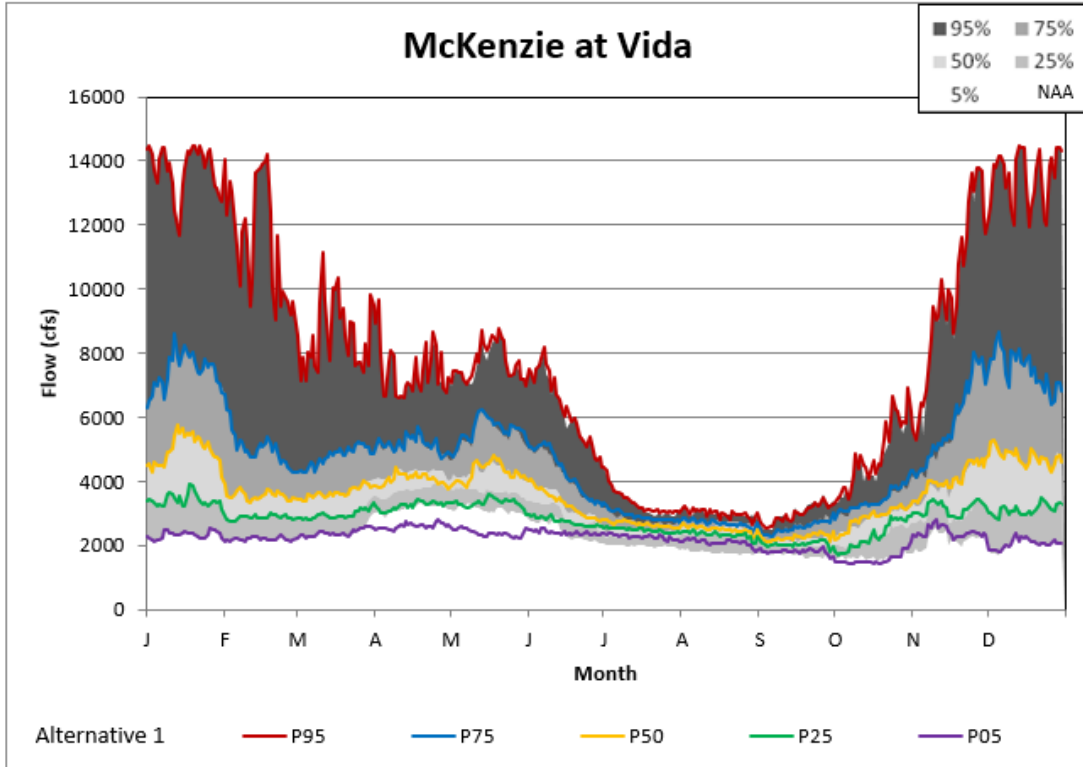

Figure 5-17. Vida Alternative 1 Non-exceedance Plot.

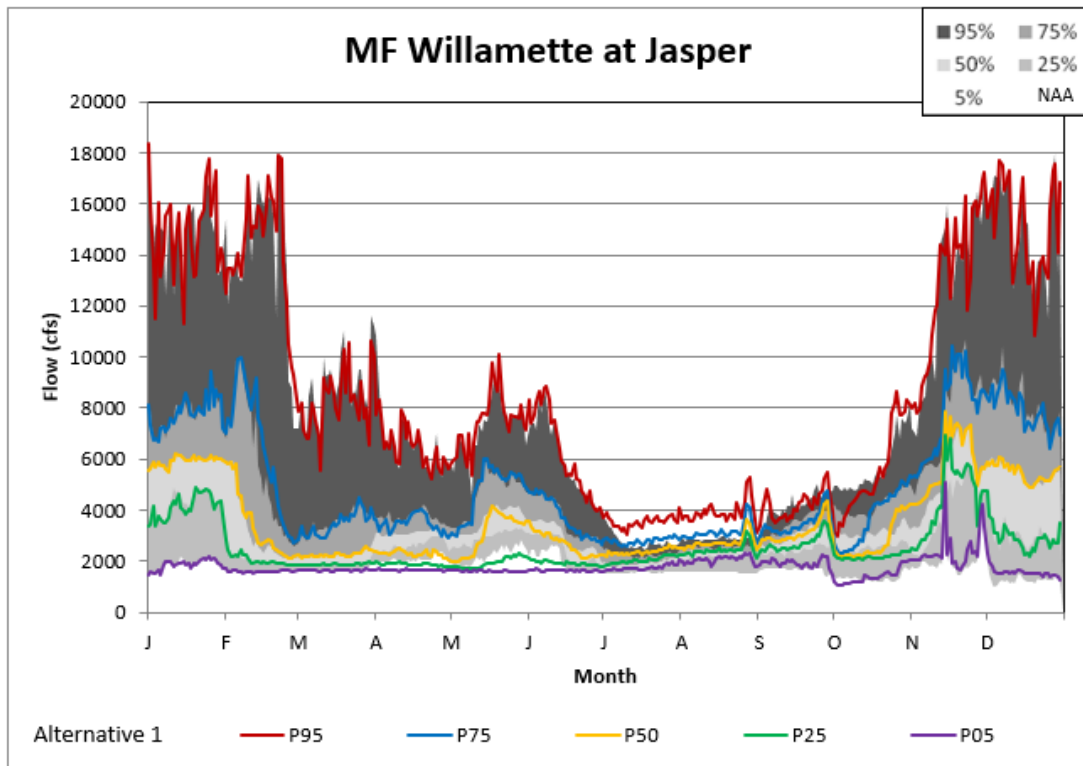

Figure 5-18. Jasper Alternative 1 Non-exceedance Plot.

Willamette Valley System Operations and Maintenance
Environmental Impact Statement

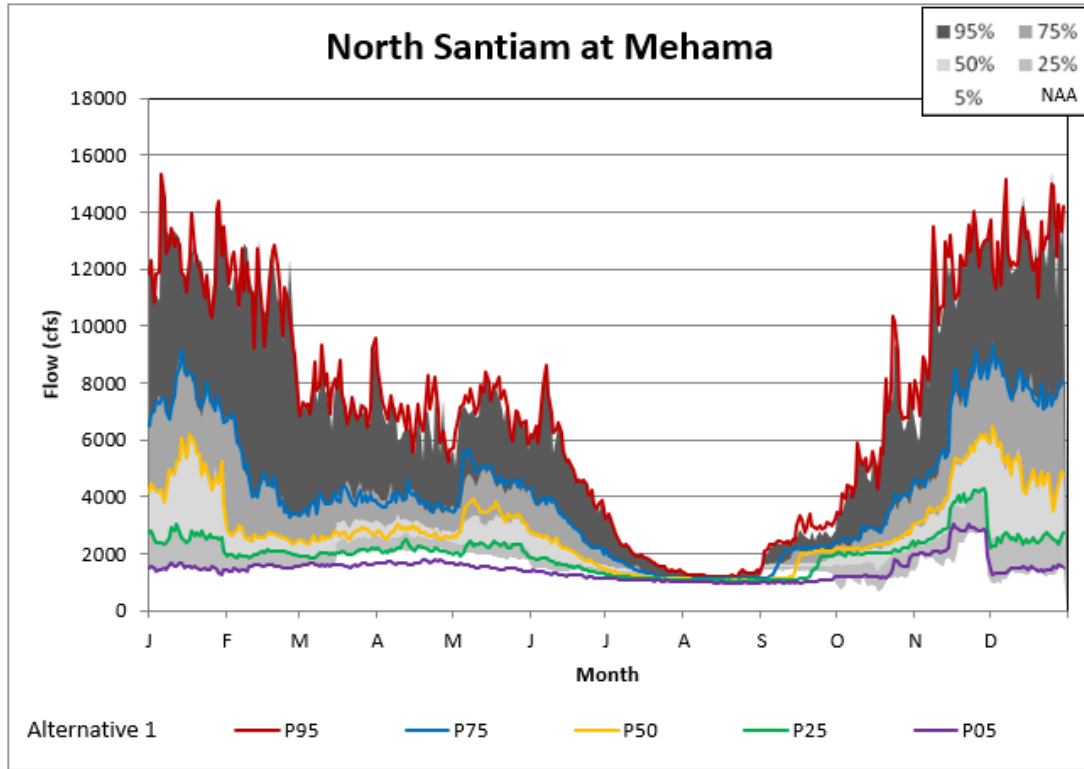

Figure 5-19. Mehama Alternative 1 Non-exceedance Plot.

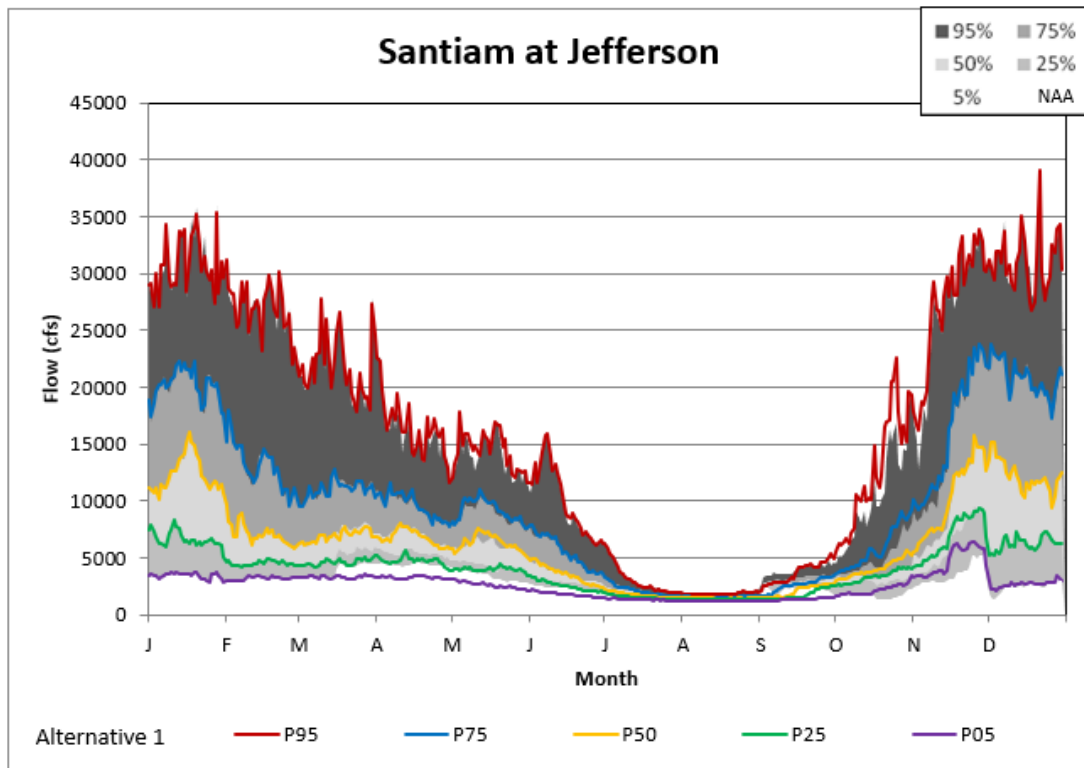

Figure 5-20. Jefferson Alternative 1 Non-exceedance Plot.

Willamette Valley System Operations and Maintenance
Environmental Impact Statement

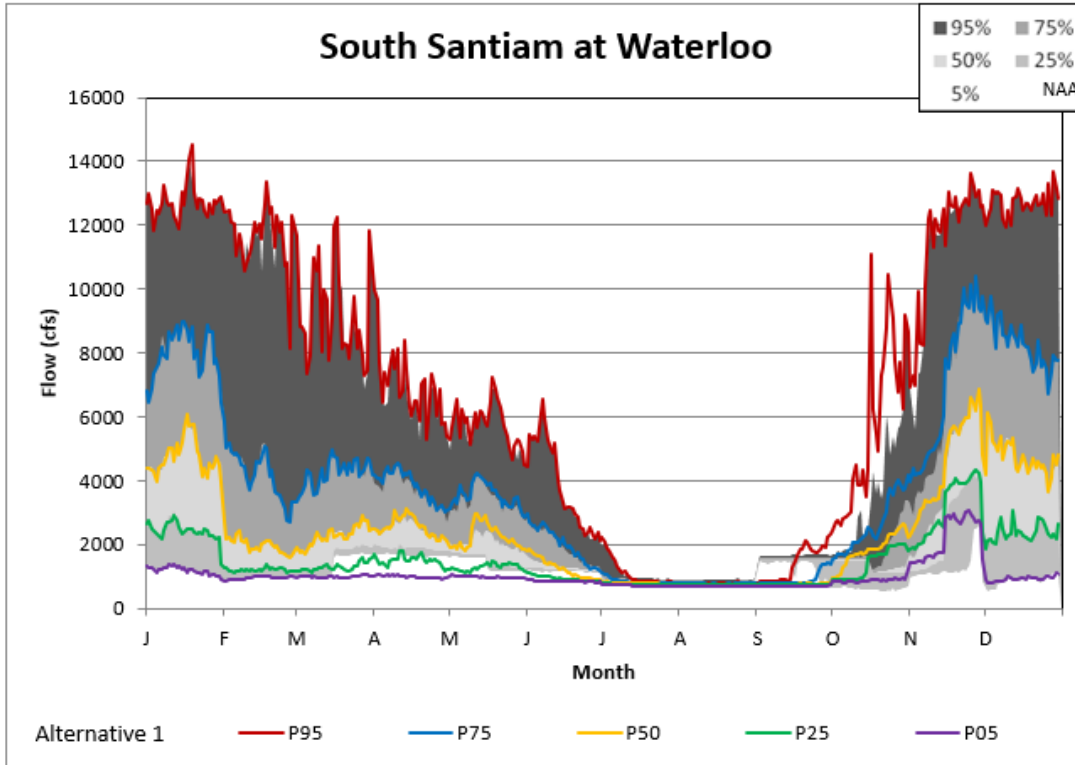

Figure 5-21. Waterloo Alternative 1 Non-exceedance Plot.

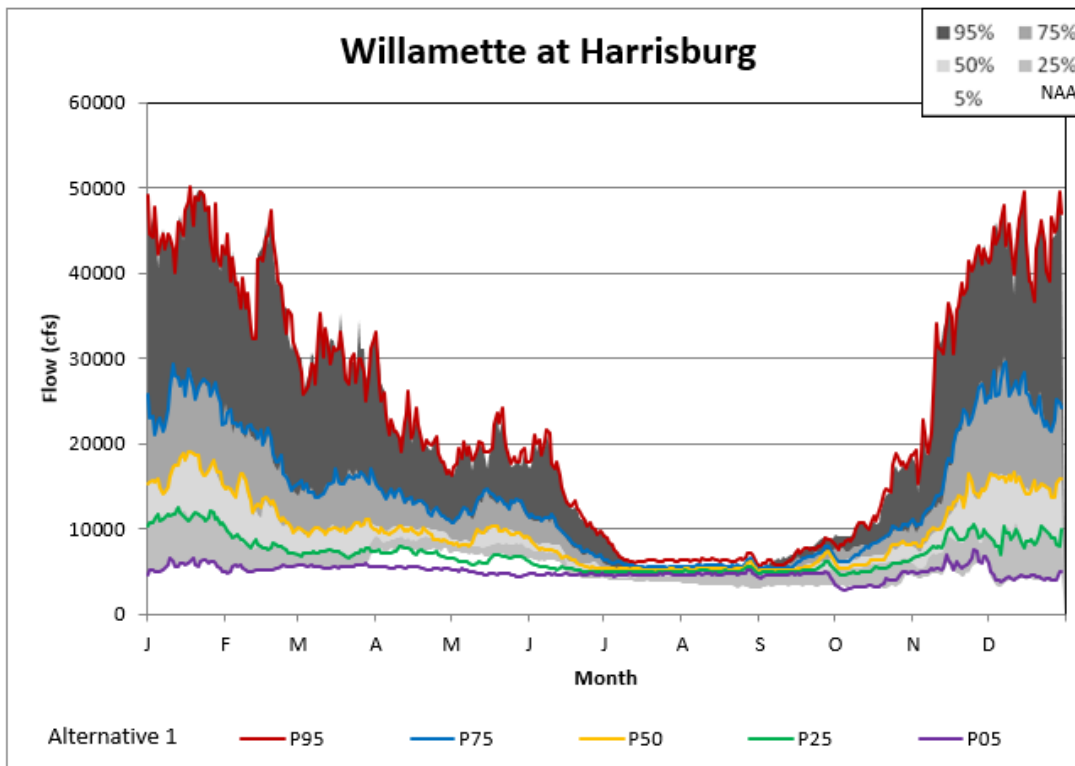

Figure 5-22. Harrisburg Alternative 1 Non-exceedance Plot.

Willamette Valley System Operations and Maintenance
Environmental Impact Statement

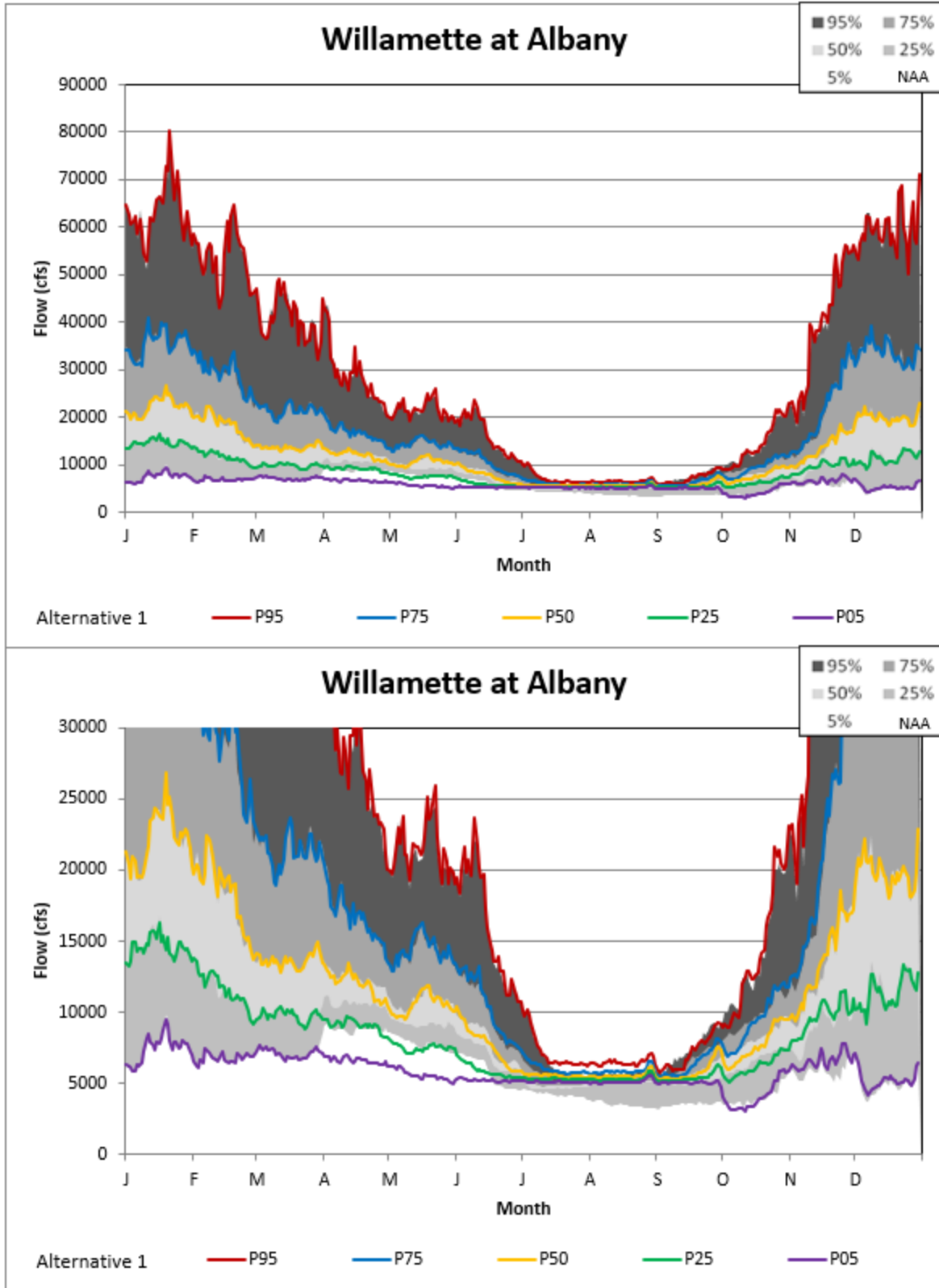

Figure 5-23. Albany Alternative 1 Non-exceedance Plot.

Willamette Valley System Operations and Maintenance
Environmental Impact Statement

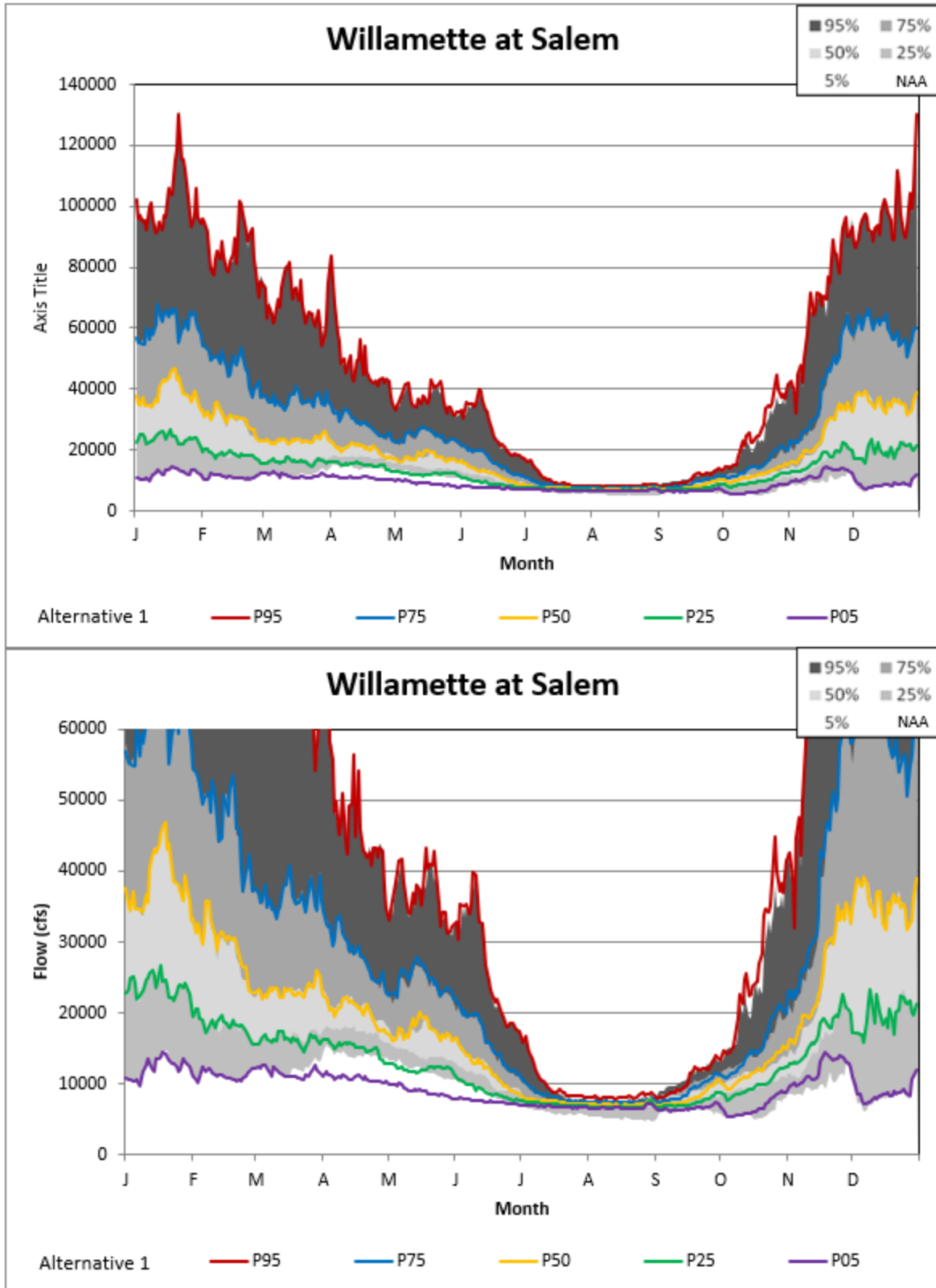

Figure 5-24. Salem Alternative 1 Non-exceedance Plot.

5.2 Alternative 2A

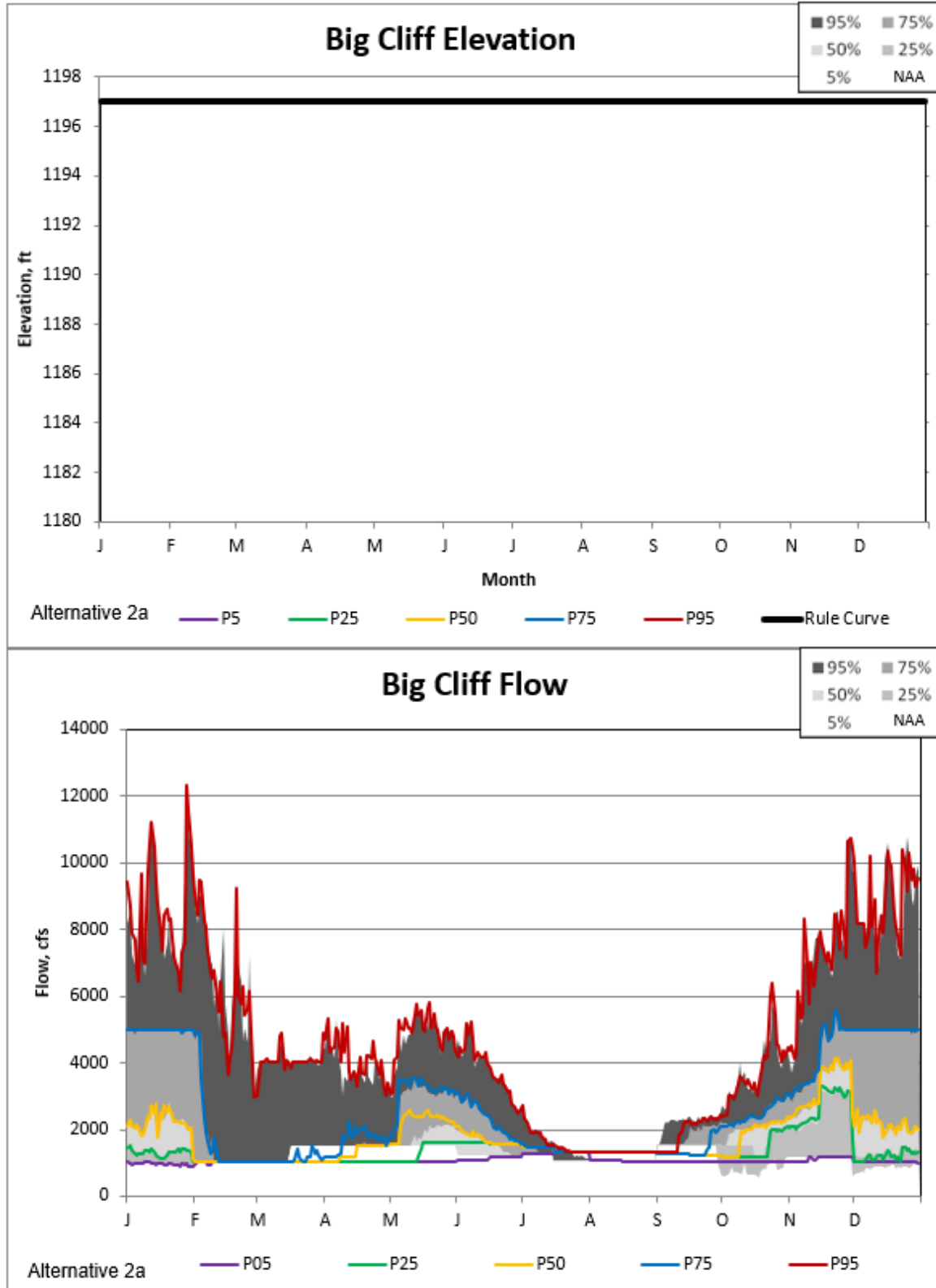

Figure 5-25. Big Cliff Alternative 2A Non-exceedance Plot.

Willamette Valley System Operations and Maintenance
Environmental Impact Statement

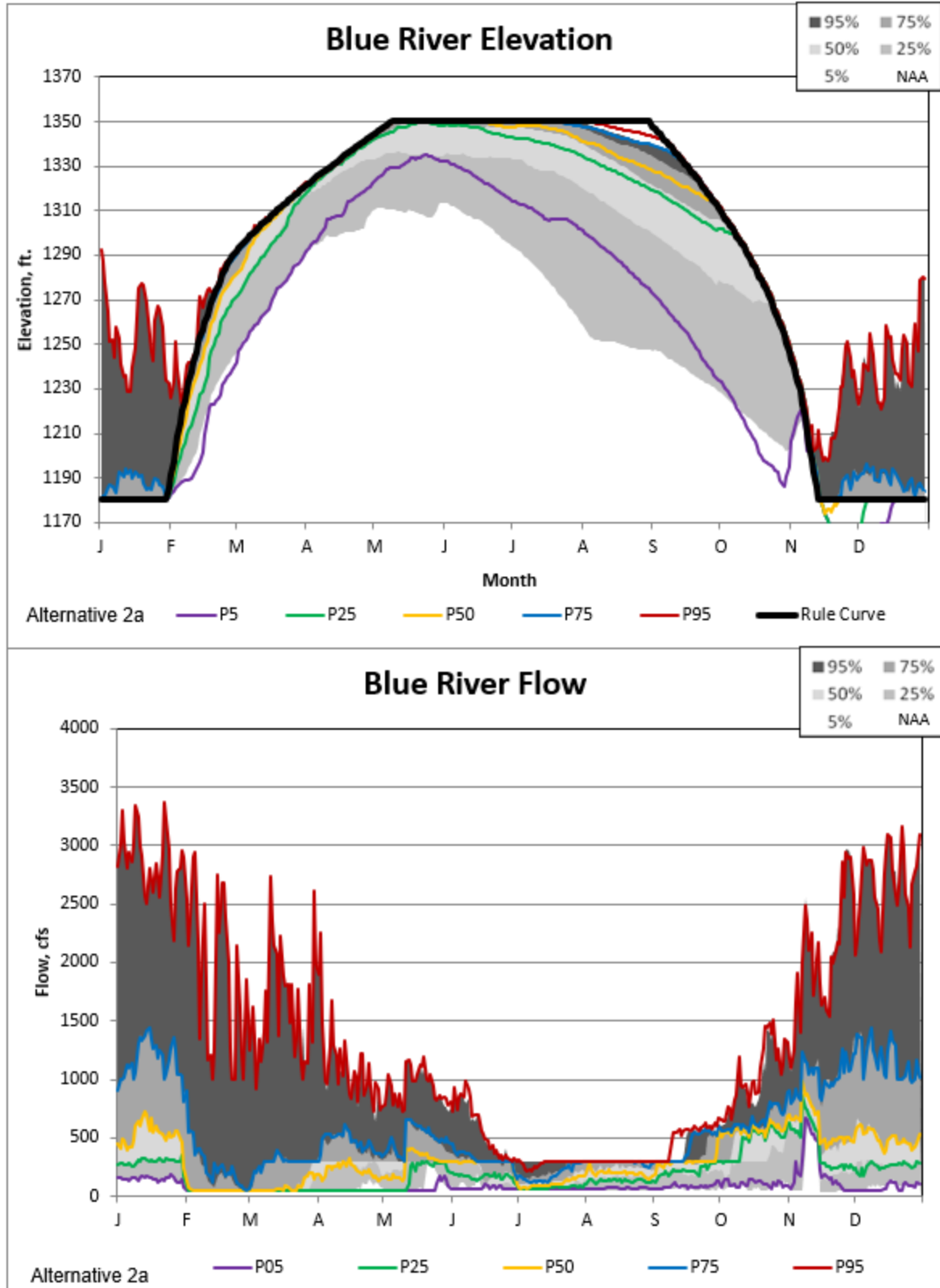

Figure 5-26. Blue River Alternative 2A Non-exceedance Plot.

Willamette Valley System Operations and Maintenance
Environmental Impact Statement

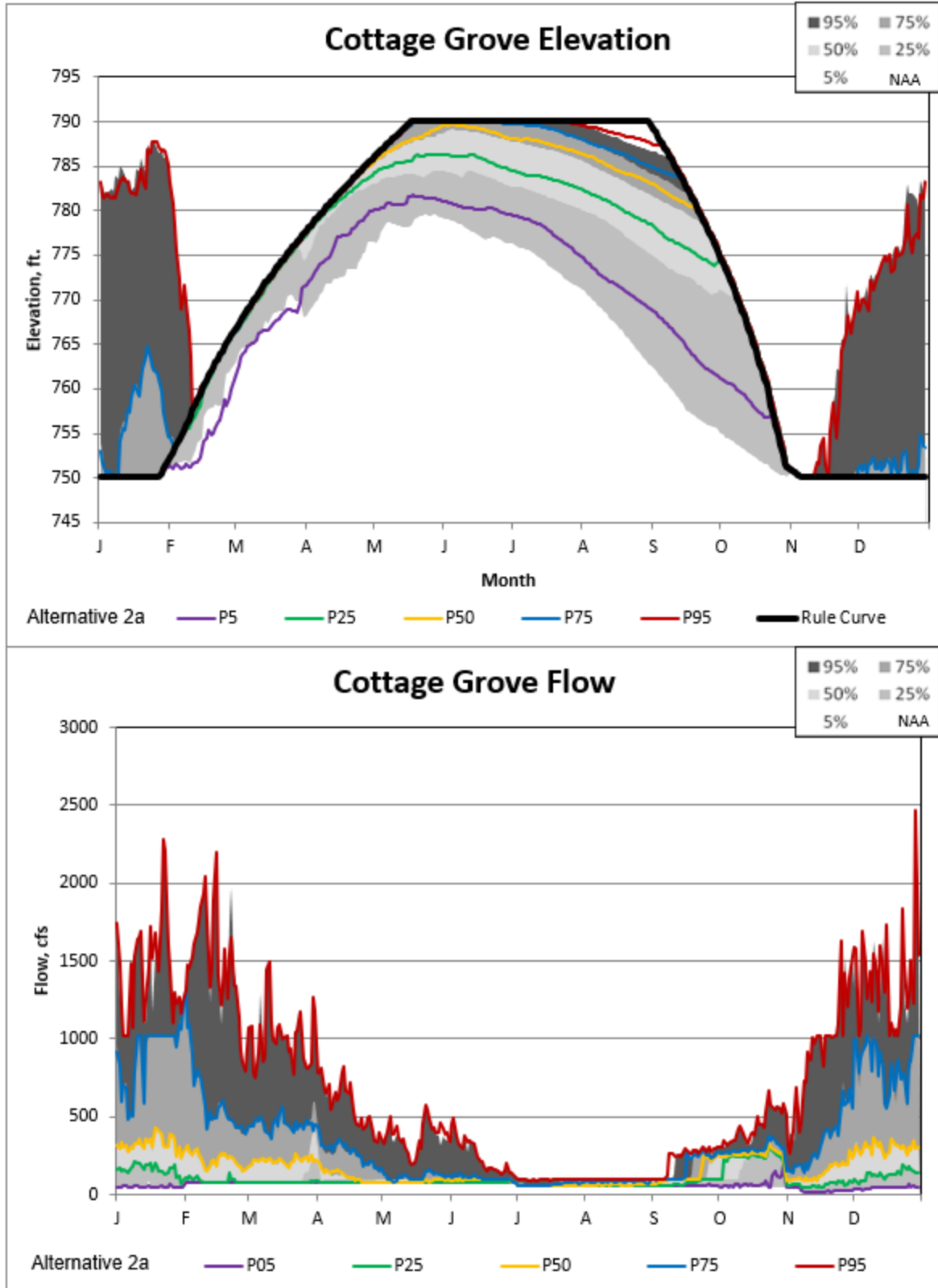

Figure 5-27. Cottage Grove Alternative 2A Non-exceedance Plot.

Willamette Valley System Operations and Maintenance
Environmental Impact Statement

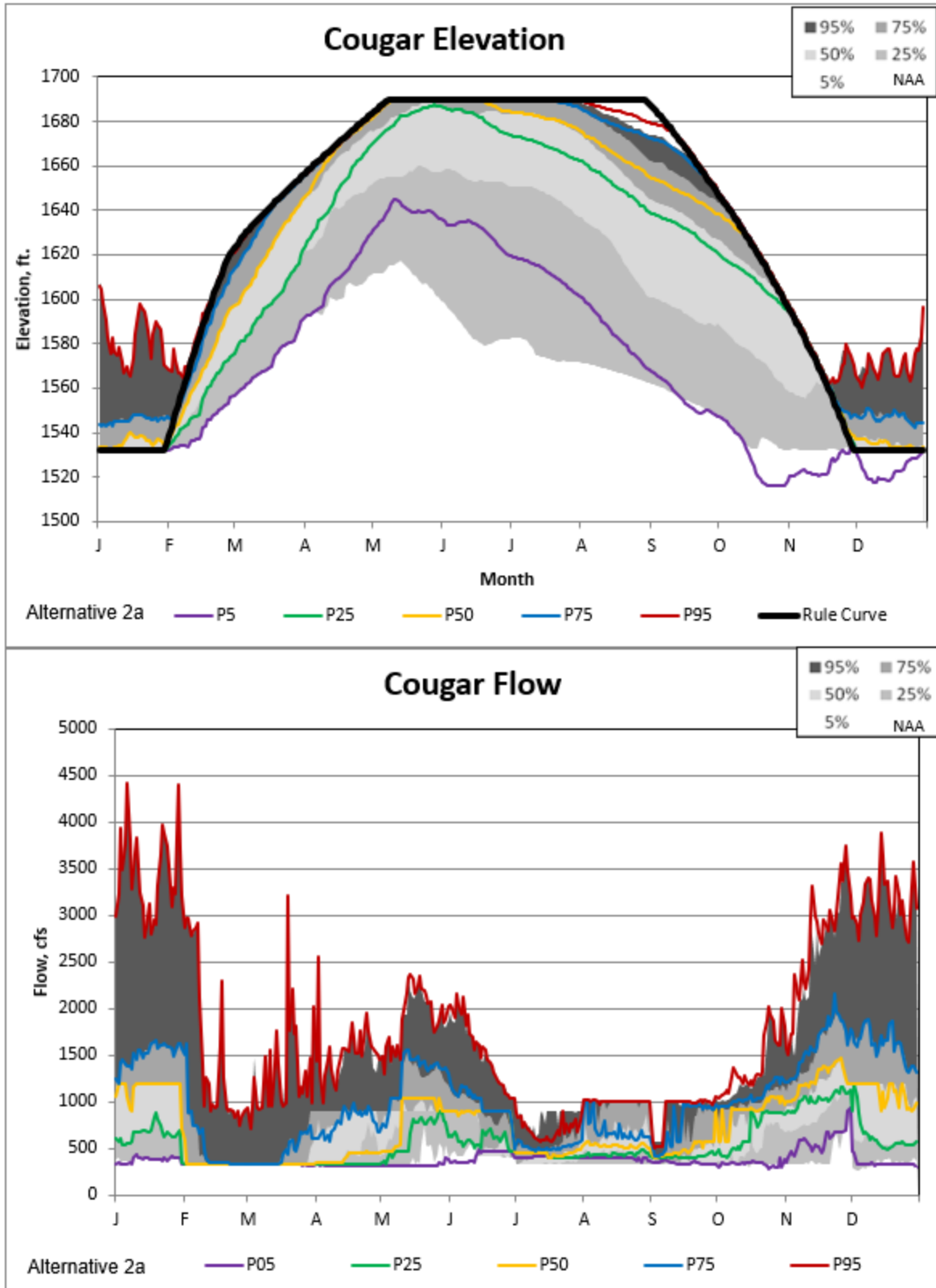

Figure 5-28. Cougar Alternative 2A Non-exceedance Plot.

Willamette Valley System Operations and Maintenance
Environmental Impact Statement

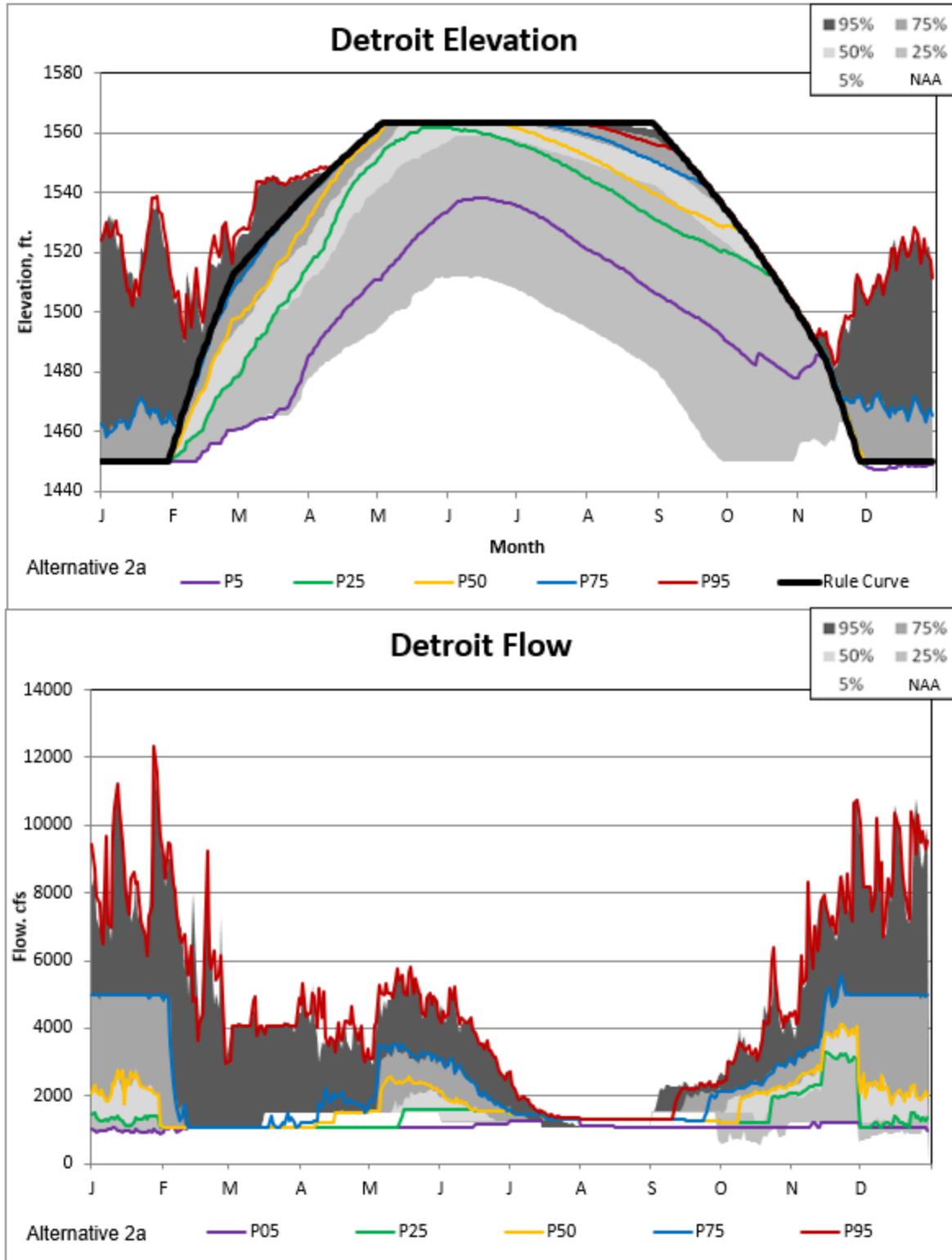

Figure 5-29. Detroit Alternative 2A Non-exceedance Plot.

Willamette Valley System Operations and Maintenance
Environmental Impact Statement

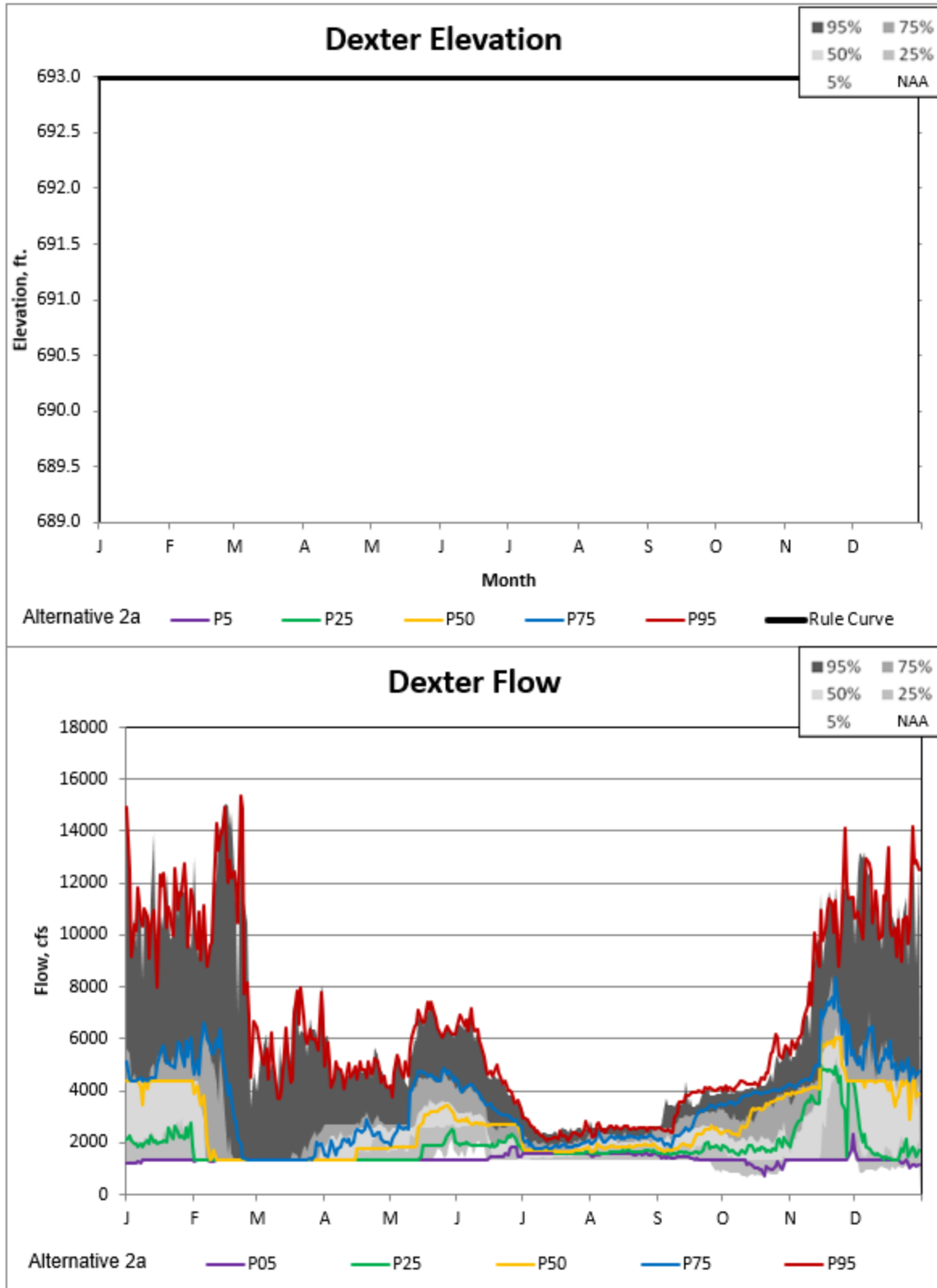

Figure 5-30. Dexter Alternative 2A Non-exceedance Plot.

Willamette Valley System Operations and Maintenance
Environmental Impact Statement

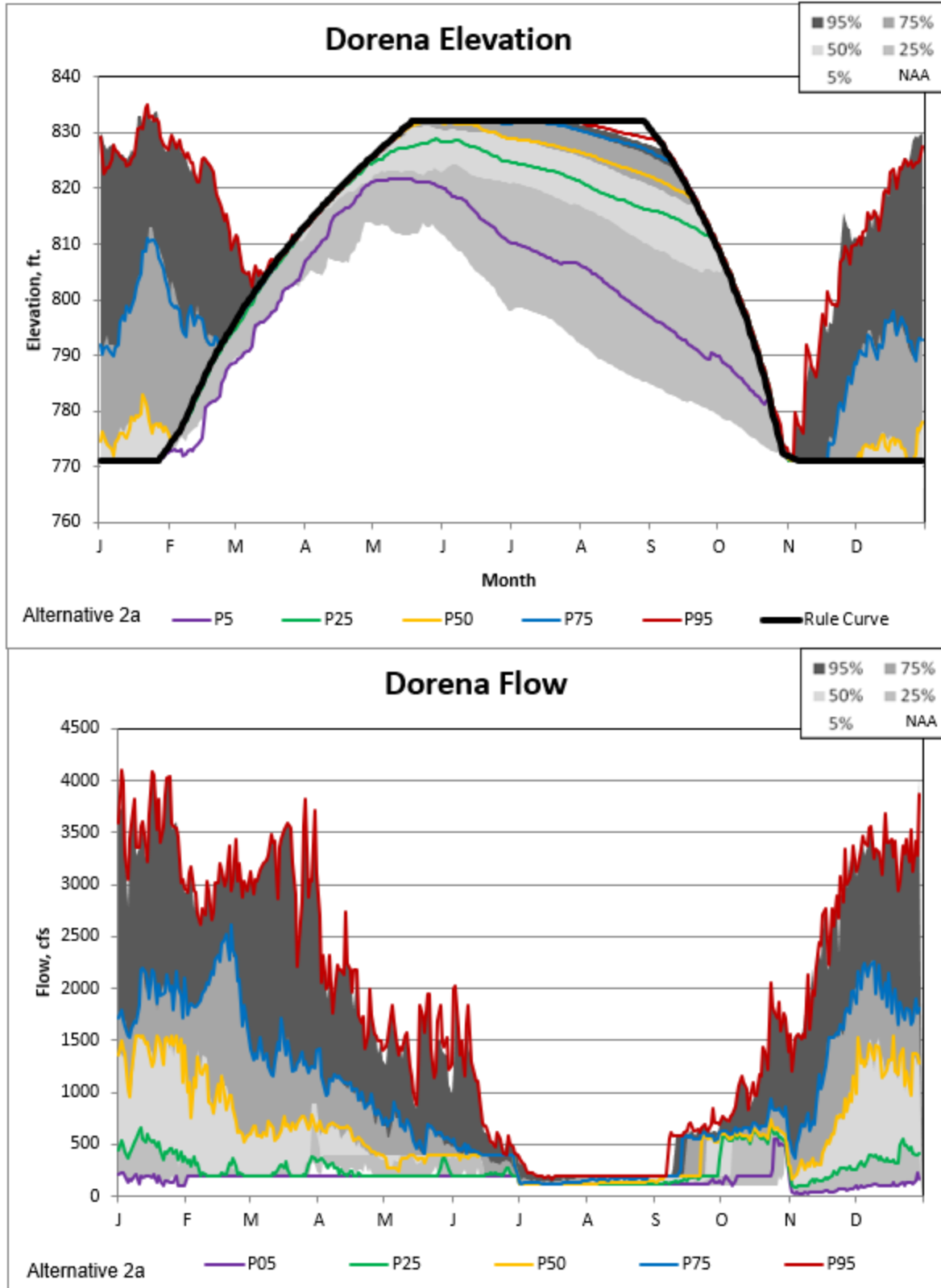

Figure 5-31. Dorena Alternative 2A Non-exceedance Plot.

Willamette Valley System Operations and Maintenance
Environmental Impact Statement

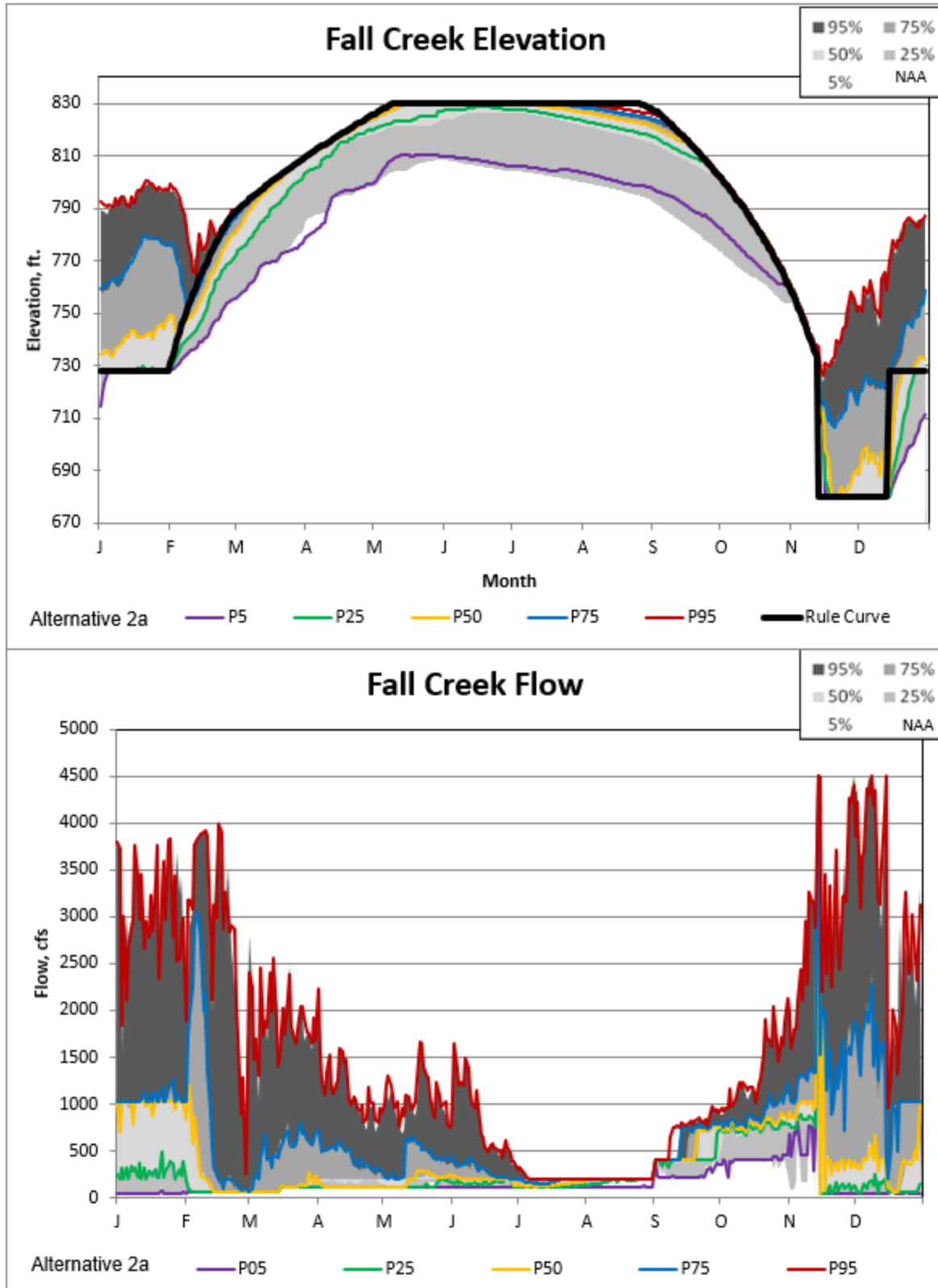

Figure 5-32. Fall Creek Alternative 2A Non-exceedance Plot.

Willamette Valley System Operations and Maintenance
Environmental Impact Statement

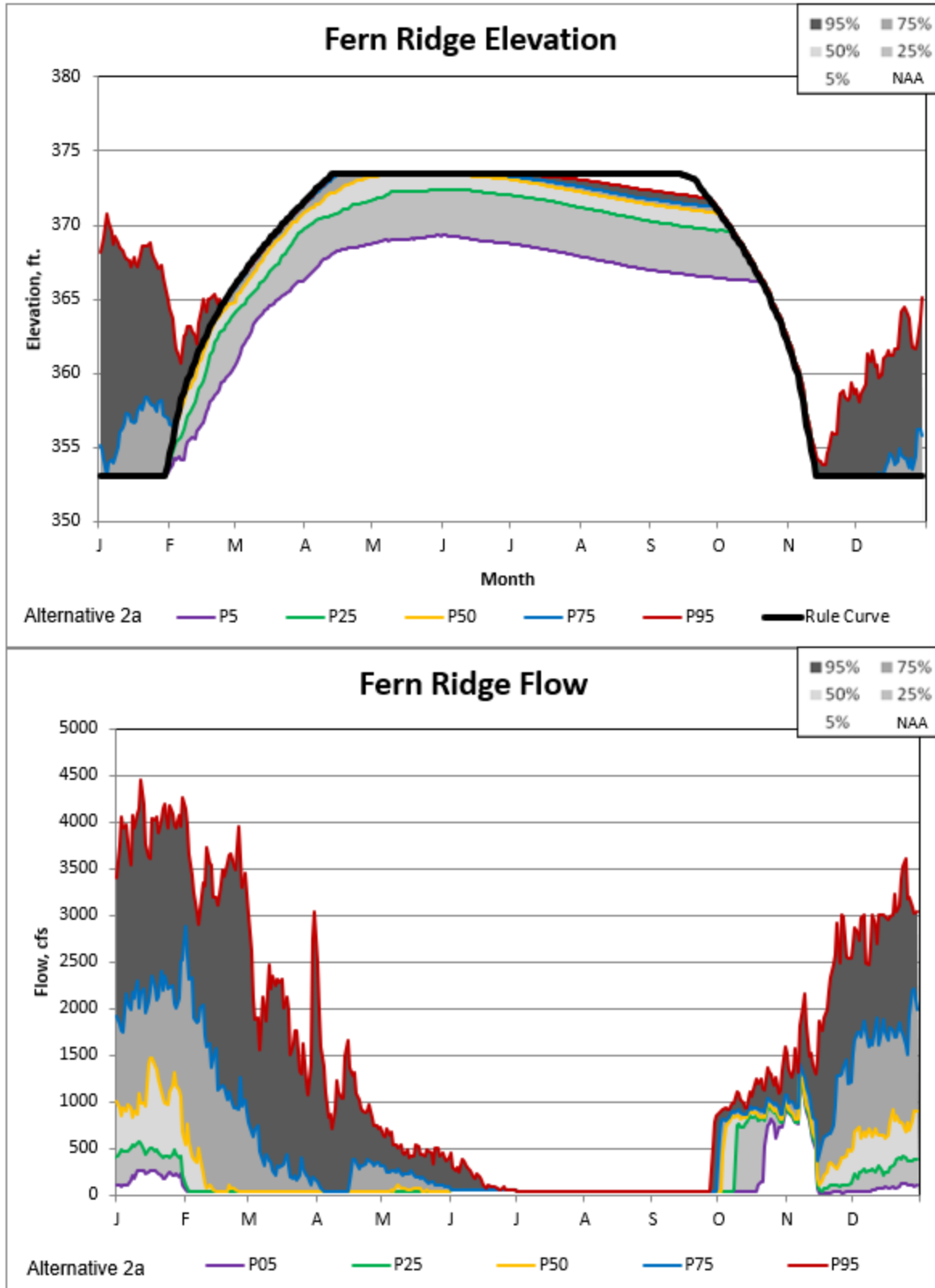

Figure 5-33. Fern Ridge Alternative 2A Non-exceedance Plot.

Willamette Valley System Operations and Maintenance
Environmental Impact Statement

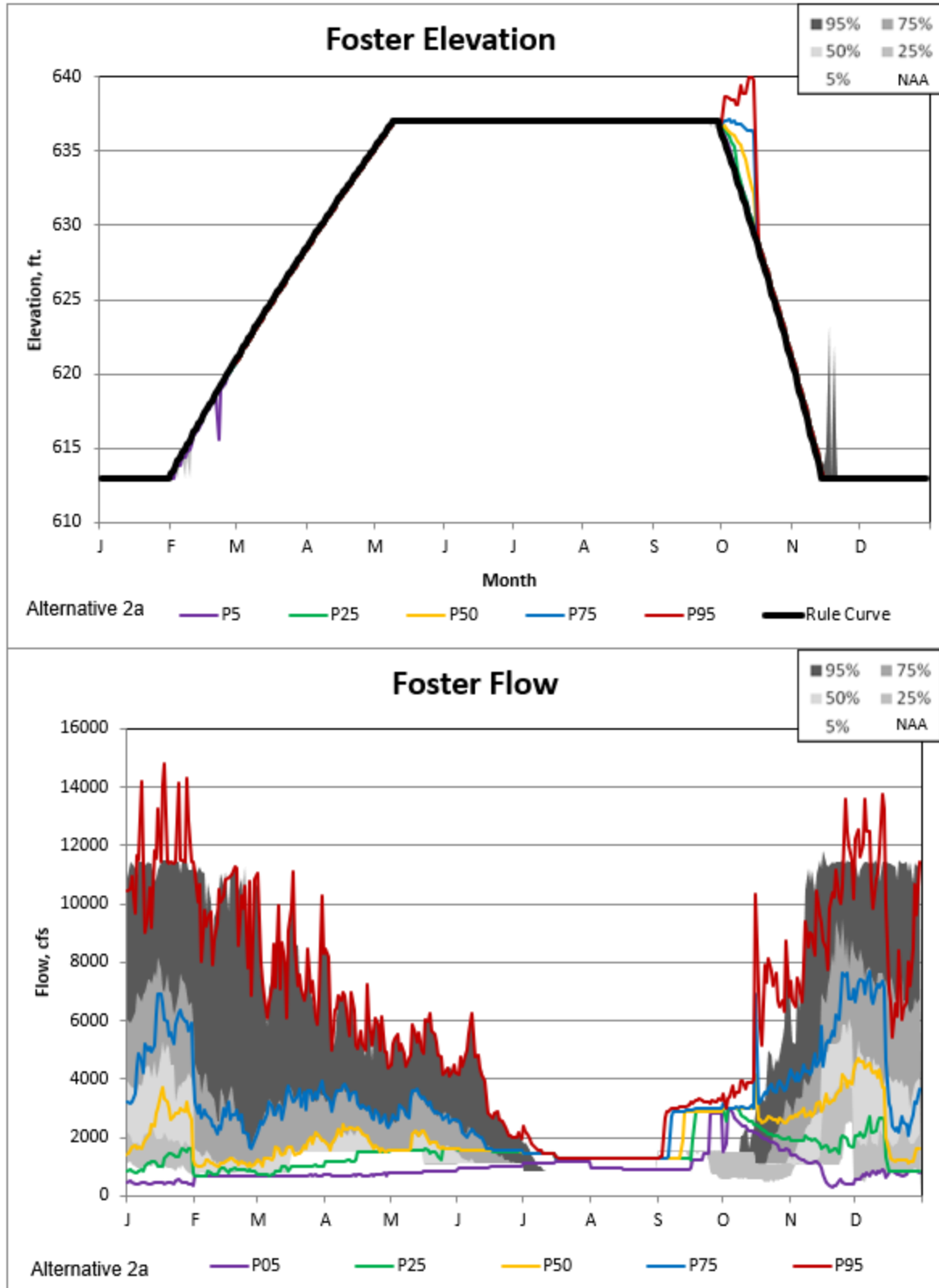

Figure 5-34. Foster Alternative 2A Non-exceedance Plot.

Willamette Valley System Operations and Maintenance
Environmental Impact Statement

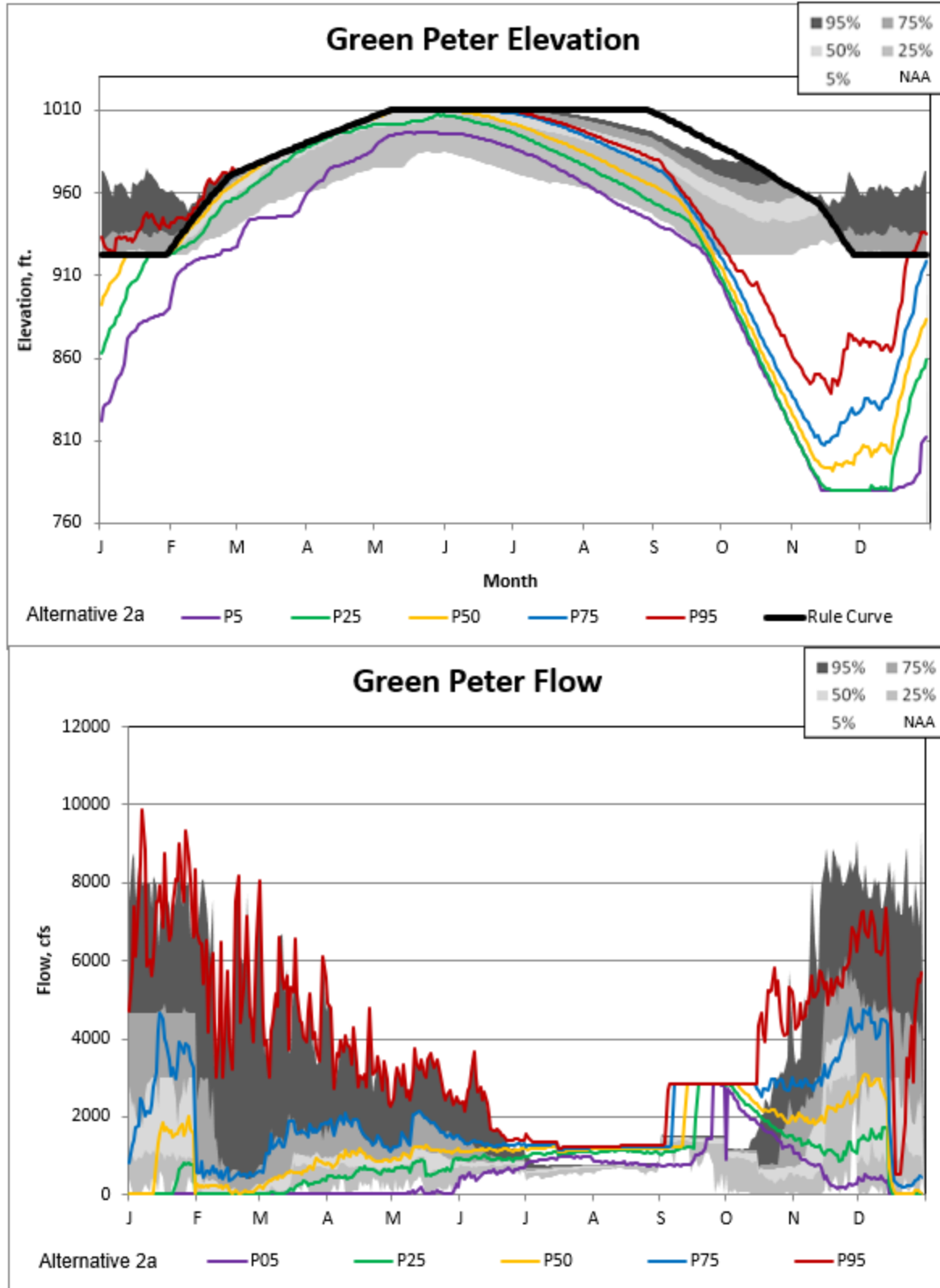

Figure 5-35. Green Peter Alternative 2A Non-exceedance Plot.

Willamette Valley System Operations and Maintenance
Environmental Impact Statement

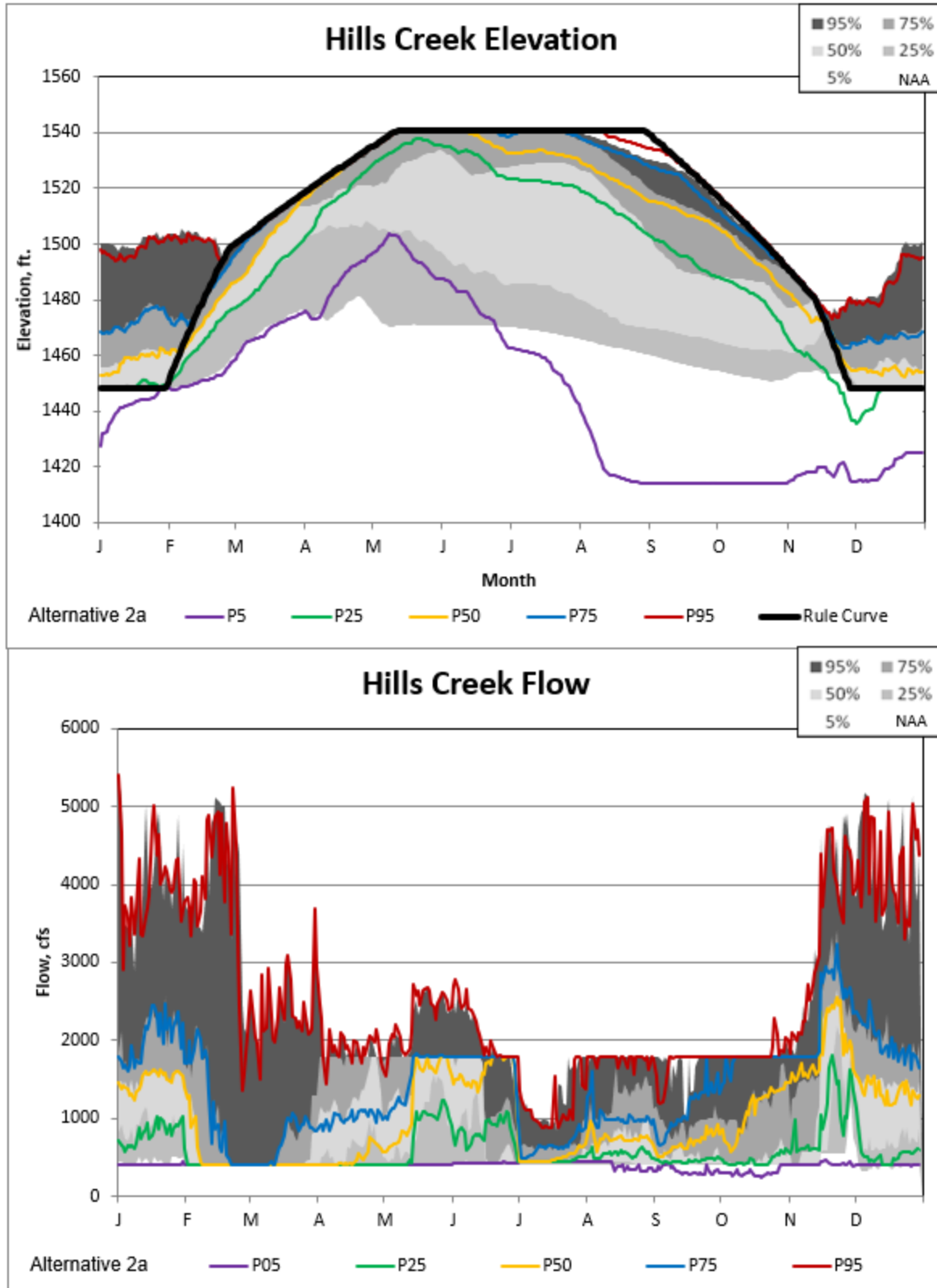

Figure 5-36. Hills Creek Alternative 2A Non-exceedance Plot.

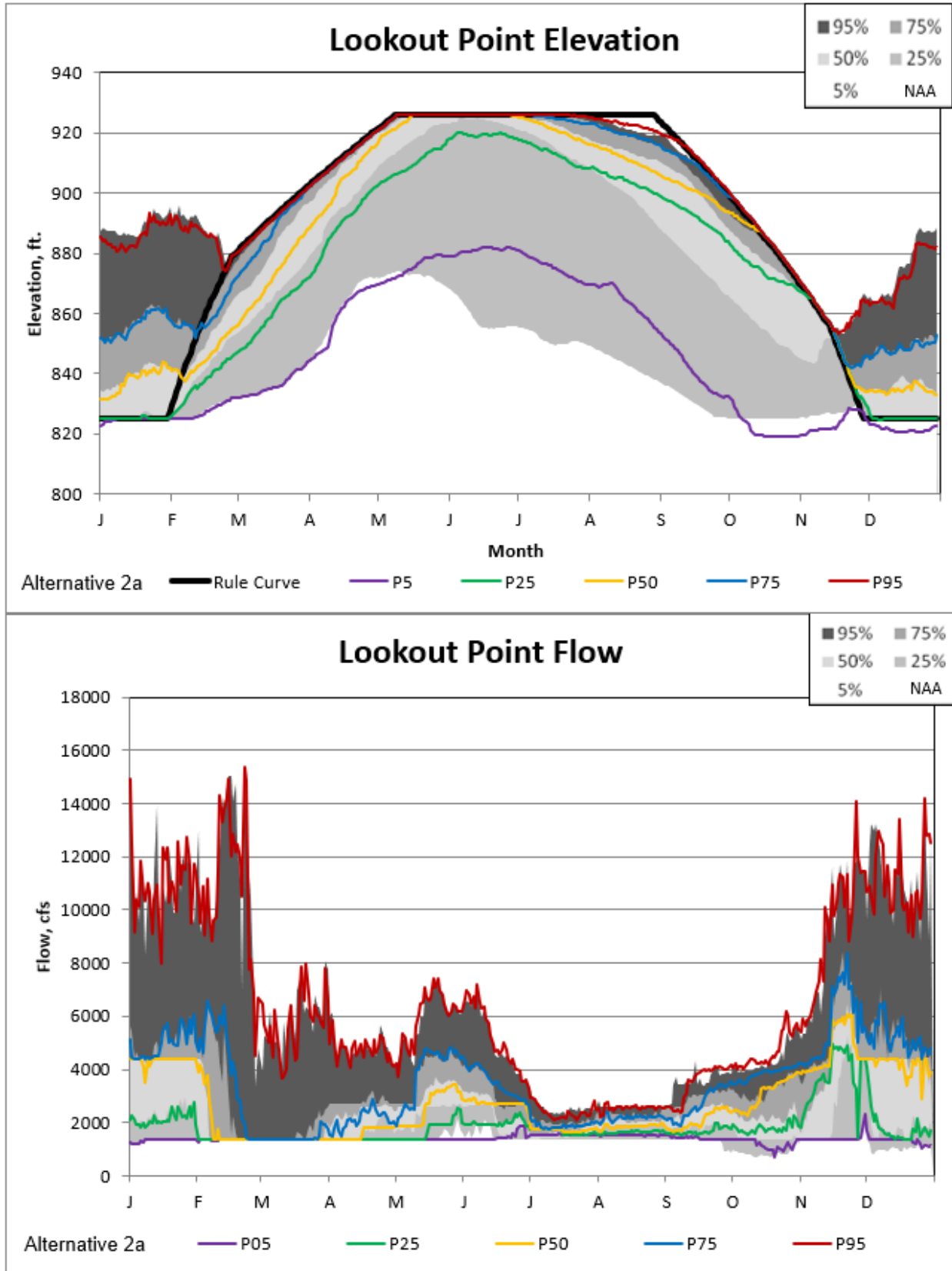

Figure 5-37. Lookout Point Alternative 2A Non-exceedance Plot.

Willamette Valley System Operations and Maintenance
Environmental Impact Statement

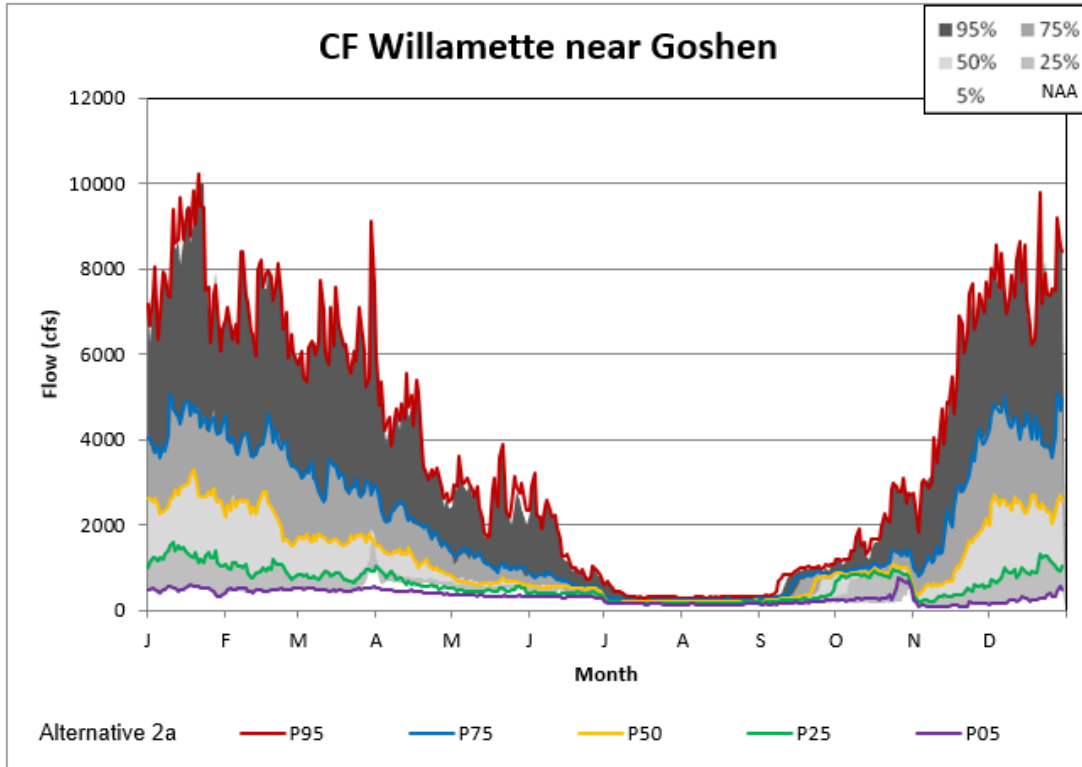

Figure 5-38. Goshen Alternative 2A Non-exceedance Plot.

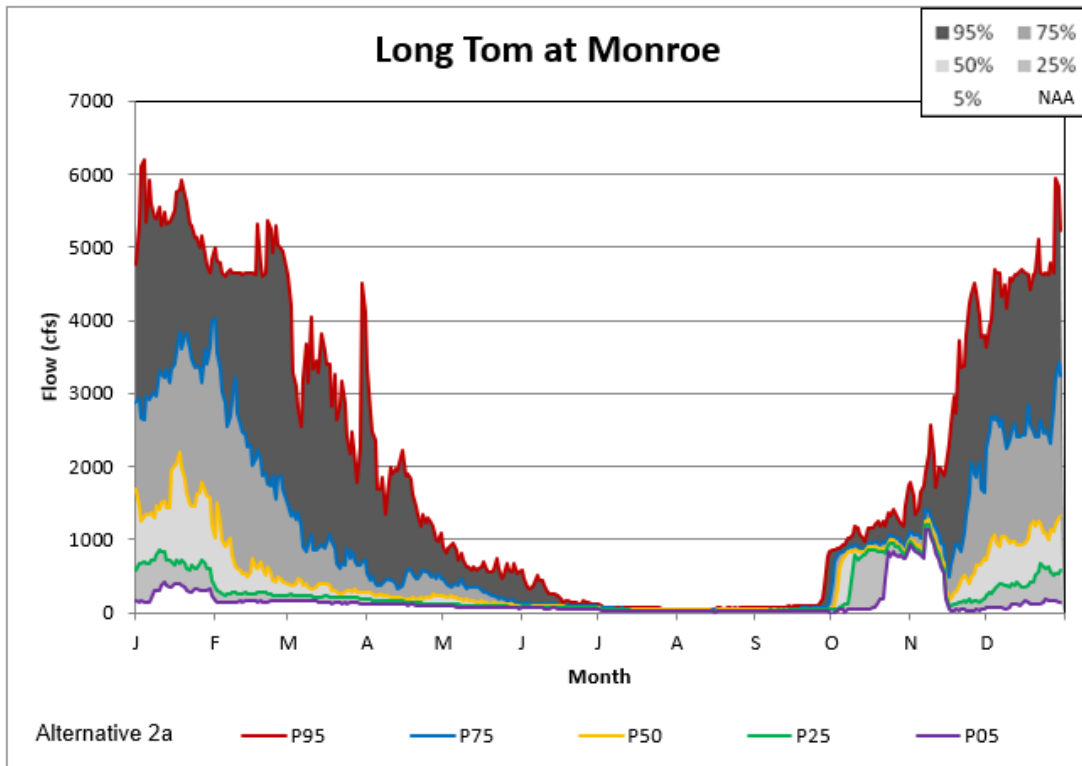

Figure 5-39. Monroe Alternative 2A Non-exceedance Plot.

*Willamette Valley System Operations and Maintenance
Environmental Impact Statement*

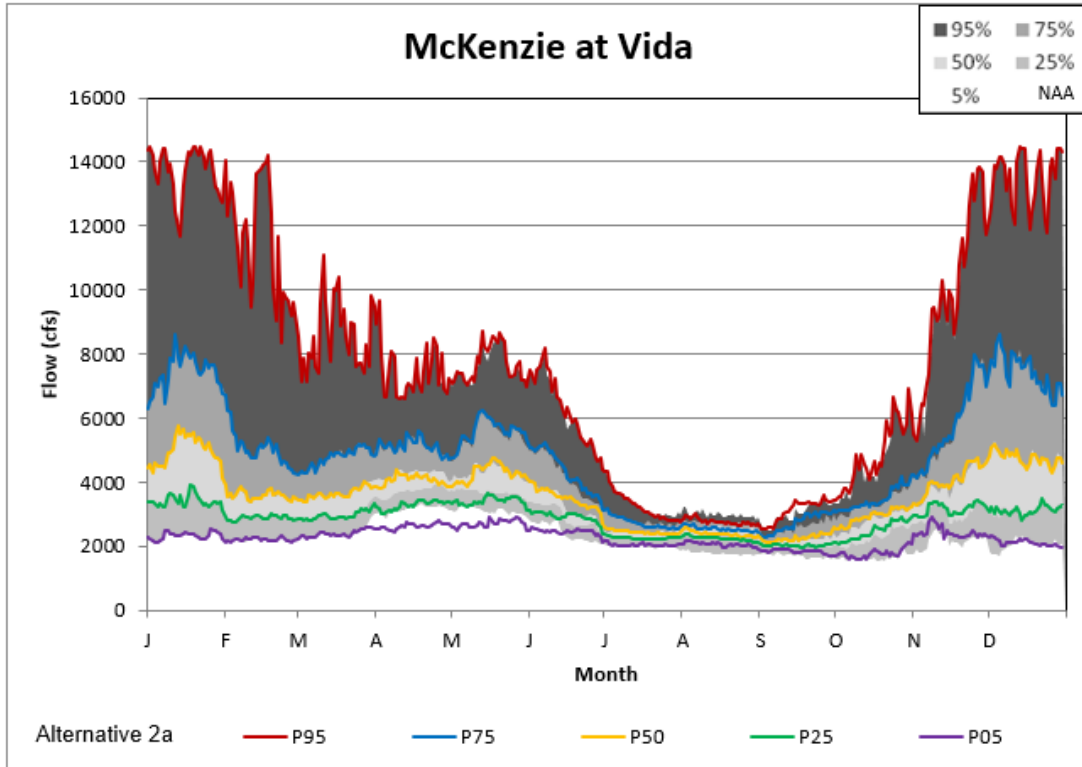

Figure 5-40. Vida Alternative 2A Non-exceedance Plot.

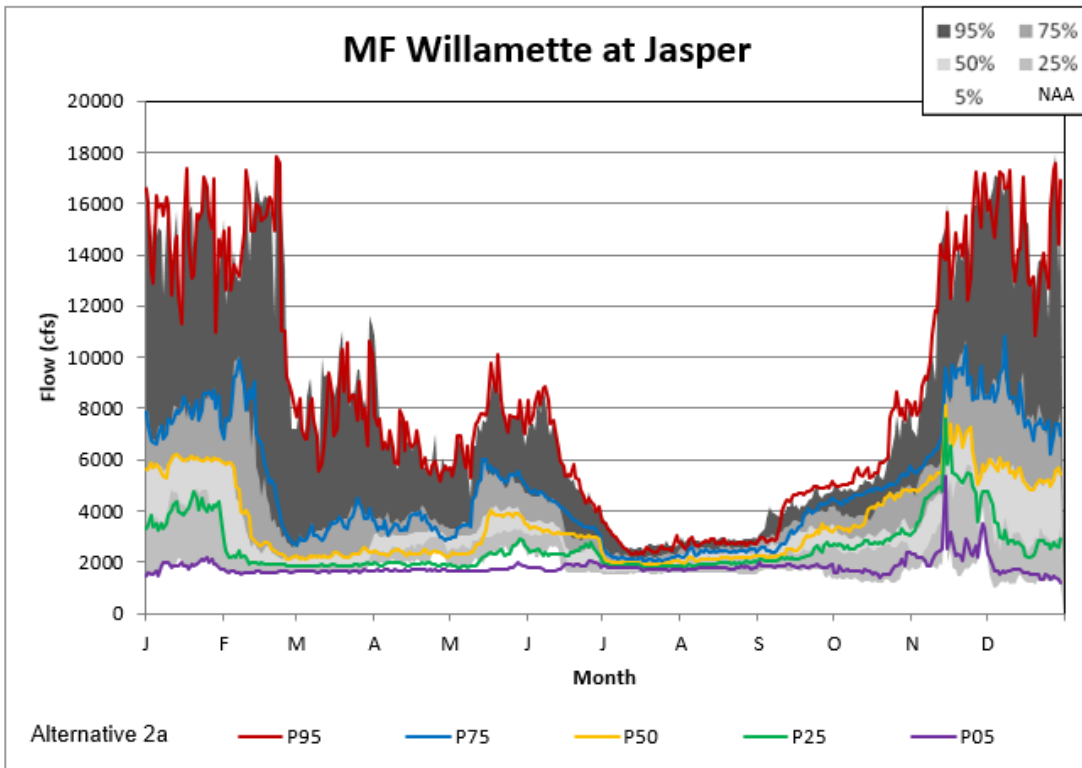

Figure 5-41. Jasper Alternative 2A Non-exceedance Plot.

Willamette Valley System Operations and Maintenance
Environmental Impact Statement

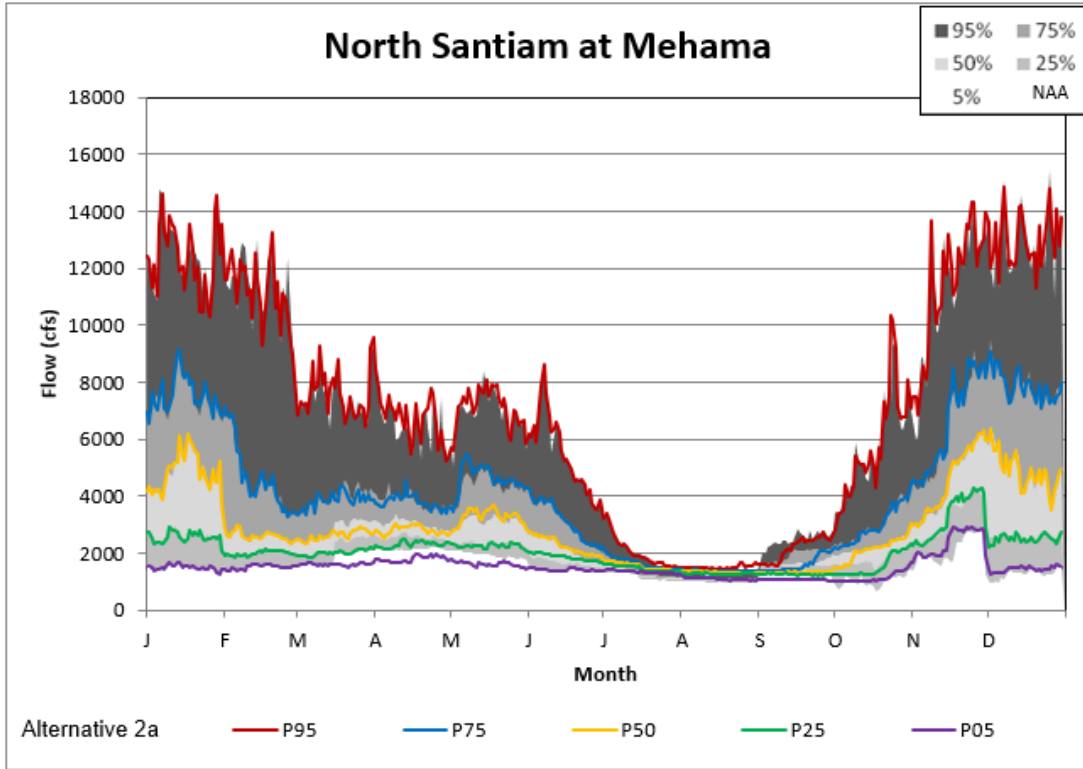

Figure 5-42. Mehama Alternative 2A Non-exceedance Plot.

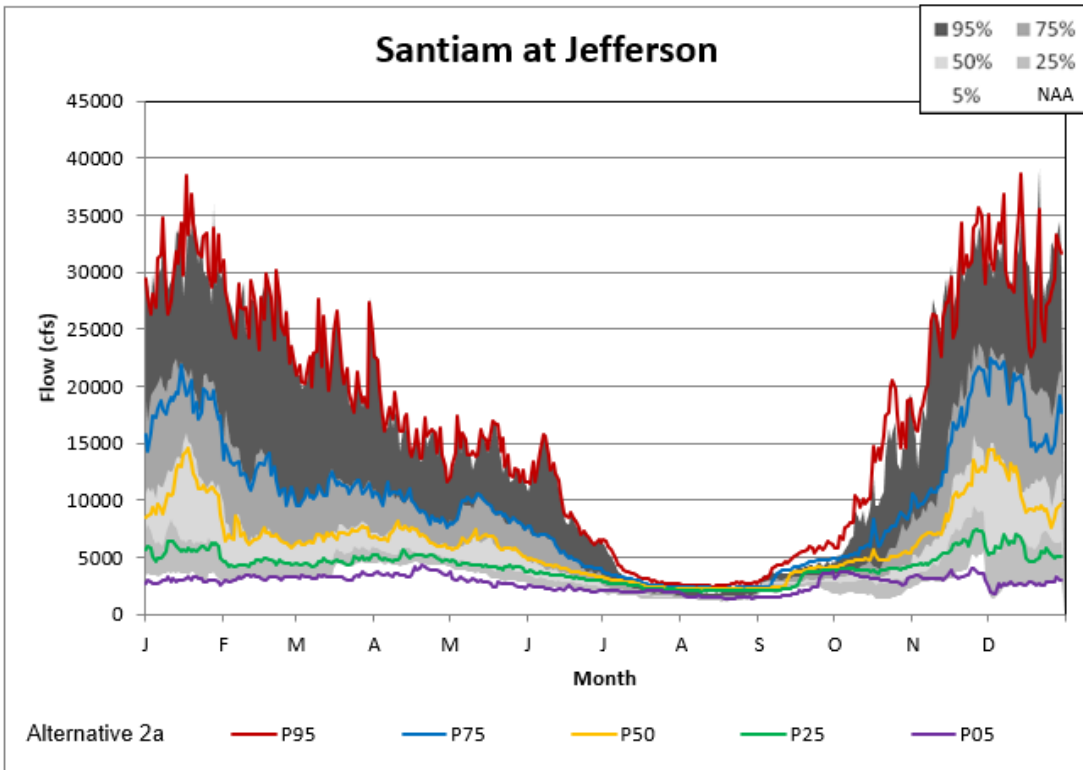

Figure 5-43. Jefferson Alternative 2A Non-exceedance Plot.

*Willamette Valley System Operations and Maintenance
Environmental Impact Statement*

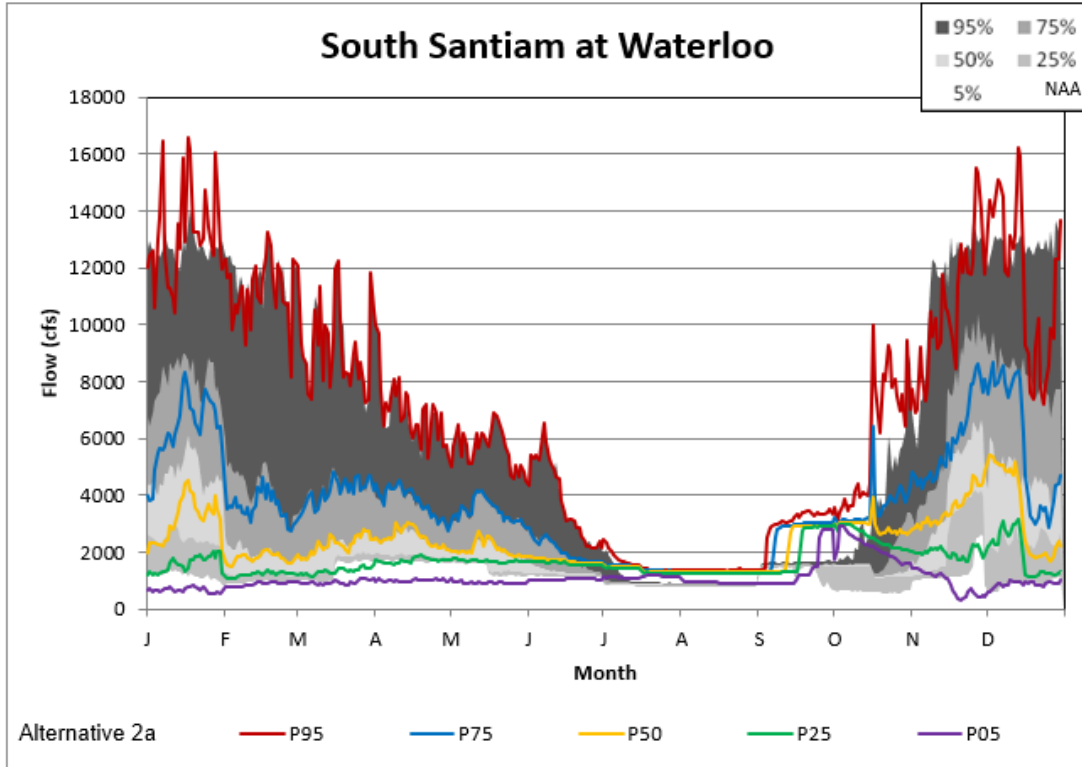

Figure 5-44. Waterloo Alternative 2A Non-exceedance Plot.

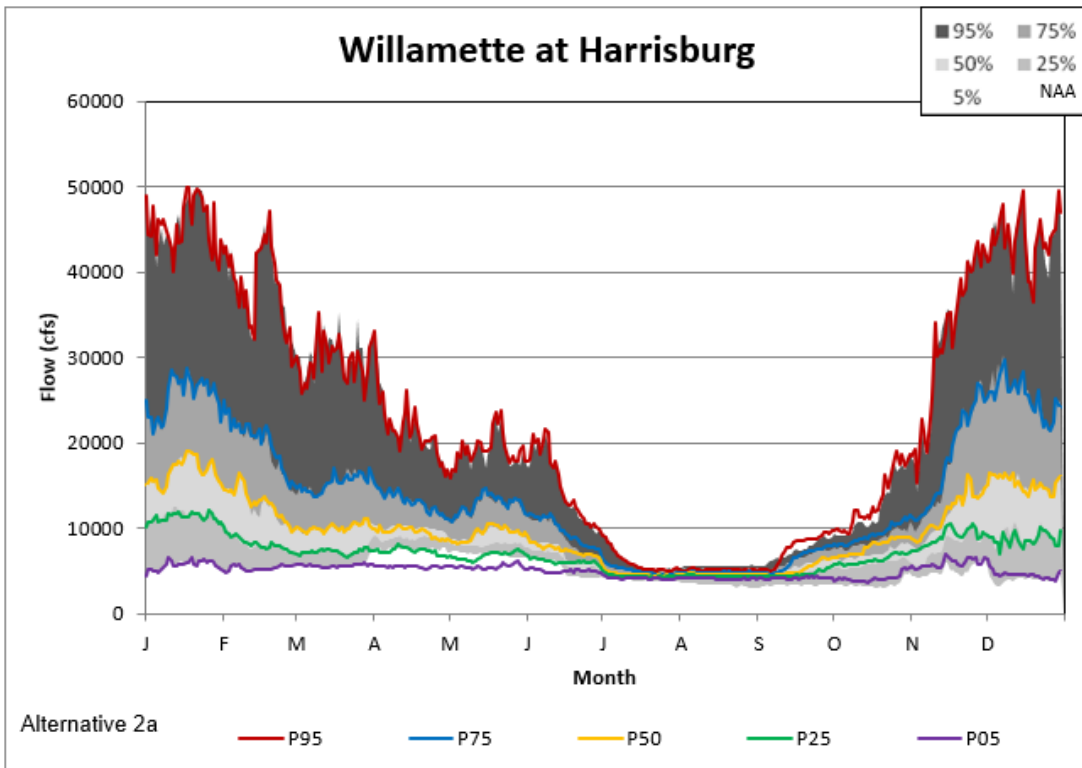

Figure 5-45. Harrisburg Alternative 2A Non-exceedance Plot.

*Willamette Valley System Operations and Maintenance
Environmental Impact Statement*

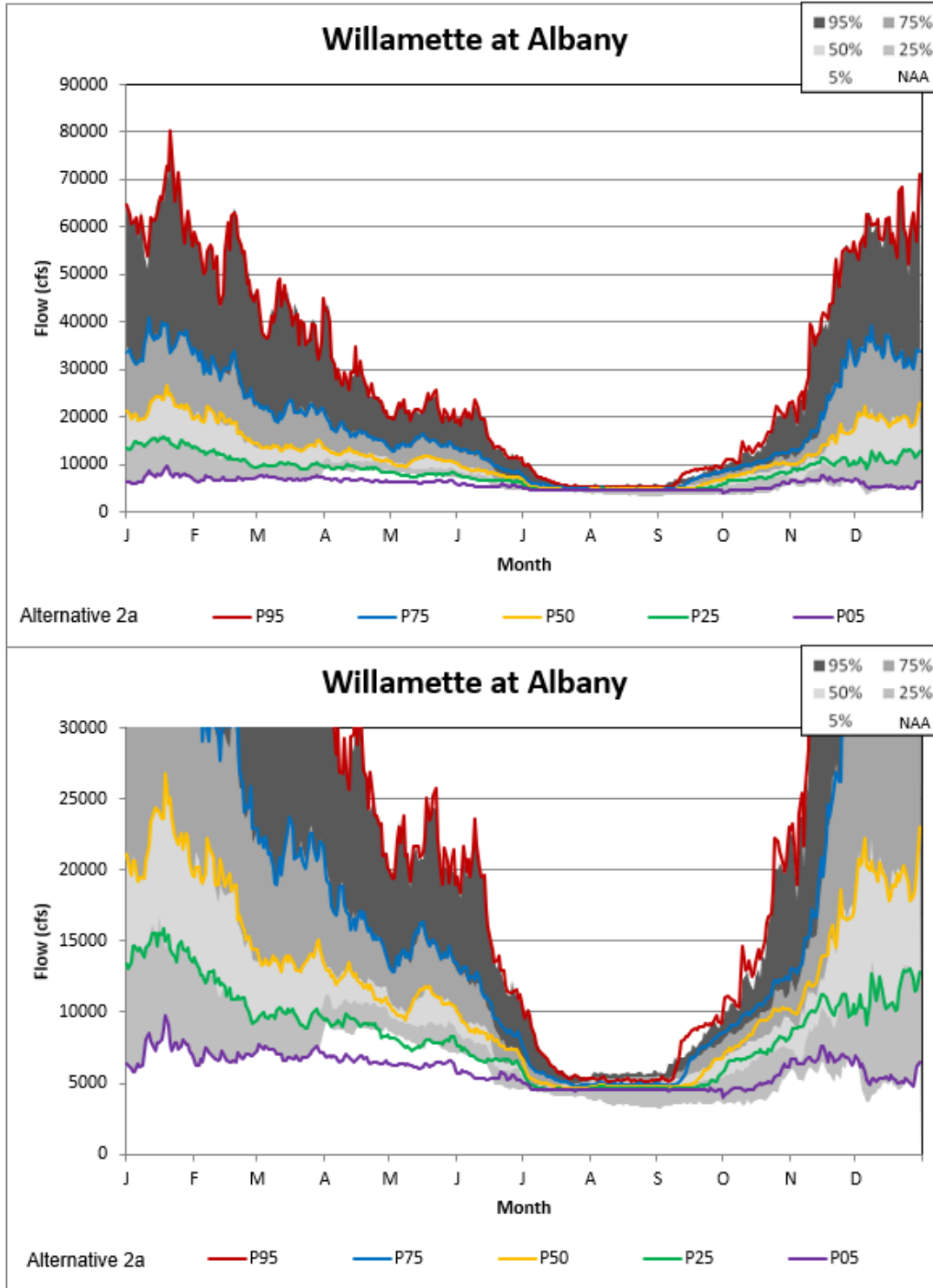

Figure 5-46. Albany Alternative 2A Non-exceedance Plot.

Willamette Valley System Operations and Maintenance
Environmental Impact Statement

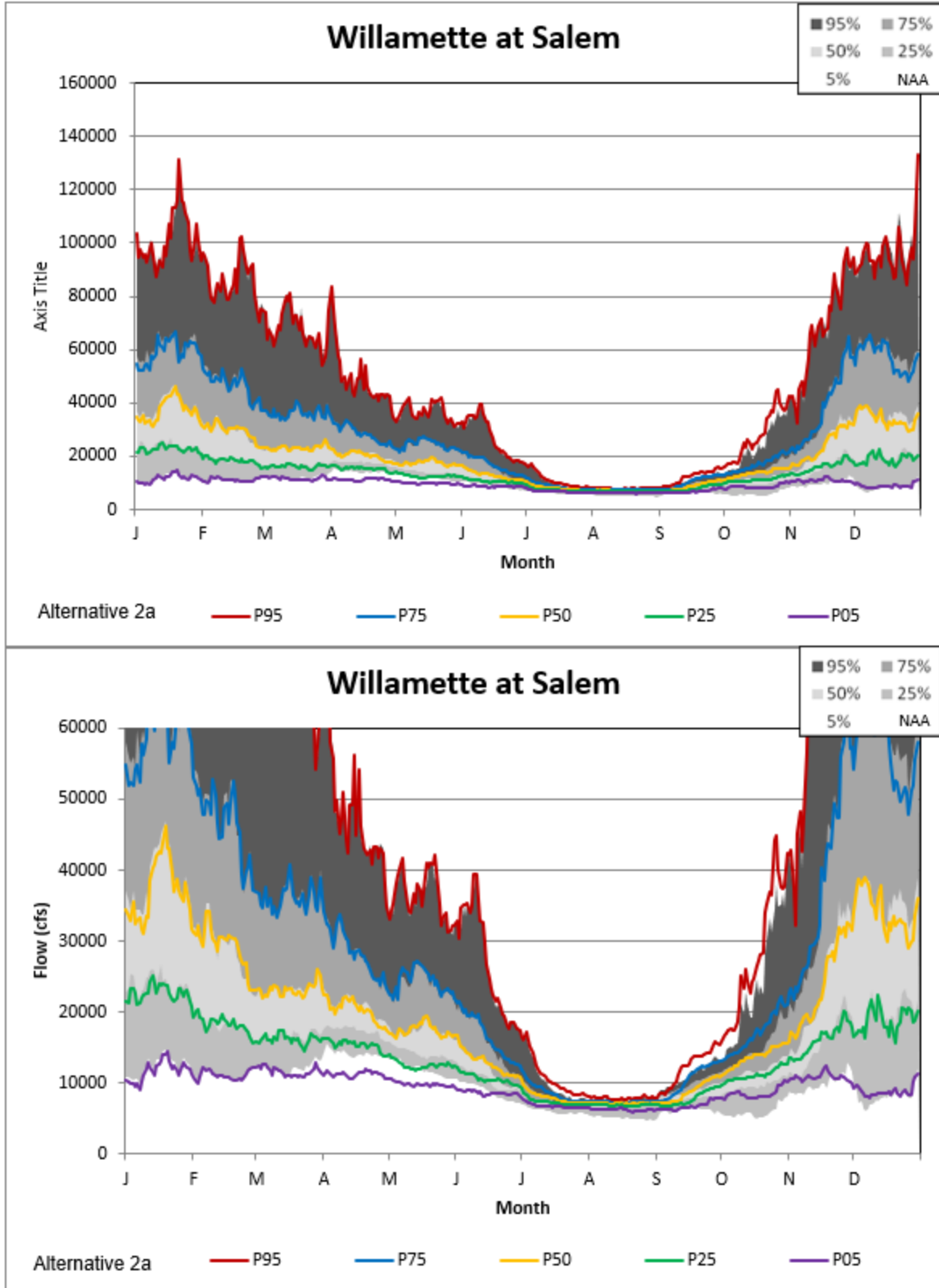

Figure 5-47. Salem Alternative 2A Non-exceedance Plot.

5.3 Alternative 2B

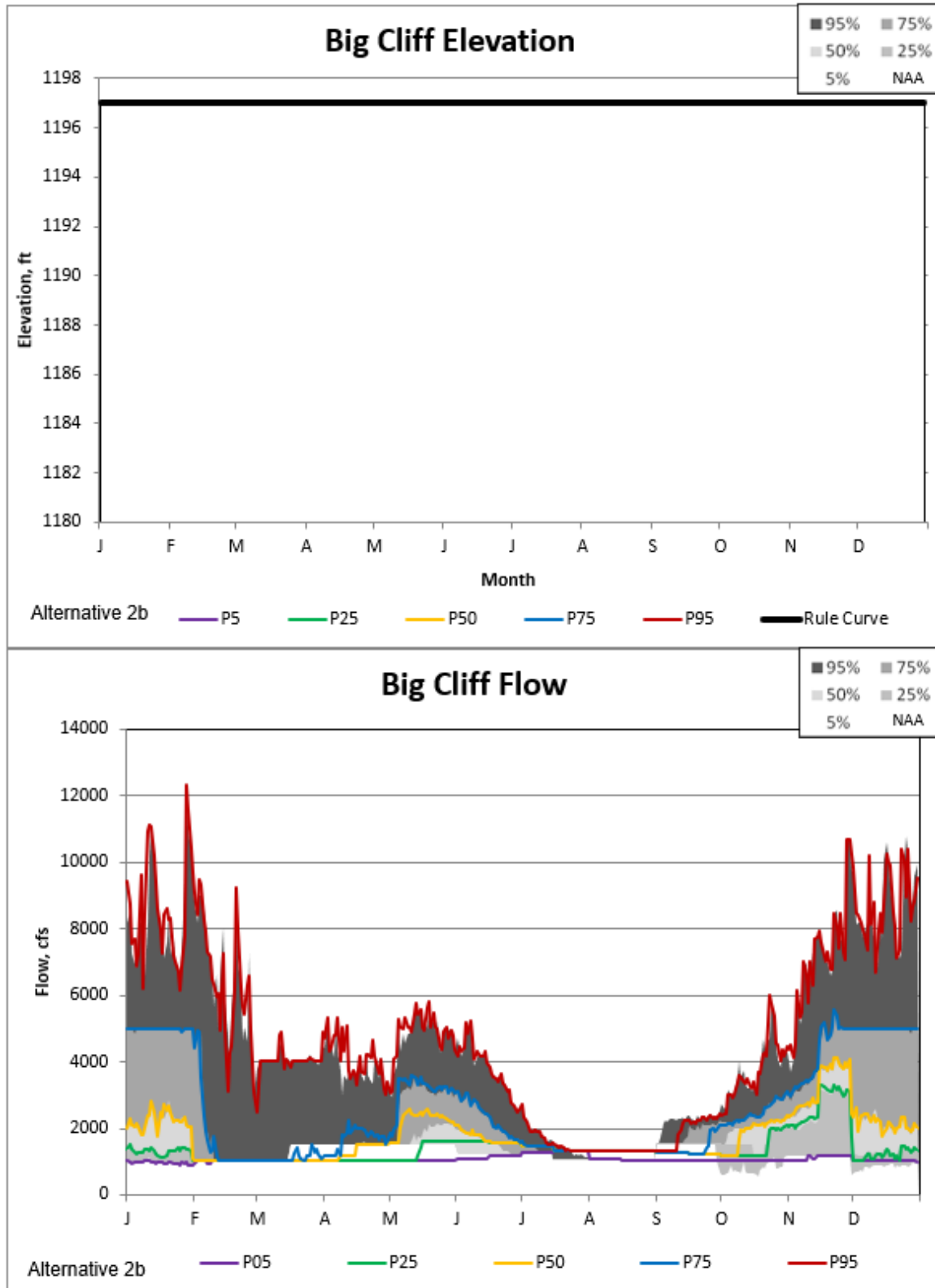

Figure 5-48. Big Cliff Alternative 2B Non-exceedance Plot.

Willamette Valley System Operations and Maintenance
Environmental Impact Statement

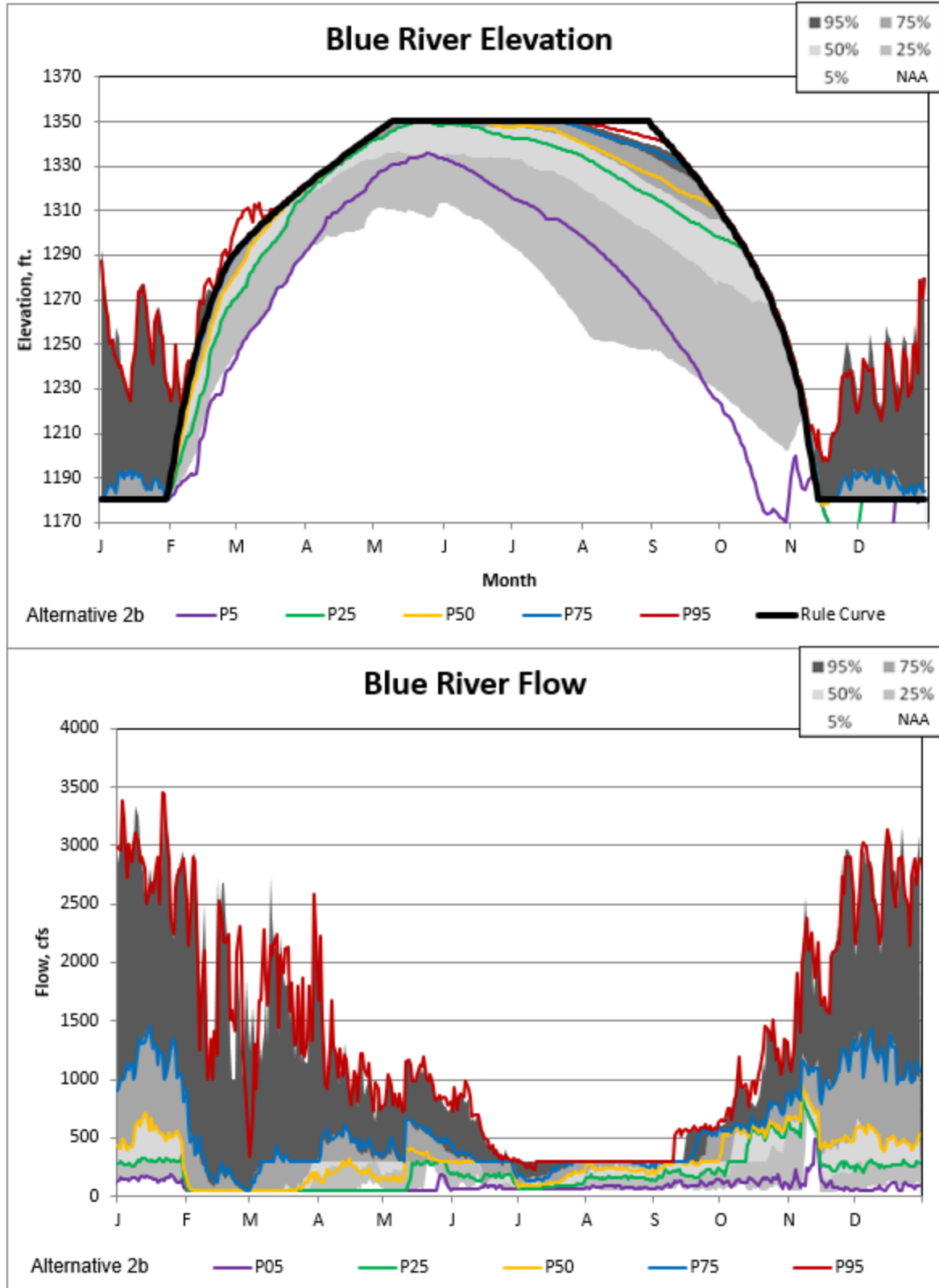

Figure 5-49. Blue River Alternative 2B Non-exceedance Plot.

Willamette Valley System Operations and Maintenance
Environmental Impact Statement

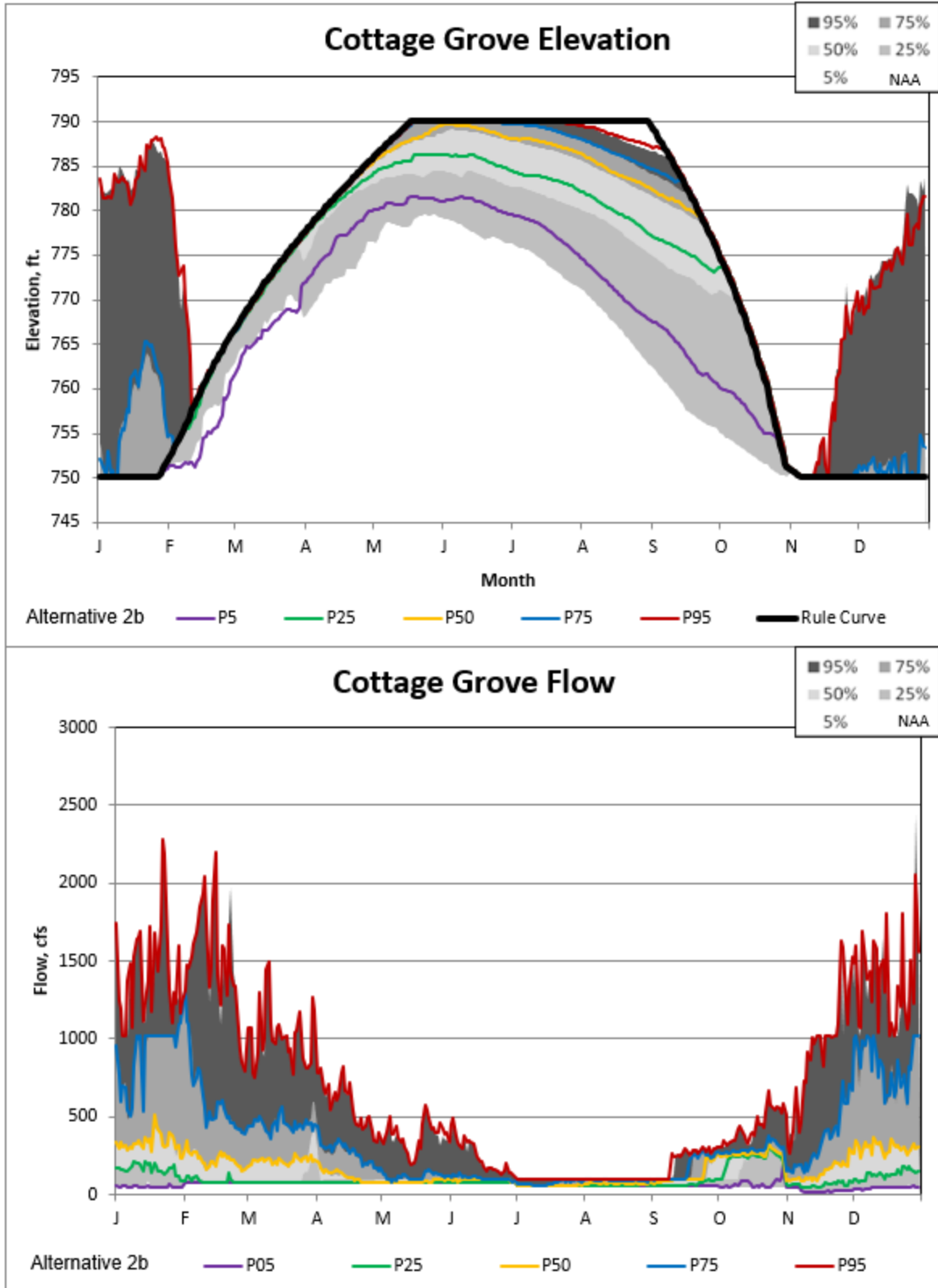

Figure 5-50. Cottage Grove Alternative 2B Non-exceedance Plot.

Willamette Valley System Operations and Maintenance
Environmental Impact Statement

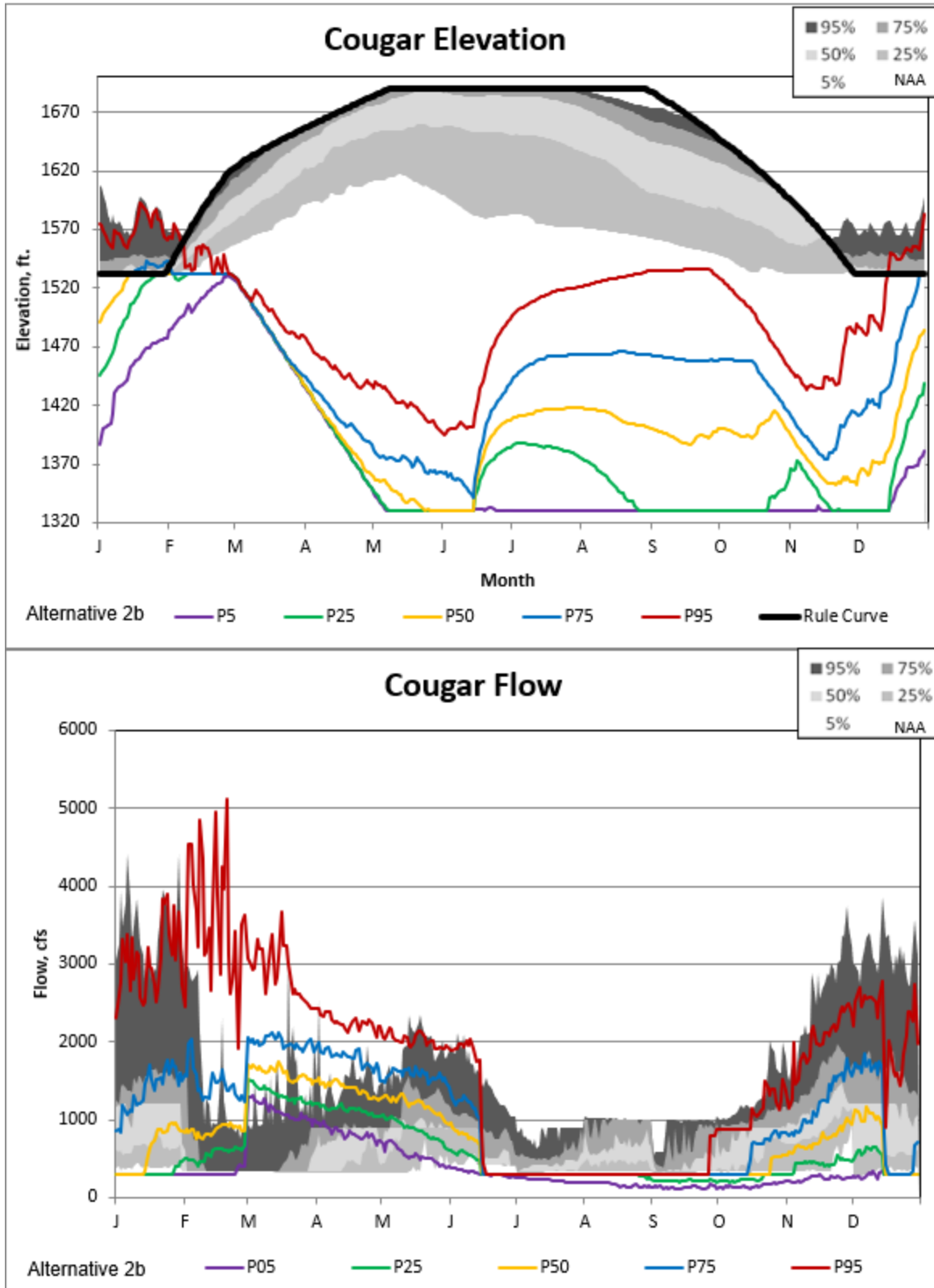

Figure 5-51. Cougar Alternative 2B Non-exceedance Plot.

Willamette Valley System Operations and Maintenance
Environmental Impact Statement

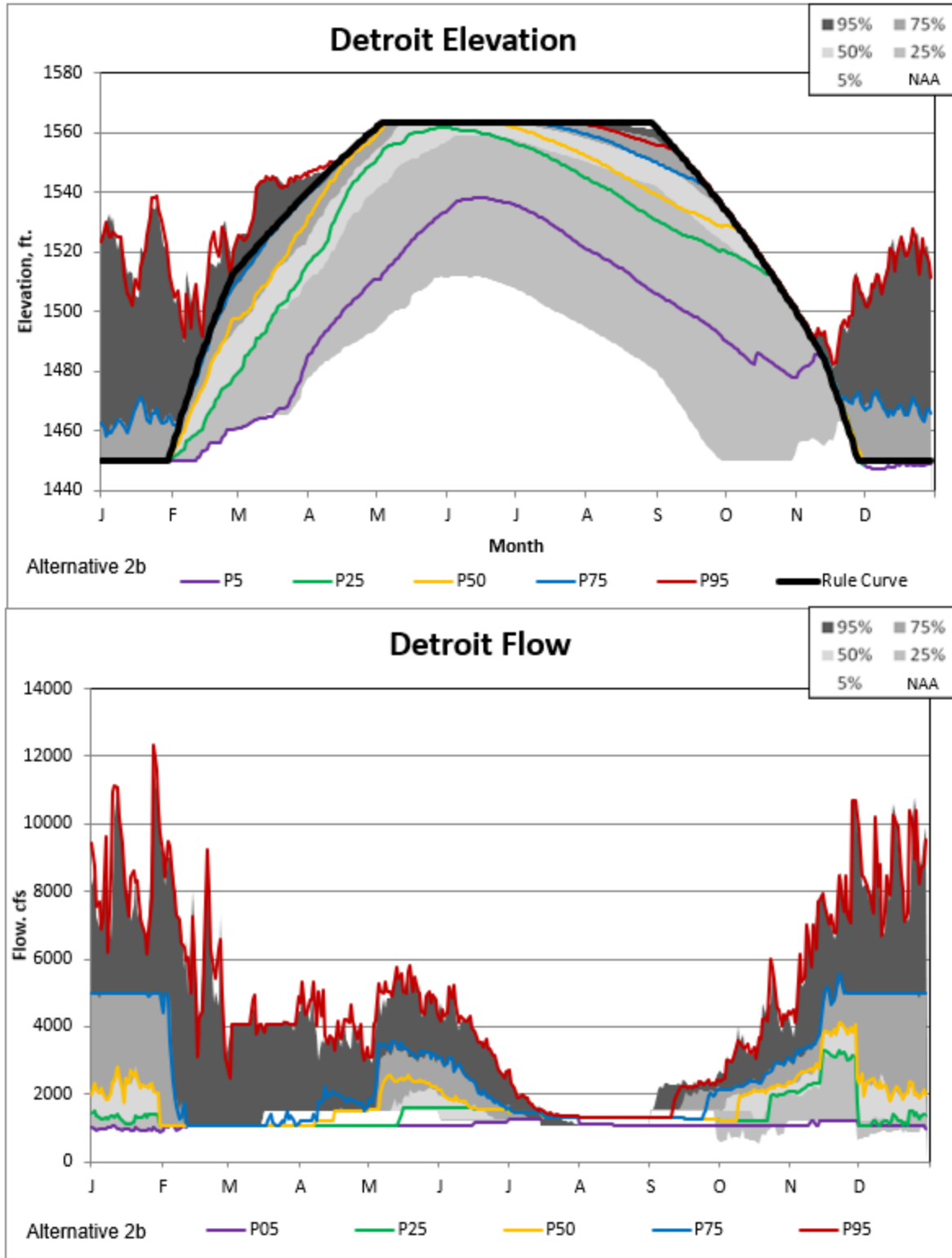

Figure 5-52. Detroit Alternative 2B Non-exceedance Plot.

Willamette Valley System Operations and Maintenance
Environmental Impact Statement

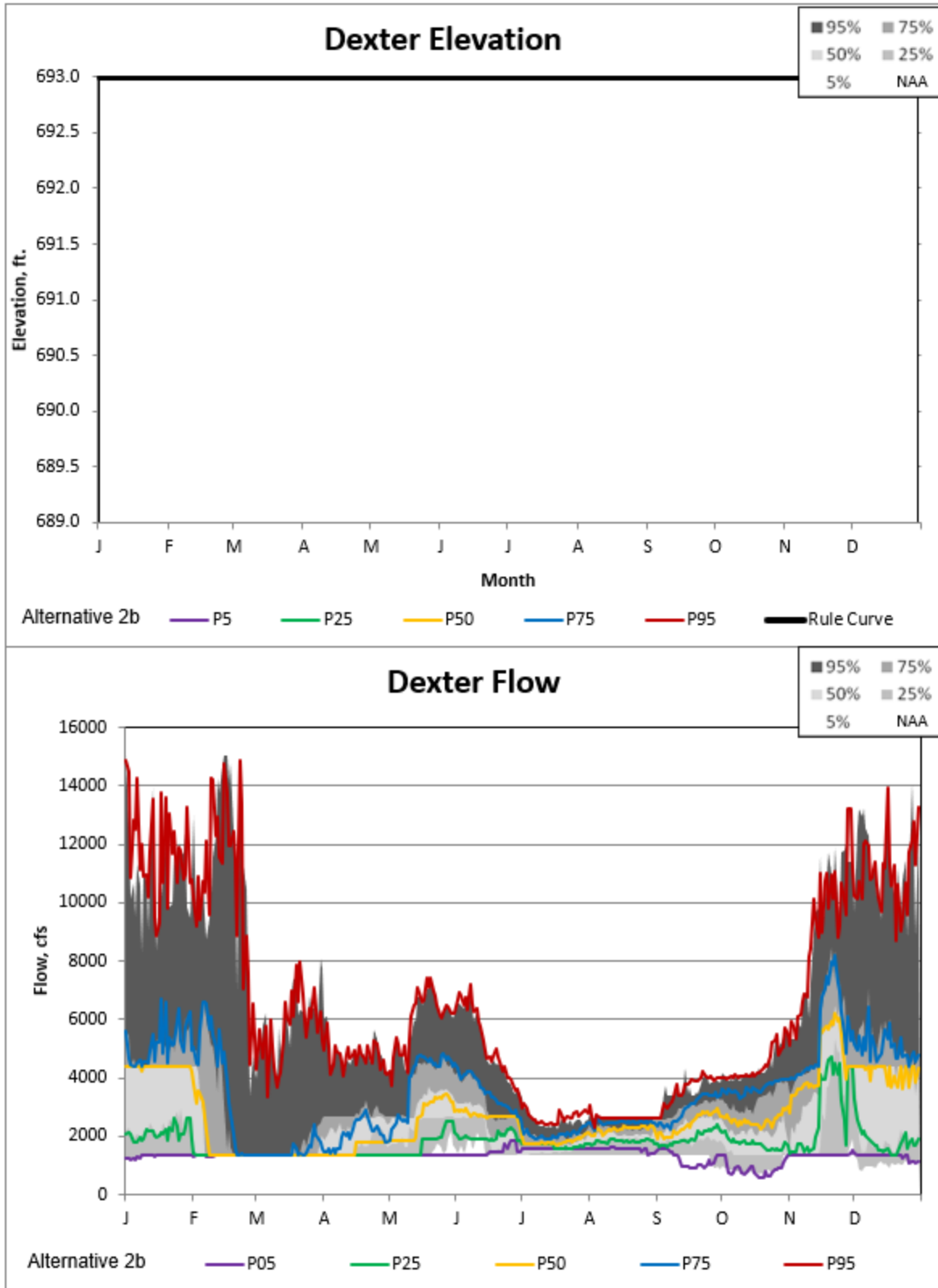

Figure 5-53. Dexter Alternative 2B Non-exceedance Plot.

Willamette Valley System Operations and Maintenance
Environmental Impact Statement

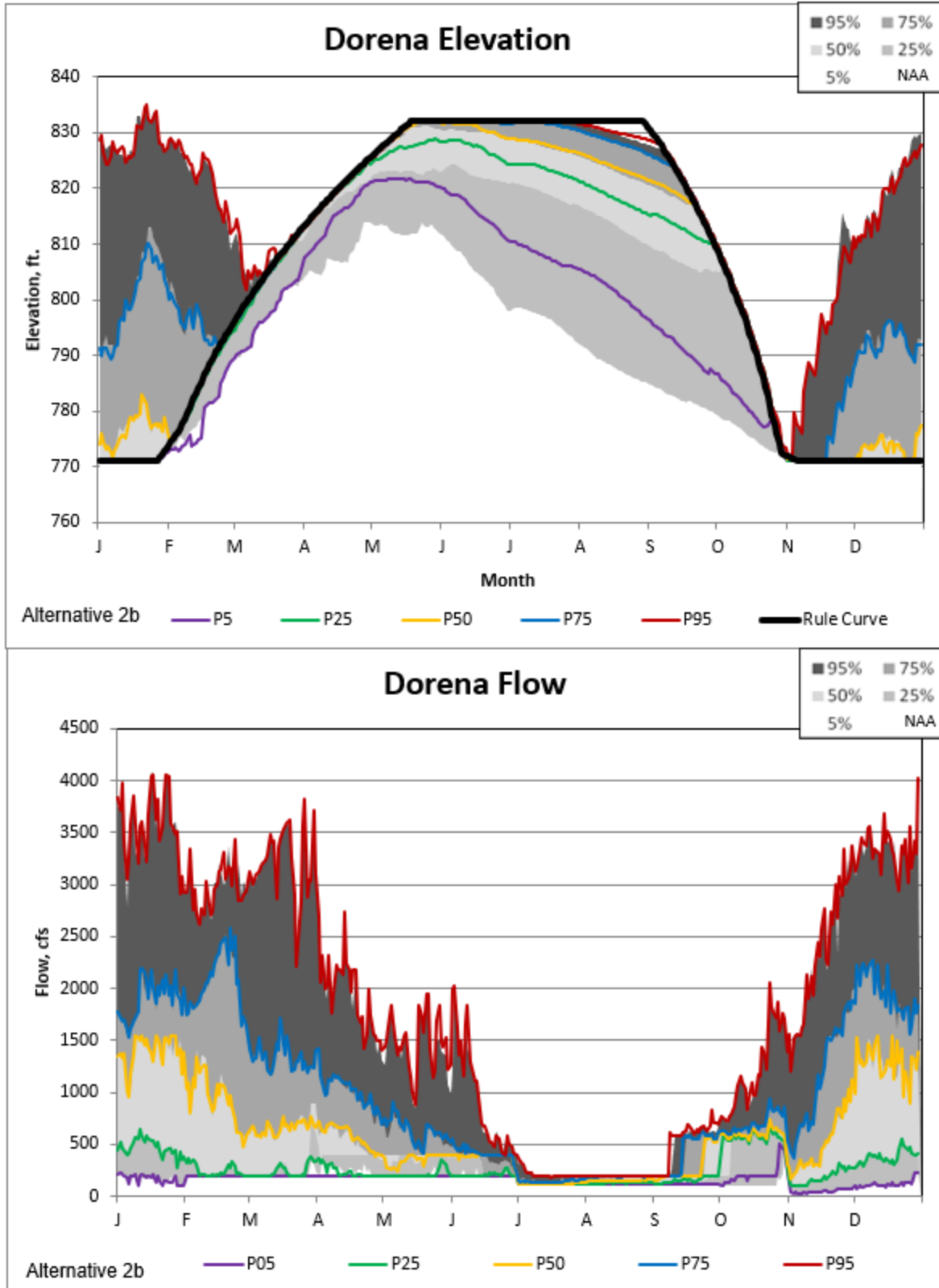

Figure 5-54. Dorena Alternative 2B Non-exceedance Plot.

Willamette Valley System Operations and Maintenance
Environmental Impact Statement

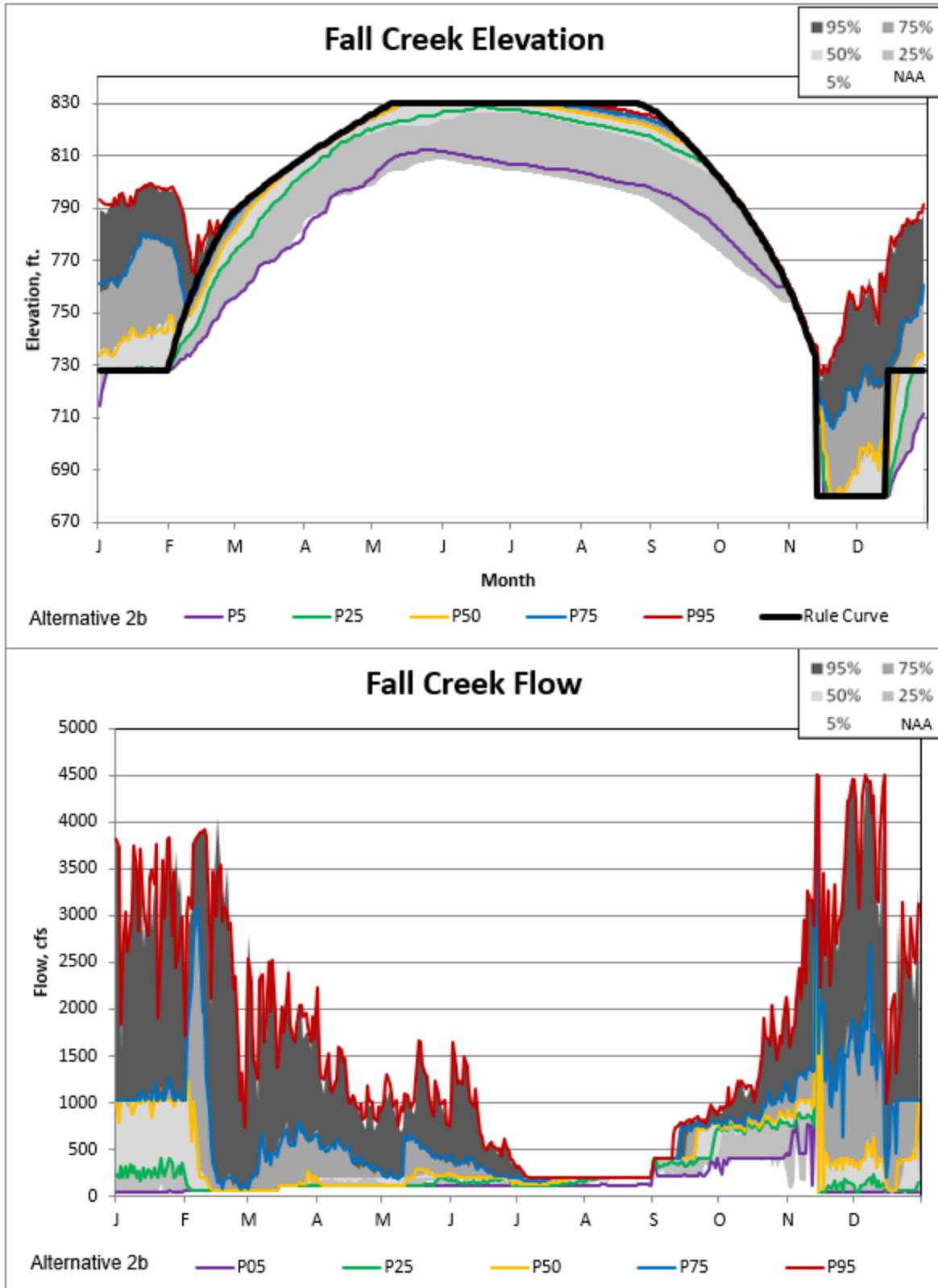

Figure 5-55. Fall Creek Alternative 2B Non-exceedance Plot.

Willamette Valley System Operations and Maintenance
Environmental Impact Statement

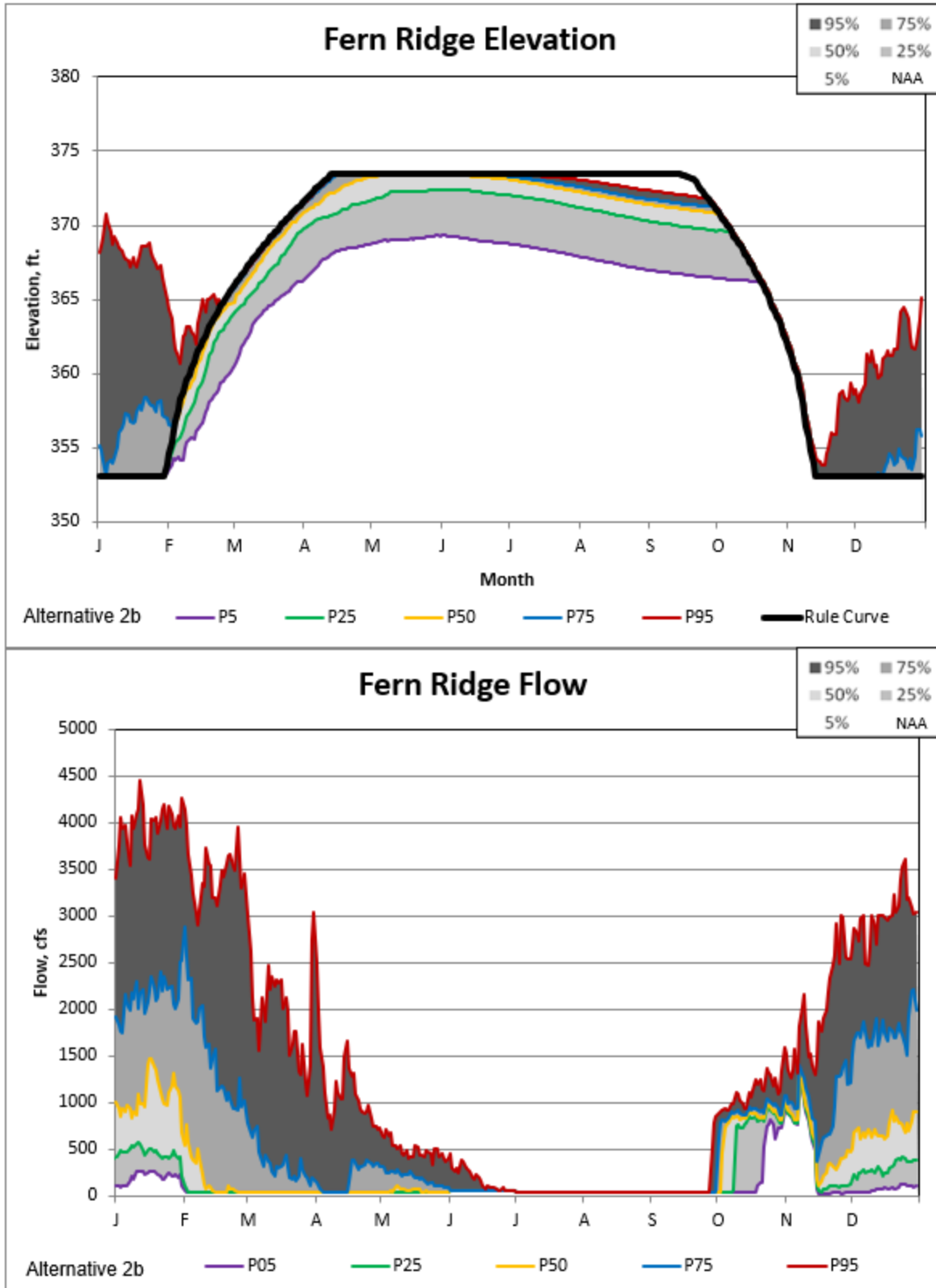

Figure 5-56. Fern Ridge Alternative 2B Non-exceedance Plot.

Willamette Valley System Operations and Maintenance
Environmental Impact Statement

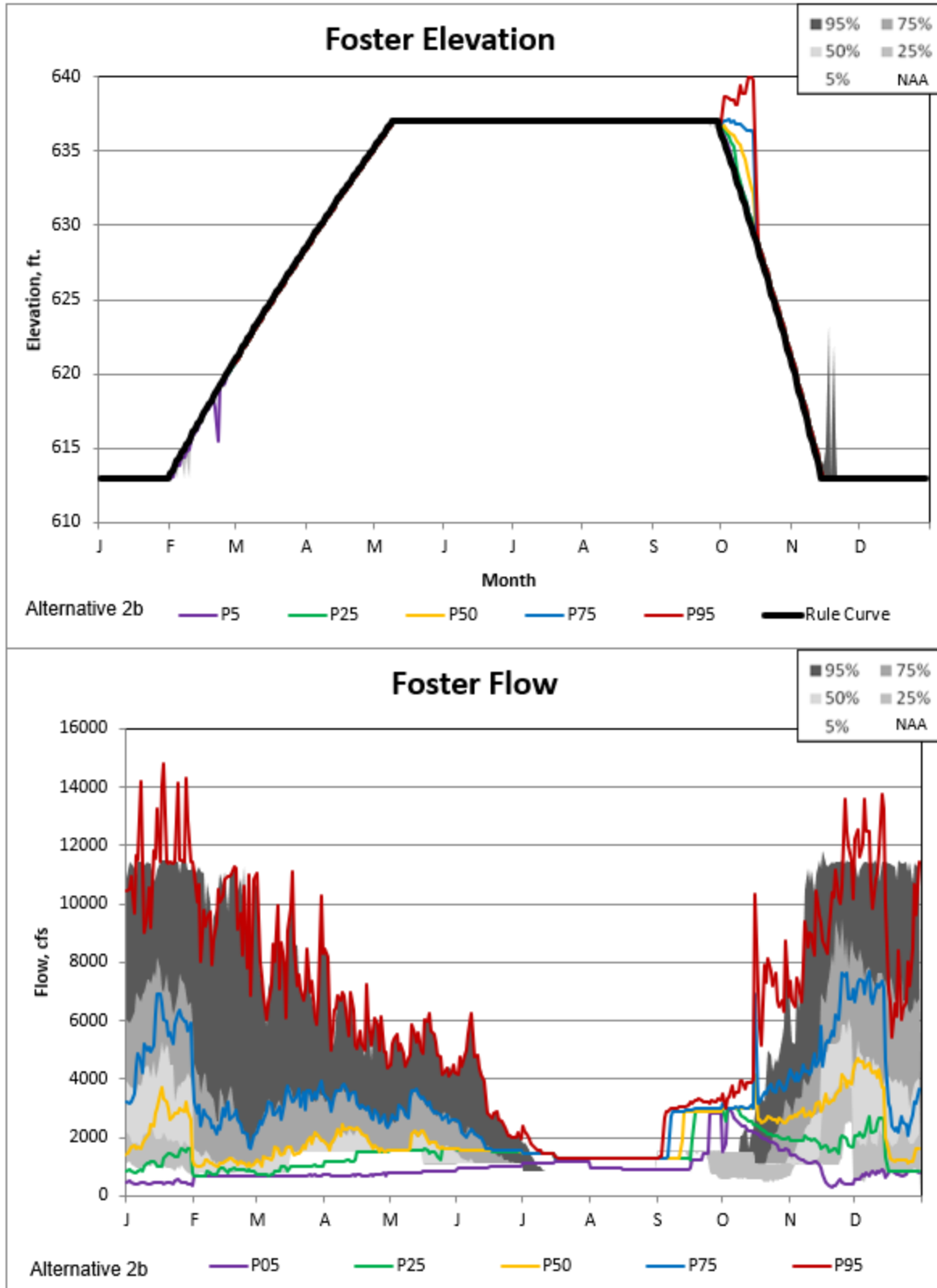

Figure 5-57. Foster Alternative 2B Non-exceedance Plot.

Willamette Valley System Operations and Maintenance
Environmental Impact Statement

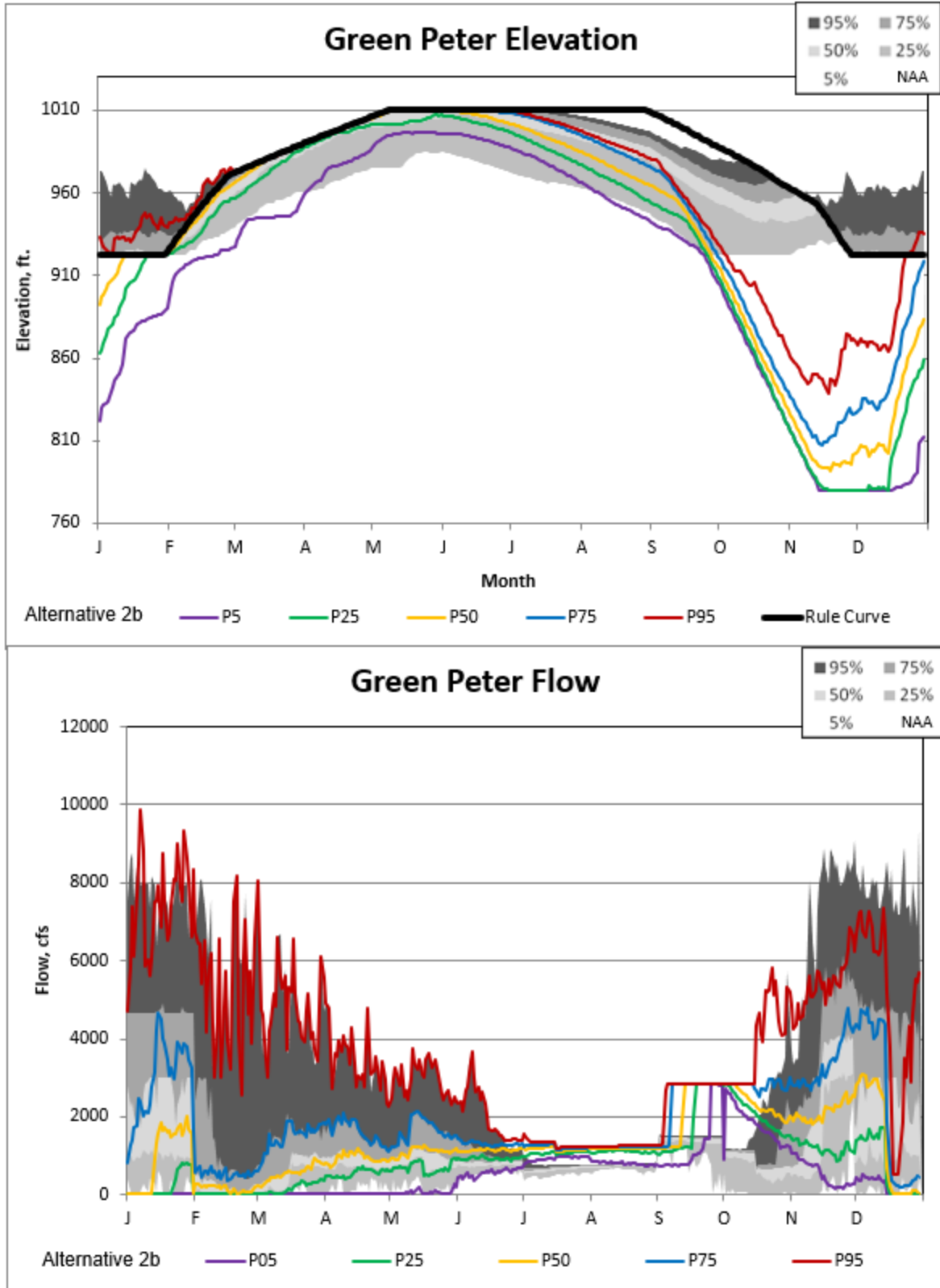

Figure 5-58. Green Peter Alternative 2B Non-exceedance Plot.

Willamette Valley System Operations and Maintenance
Environmental Impact Statement

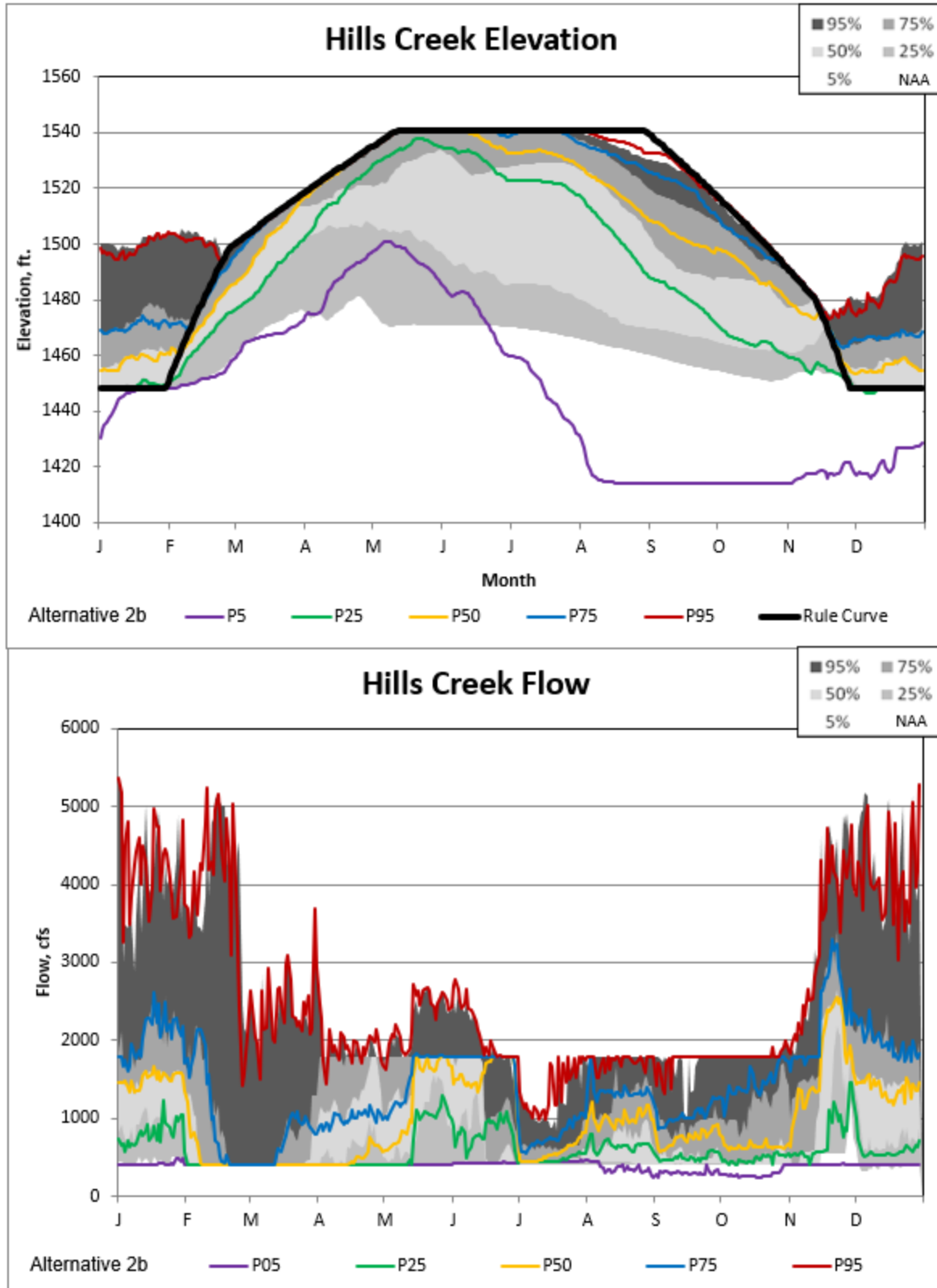

Figure 5-59. Hills Creek Alternative 2B Non-exceedance Plot.

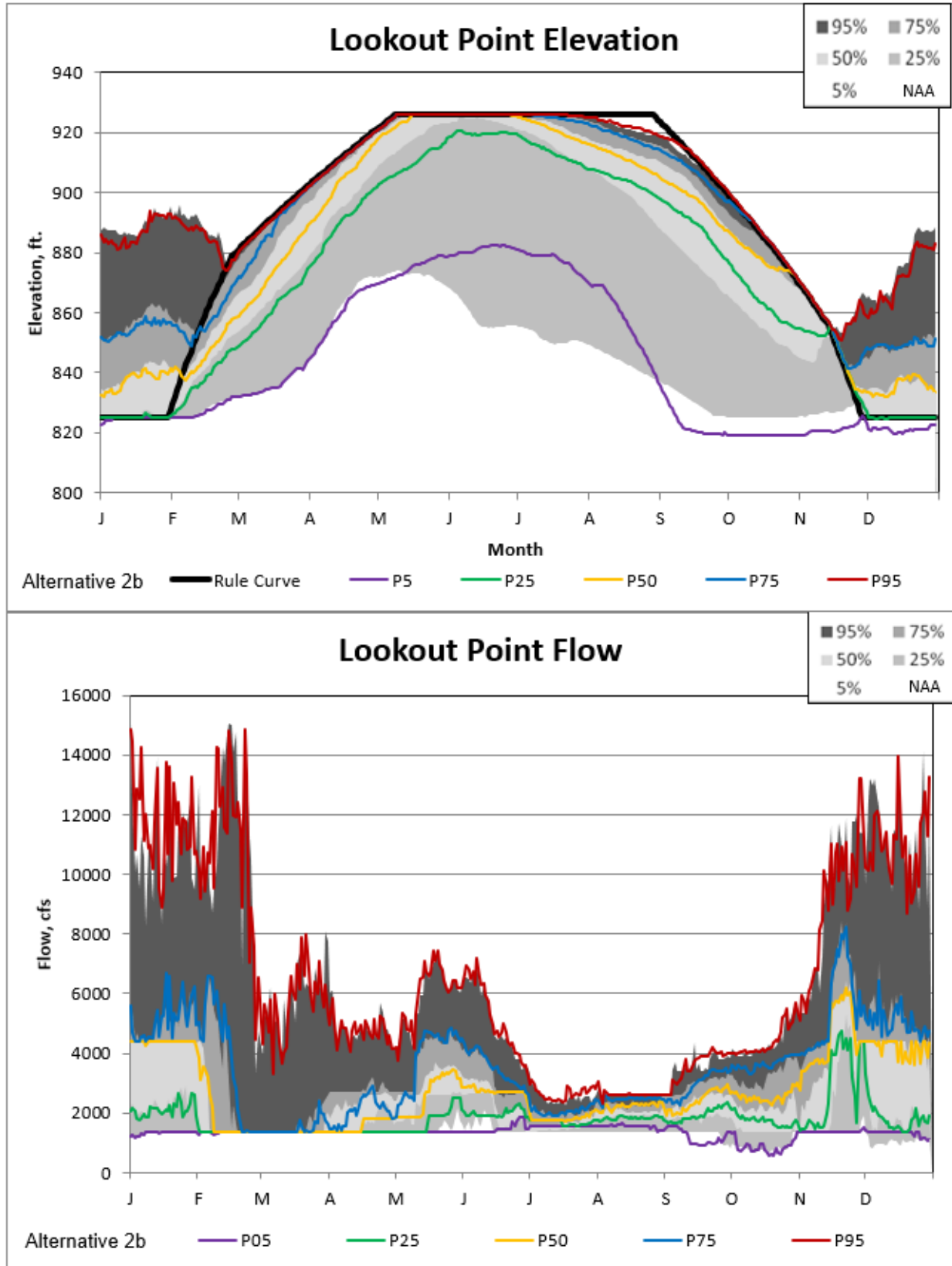

Figure 5-60. Lookout Point Alternative 2B Non-exceedance Plot.

Willamette Valley System Operations and Maintenance
Environmental Impact Statement

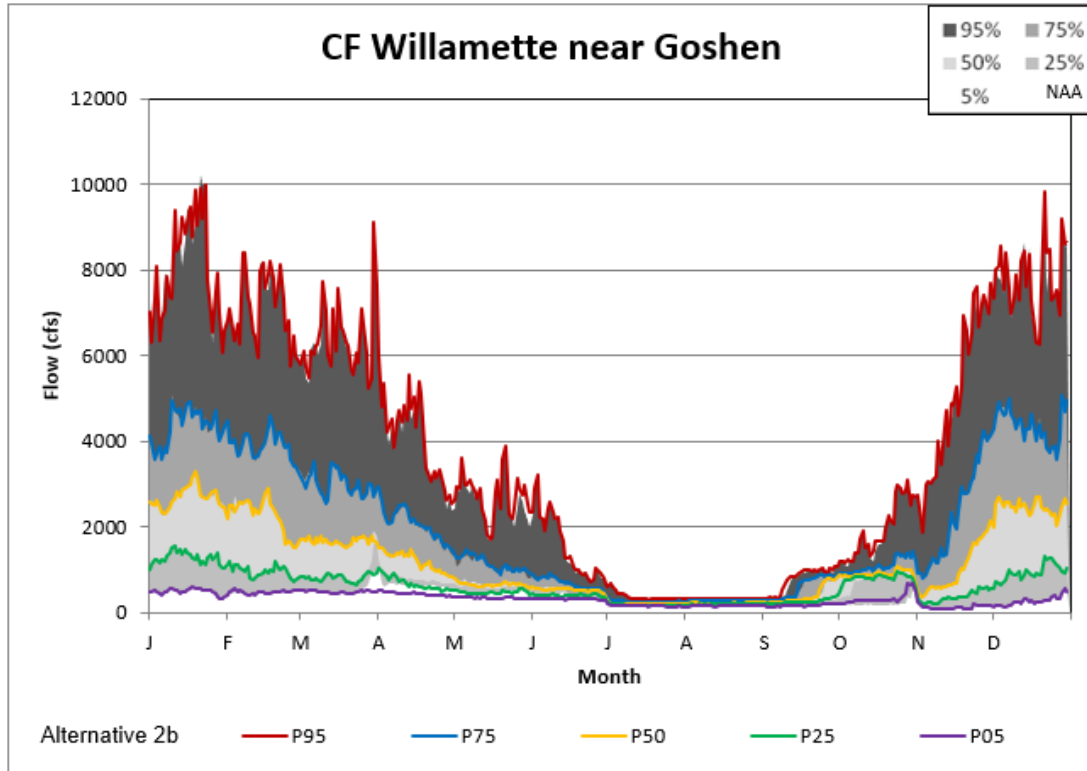

Figure 5-61. Goshen Alternative 2B Non-exceedance Plot.

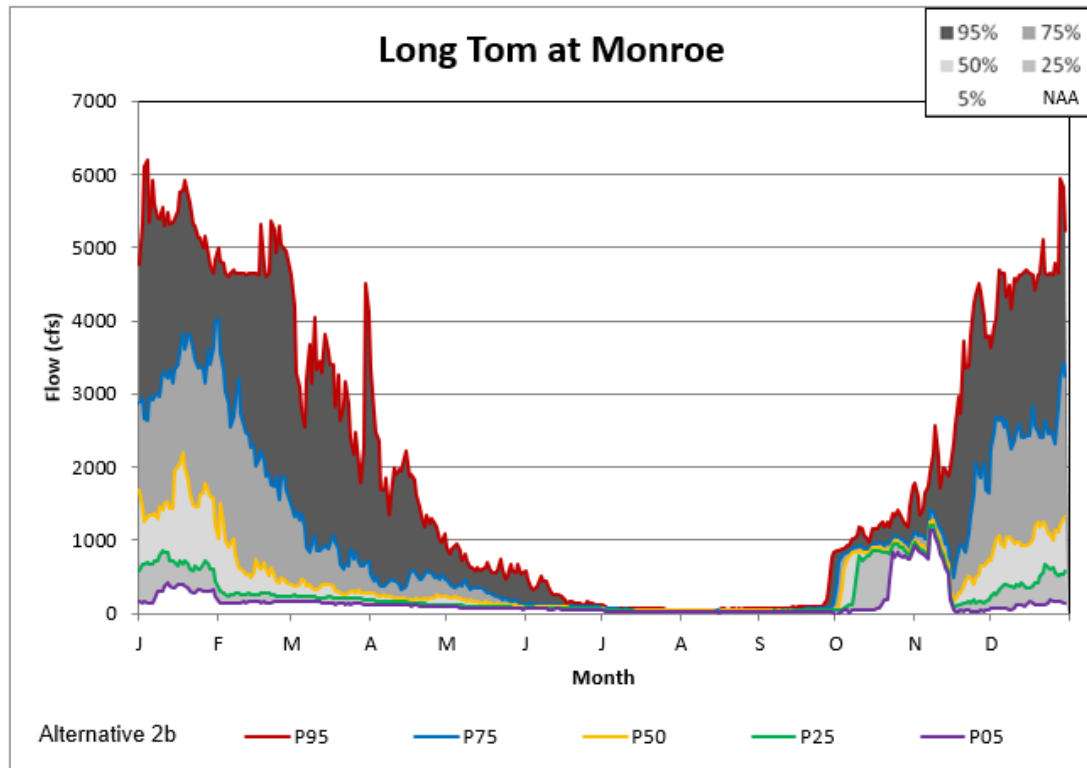

Figure 5-62. Monroe Alternative 2B Non-exceedance Plot.

Willamette Valley System Operations and Maintenance
Environmental Impact Statement

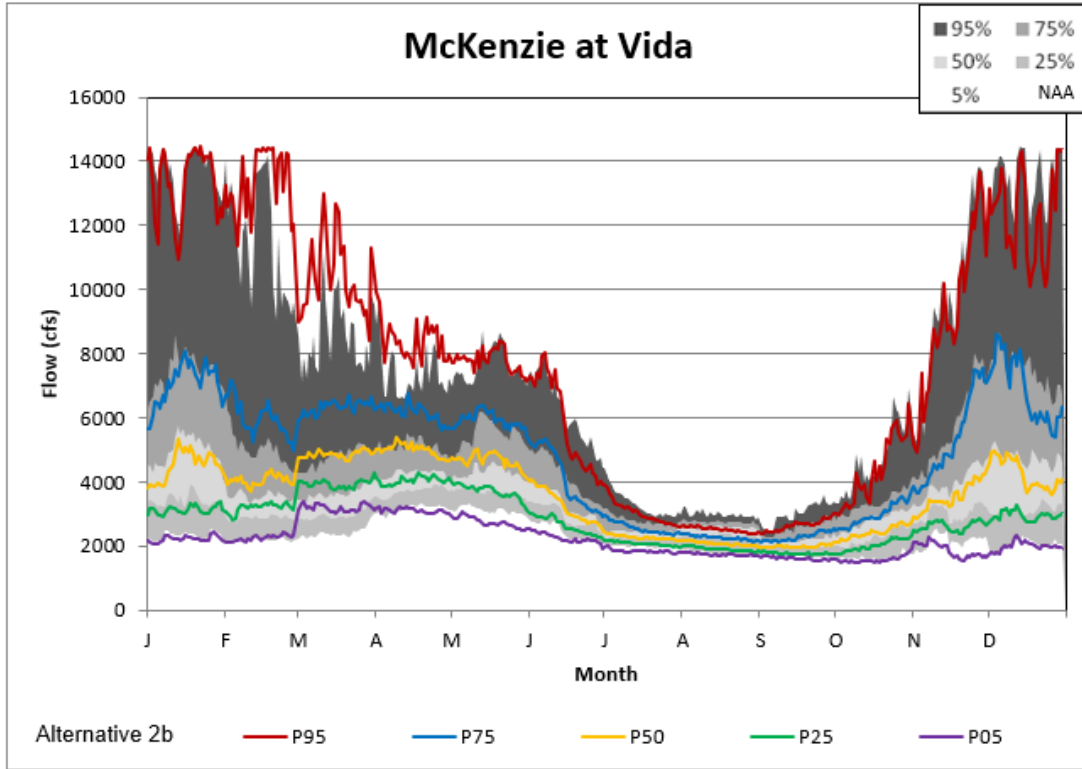

Figure 5-63. Vida Alternative 2B Non-exceedance Plot.

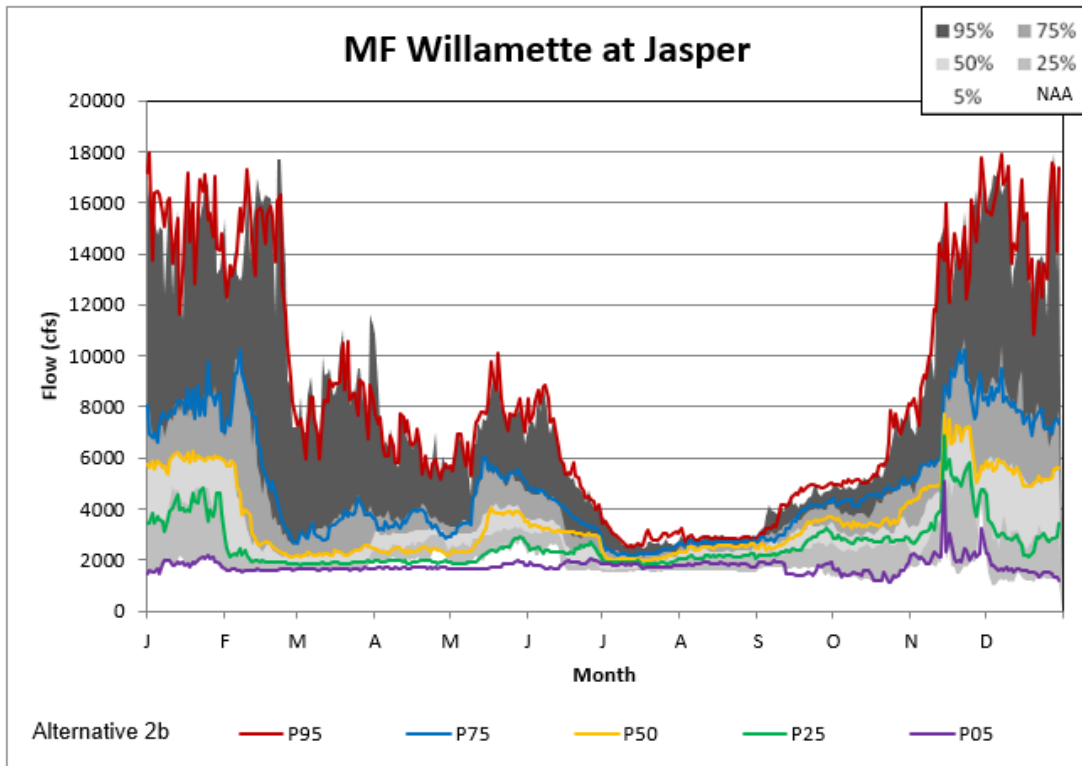

Figure 5-64. Jasper Alternative 2B Non-exceedance Plot.

Willamette Valley System Operations and Maintenance
Environmental Impact Statement

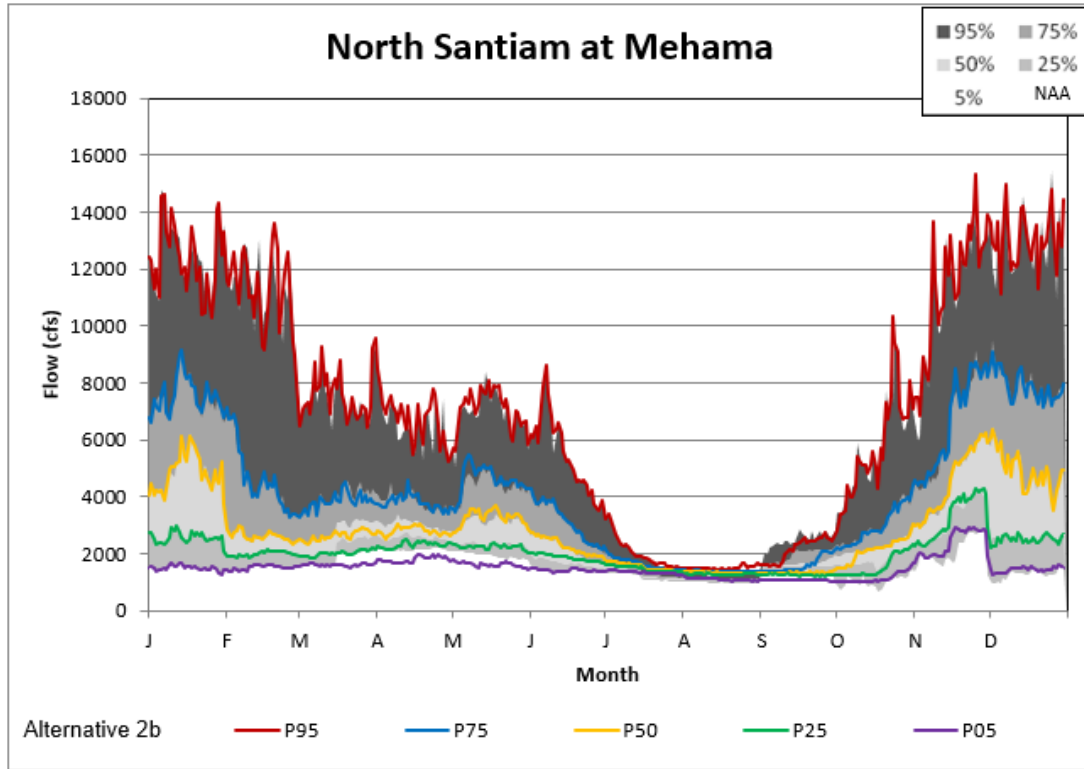

Figure 5-65. Mehama Alternative 2B Non-exceedance Plot.

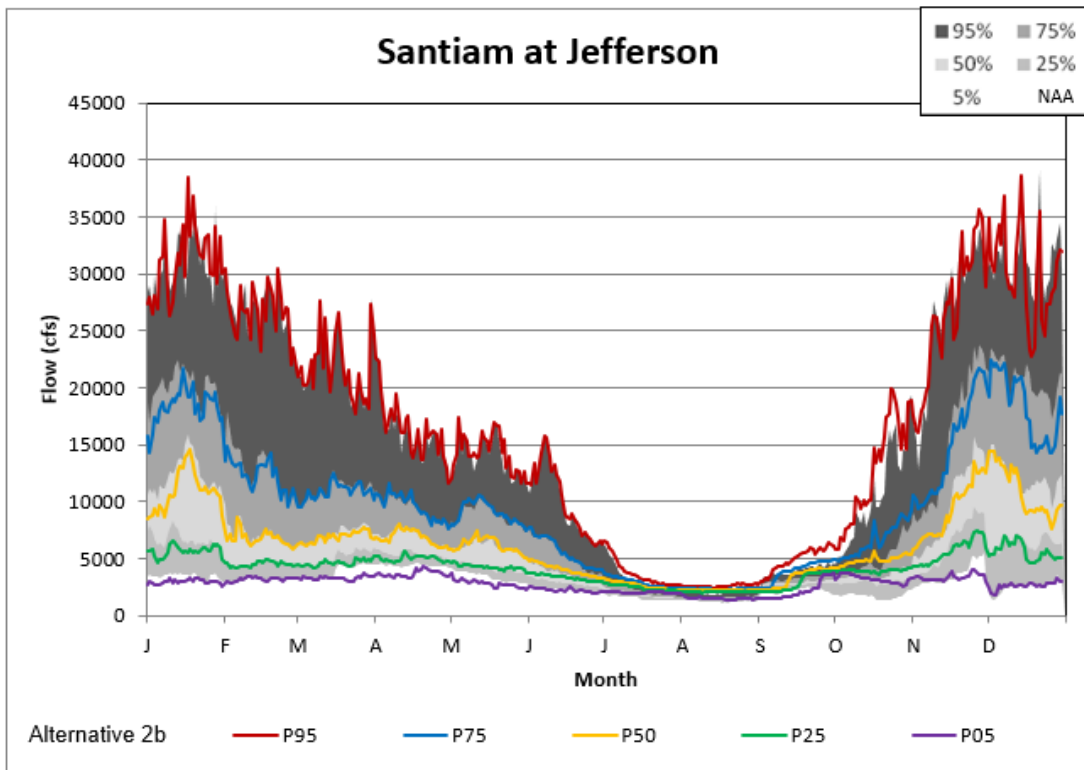

Figure 5-66. Jefferson Alternative 2B Non-exceedance Plot.

Willamette Valley System Operations and Maintenance
Environmental Impact Statement

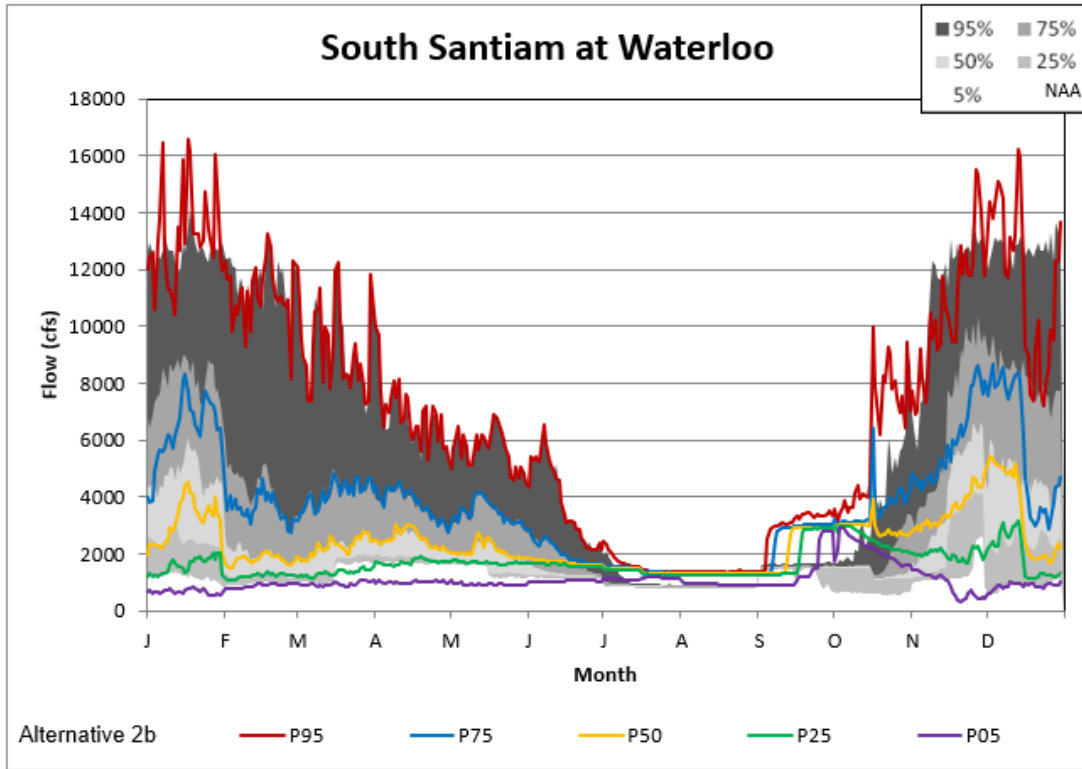

Figure 5-67. Waterloo Alternative 2B Non-exceedance Plot.

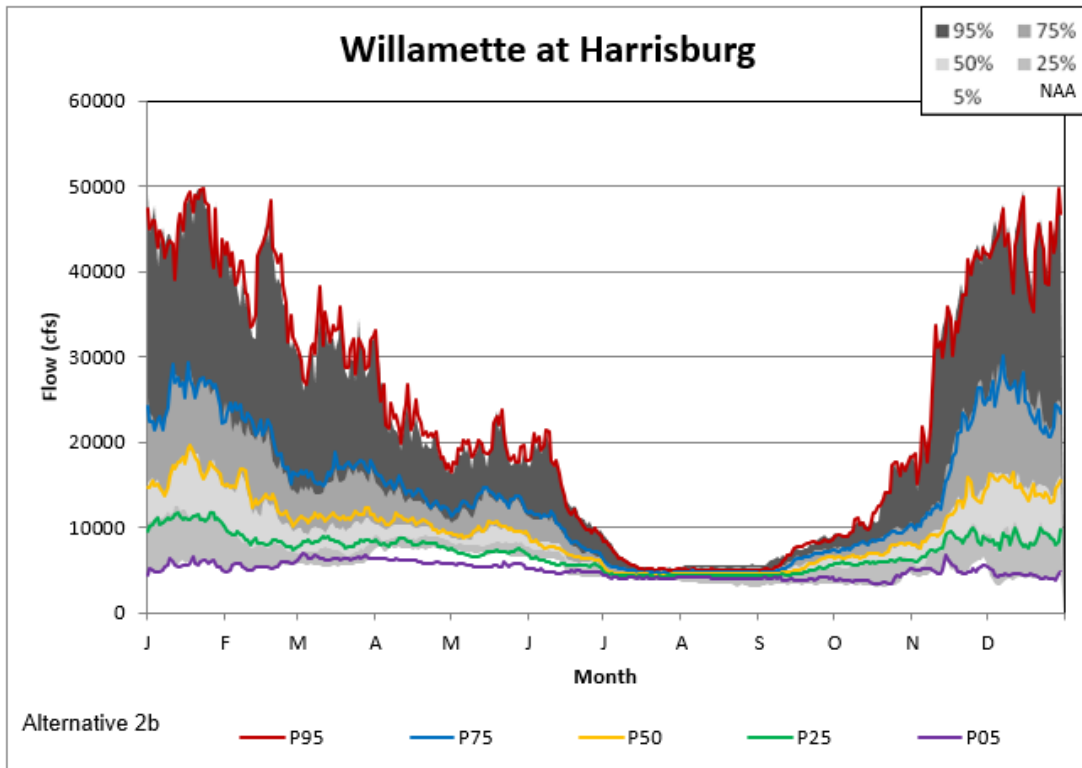

Figure 5-68. Harrisburg Alternative 2B Non-exceedance Plot.

Willamette Valley System Operations and Maintenance
Environmental Impact Statement

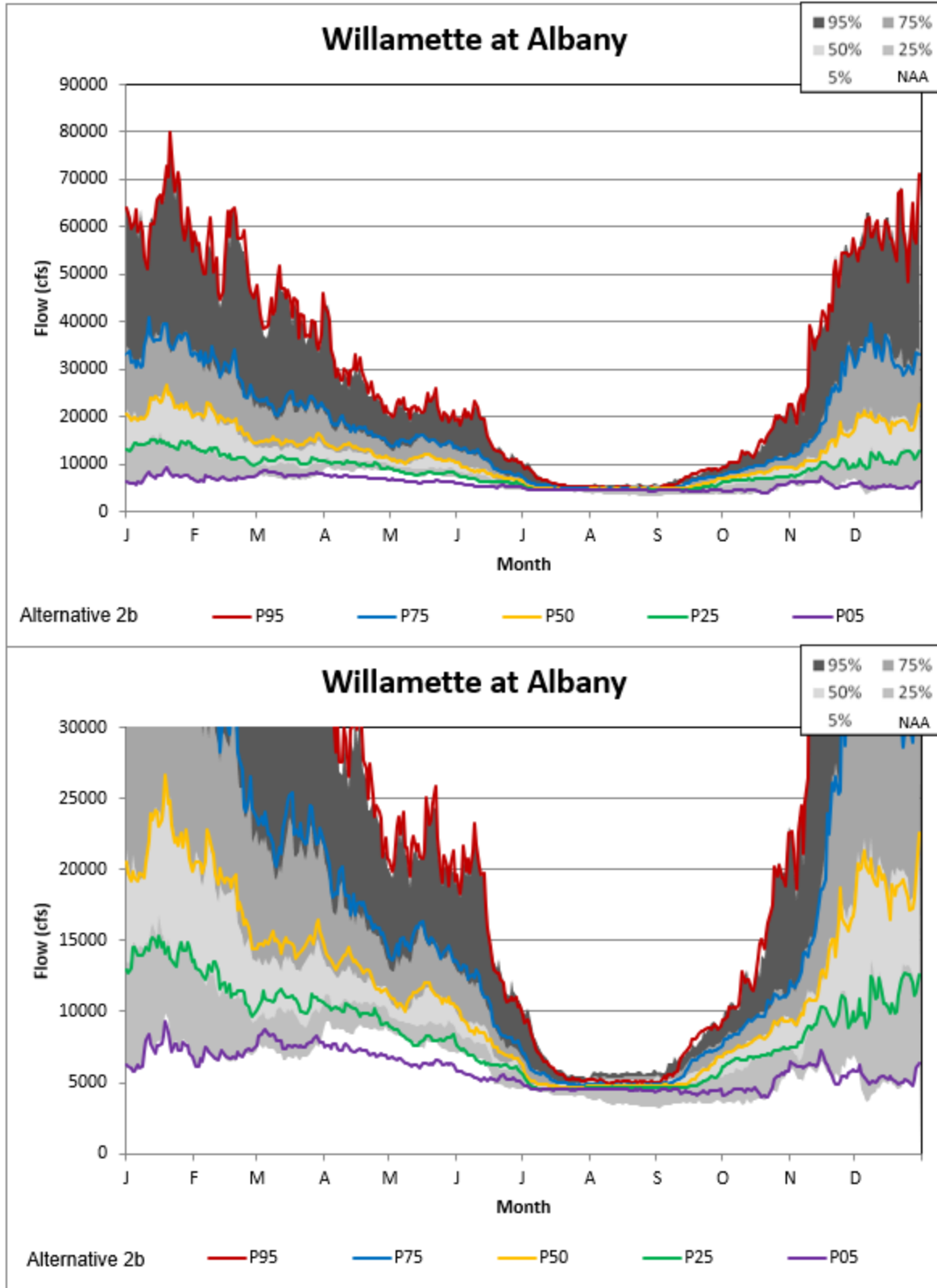

Figure 5-69. Albany Alternative 2B Non-exceedance Plot.

Willamette Valley System Operations and Maintenance
Environmental Impact Statement

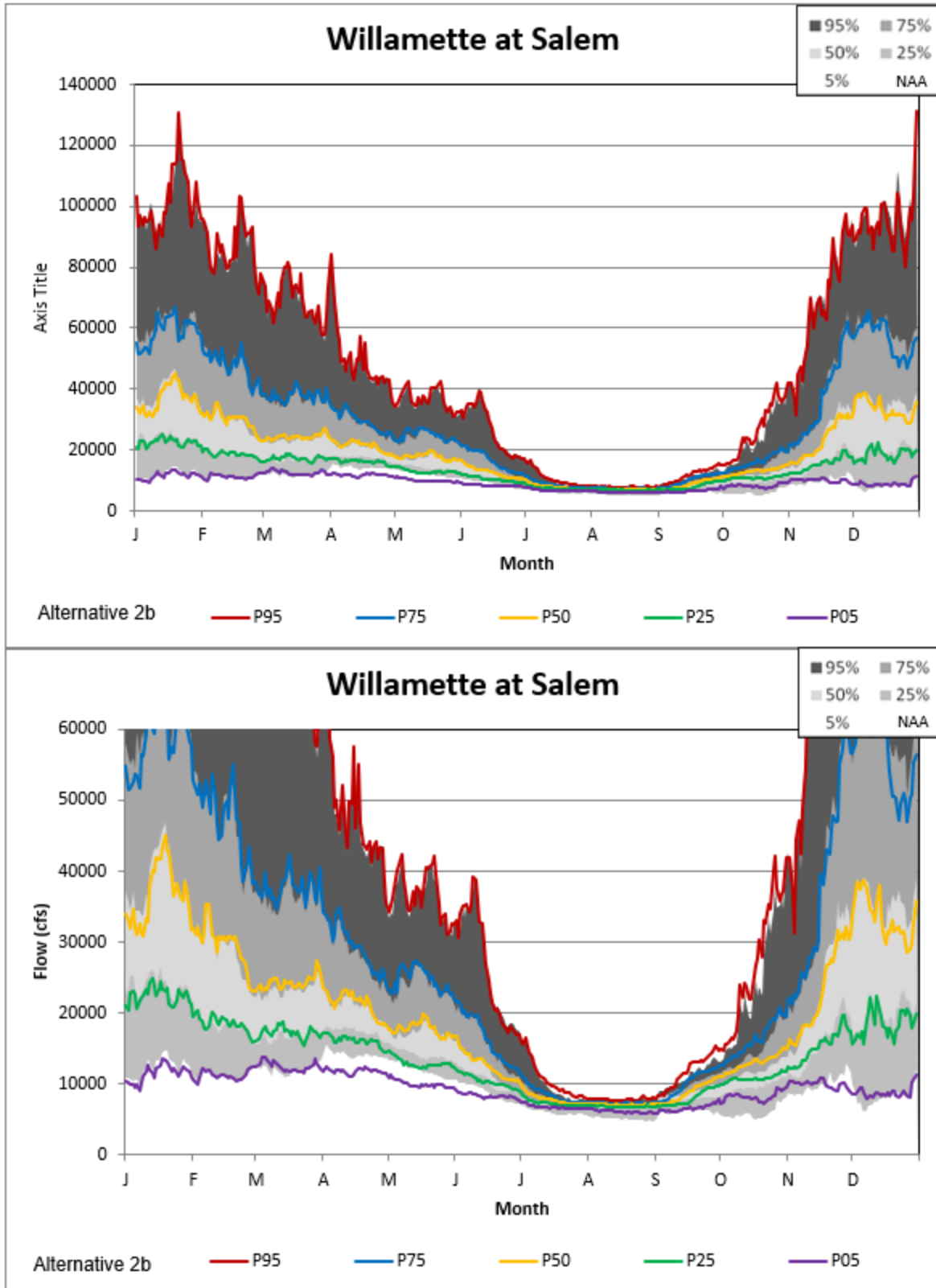

Figure 5-70. Salem Alternative 2B Non-exceedance Plot.

5.4 Alternative 3A

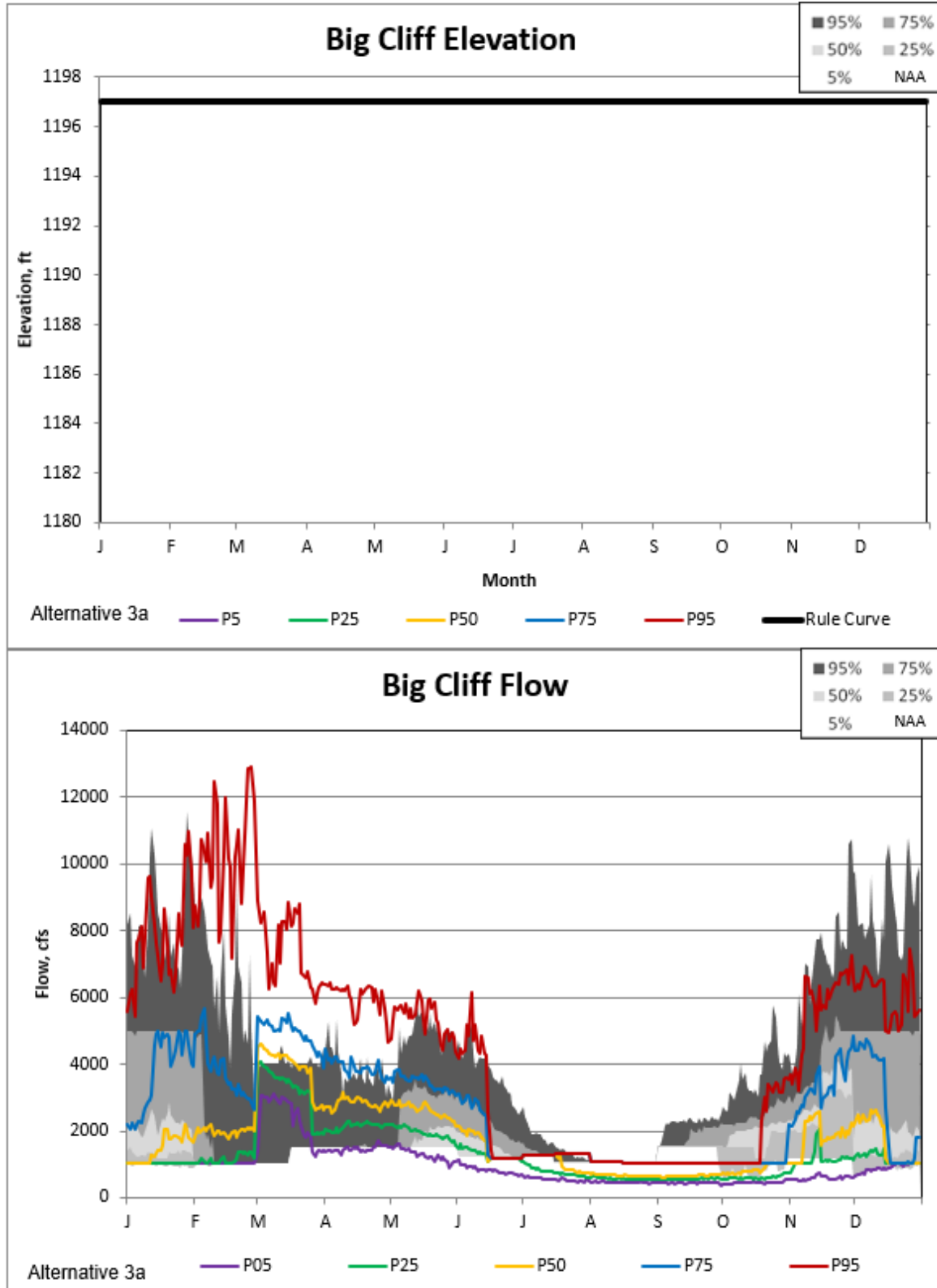

Figure 5-71. Big Cliff Alternative 3A Non-exceedance Plot.

Willamette Valley System Operations and Maintenance
Environmental Impact Statement

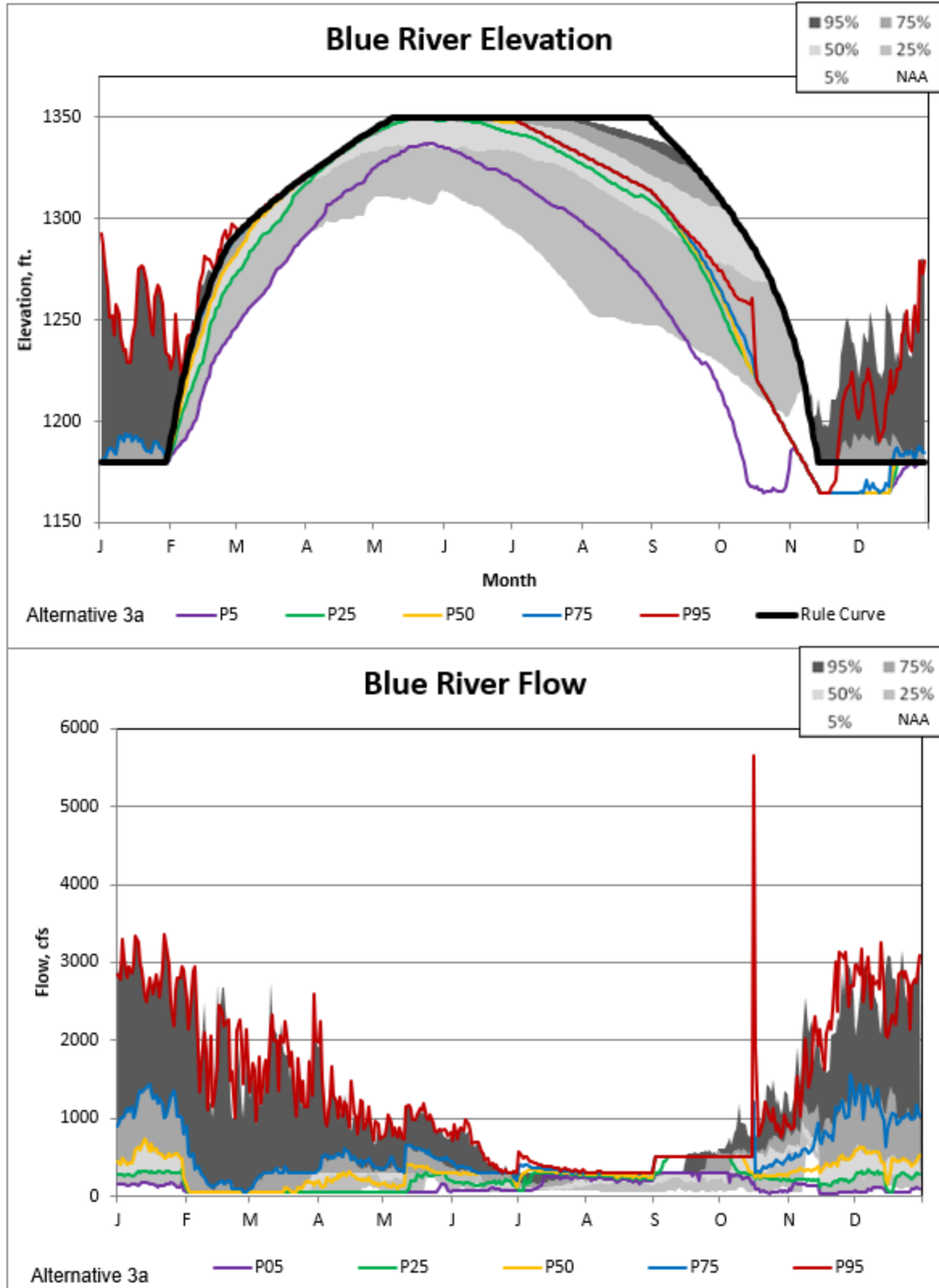

Figure 5-72. Blue River Alternative 3A Non-exceedance Plot.

Willamette Valley System Operations and Maintenance
Environmental Impact Statement

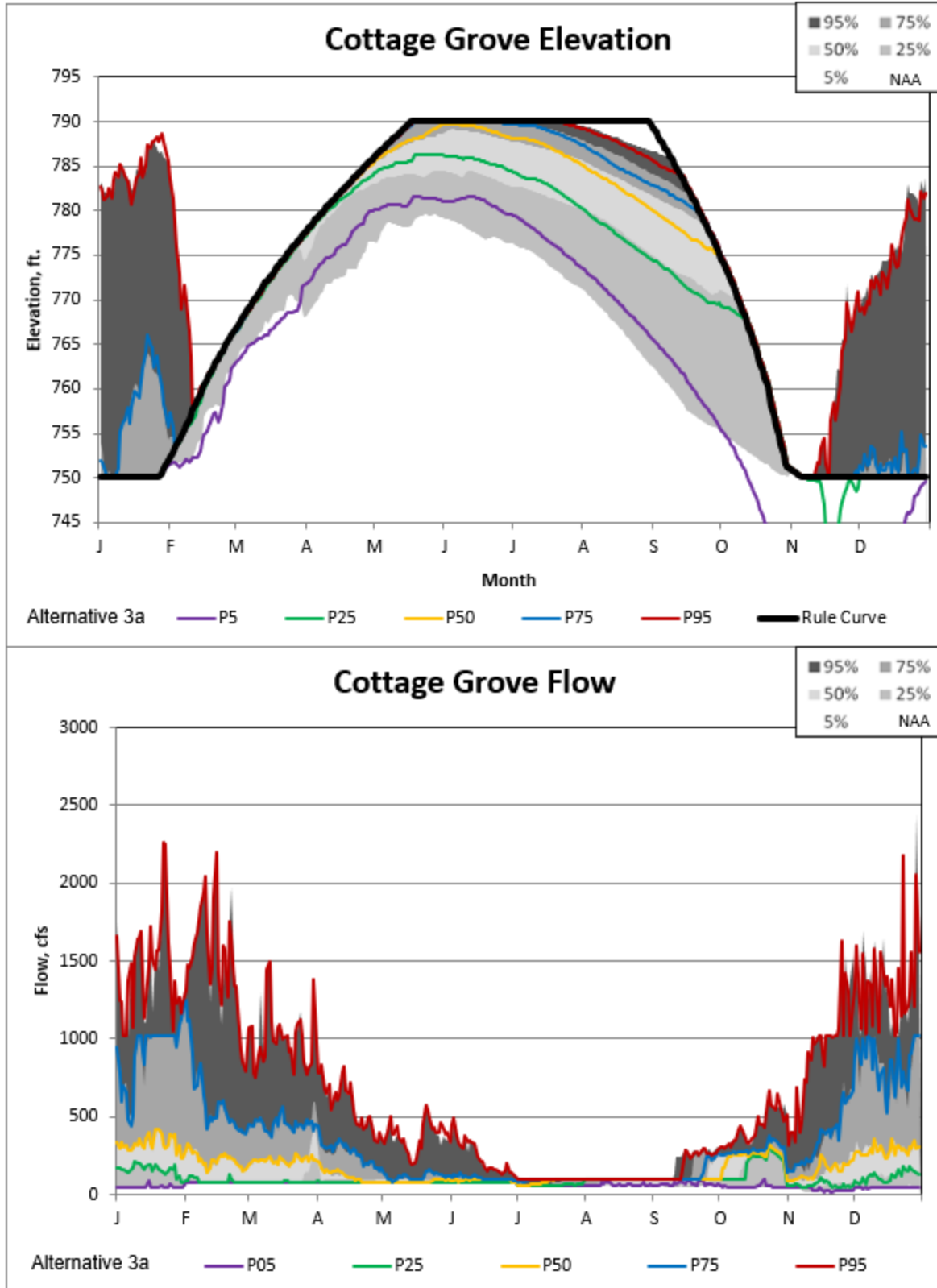

Figure 5-73. Cottage Grove Alternative 3A Non-exceedance Plot.

Willamette Valley System Operations and Maintenance
 Environmental Impact Statement

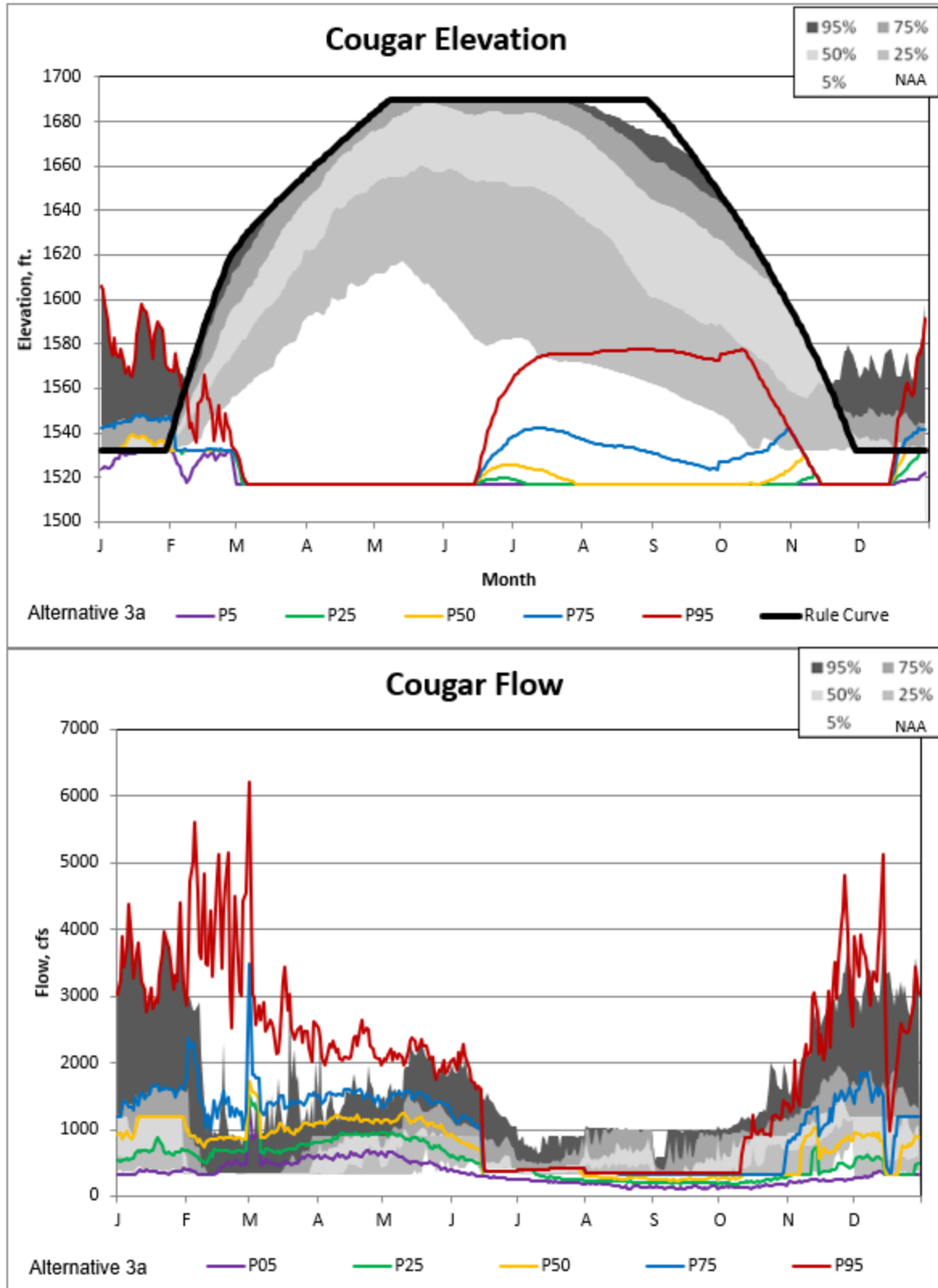

Figure 5-74. Cougar Alternative 3A Non-exceedance Plot.

Willamette Valley System Operations and Maintenance
Environmental Impact Statement

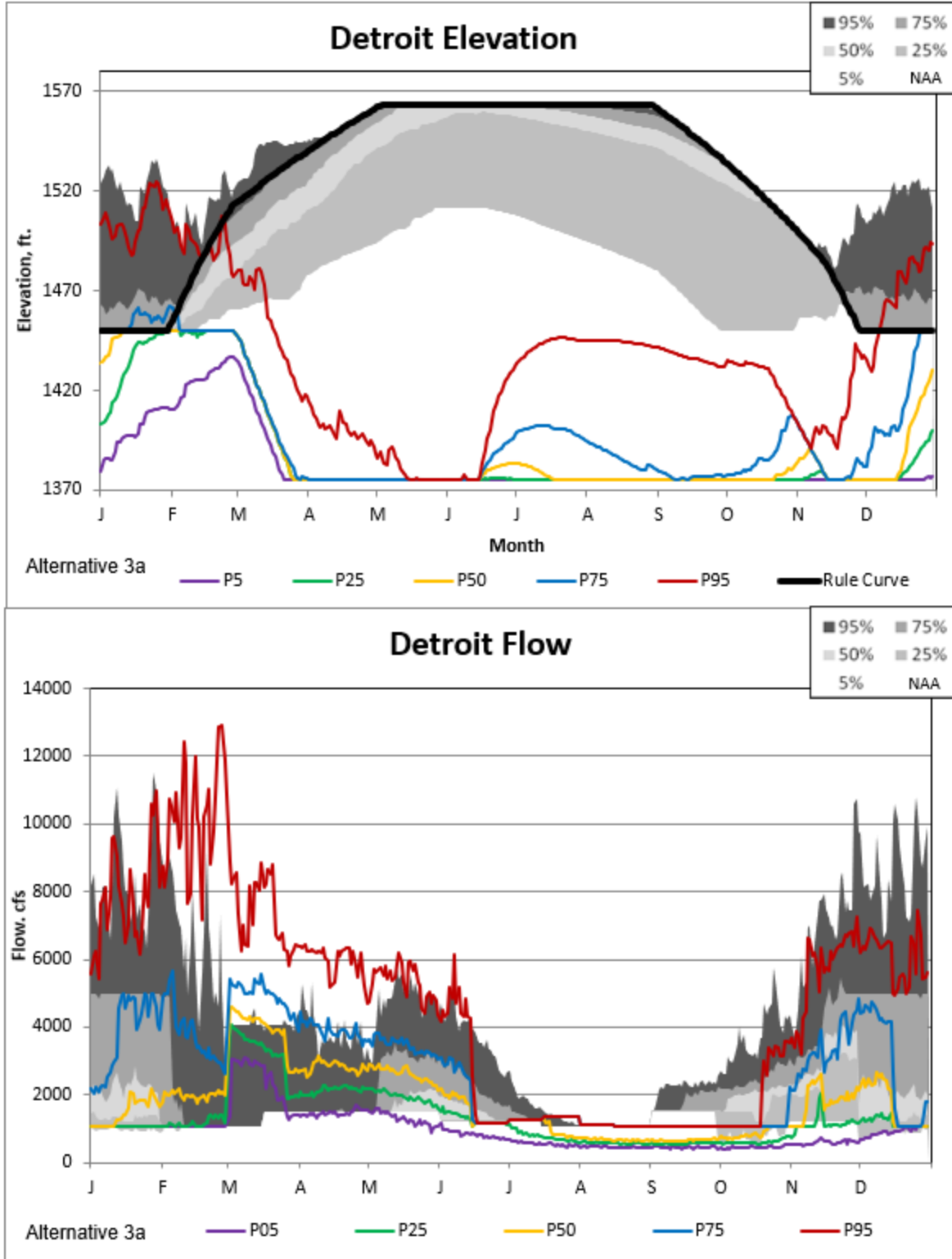

Figure 5-75. Detroit Alternative 3A Non-exceedance Plot.

Willamette Valley System Operations and Maintenance
Environmental Impact Statement

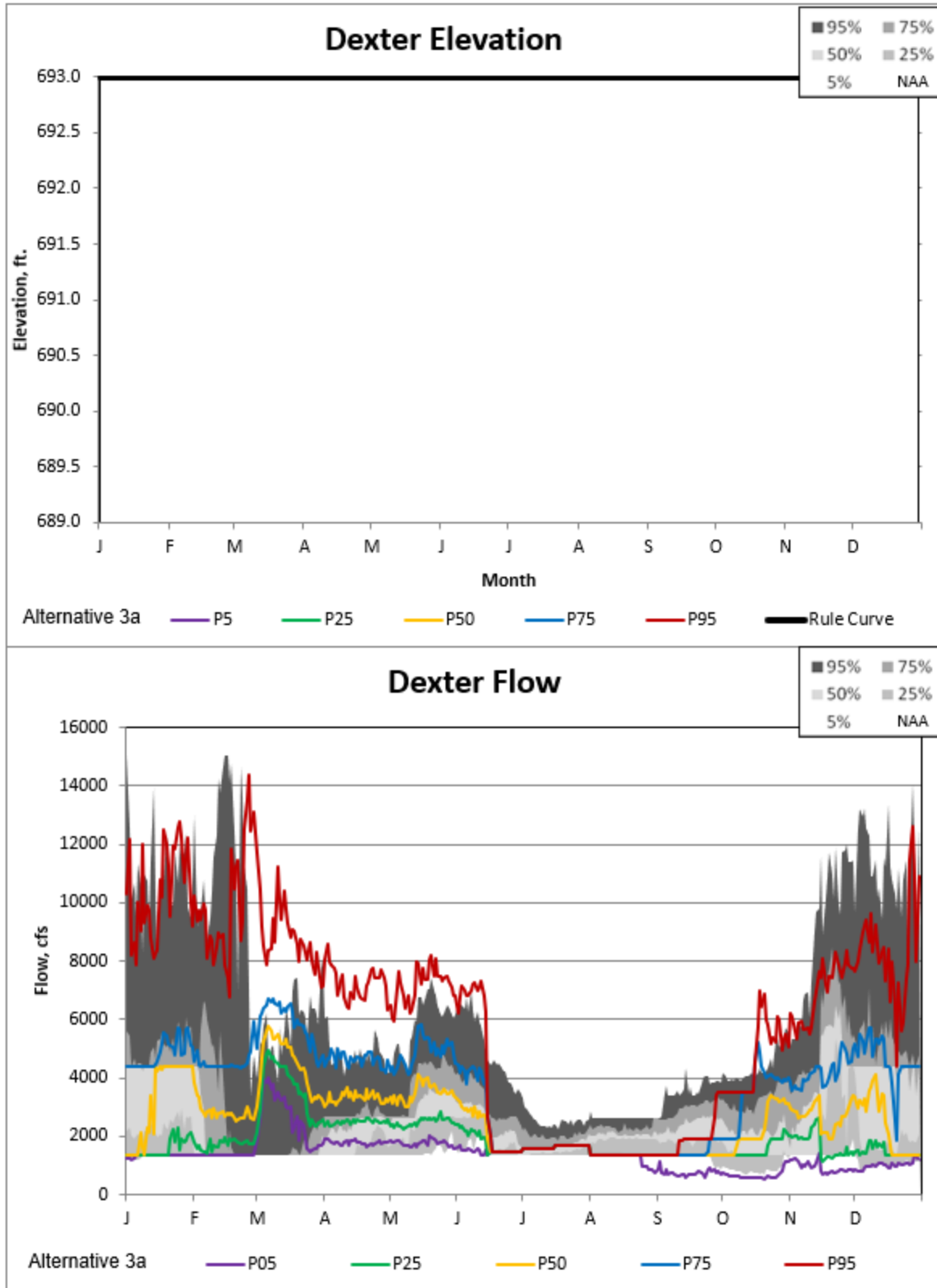

Figure 5-76. Dexter Alternative 3A Non-exceedance Plot.

Willamette Valley System Operations and Maintenance
Environmental Impact Statement

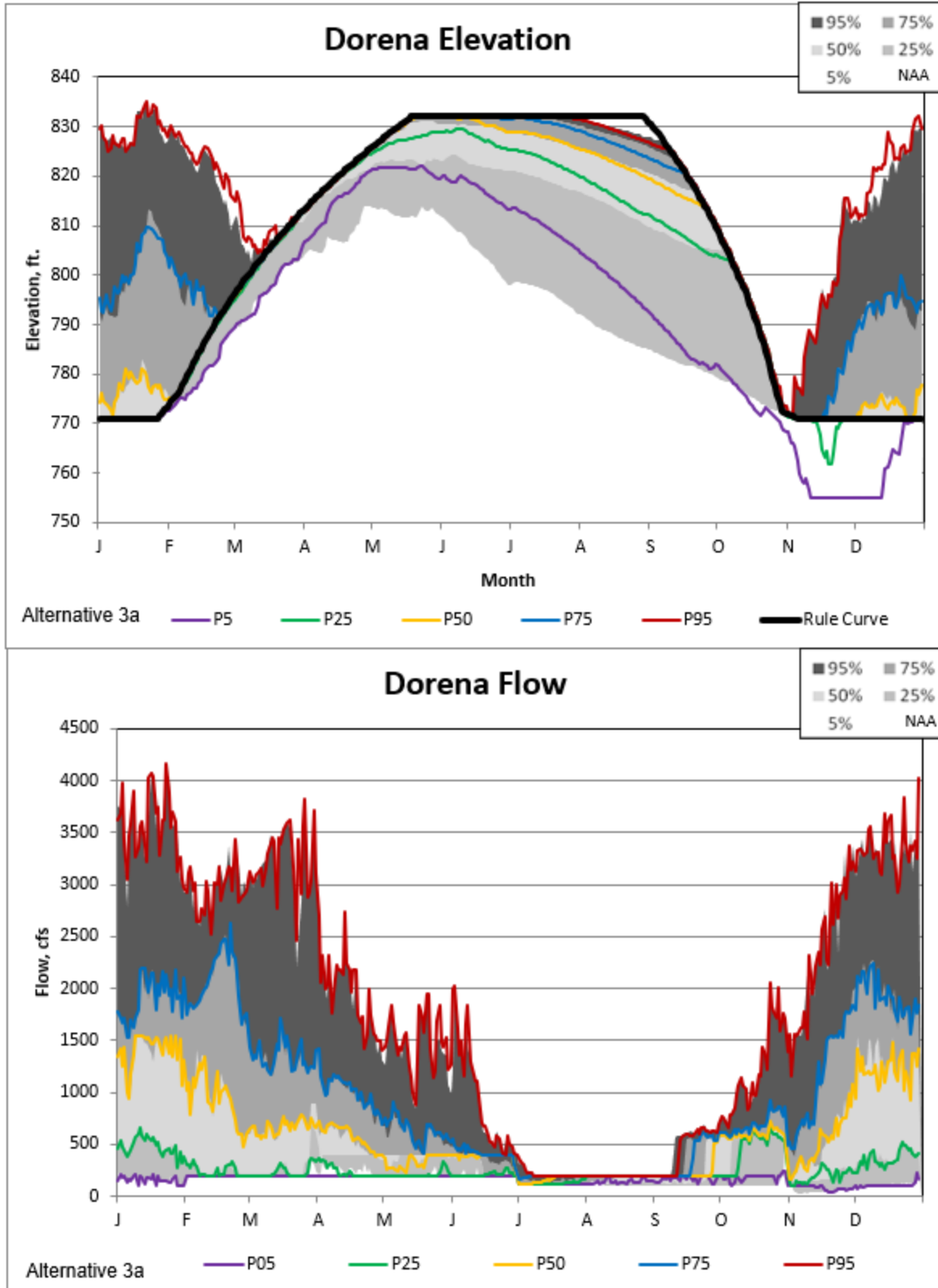

Figure 5-77. Dorena Alternative 3A Non-exceedance Plot.

Willamette Valley System Operations and Maintenance
Environmental Impact Statement

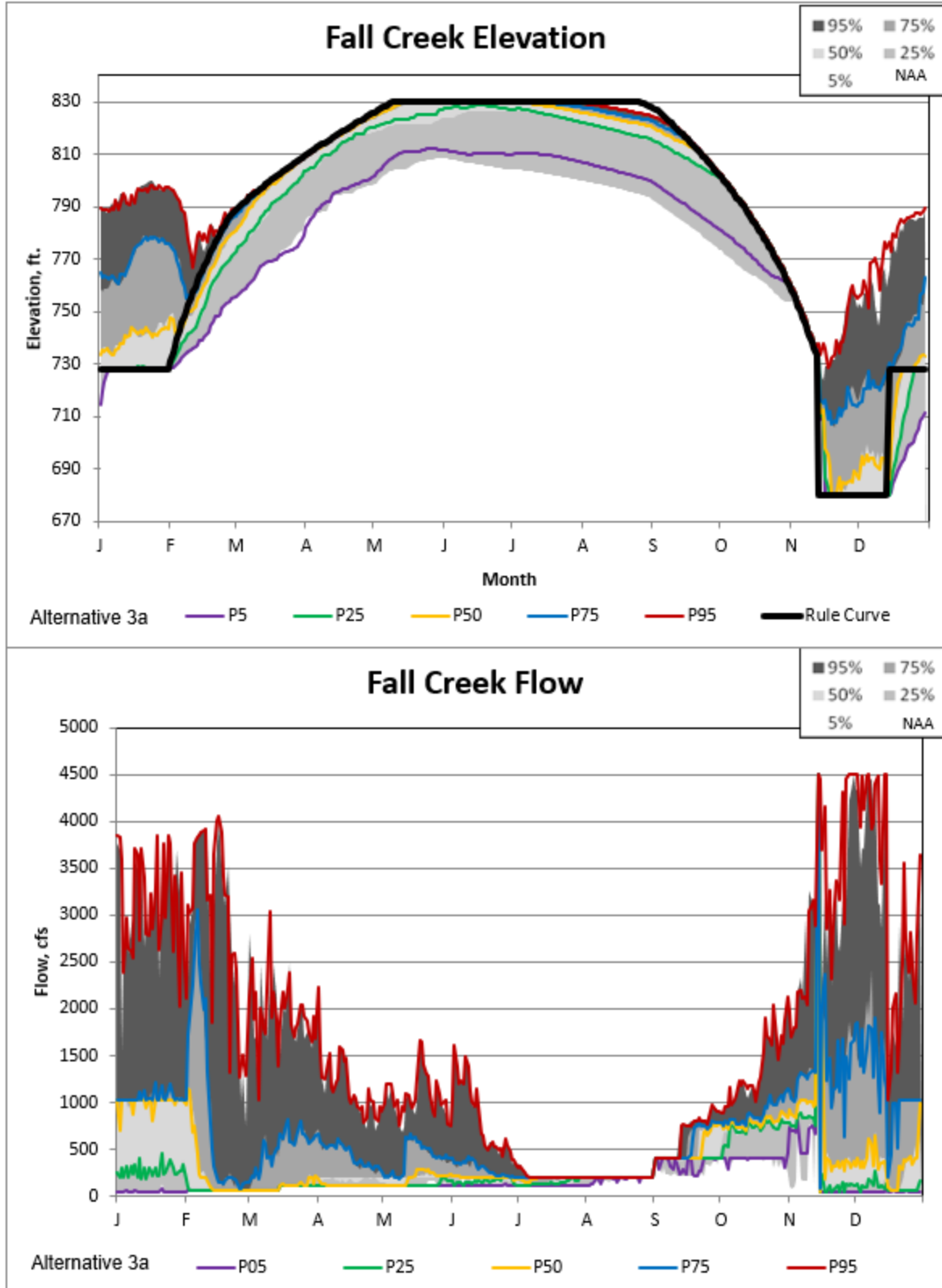

Figure 5-78. Fall Creek Alternative 3A Non-exceedance Plot.

Willamette Valley System Operations and Maintenance
Environmental Impact Statement

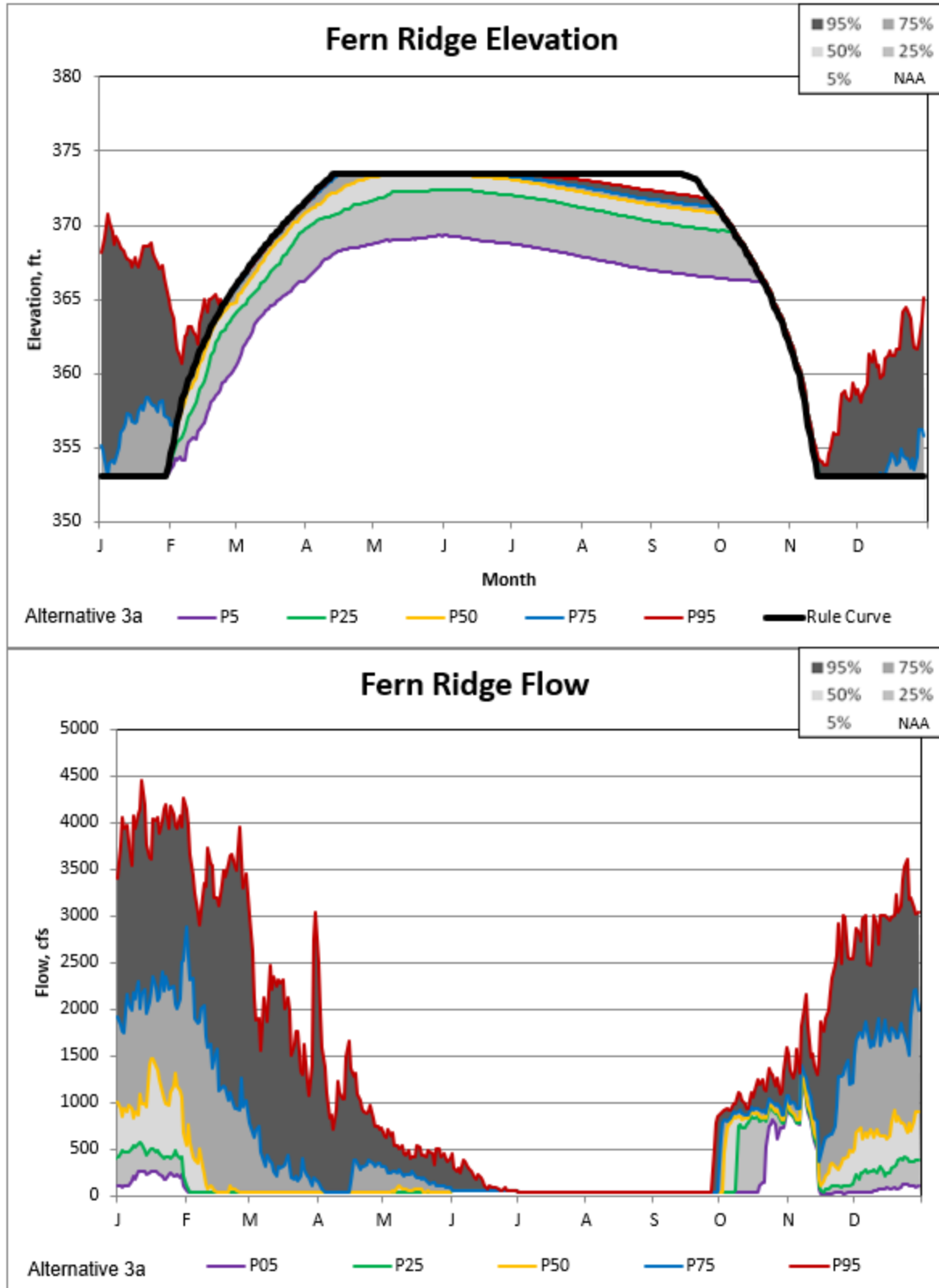

Figure 5-79. Fern Ridge Alternative 3A Non-exceedance Plot.

Willamette Valley System Operations and Maintenance
Environmental Impact Statement

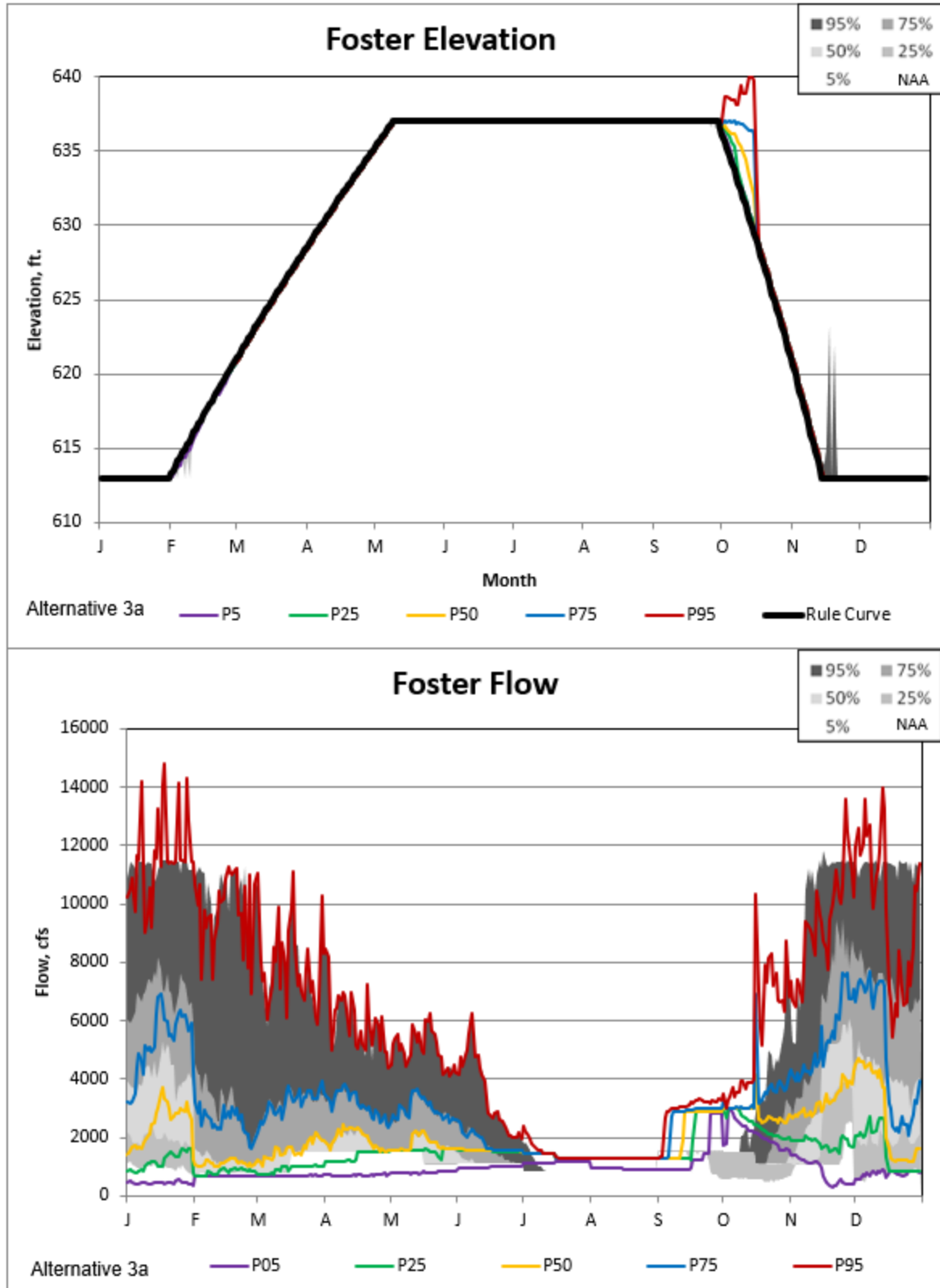

Figure 5-80. Foster Alternative 3A Non-exceedance Plot.

Willamette Valley System Operations and Maintenance
Environmental Impact Statement

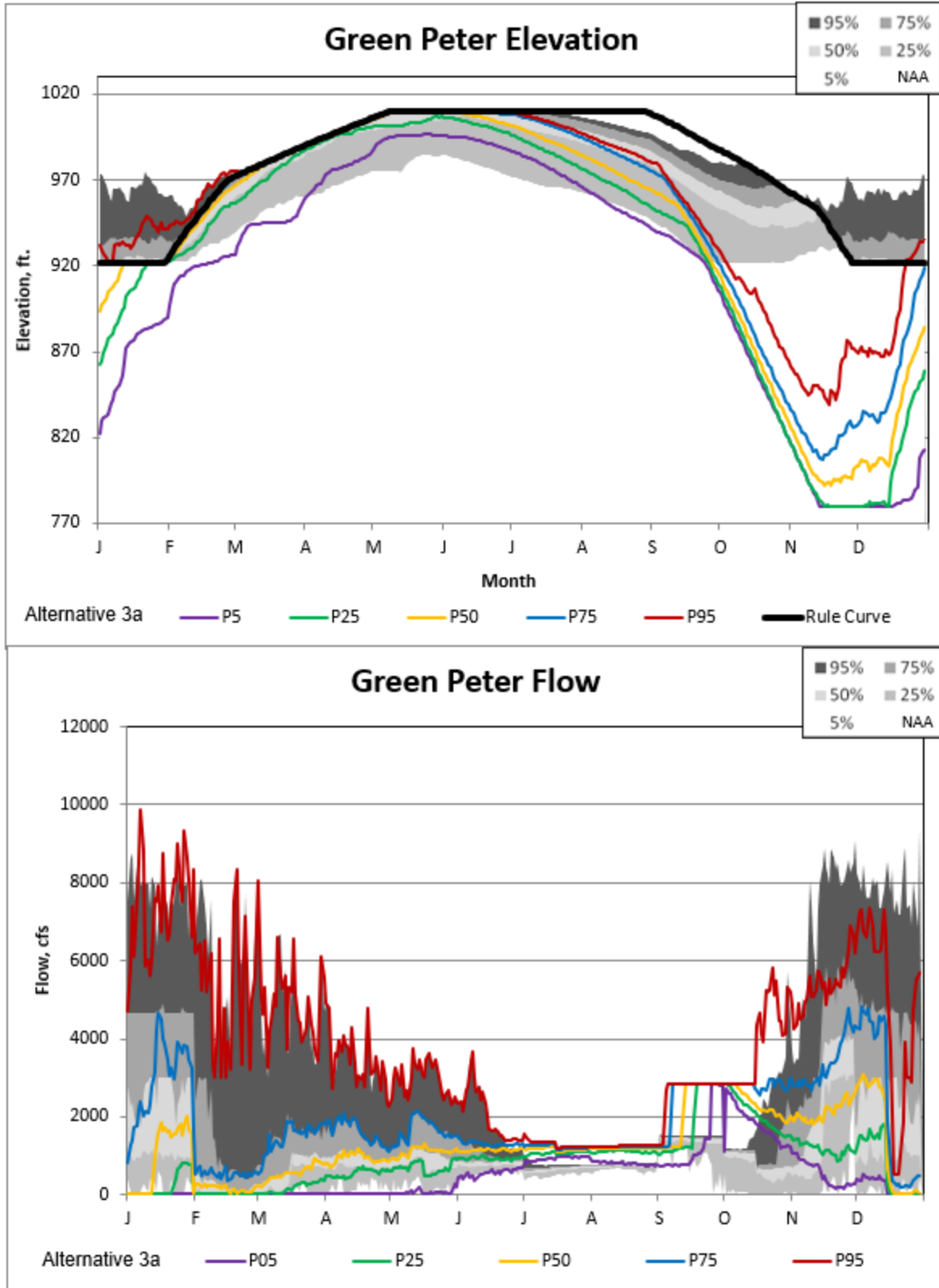

Figure 5-81. Green Peter Alternative 3A Non-exceedance Plot.

Willamette Valley System Operations and Maintenance
Environmental Impact Statement

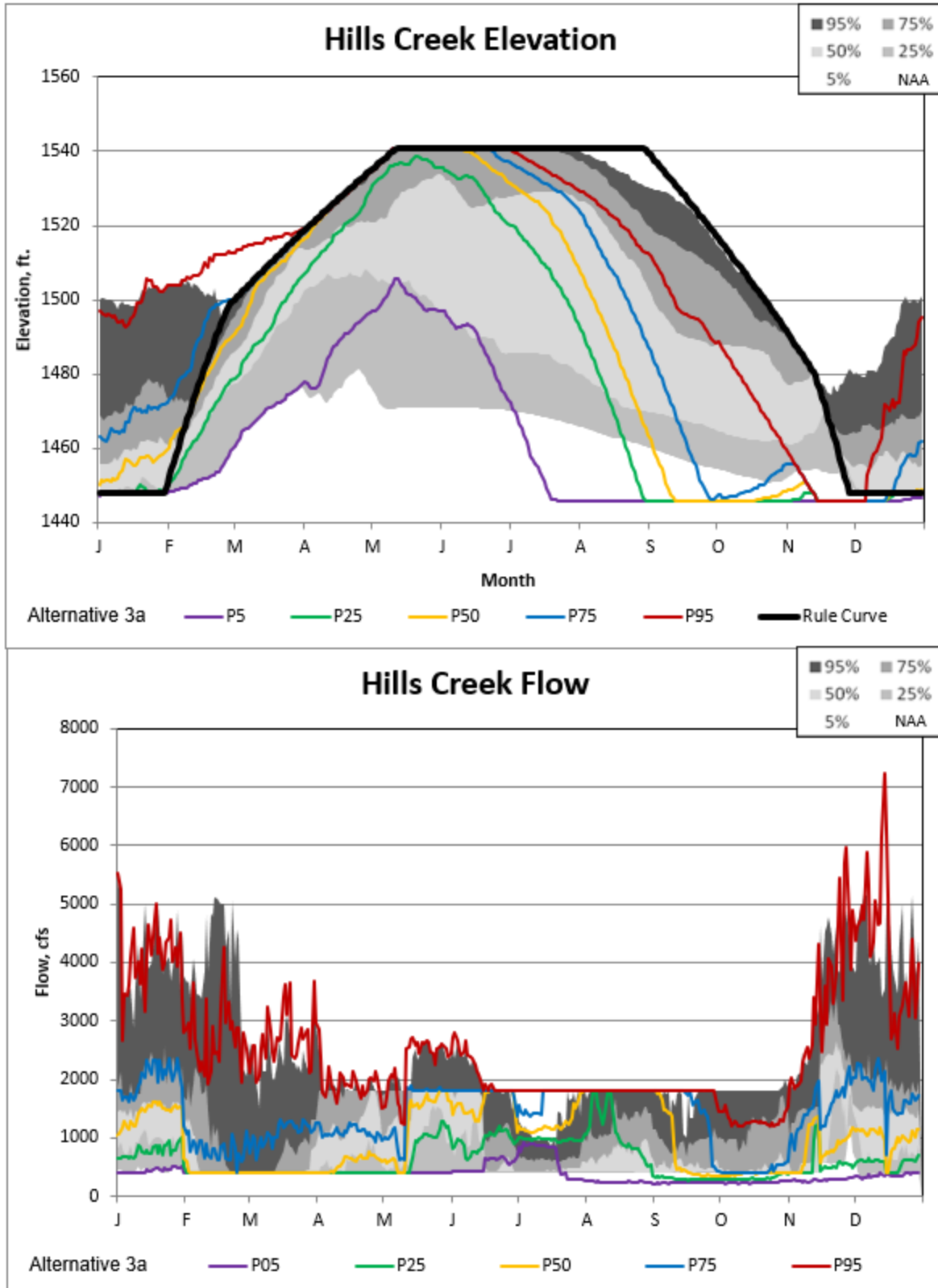

Figure 5-82. Hills Creek Alternative 3A Non-exceedance Plot.

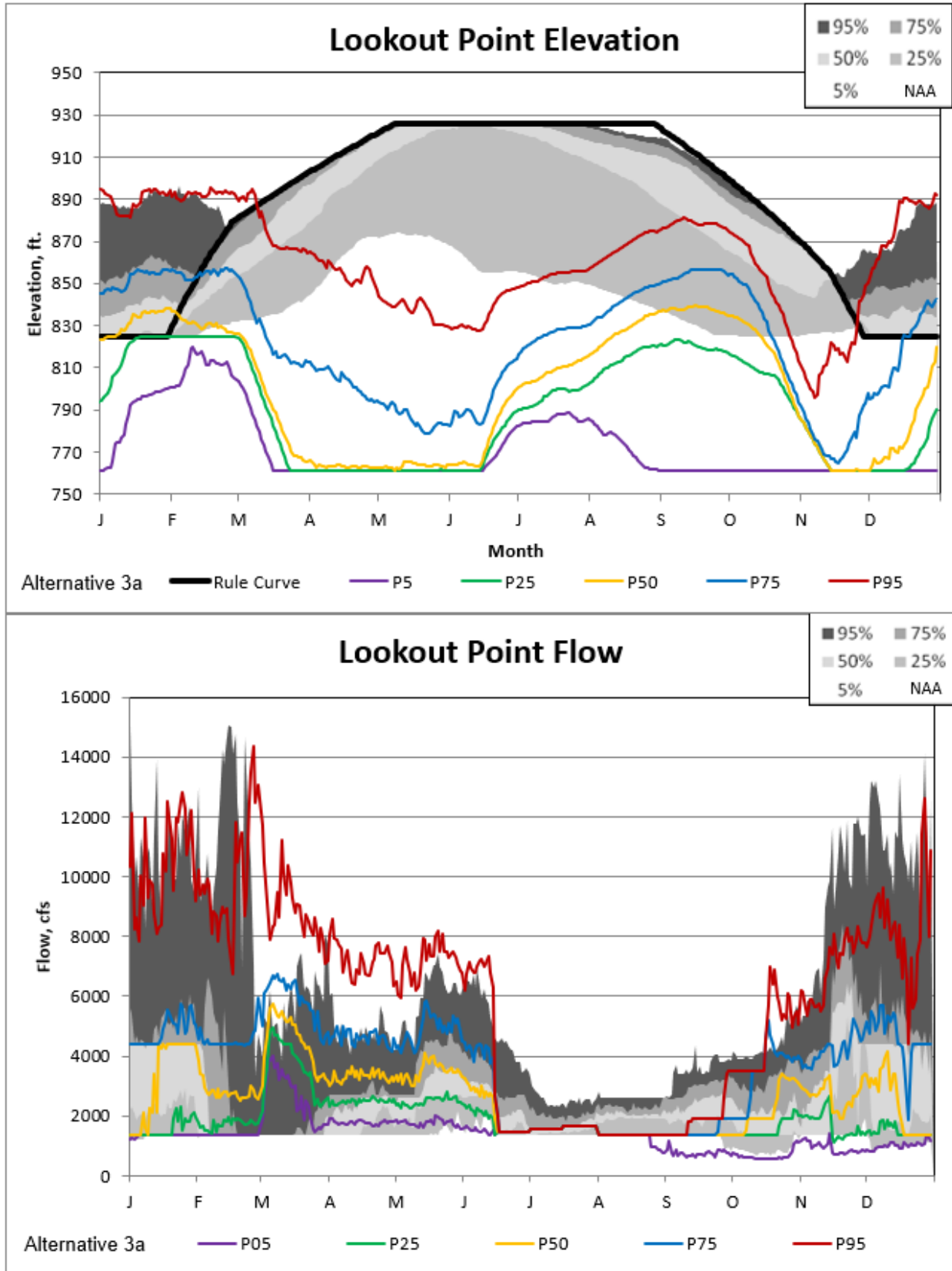

Figure 5-83. Lookout Point Alternative 3A Non-exceedance Plot.

Willamette Valley System Operations and Maintenance
Environmental Impact Statement

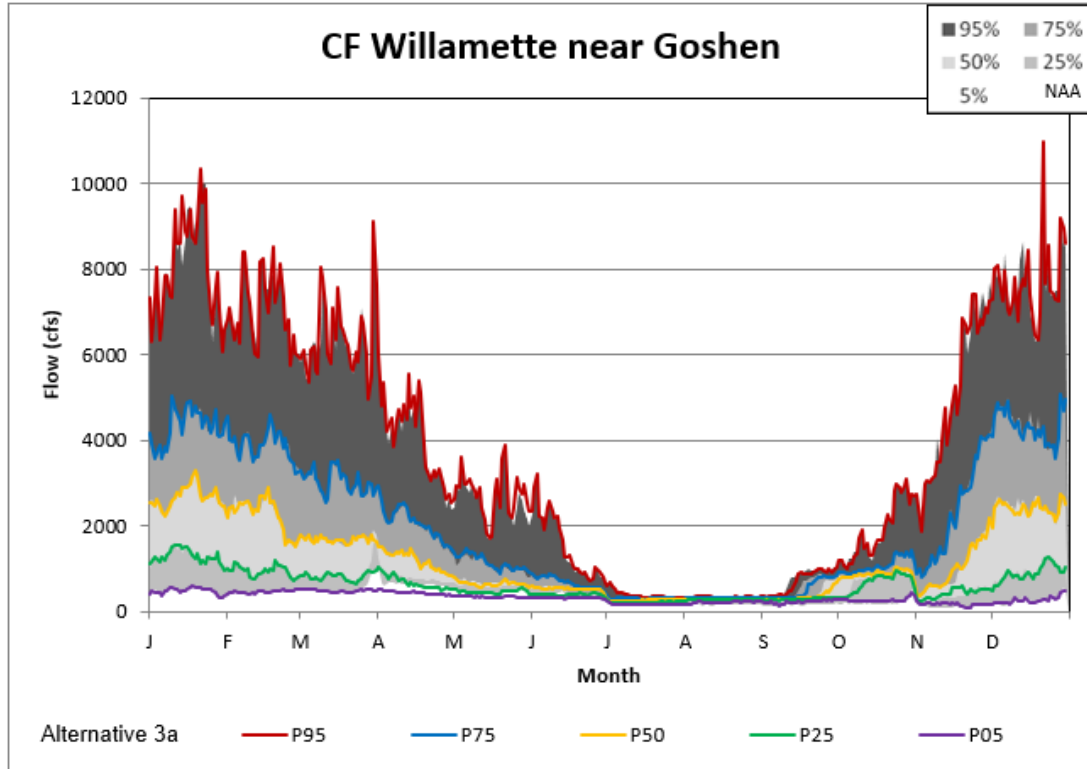

Figure 5-84. Goshen Alternative 3A Non-exceedance Plot.

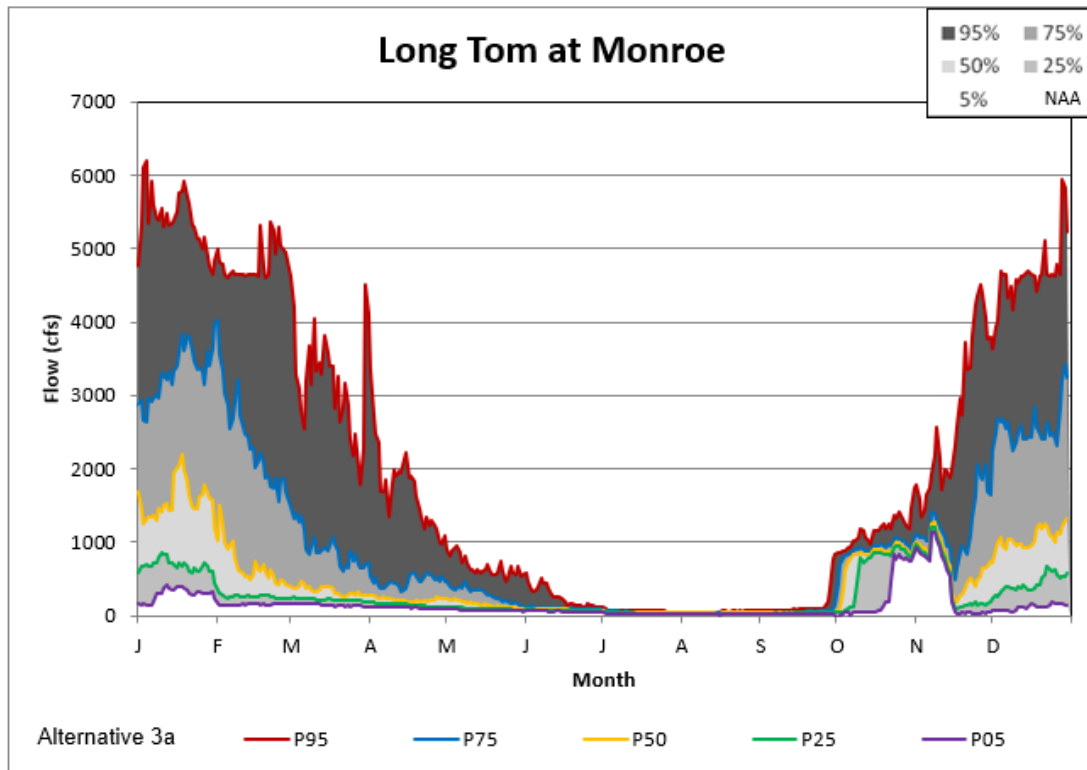

Figure 5-85. Monroe Alternative 3A Non-exceedance Plot.

Willamette Valley System Operations and Maintenance
Environmental Impact Statement

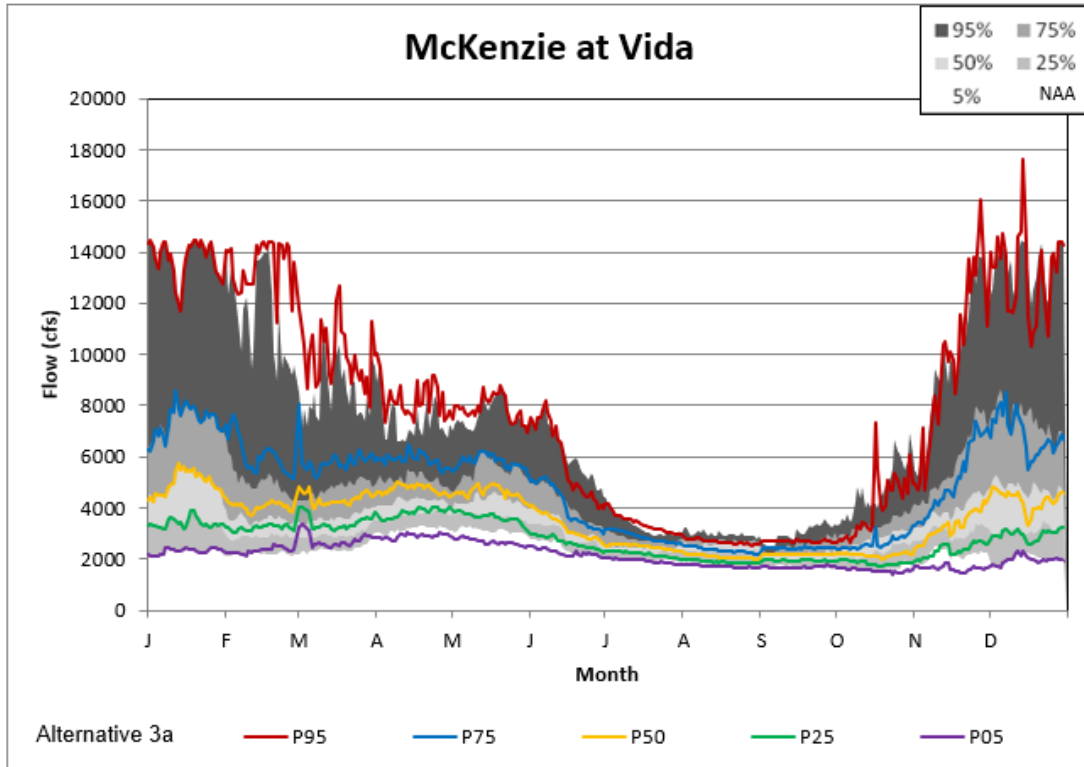

Figure 5-86. Vida Alternative 3A Non-exceedance Plot.

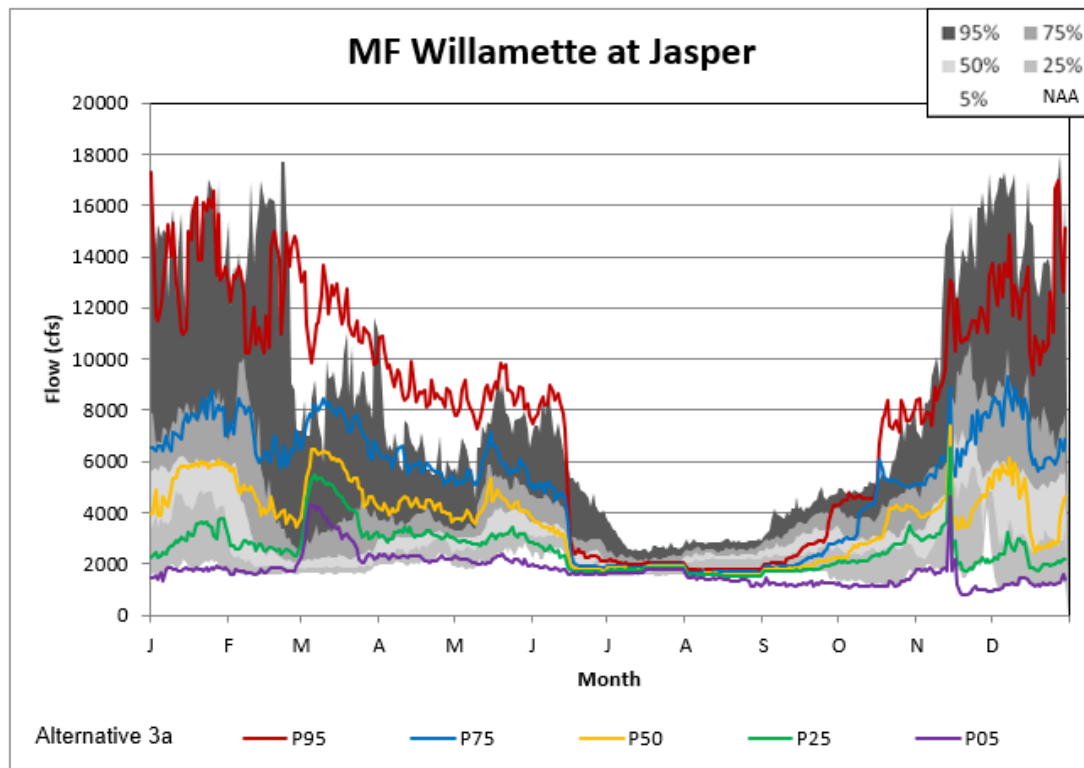

Figure 5-87. Jasper Alternative 3A Non-exceedance Plot.

Willamette Valley System Operations and Maintenance
Environmental Impact Statement

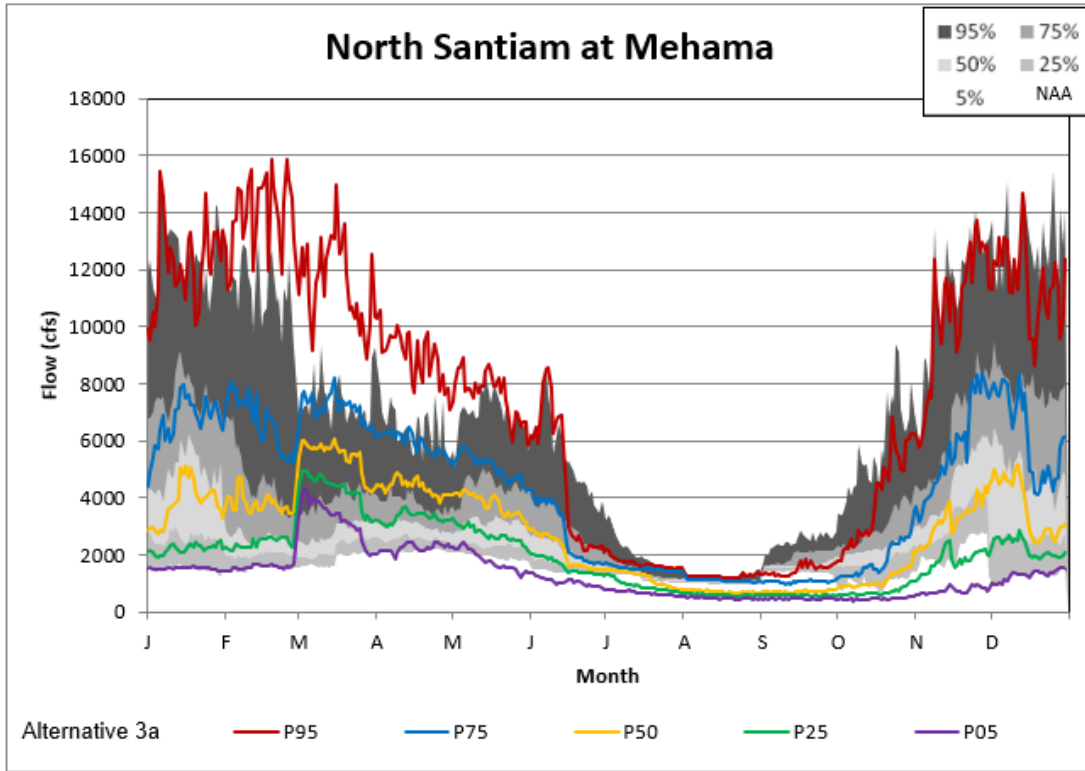

Figure 5-88. Mehama Alternative 3A Non-exceedance Plot.

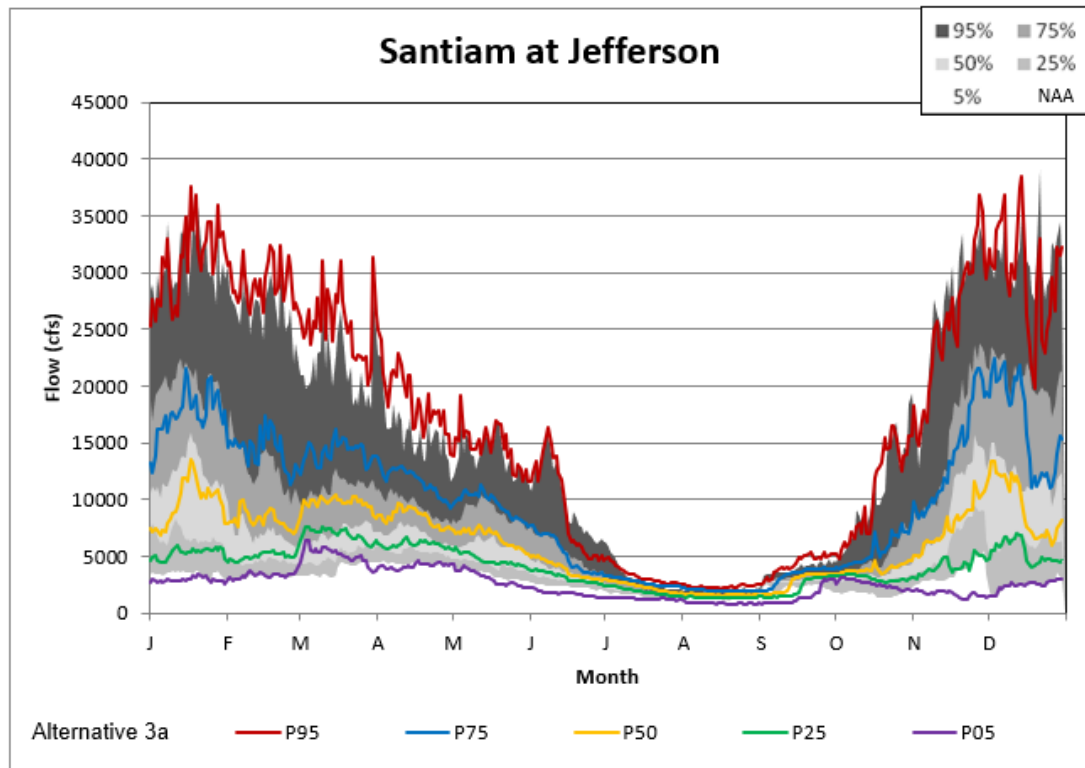

Figure 5-89. Jefferson Alternative 3A Non-exceedance Plot.

Willamette Valley System Operations and Maintenance
Environmental Impact Statement

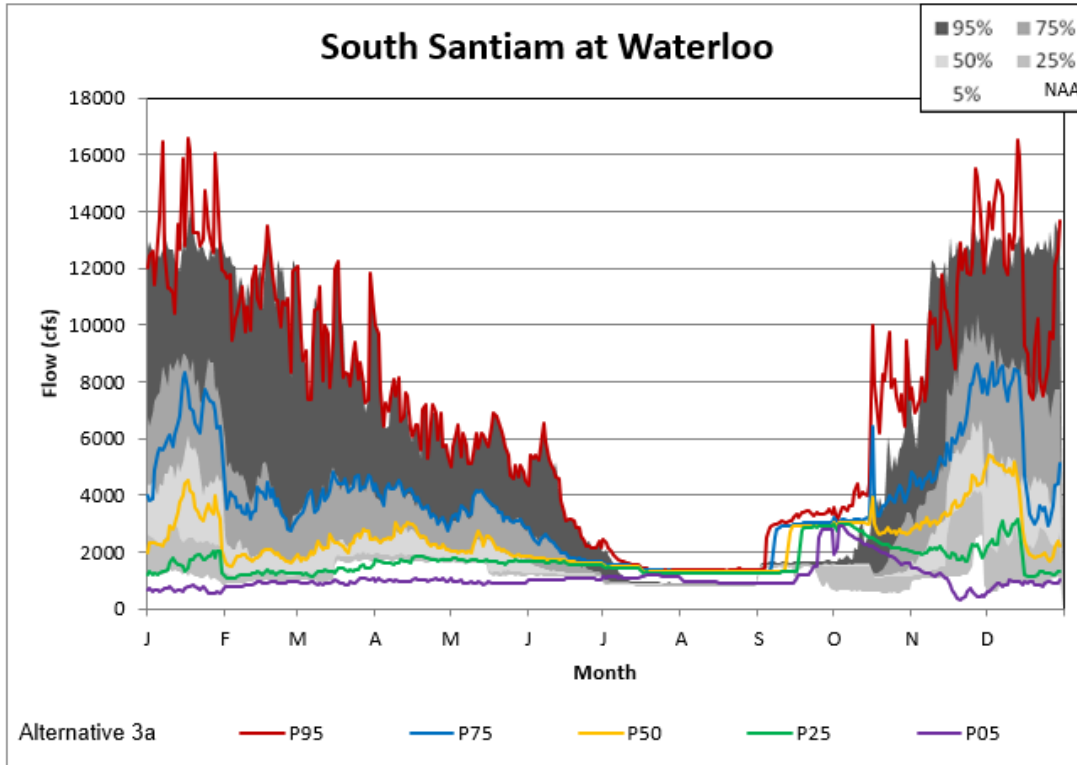

Figure 5-90. Waterloo Alternative 3A Non-exceedance Plot.

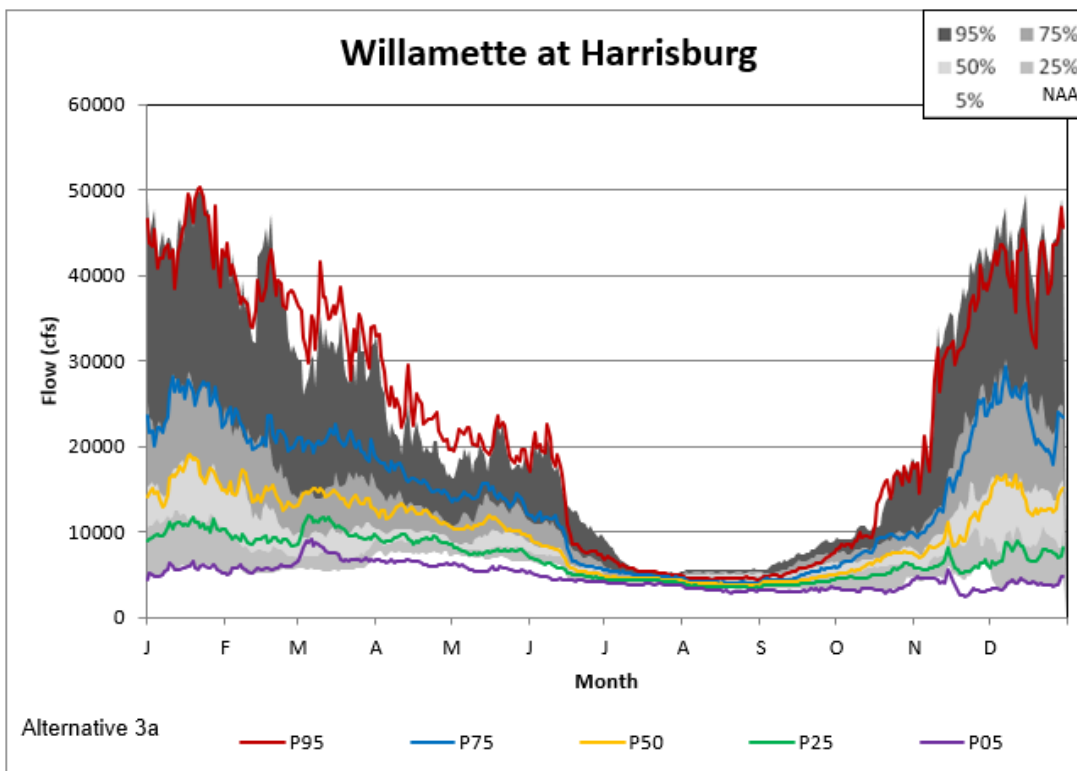

Figure 5-91. Harrisburg Alternative 3A Non-exceedance Plot.

Willamette Valley System Operations and Maintenance
Environmental Impact Statement

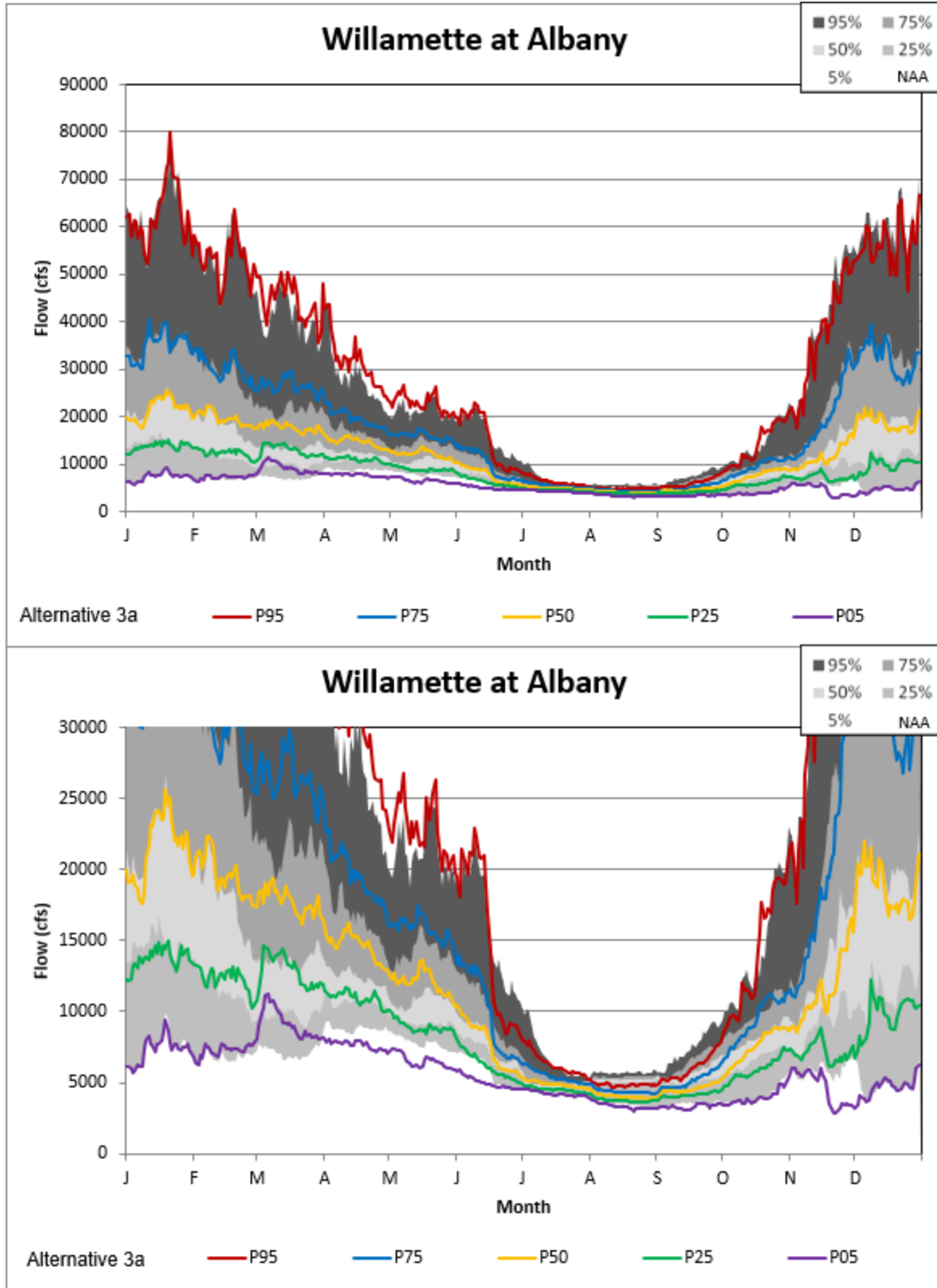

Figure 5-92. Albany Alternative 3A Non-exceedance Plot.

Willamette Valley System Operations and Maintenance
Environmental Impact Statement

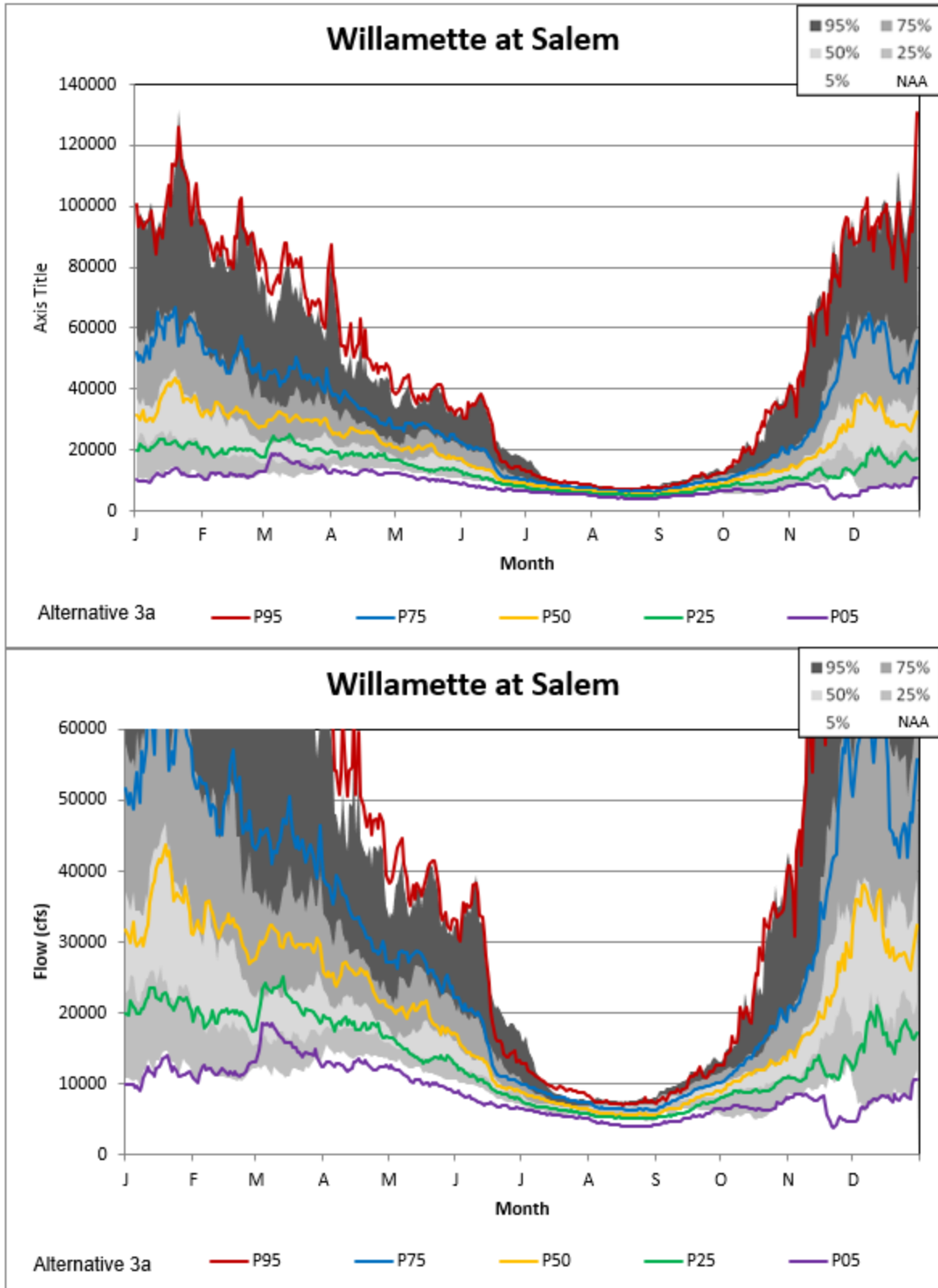

Figure 5-93. Salem Alternative 3A Non-exceedance Plot.

5.5 Alternative 3B

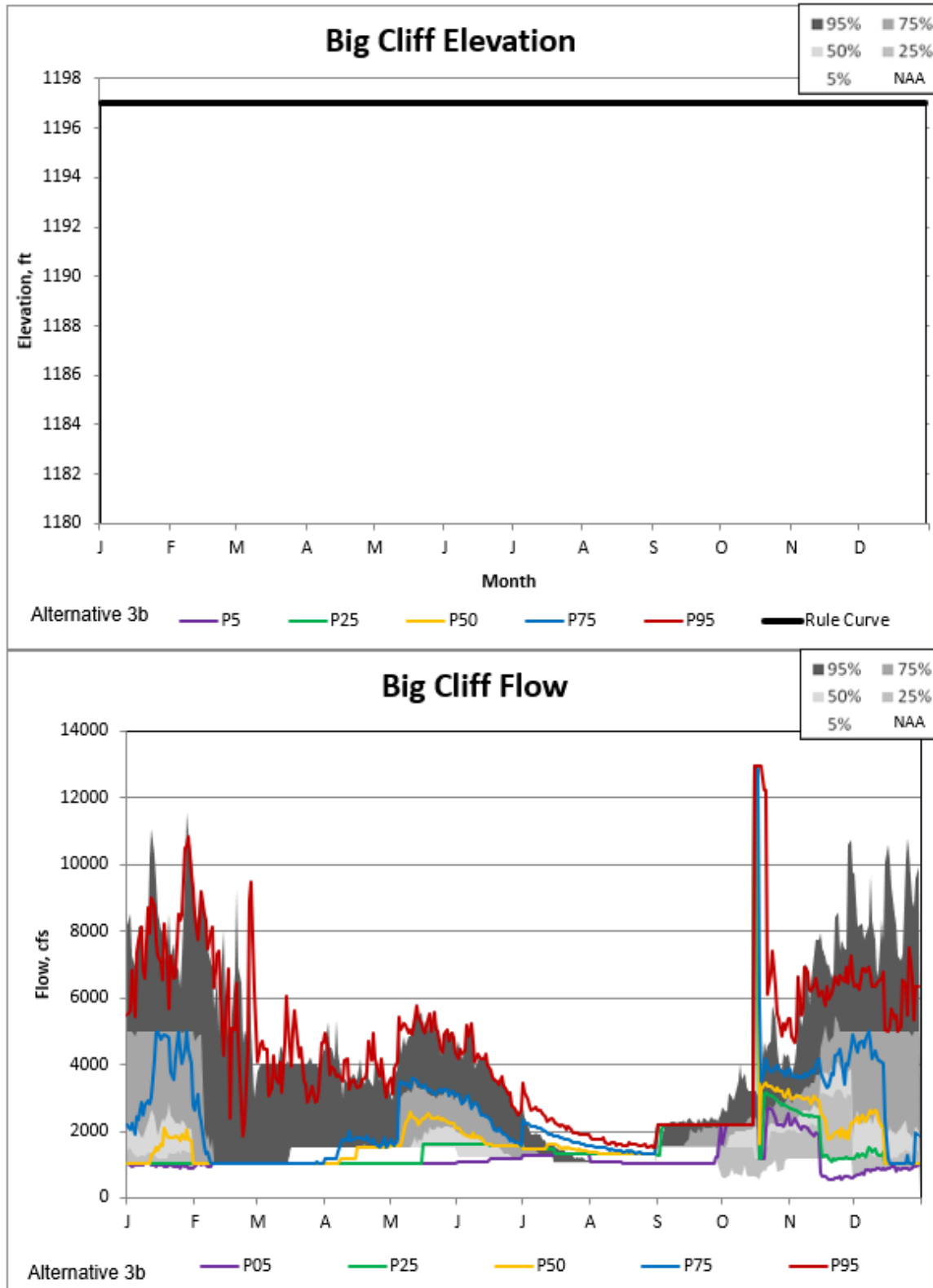

Figure 5-94. Big Cliff Alternative 3B Non-exceedance Plot.

Willamette Valley System Operations and Maintenance
Environmental Impact Statement

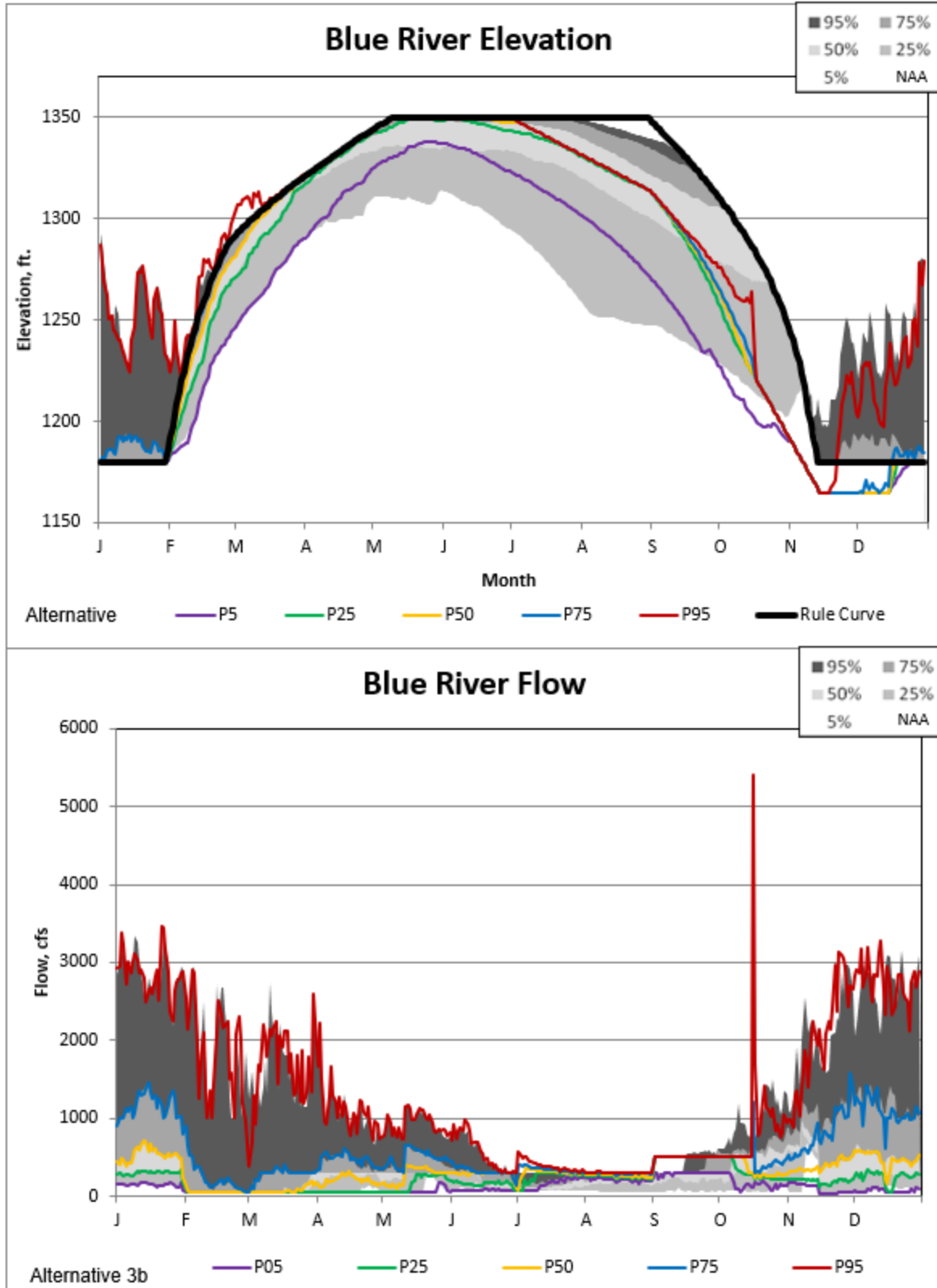

Figure 5-95. Blue River Alternative 3B Non-exceedance Plot.

Willamette Valley System Operations and Maintenance
Environmental Impact Statement

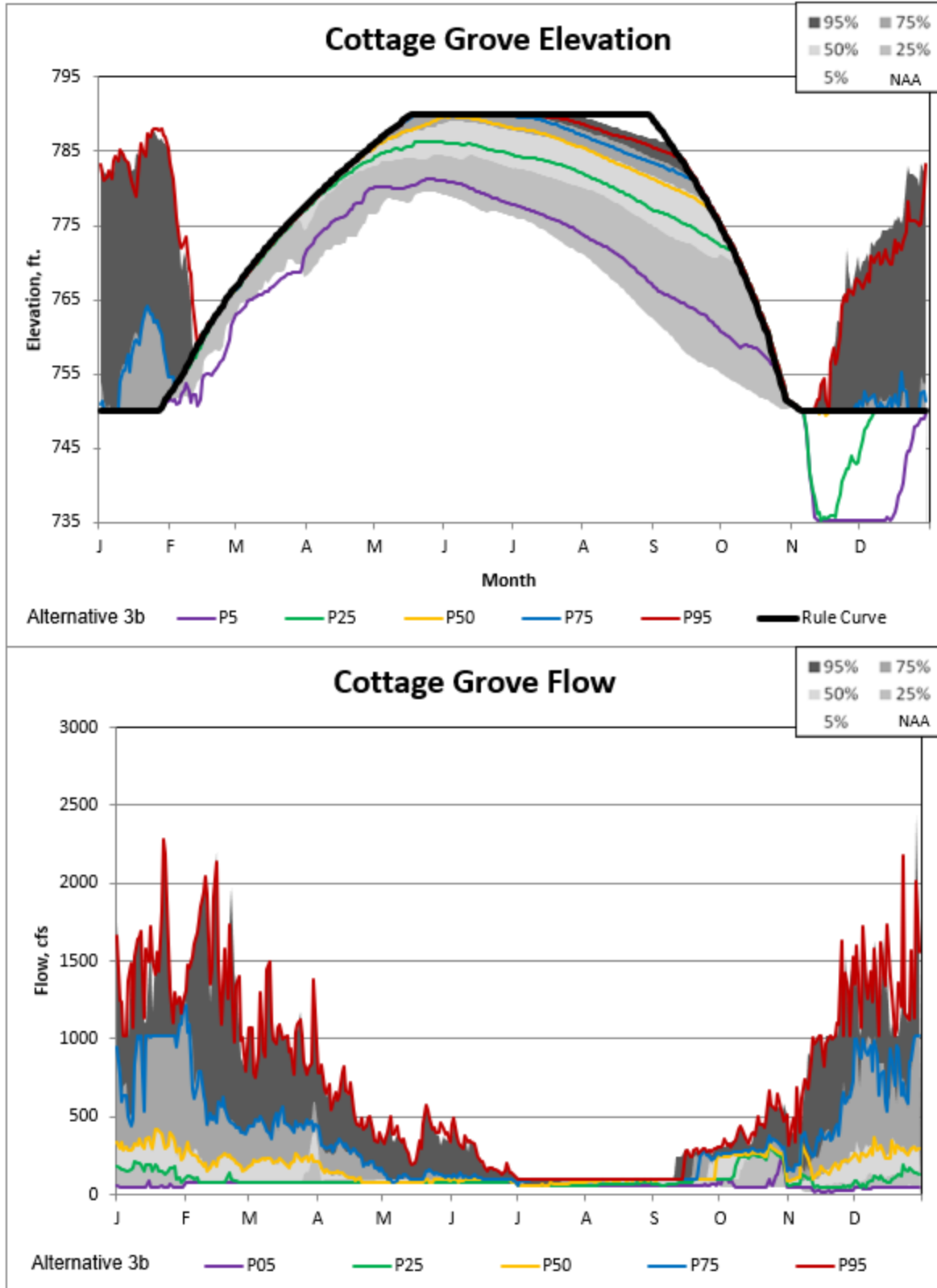

Figure 5-96. Cottage Grove Alternative 3B Non-exceedance Plot.

Willamette Valley System Operations and Maintenance
Environmental Impact Statement

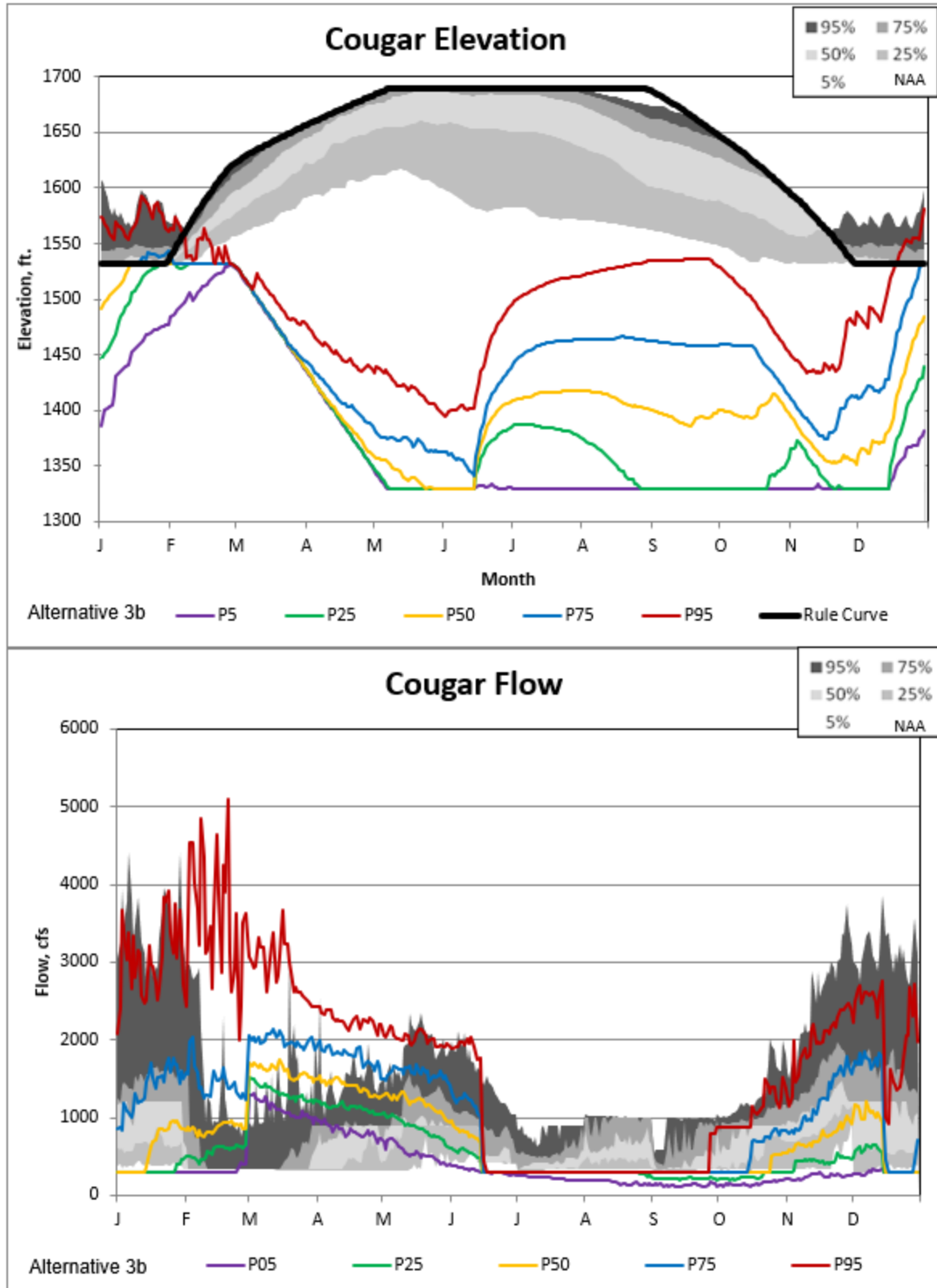

Figure 5-97. Cougar Alternative 3B Non-exceedance Plot.

Willamette Valley System Operations and Maintenance
Environmental Impact Statement

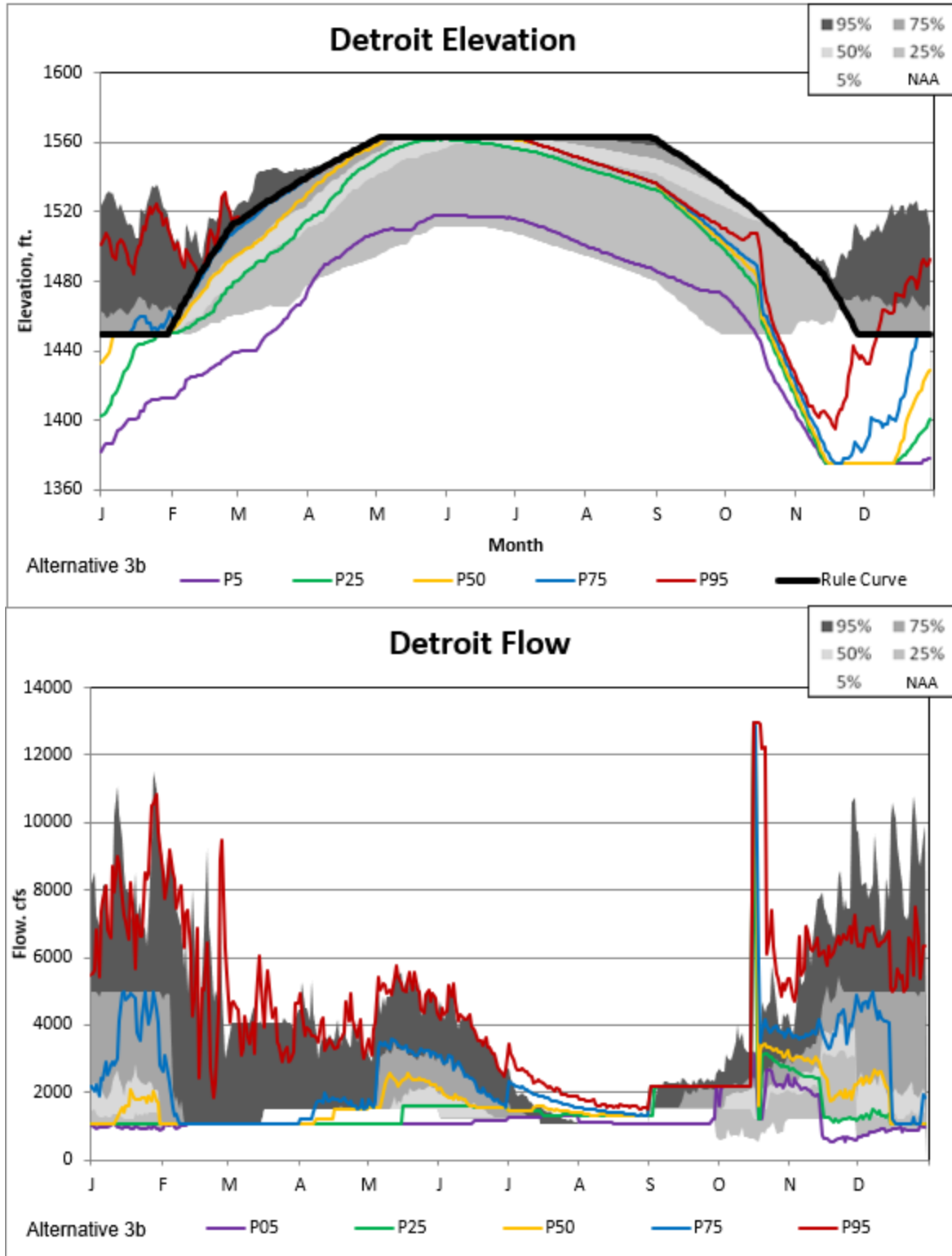

Figure 5-98. Detroit Alternative 3B Non-exceedance Plot.

Willamette Valley System Operations and Maintenance
Environmental Impact Statement

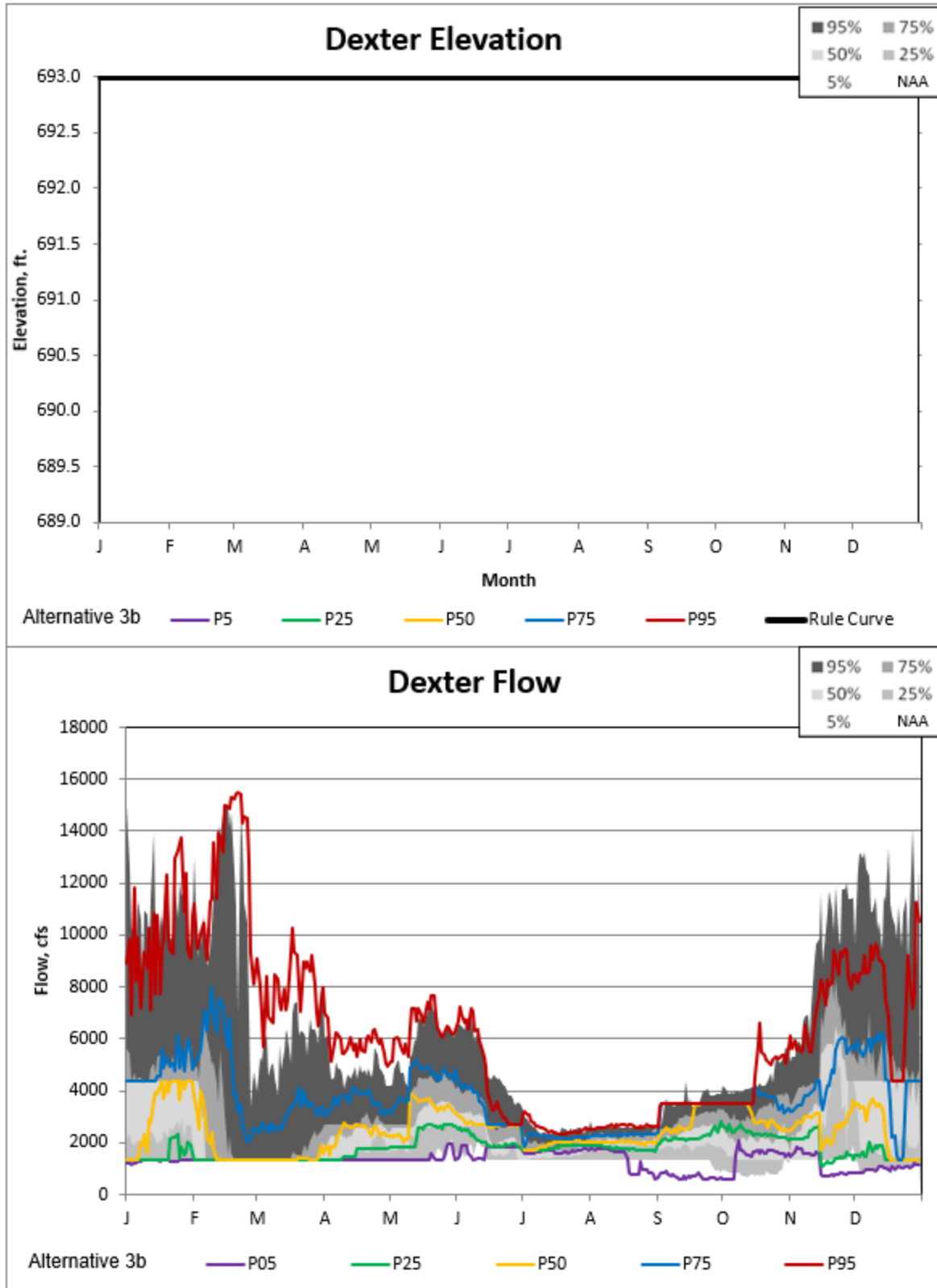

Figure 5-99. Dexter Alternative 3B Non-exceedance Plot.

Willamette Valley System Operations and Maintenance
Environmental Impact Statement

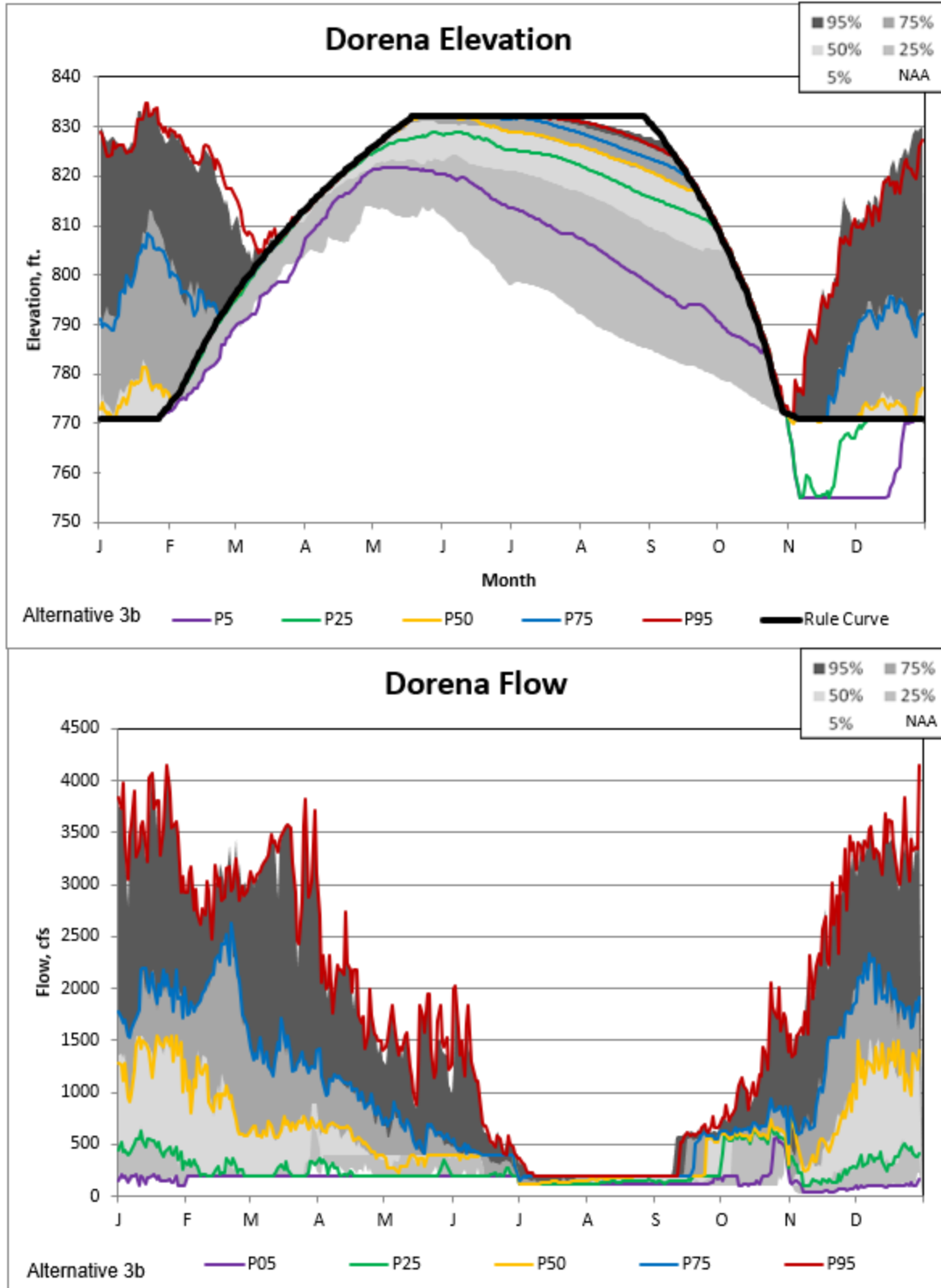

Figure 5-100. Dorena Alternative 3B Non-exceedance Plot.

Willamette Valley System Operations and Maintenance
Environmental Impact Statement

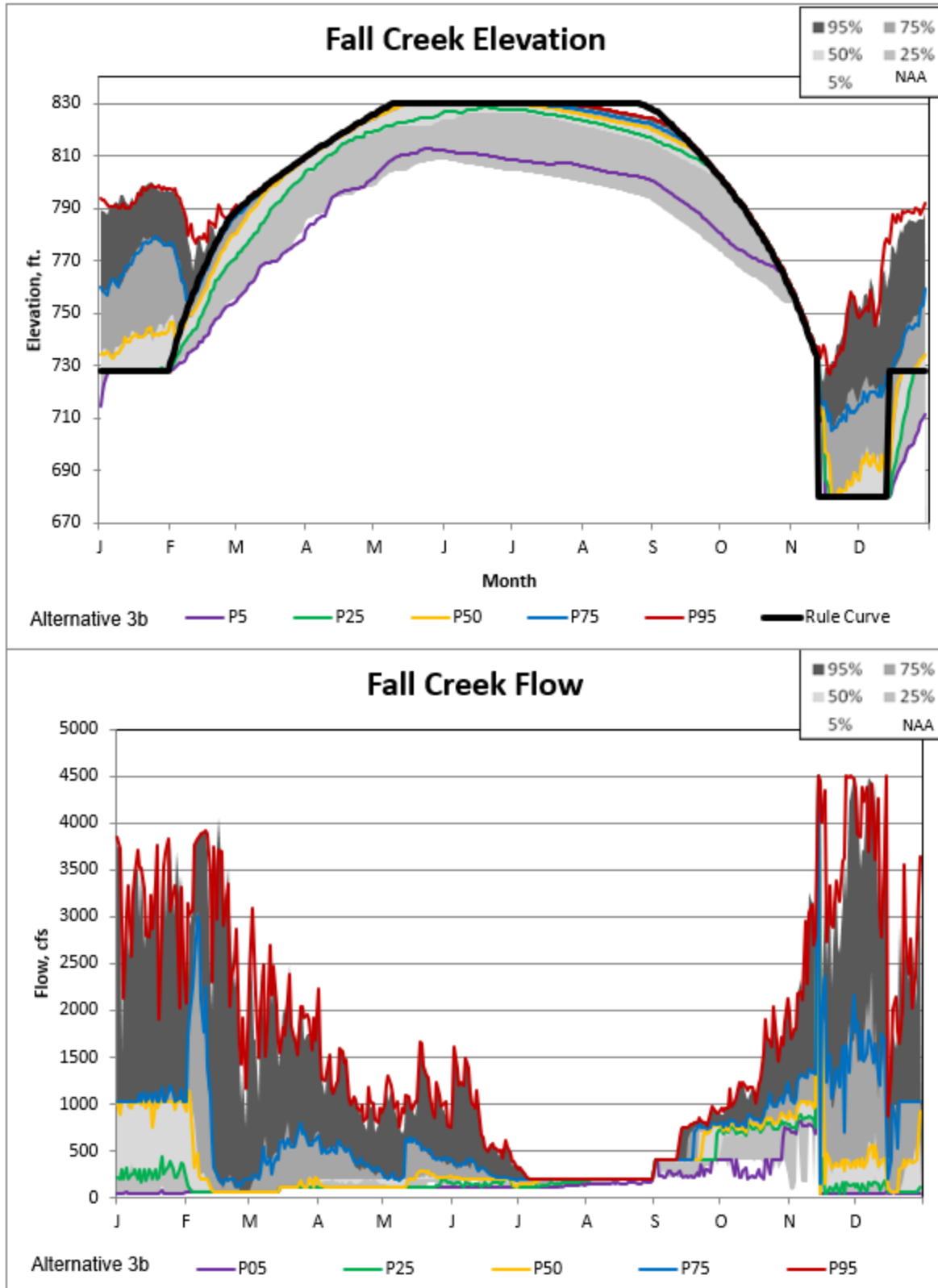

Figure 5-101. Fall Creek Alternative 3B Non-exceedance Plot.

Willamette Valley System Operations and Maintenance
Environmental Impact Statement

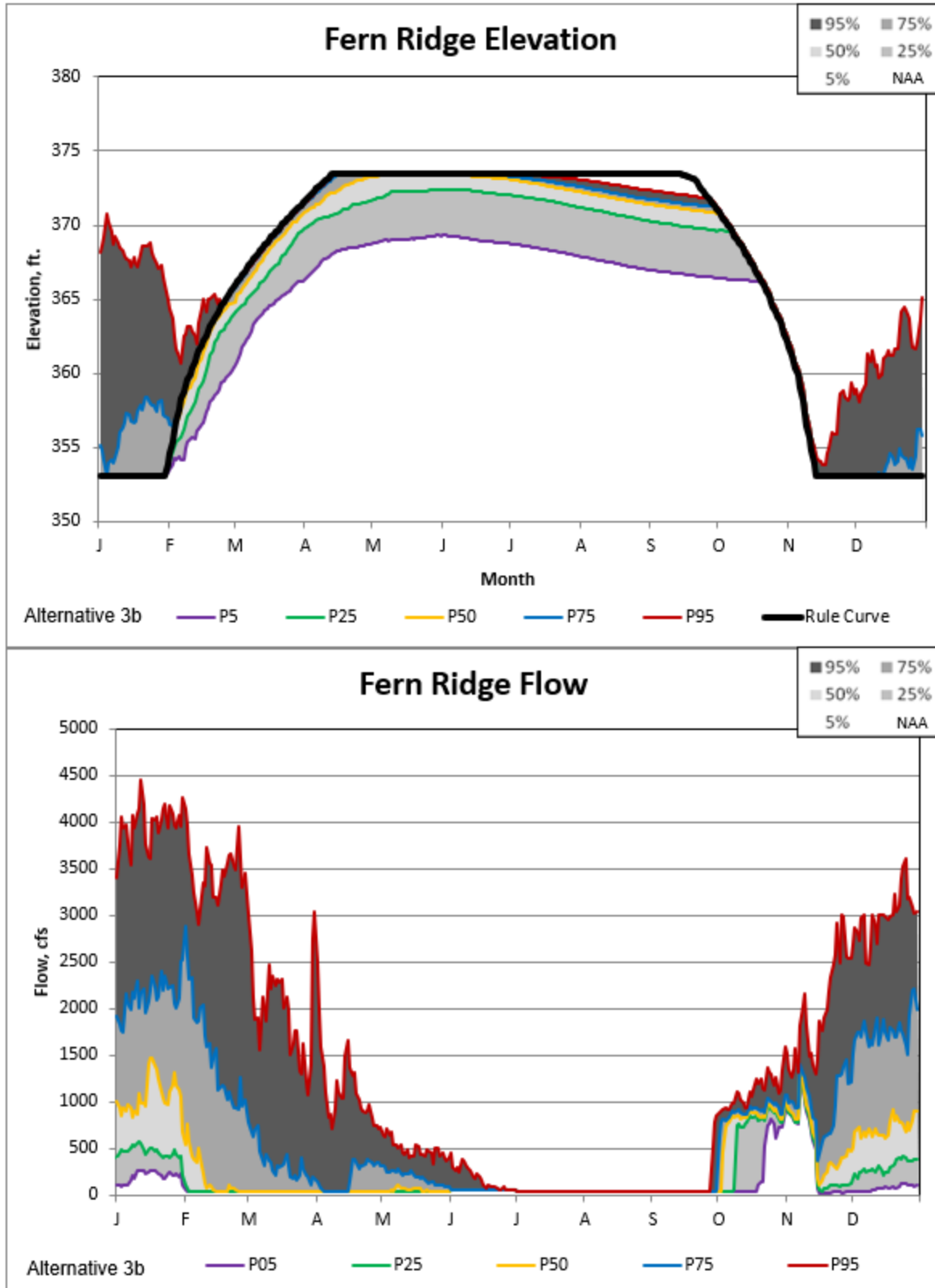

Figure 5-102. Fern Ridge Alternative 3B Non-exceedance Plot.

Willamette Valley System Operations and Maintenance
Environmental Impact Statement

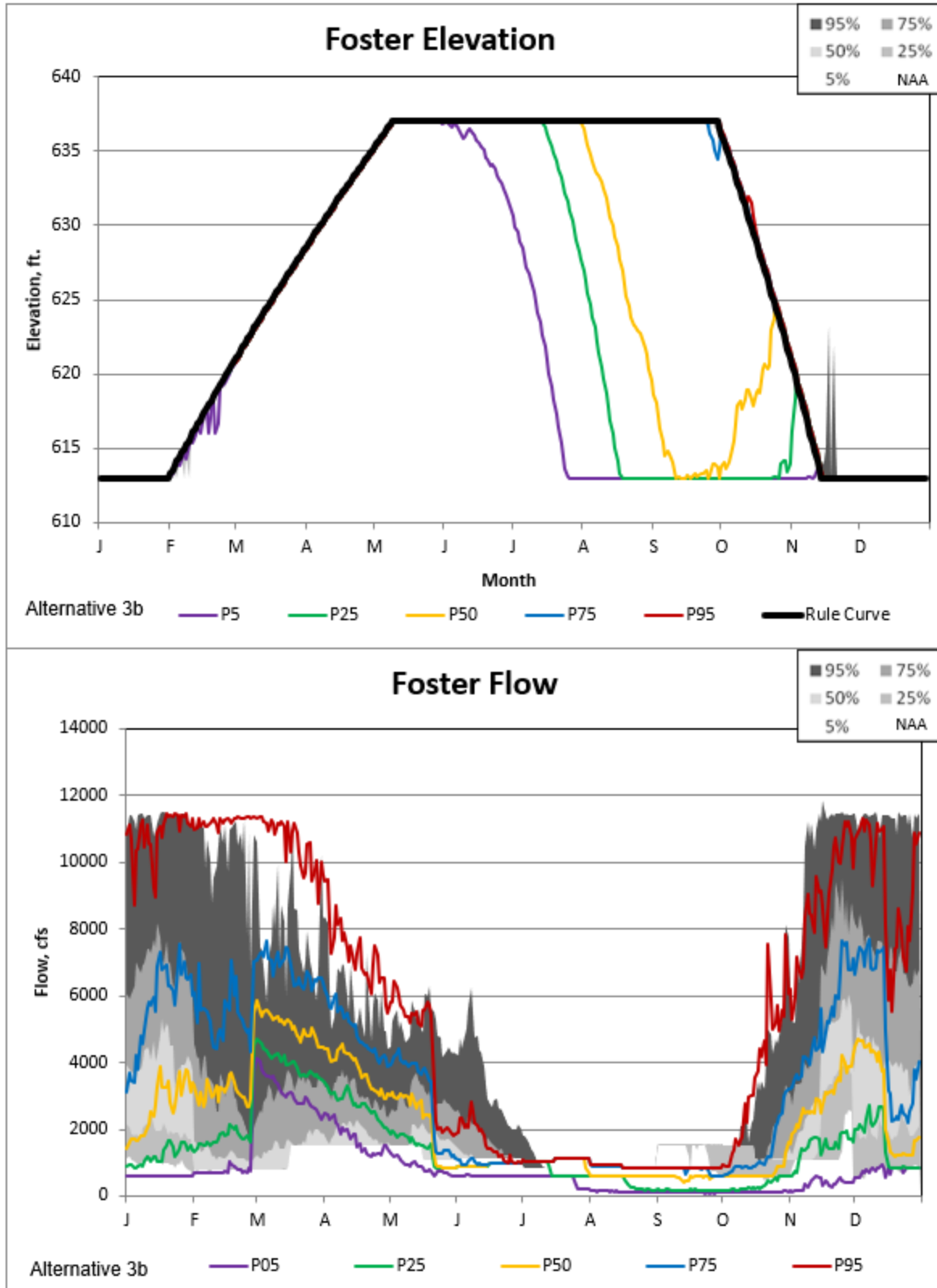

Figure 5-103. Foster Alternative 3B Non-exceedance Plot.

Willamette Valley System Operations and Maintenance
Environmental Impact Statement

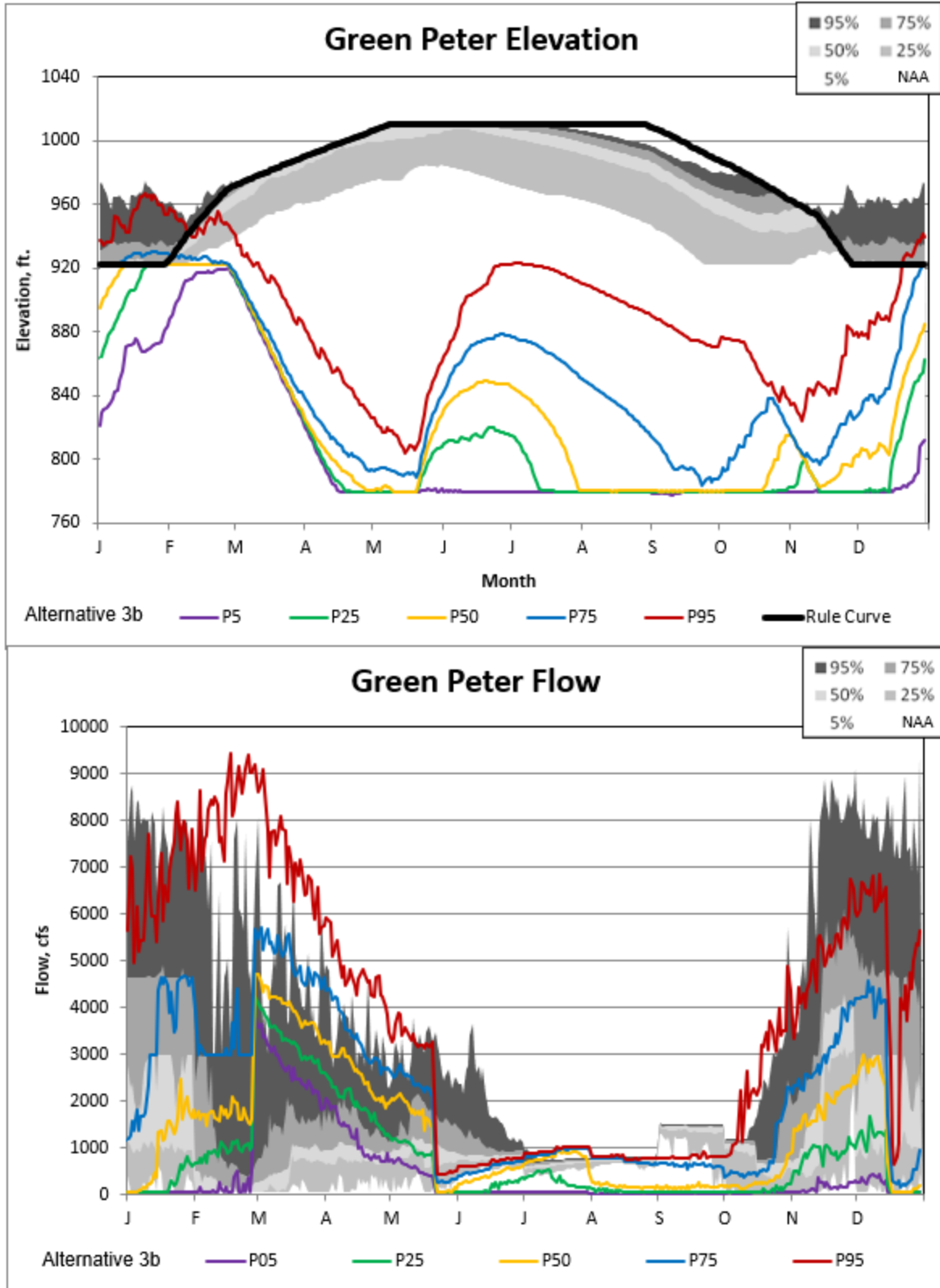

Figure 5-104. Green Peter Alternative 3B Non-exceedance Plot.

Willamette Valley System Operations and Maintenance
Environmental Impact Statement

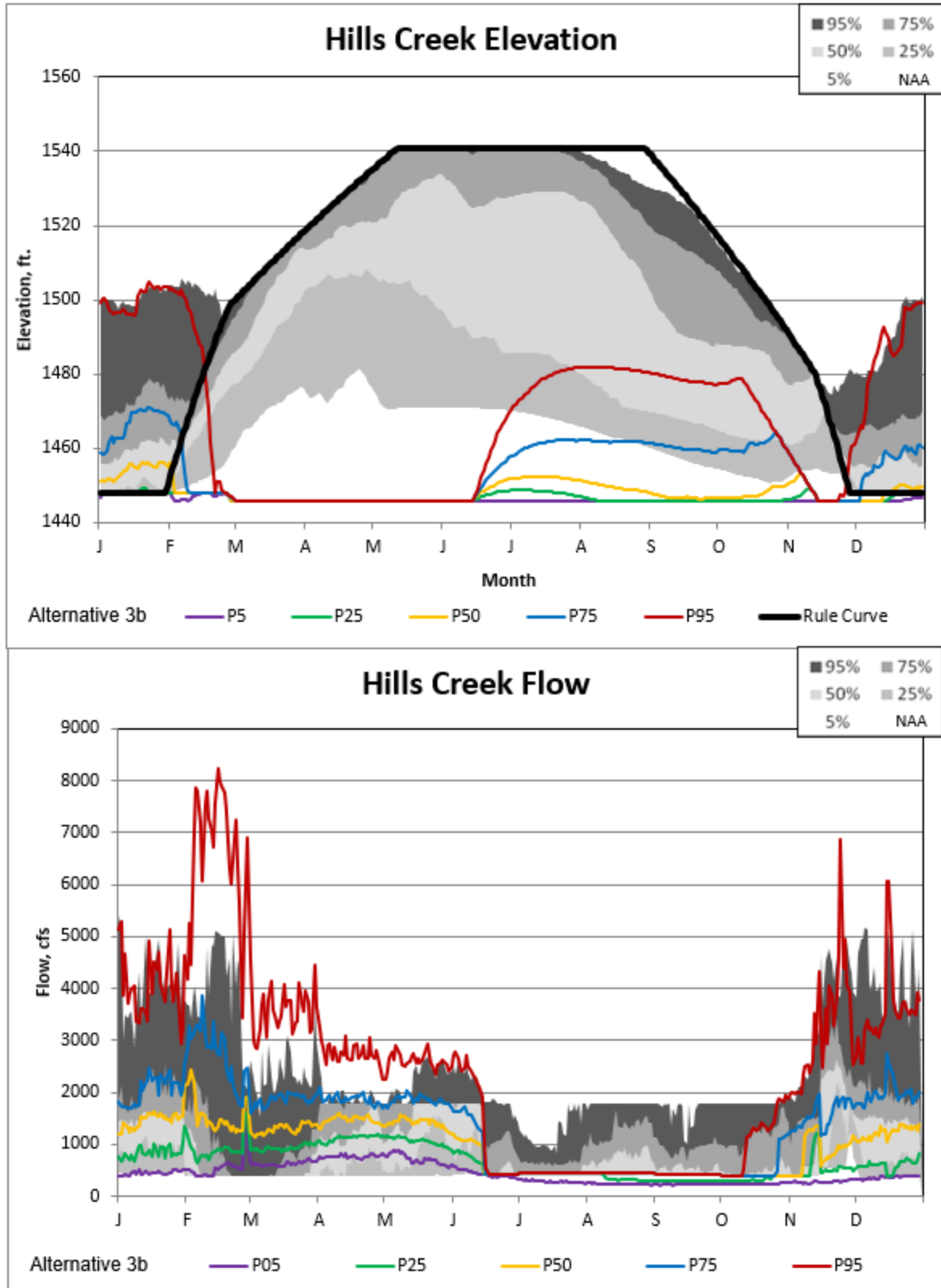

Figure 5-105. Hills Creek Alternative 3B Non-exceedance Plot.

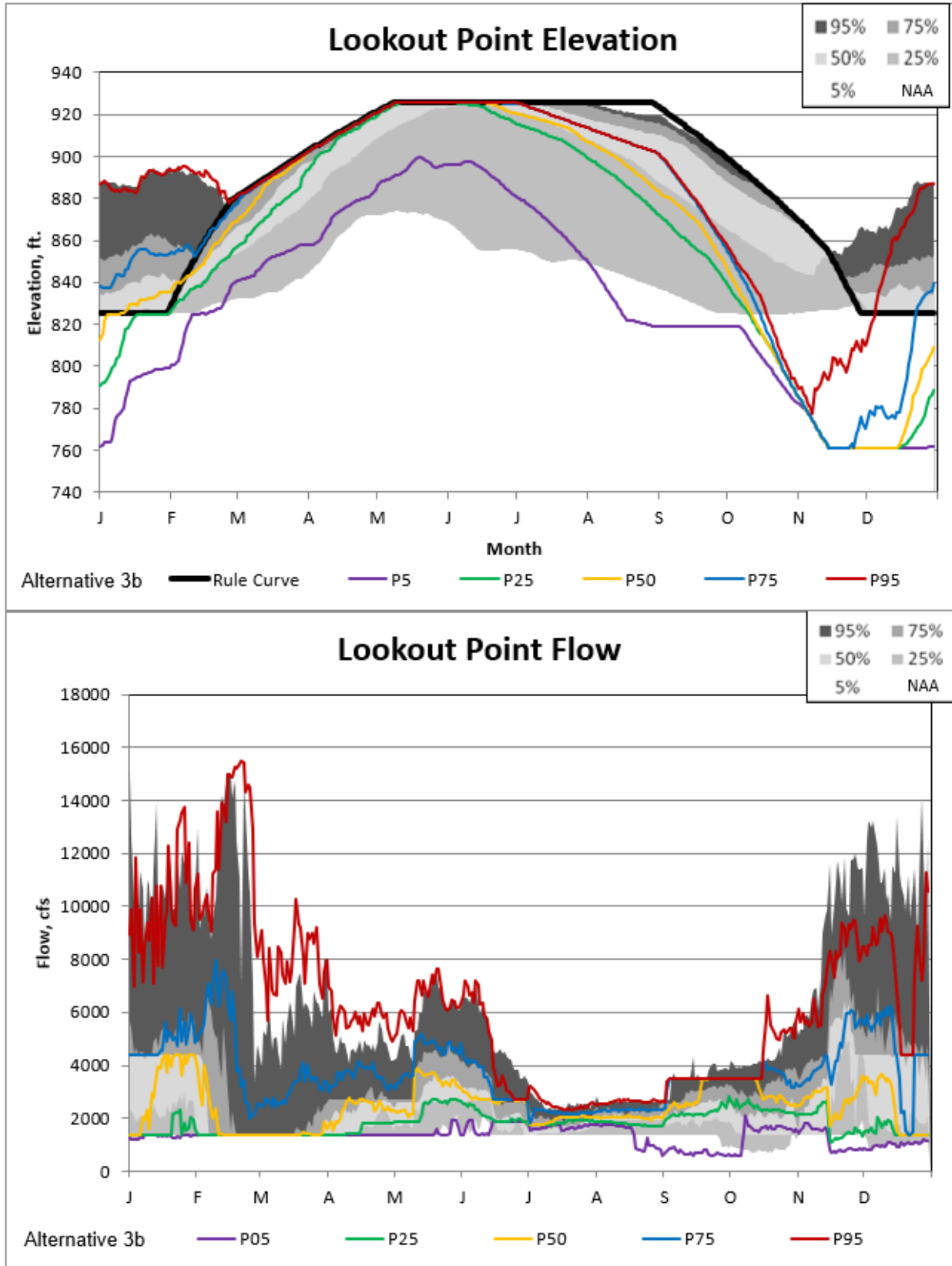

Figure 5-106. Lookout Point Alternative 3B Non-exceedance Plot.

Willamette Valley System Operations and Maintenance
Environmental Impact Statement

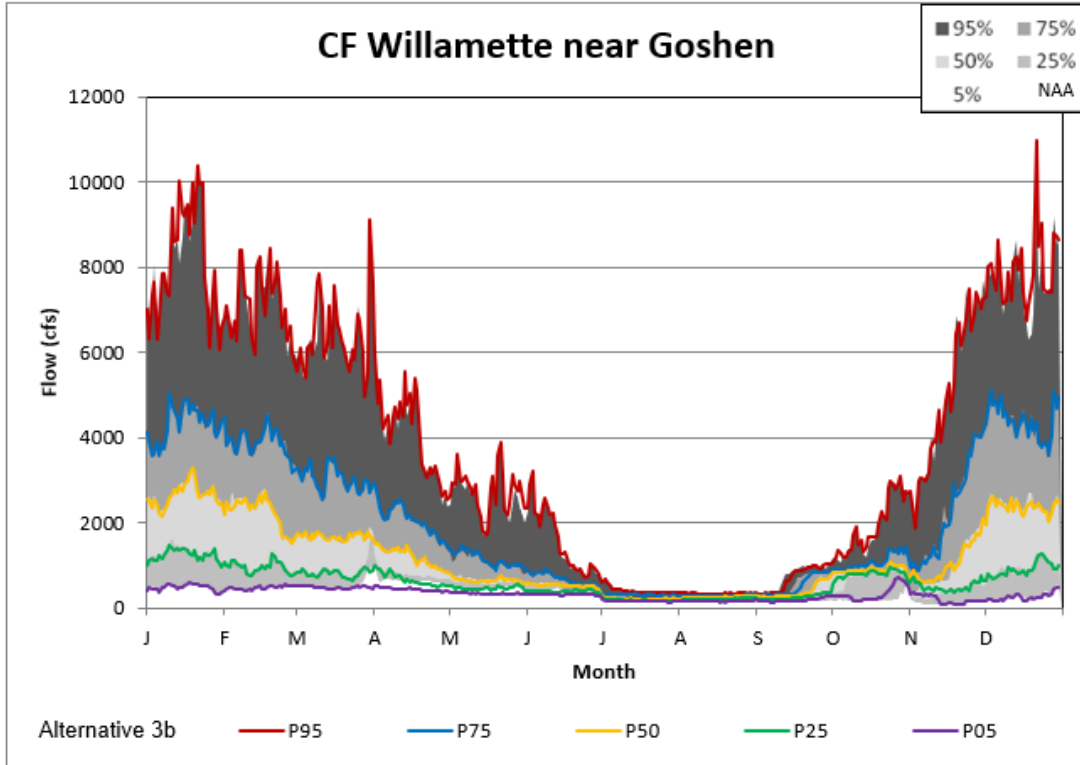

Figure 5-107. Goshen Alternative 3B Non-exceedance Plot.

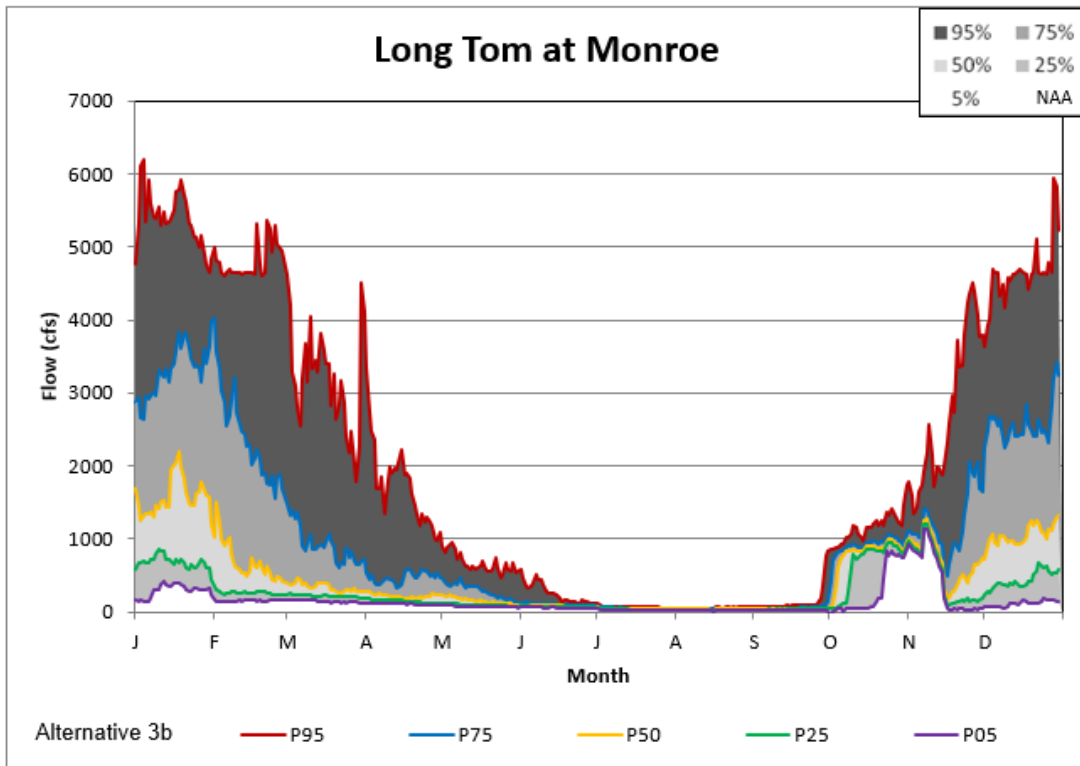

Figure 5-108. Monroe Alternative 3B Non-exceedance Plot.

*Willamette Valley System Operations and Maintenance
Environmental Impact Statement*

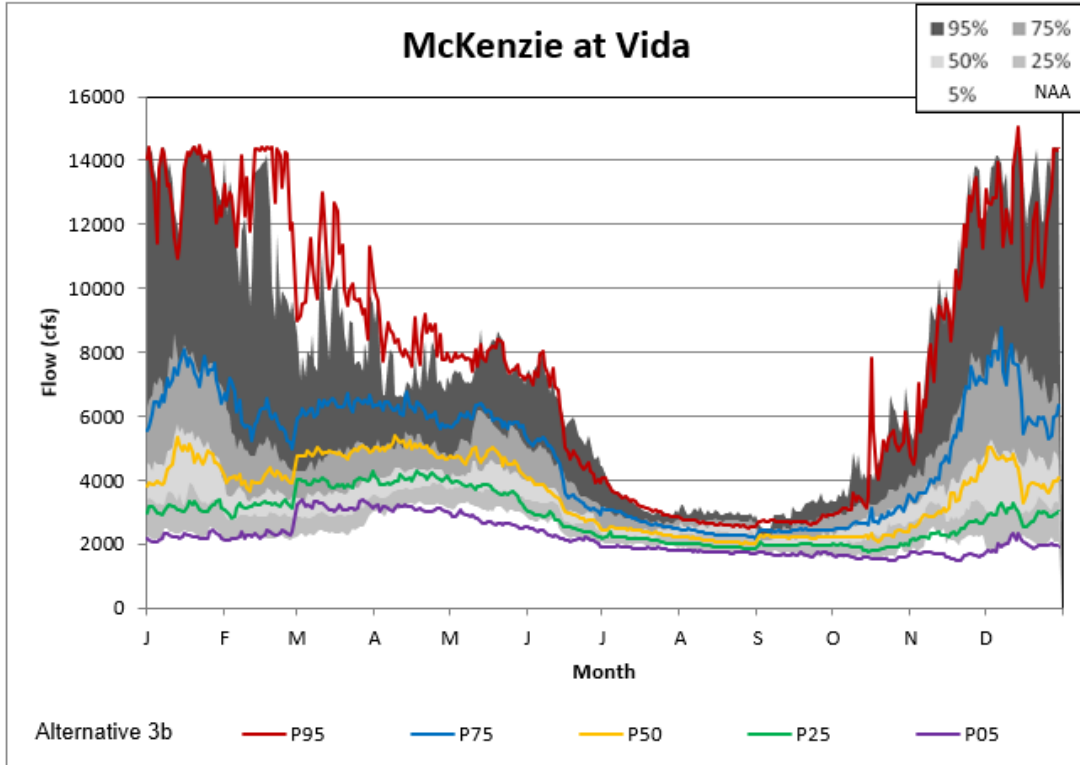

Figure 5-109. Vida Alternative 3B Non-exceedance Plot.

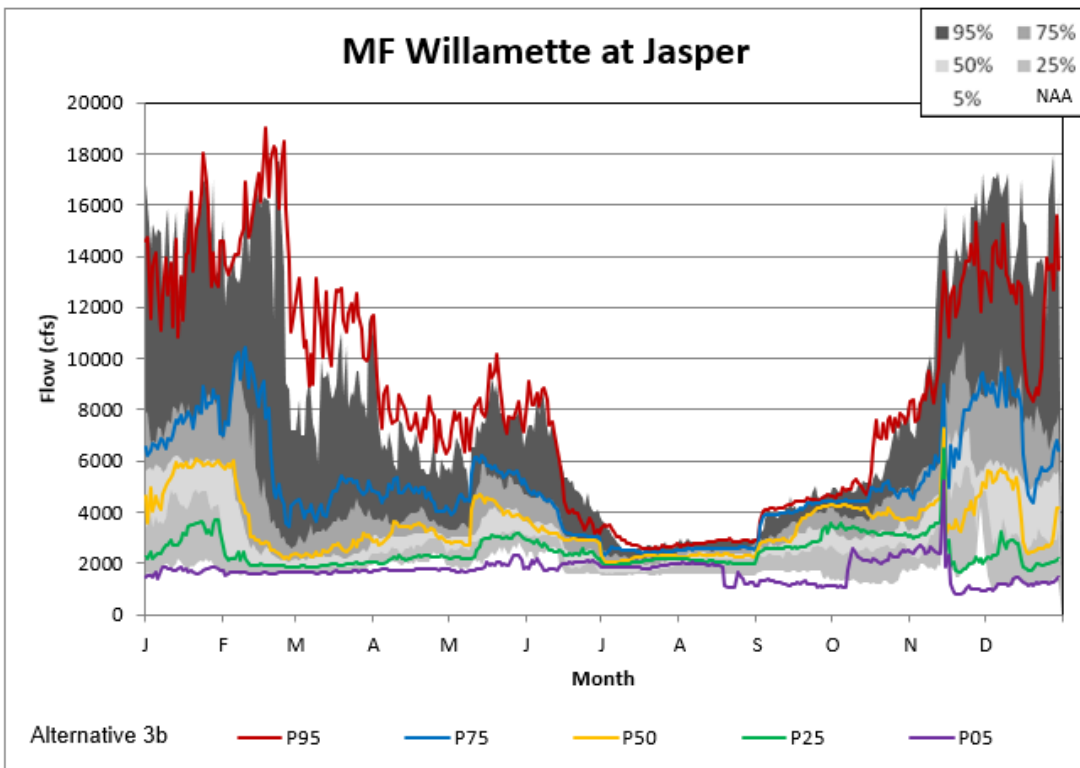

Figure 5-110. Jasper Alternative 3B Non-exceedance Plot.

Willamette Valley System Operations and Maintenance
Environmental Impact Statement

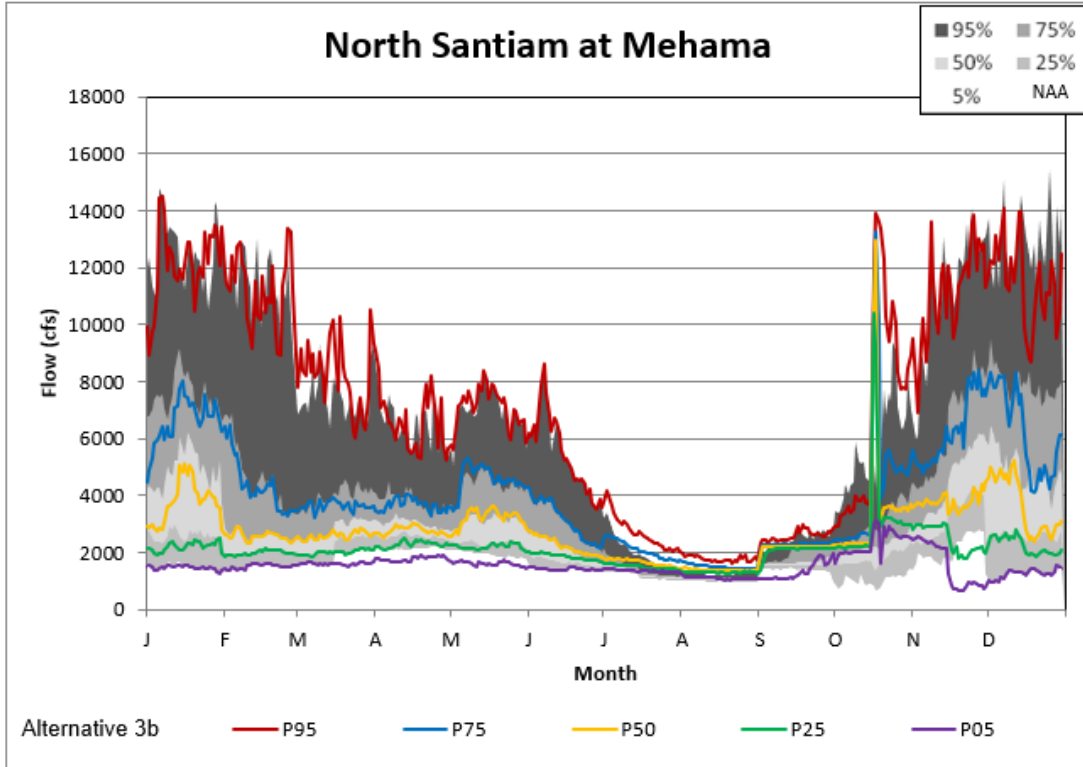

Figure 5-111. Mehama Alternative 3B Non-exceedance Plot.

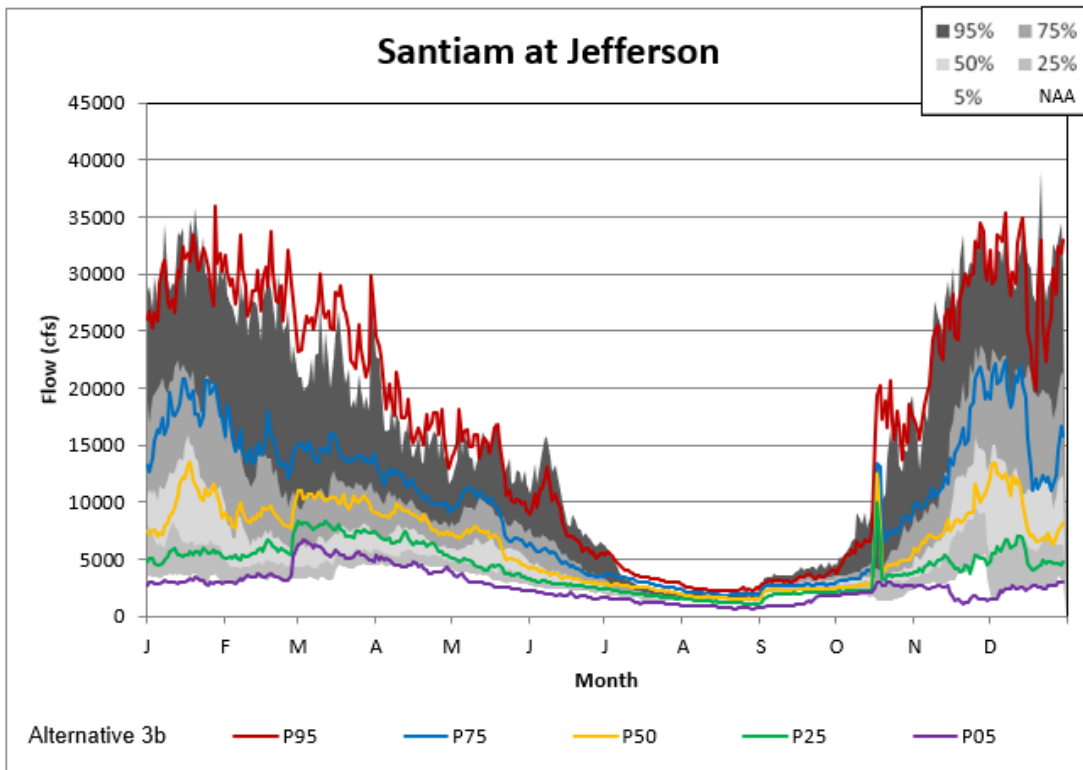

Figure 5-112. Jefferson Alternative 3B Non-exceedance Plot.

Willamette Valley System Operations and Maintenance
Environmental Impact Statement

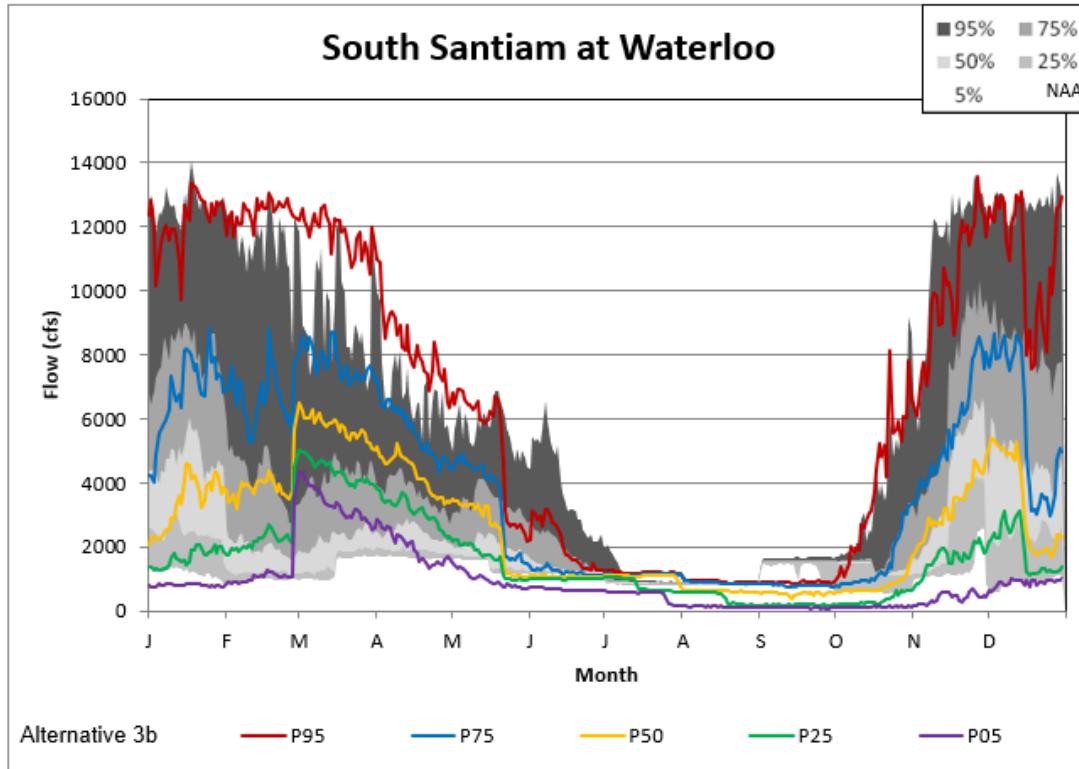

Figure 5-113. Waterloo Alternative 3B Non-exceedance Plot.

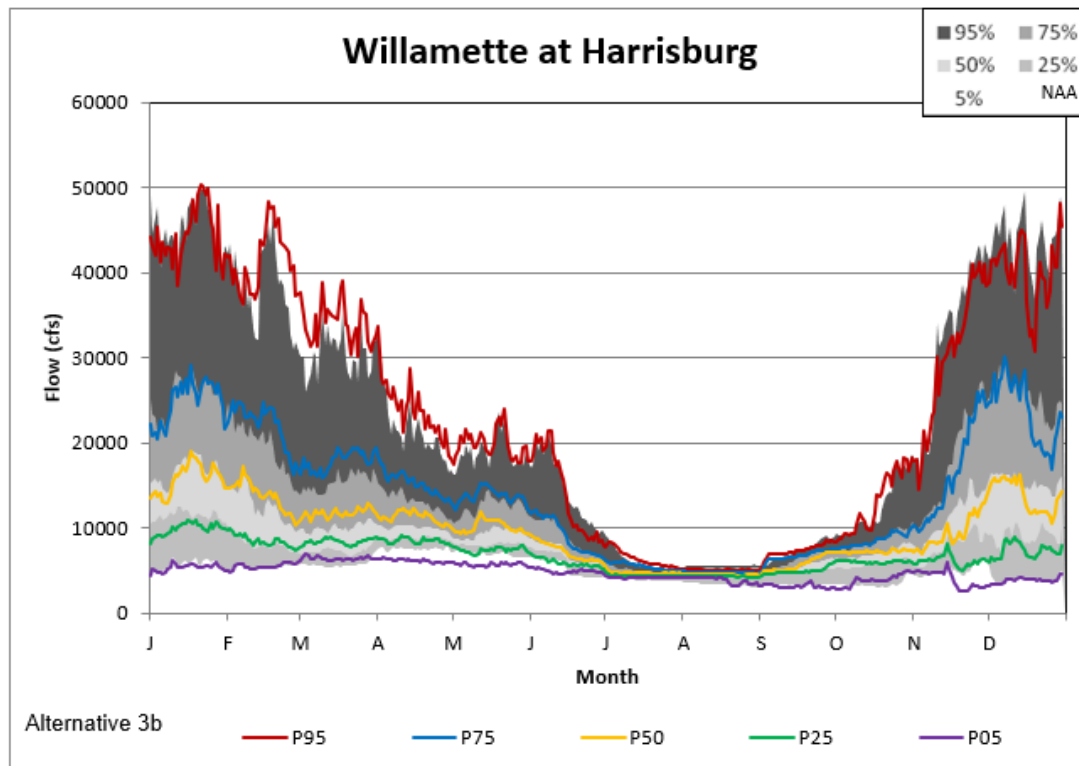

Figure 5-114. Harrisburg Alternative 3B Non-exceedance Plot.

Willamette Valley System Operations and Maintenance
Environmental Impact Statement

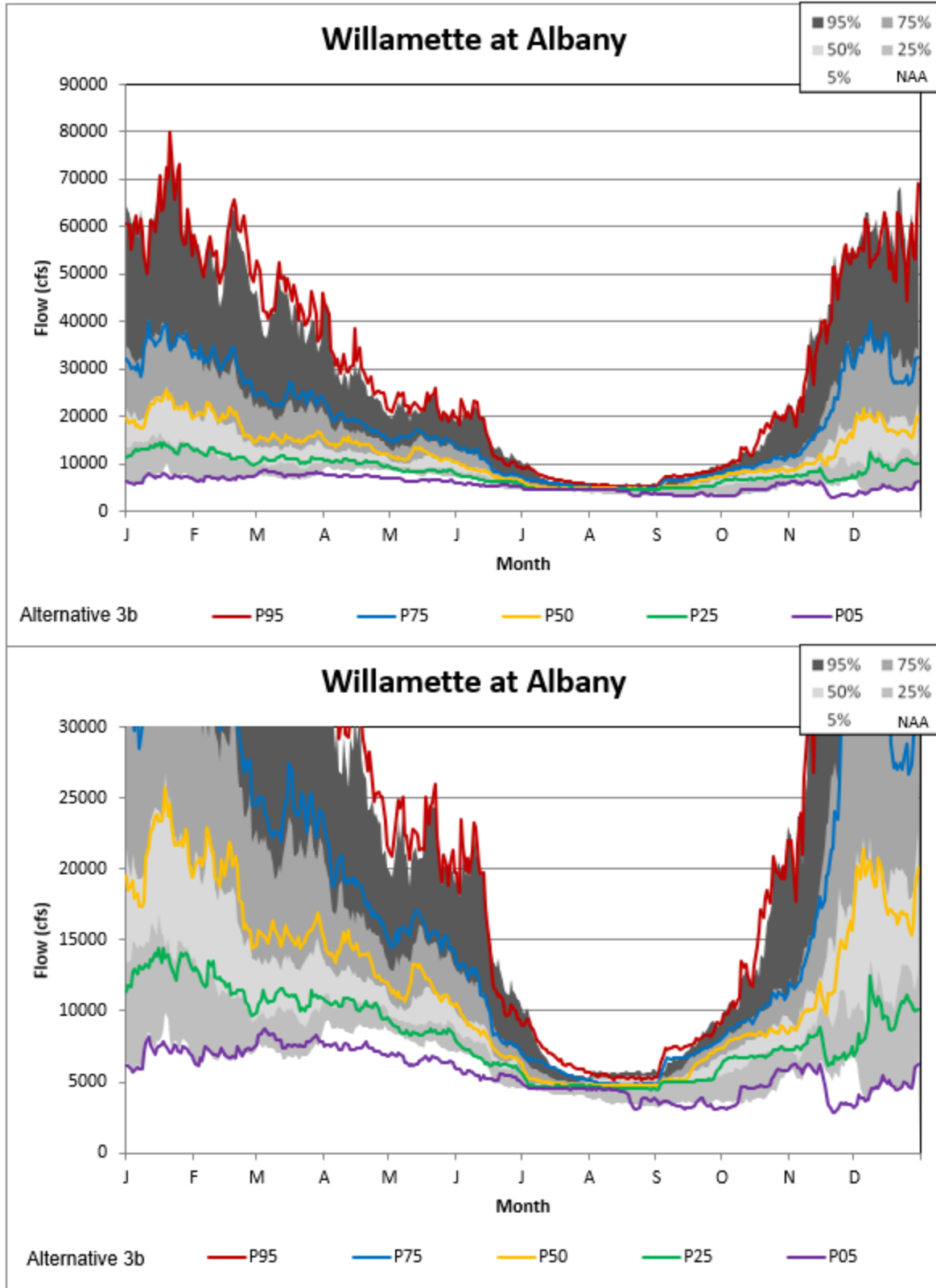

Figure 5-115. Albany Alternative 3B Non-exceedance Plot.

Willamette Valley System Operations and Maintenance
Environmental Impact Statement

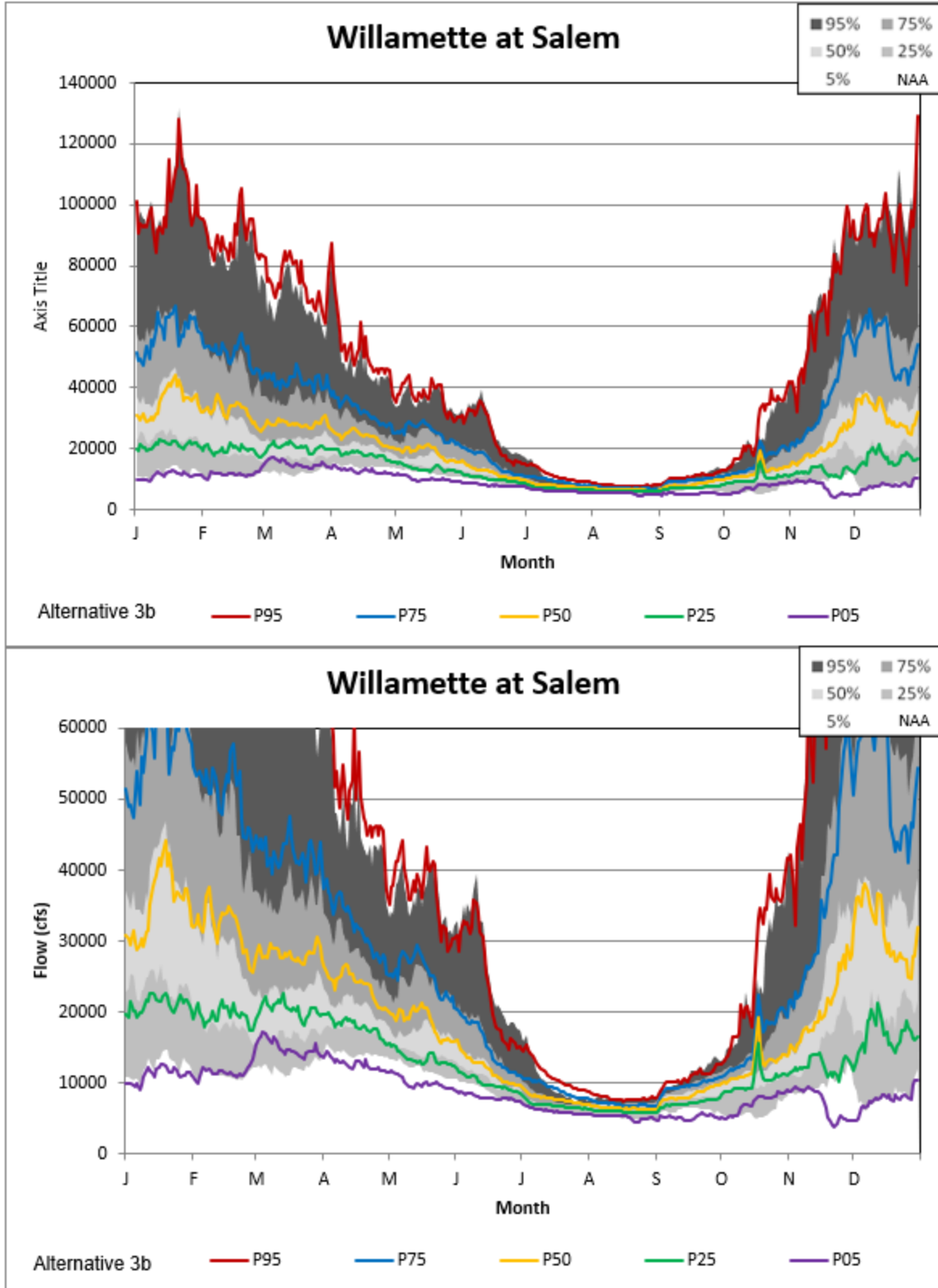

Figure 5-116. Salem Alternative 3B Non-exceedance Plot.

5.6 Alternative 4

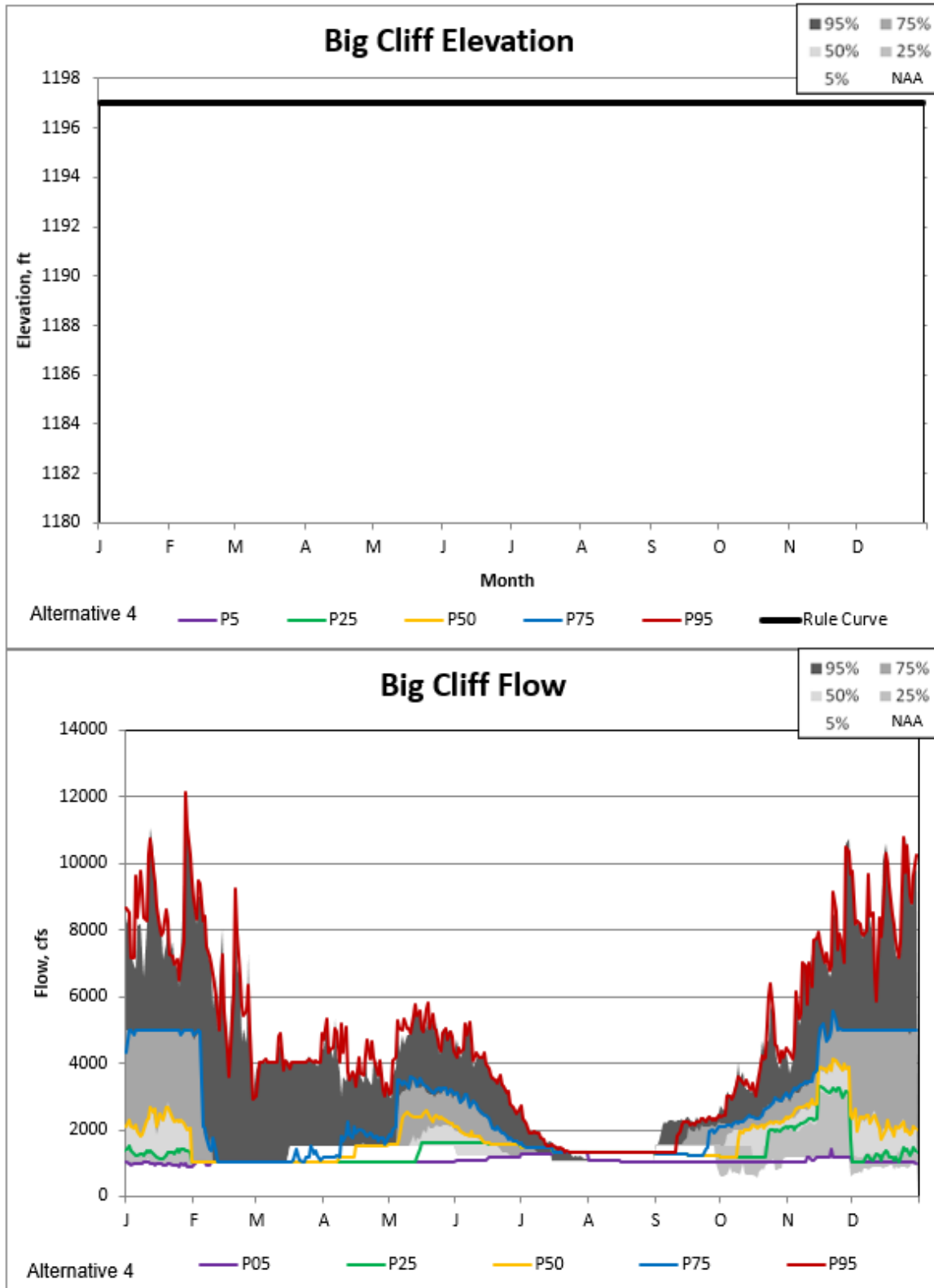

Figure 5-117. Big Cliff Alternative 4 Non-exceedance Plot.

Willamette Valley System Operations and Maintenance
Environmental Impact Statement

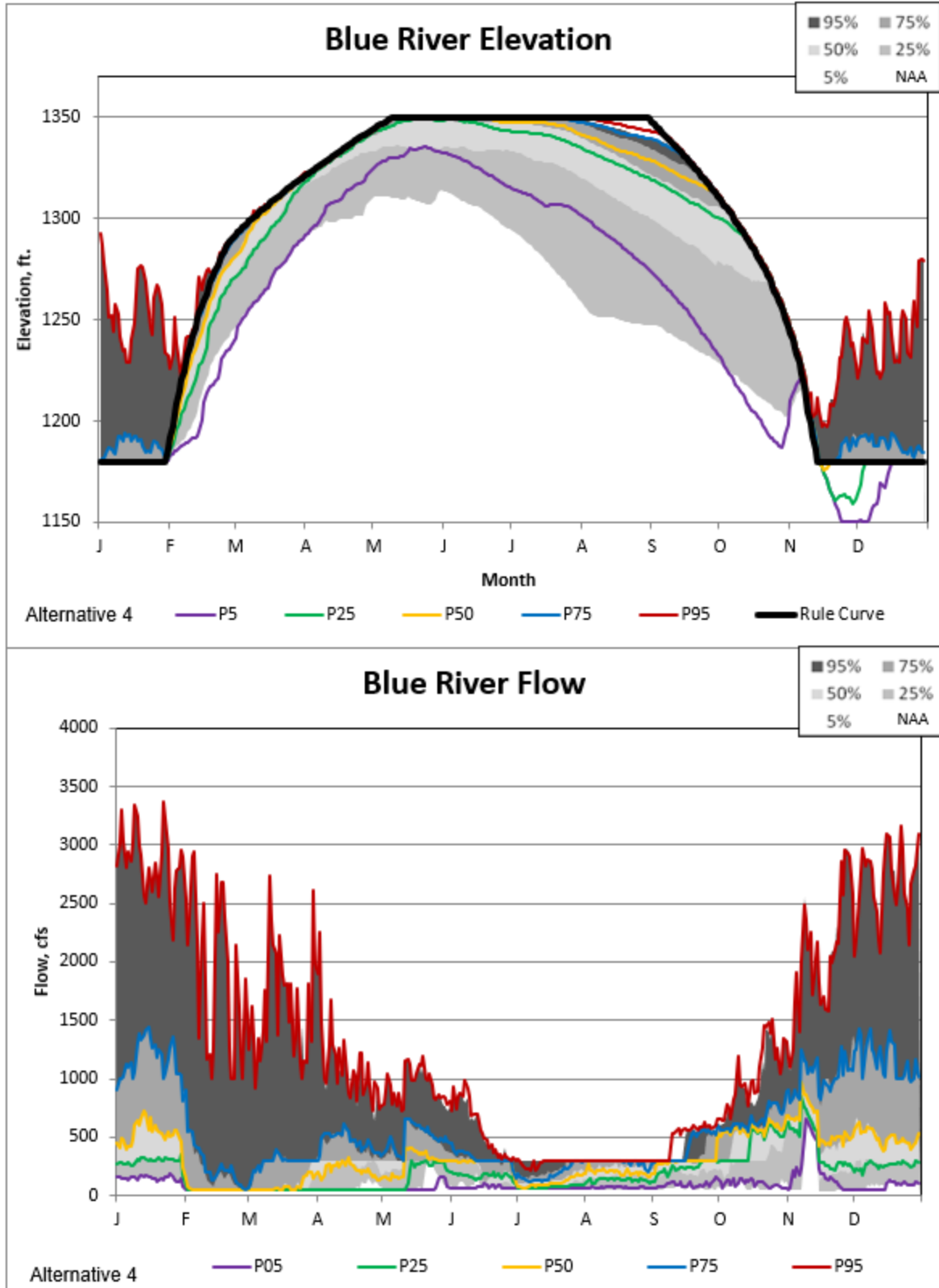

Figure 5-118. Blue River Alternative 4 Non-exceedance Plot.

Willamette Valley System Operations and Maintenance
Environmental Impact Statement

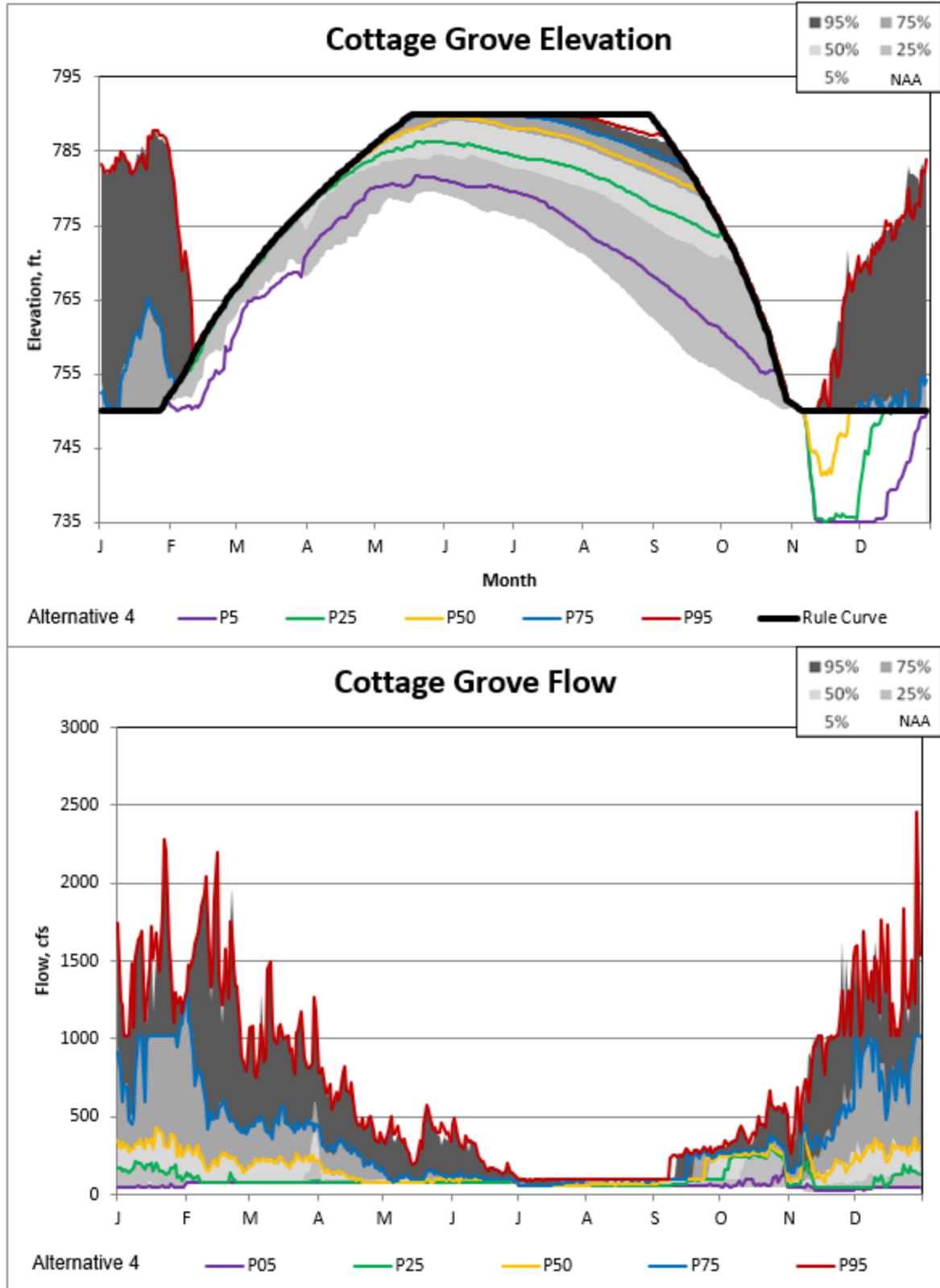

Figure 5-119. Cottage Grove Alternative 4 Non-exceedance Plot.

Willamette Valley System Operations and Maintenance
 Environmental Impact Statement

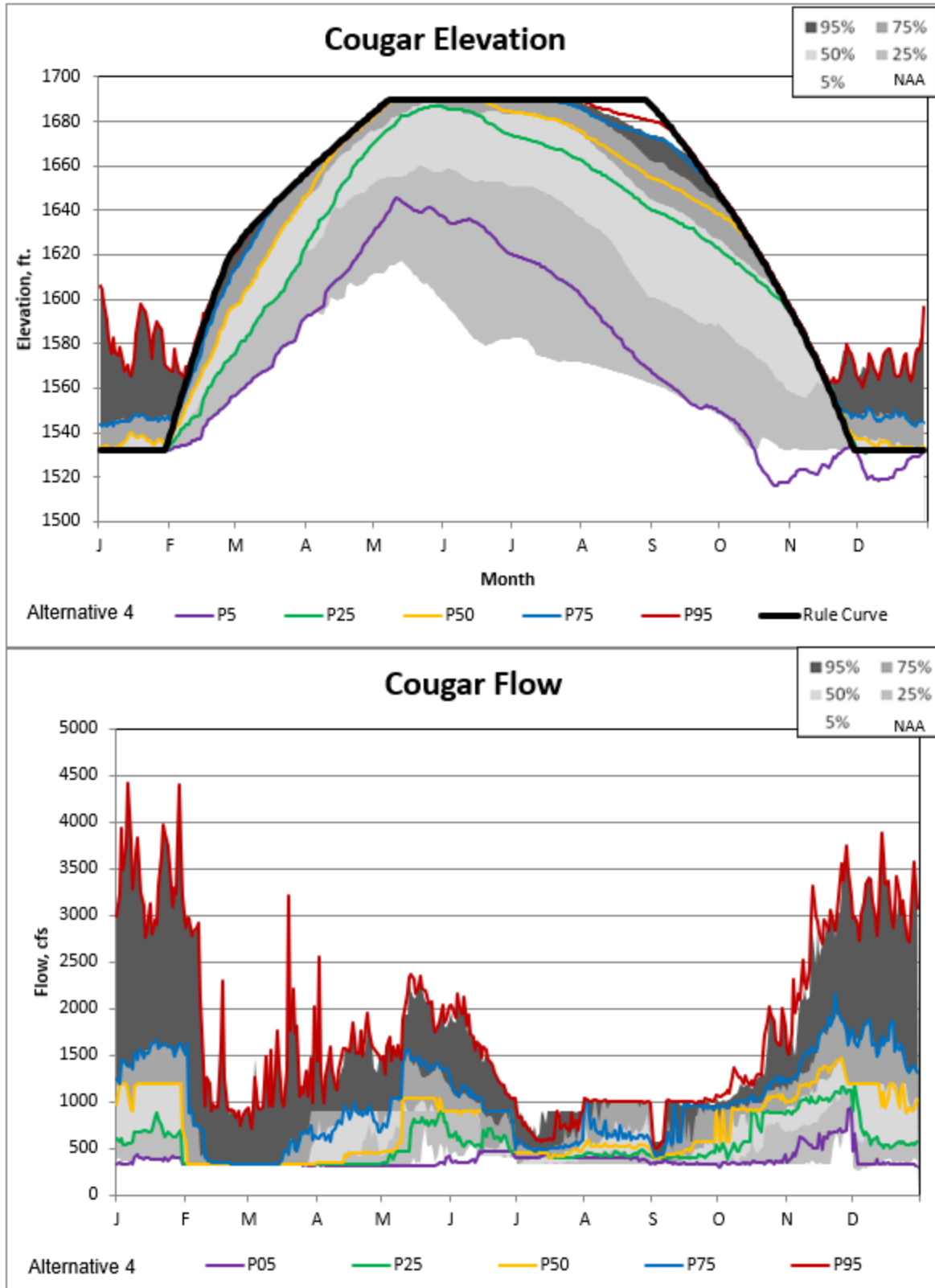

Figure 5-120. Cougar Alternative 4 Non-exceedance Plot.

*Willamette Valley System Operations and Maintenance
Environmental Impact Statement*

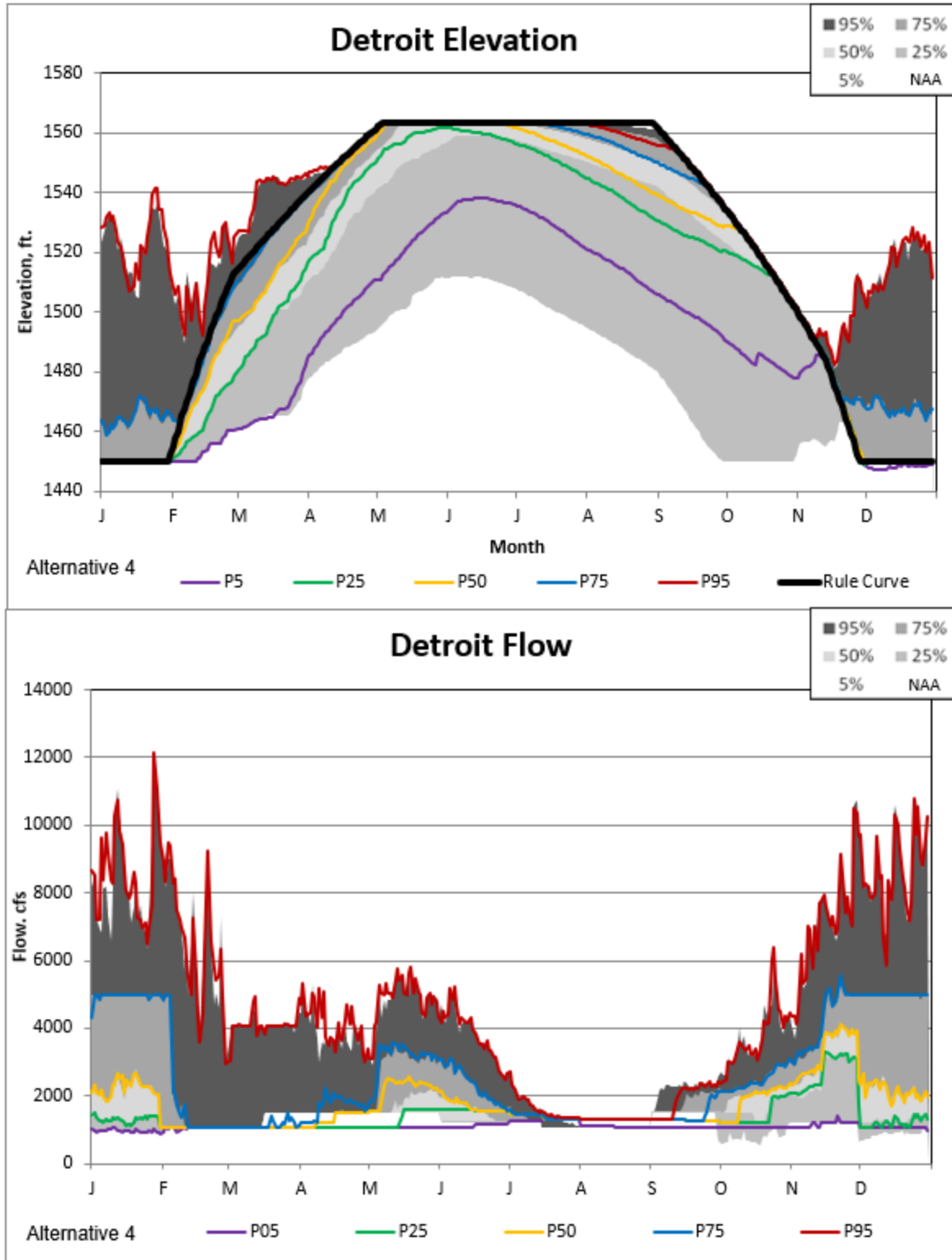

Figure 5-121. Detroit Alternative 4 Non-exceedance Plot.

*Willamette Valley System Operations and Maintenance
Environmental Impact Statement*

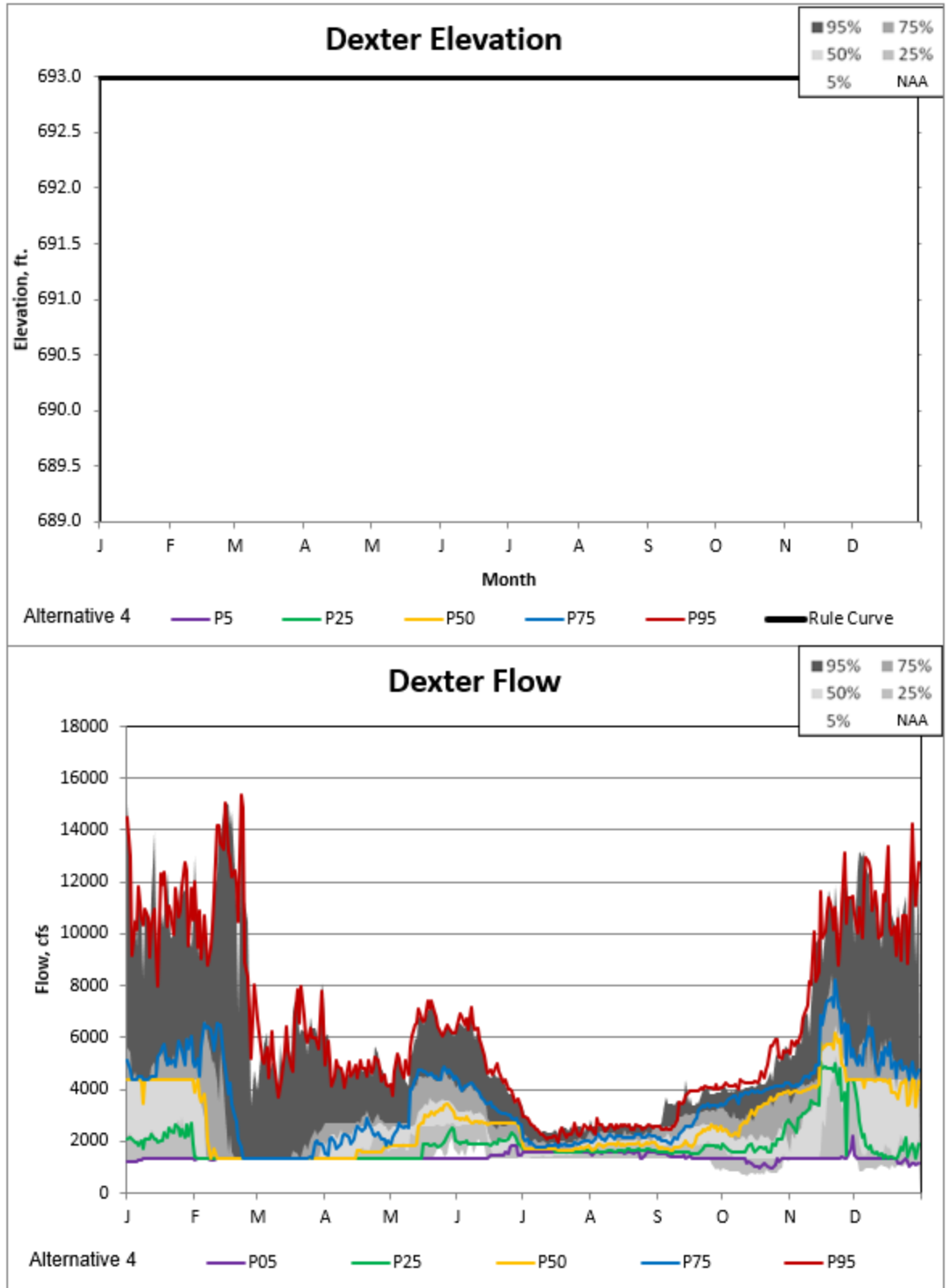

Figure 5-122. Dexter Alternative 4 Non-exceedance Plot.

Willamette Valley System Operations and Maintenance
Environmental Impact Statement

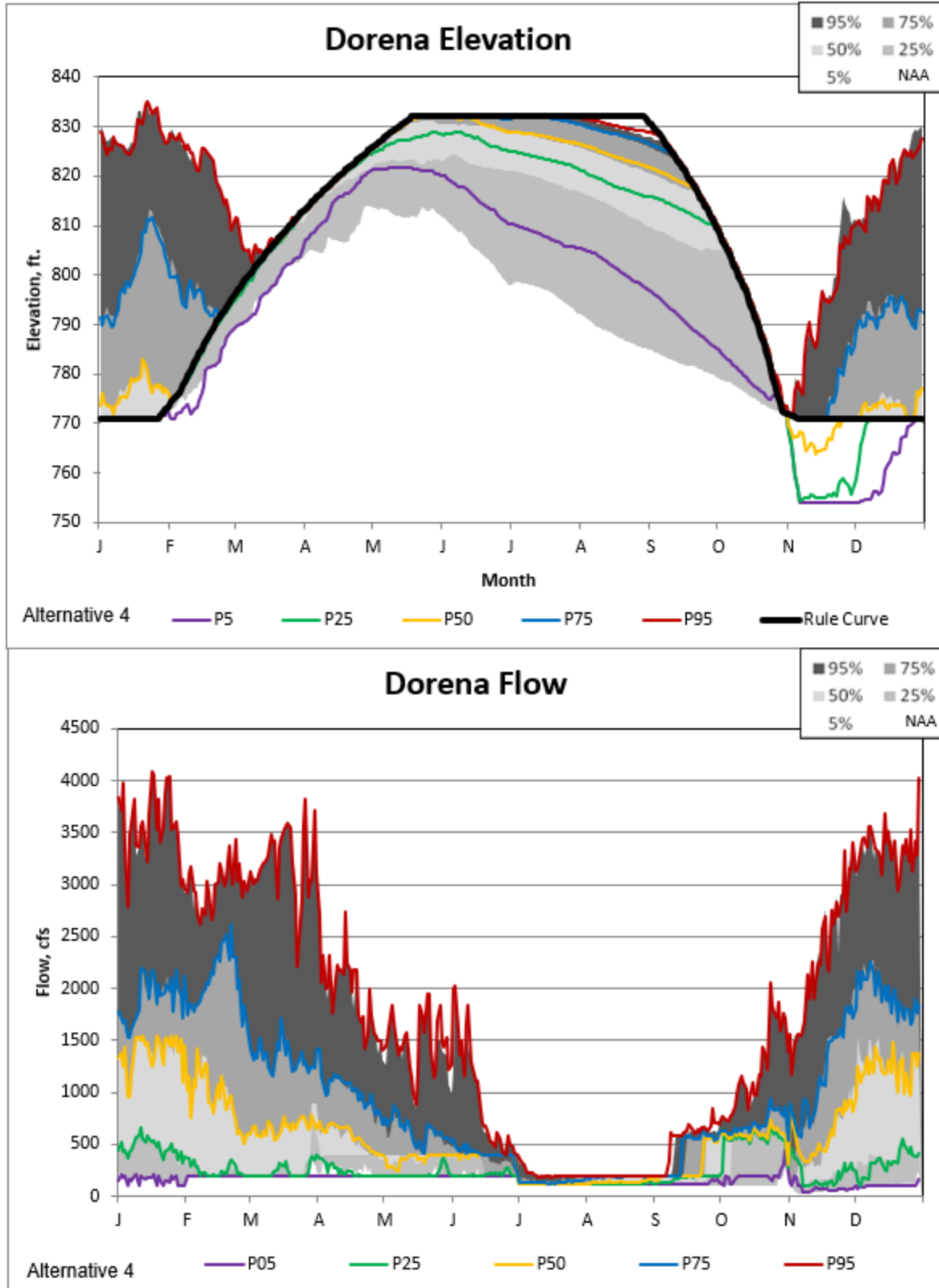

Figure 5-123. Dorena Alternative 4 Non-exceedance Plot.

Willamette Valley System Operations and Maintenance
Environmental Impact Statement

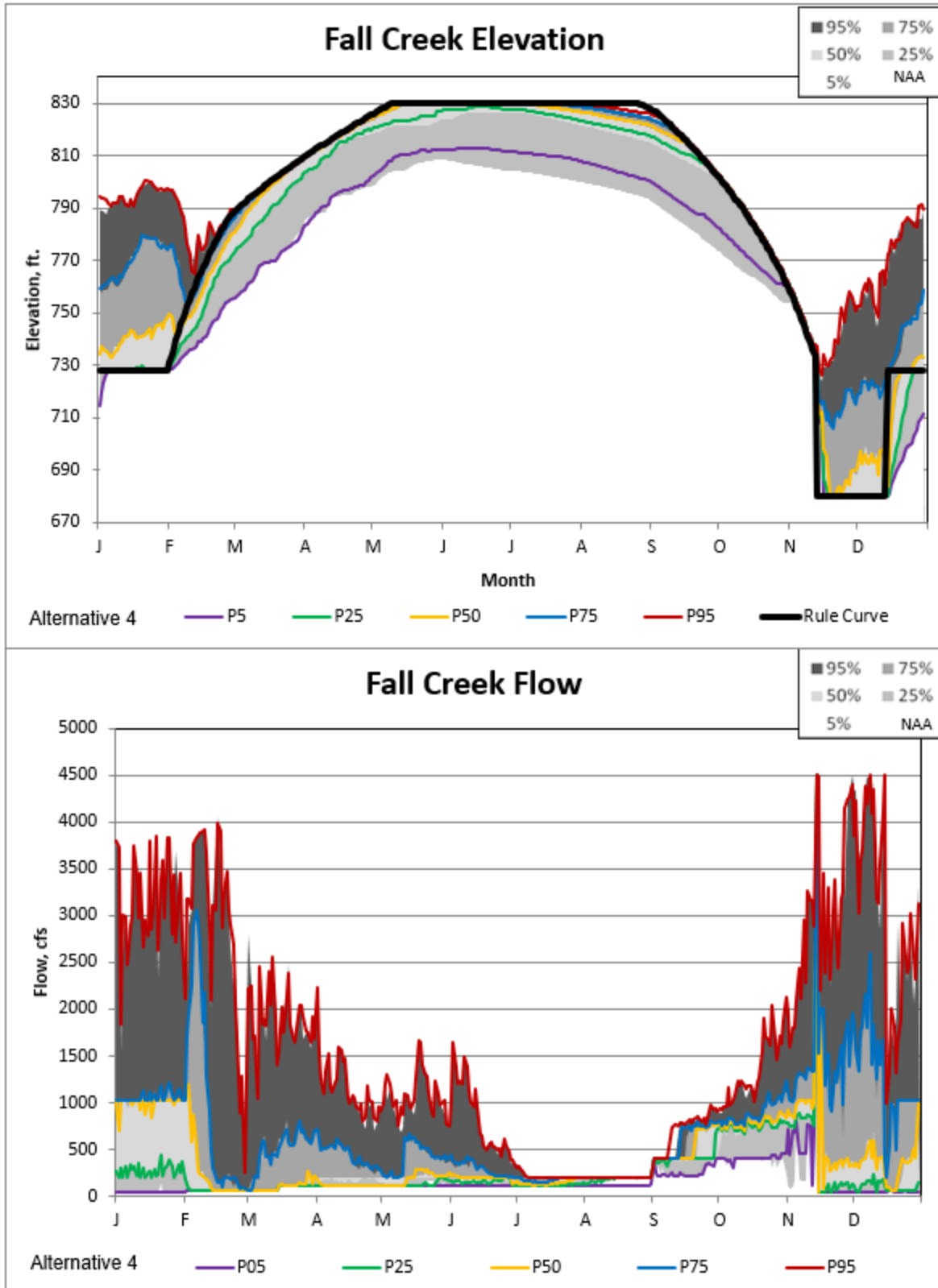

Figure 5-124. Fall Creek Alternative 4 Non-exceedance Plot.

Willamette Valley System Operations and Maintenance
Environmental Impact Statement

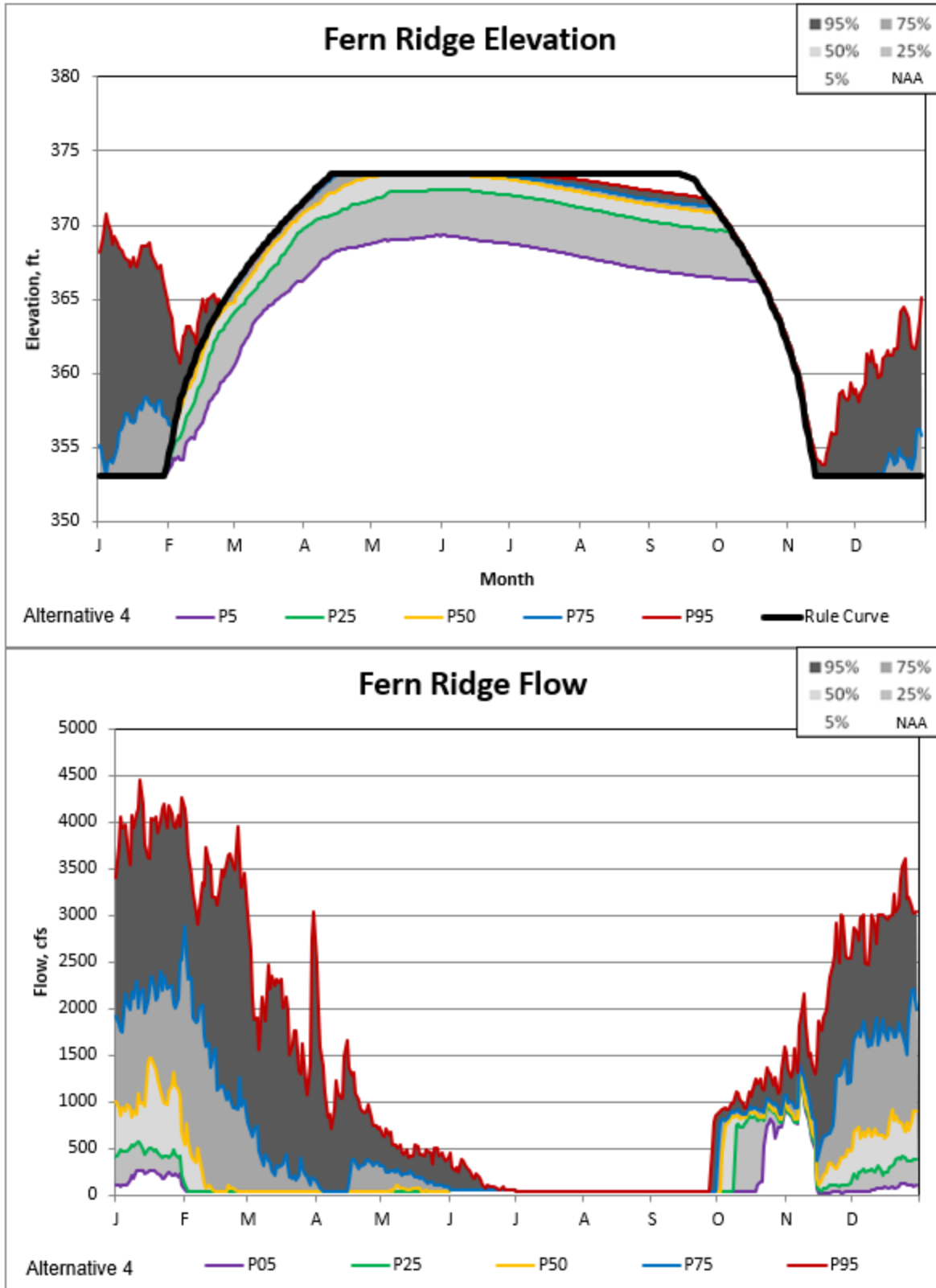

Figure 5-125. Fern Ridge Alternative 4 Non-exceedance Plot.

Willamette Valley System Operations and Maintenance
Environmental Impact Statement

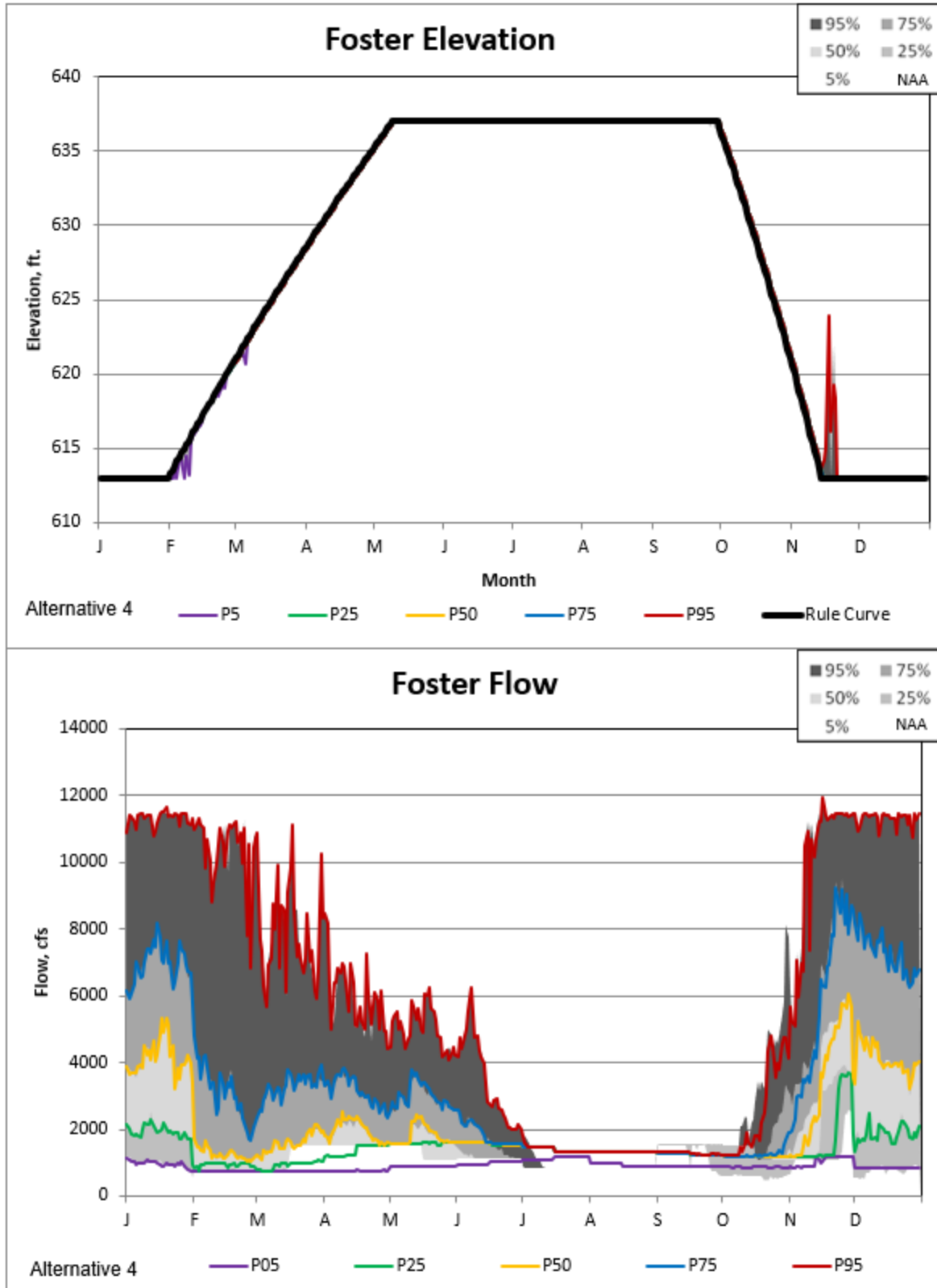

Figure 5-126. Foster Alternative 4 Non-exceedance Plot.

Willamette Valley System Operations and Maintenance
Environmental Impact Statement

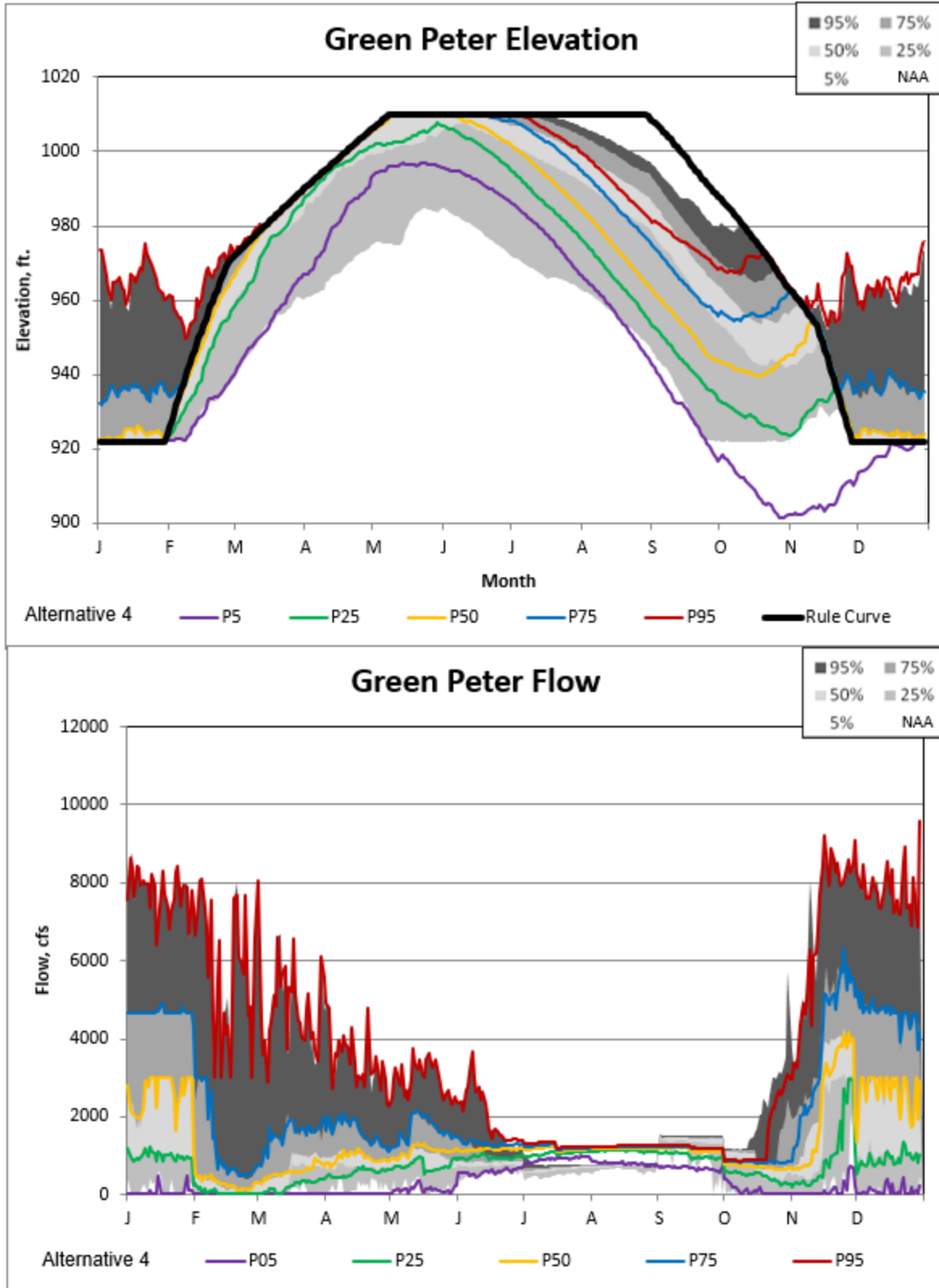

Figure 5-127. Green Peter Alternative 4 Non-exceedance Plot.

Willamette Valley System Operations and Maintenance
Environmental Impact Statement

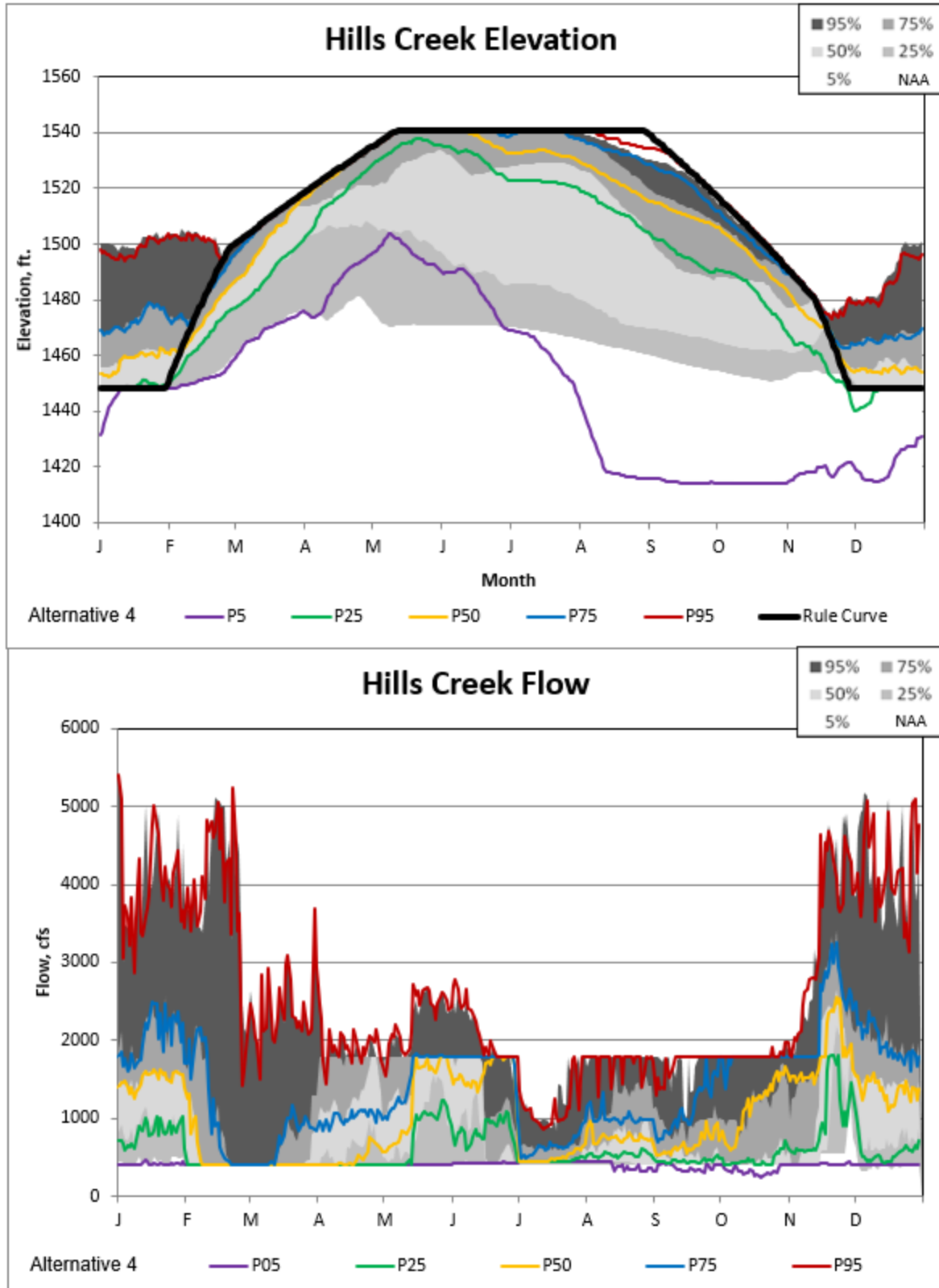

Figure 5-128. Hills Creek Alternative 4 Non-exceedance Plot.

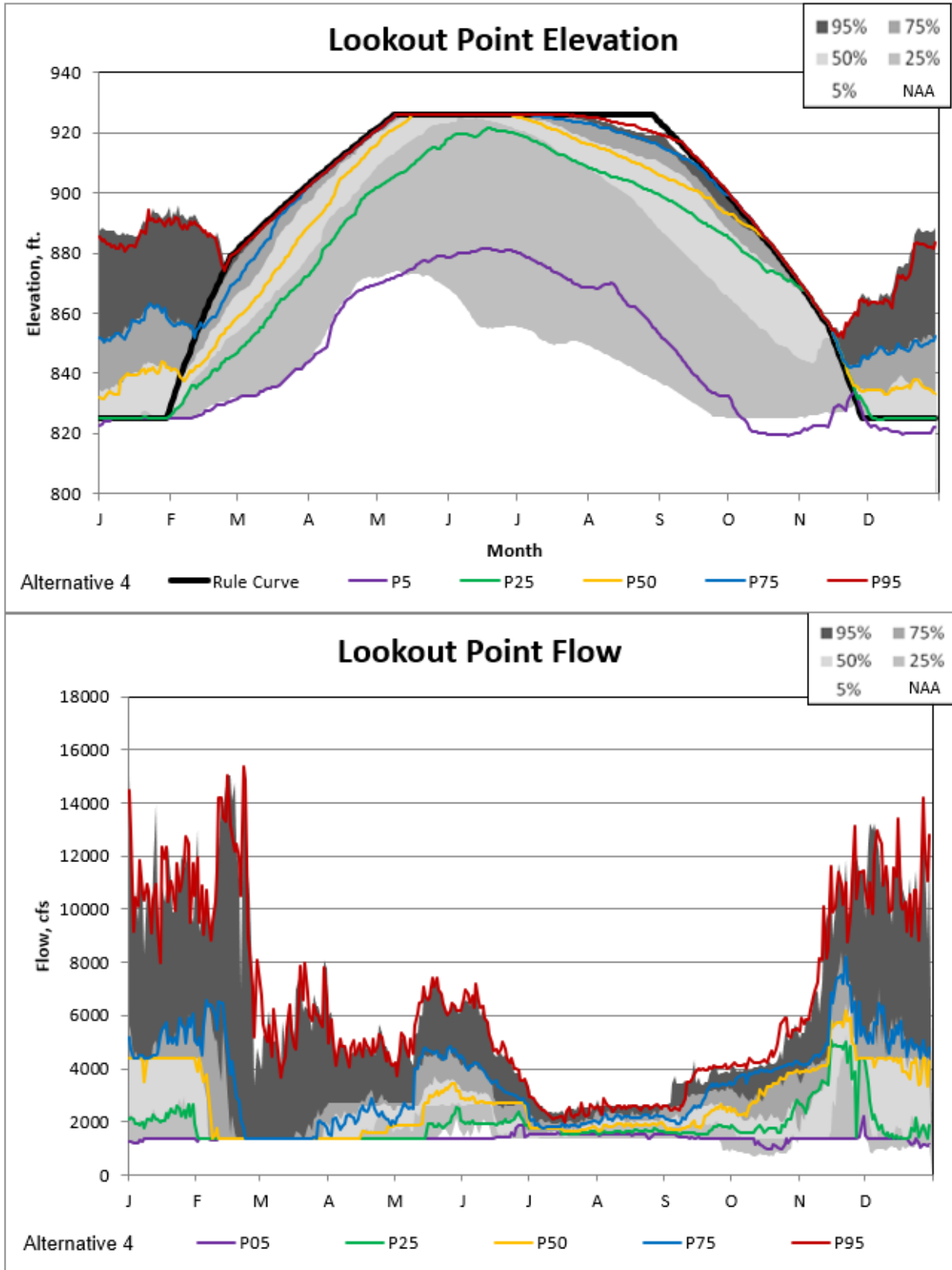

Figure 5-129. Lookout Point Alternative 4 Non-exceedance Plot.

Willamette Valley System Operations and Maintenance
Environmental Impact Statement

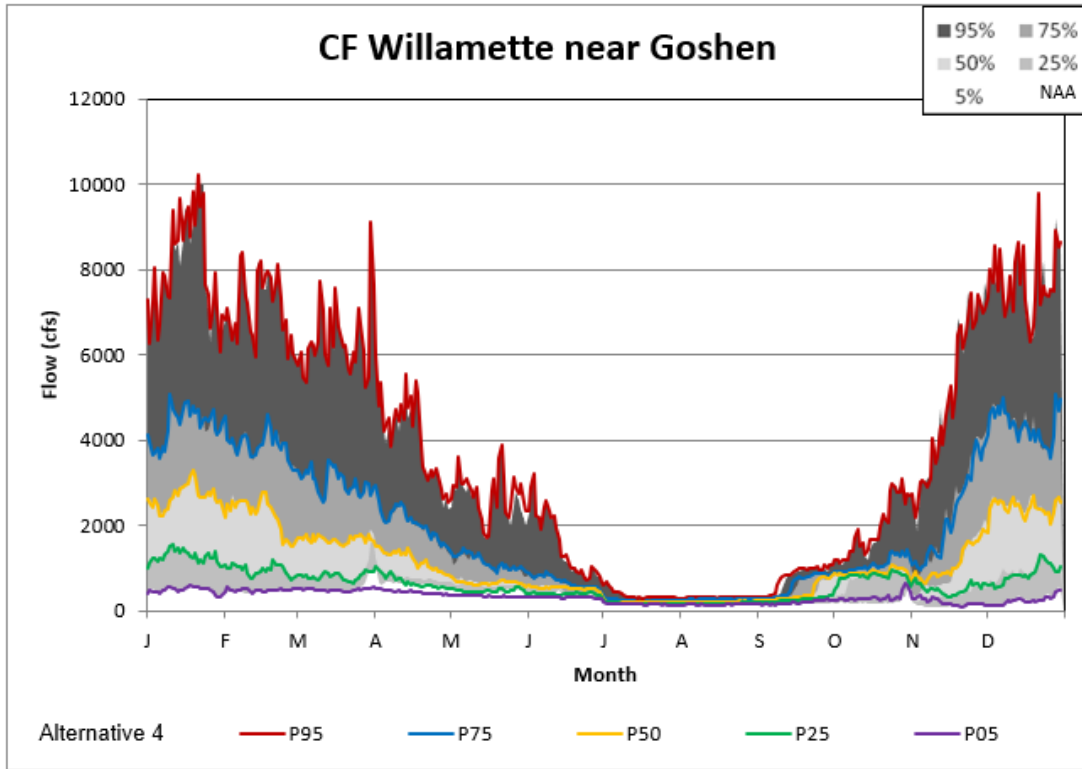

Figure 5-130. Goshen Alternative 4 Non-exceedance Plot.

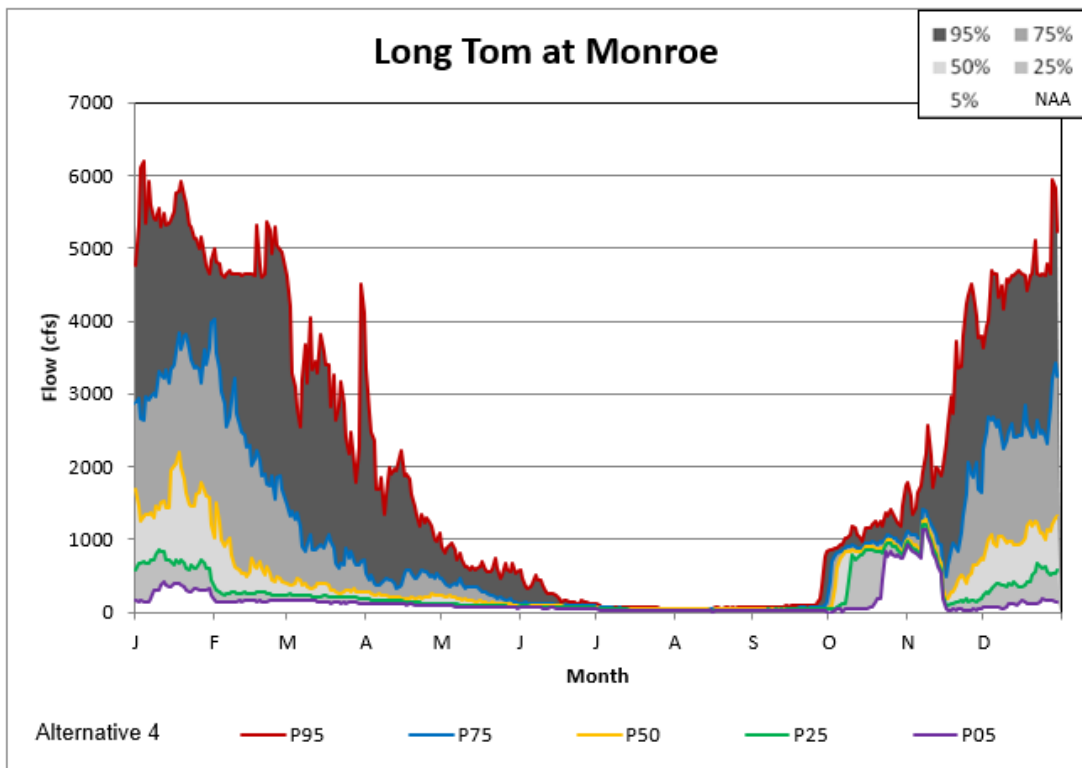

Figure 5-131. Monroe Alternative 4 Non-exceedance Plot.

Willamette Valley System Operations and Maintenance
Environmental Impact Statement

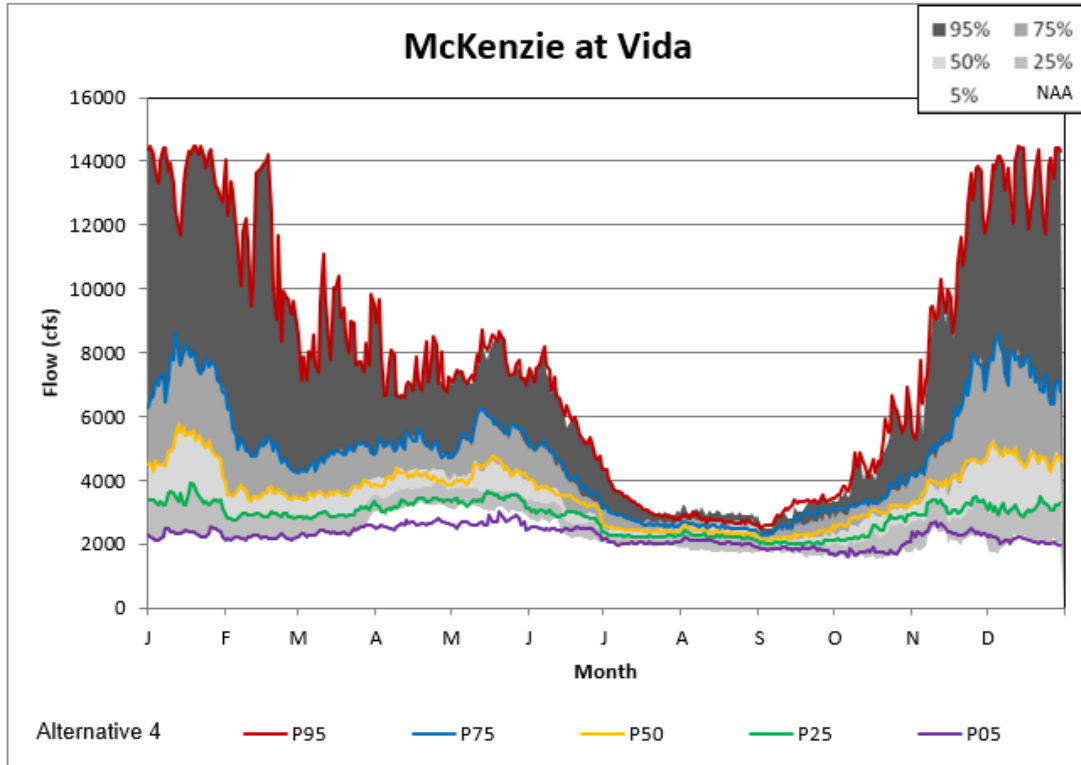

Figure 5-132. Vida Alternative 4 Non-exceedance Plot.

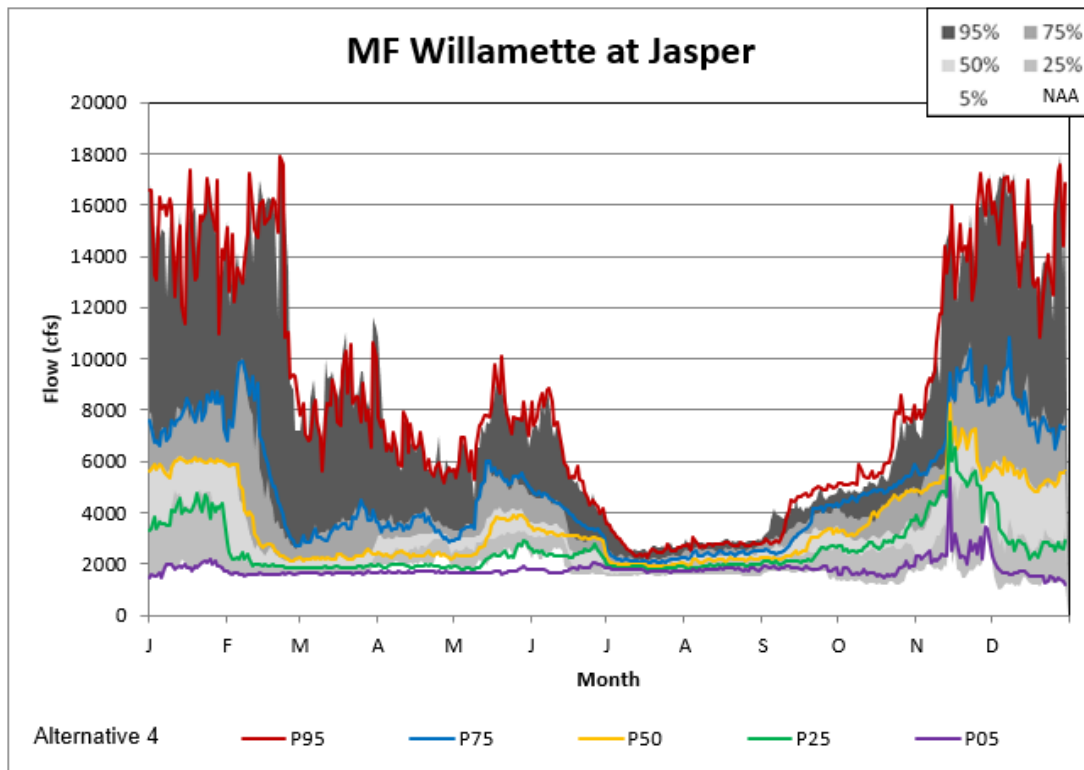

Figure 5-133. Jasper Alternative 4 Non-exceedance Plot.

Willamette Valley System Operations and Maintenance
Environmental Impact Statement

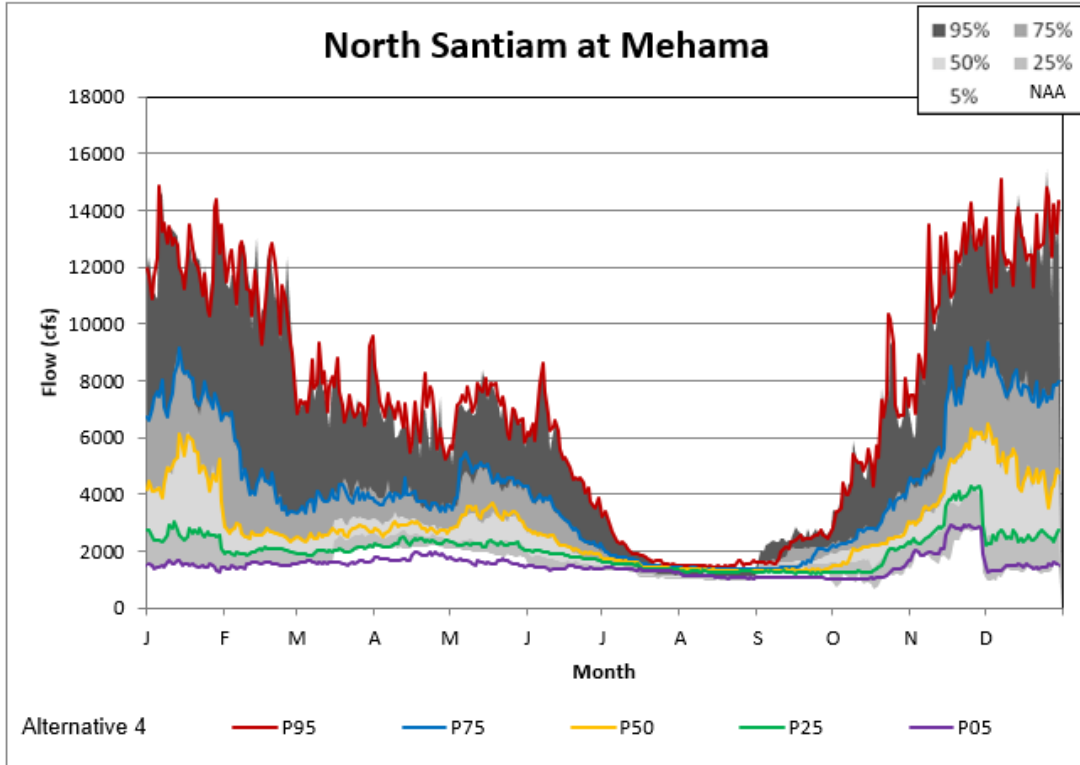

Figure 5-134. Mehama Alternative 4 Non-exceedance Plot.

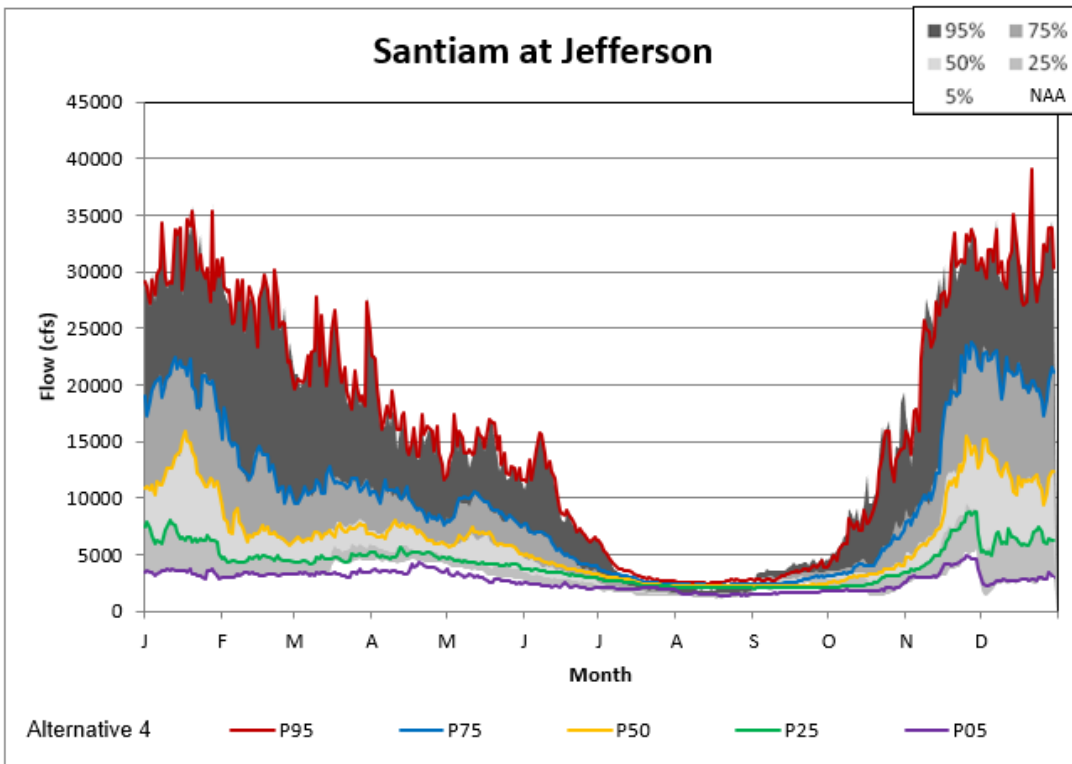

Figure 5-135. Jefferson Alternative 4 Non-exceedance Plot.

Willamette Valley System Operations and Maintenance
Environmental Impact Statement

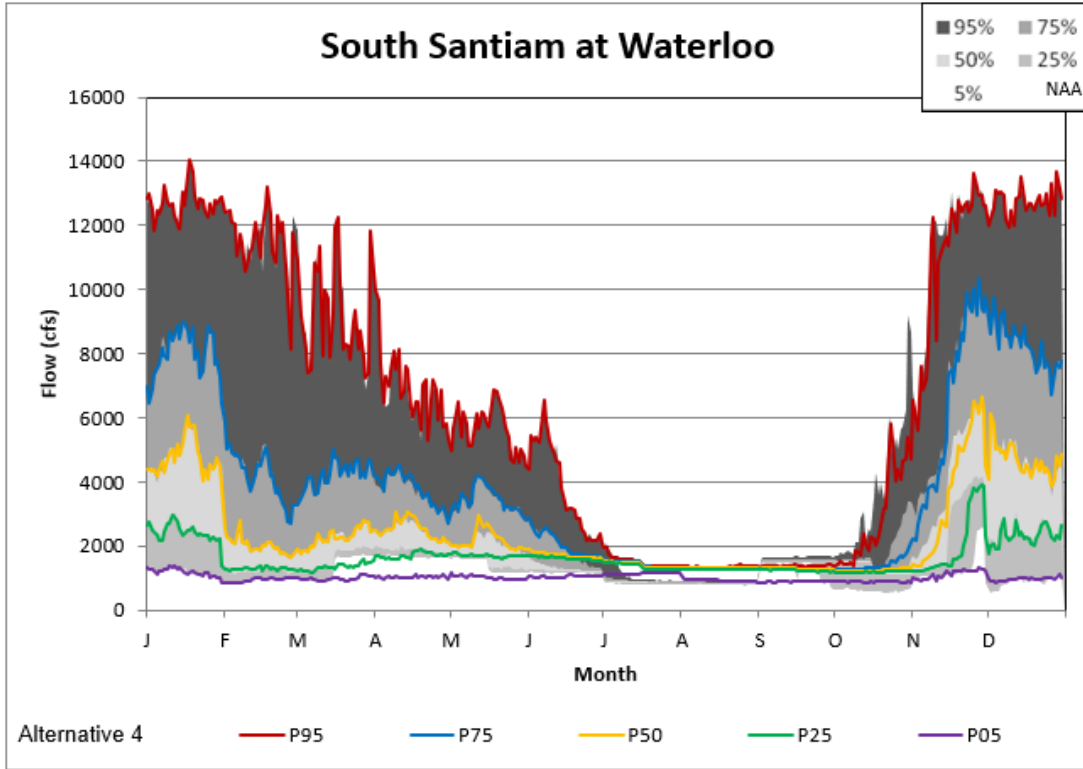

Figure 5-136. Waterloo Alternative 4 Non-exceedance Plot.

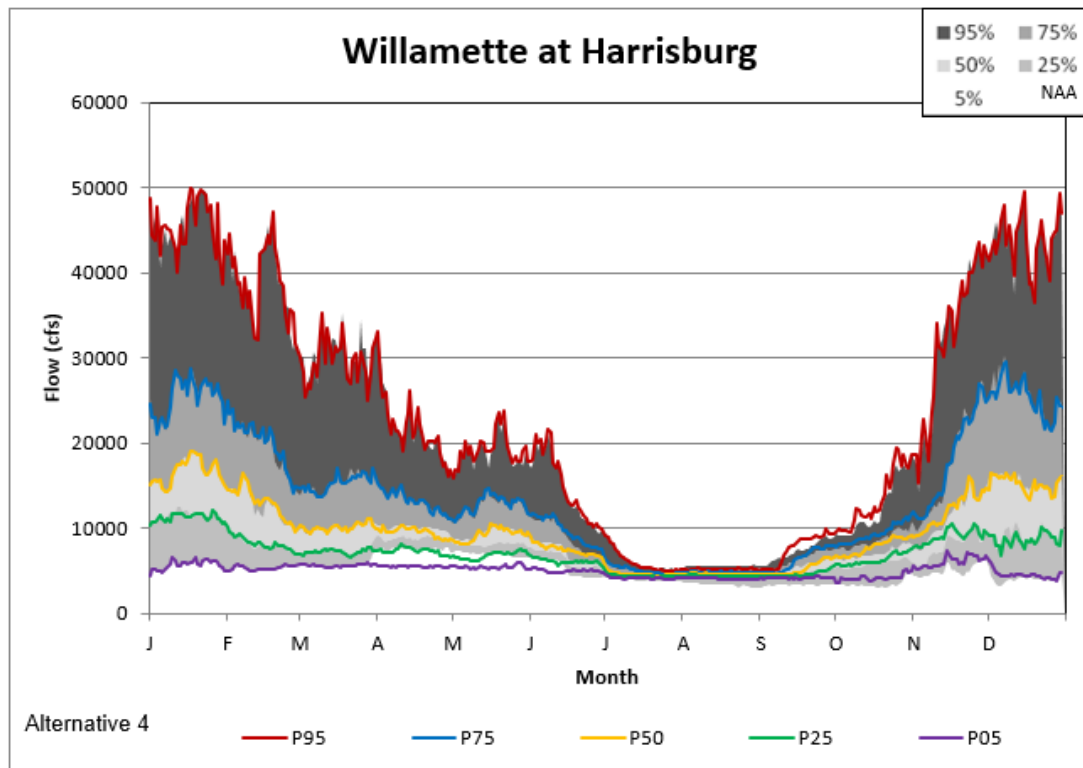

Figure 5-137. Harrisburg Alternative 4 Non-exceedance Plot.

Willamette Valley System Operations and Maintenance
Environmental Impact Statement

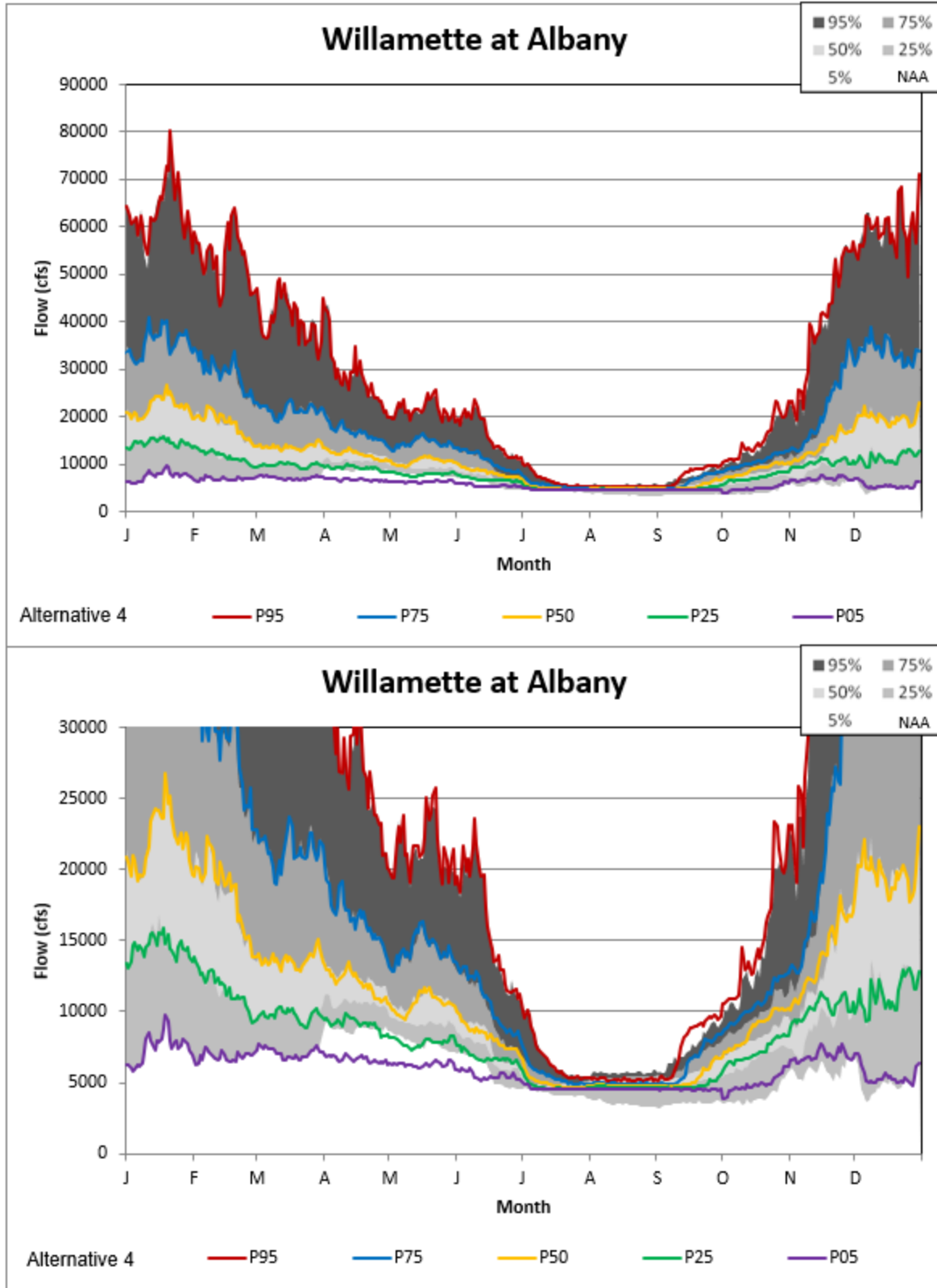

Figure 5-138. Albany Alternative 4 Non-exceedance Plot.

Willamette Valley System Operations and Maintenance
Environmental Impact Statement

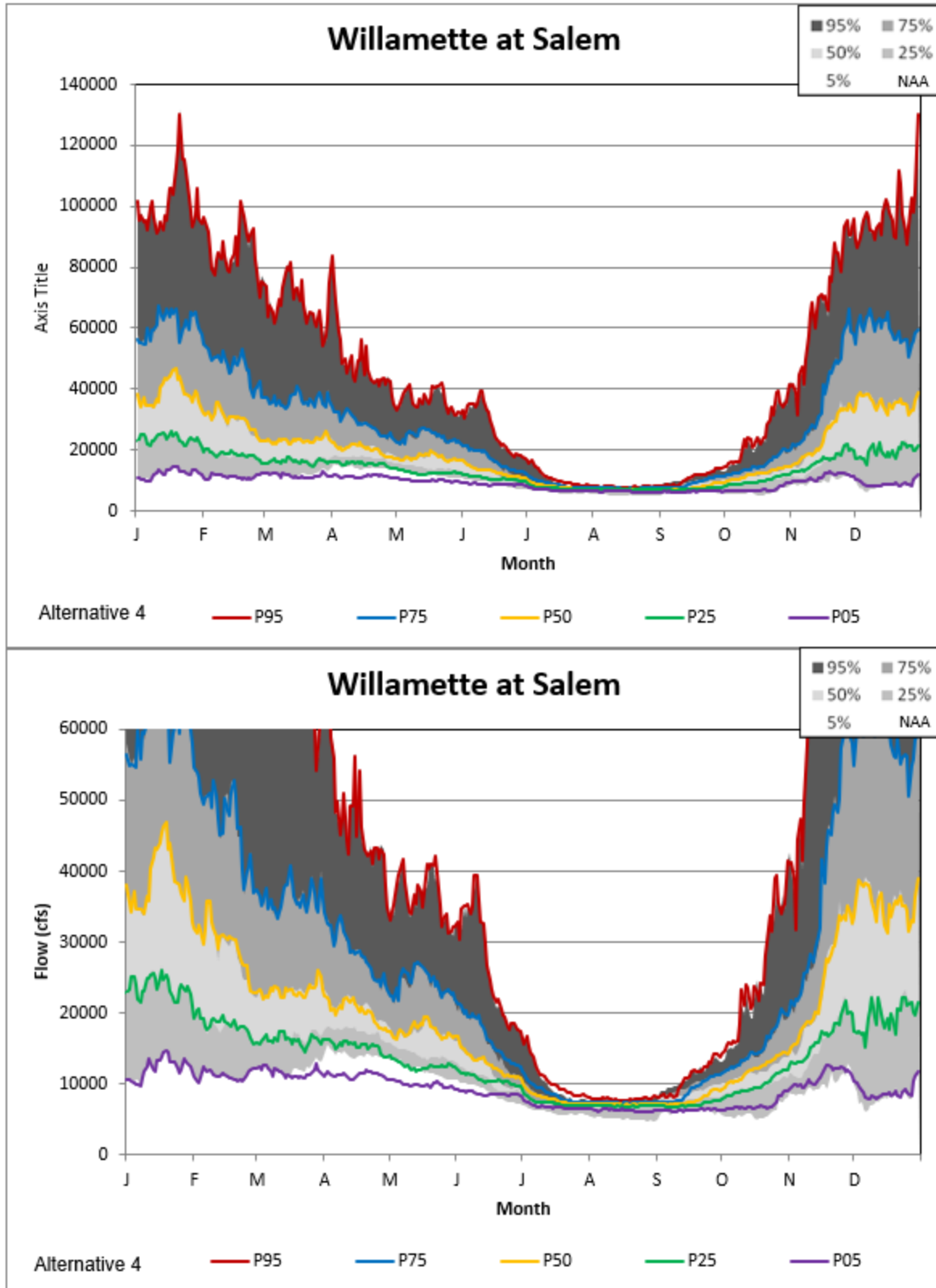

Figure 5-139. Salem Alternative 4 Non-exceedance Plot.

5.7 Alternative 5

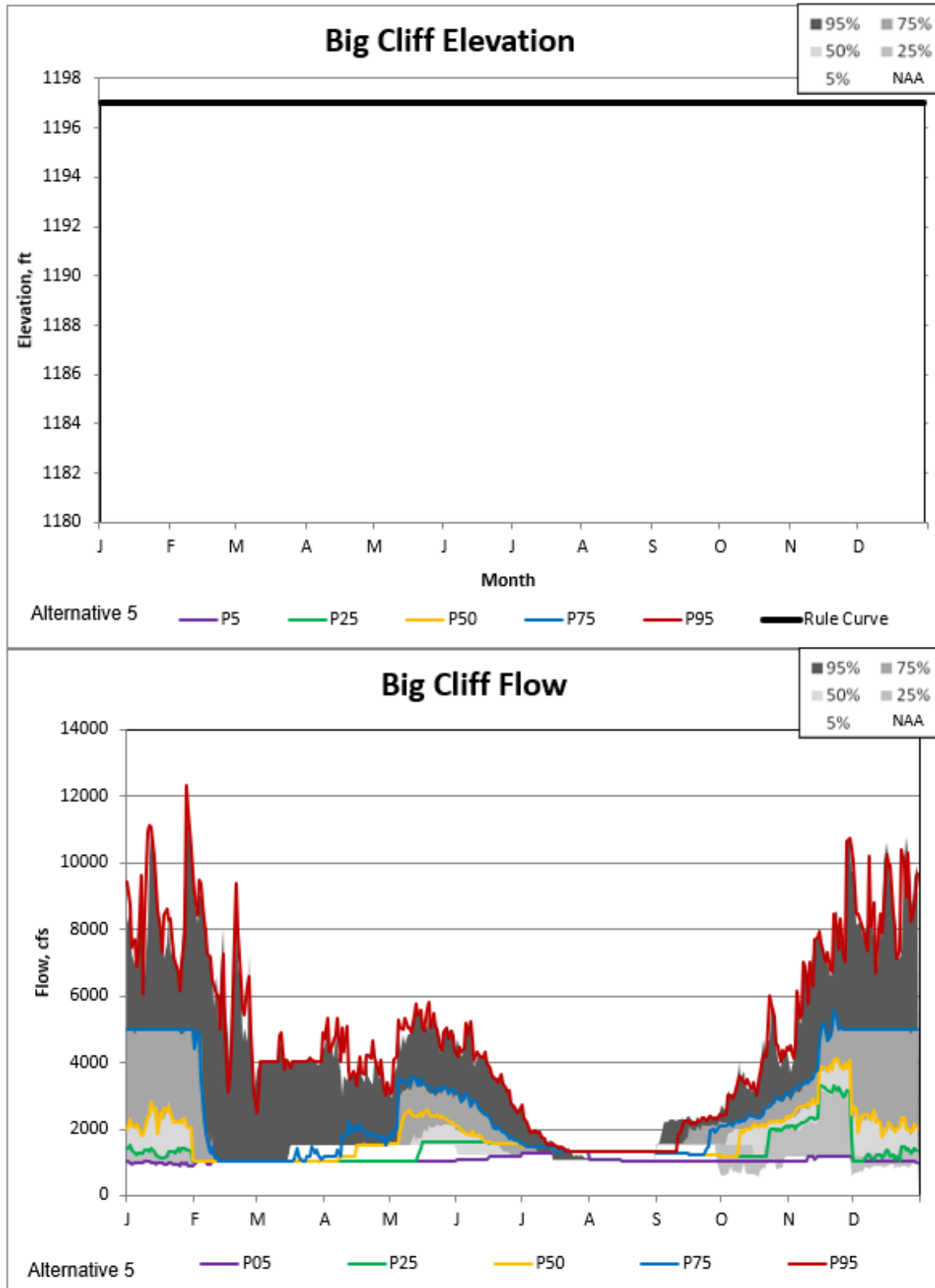

Figure 5-140. Big Cliff Alternative 5 Non-exceedance Plot.

Willamette Valley System Operations and Maintenance
Environmental Impact Statement

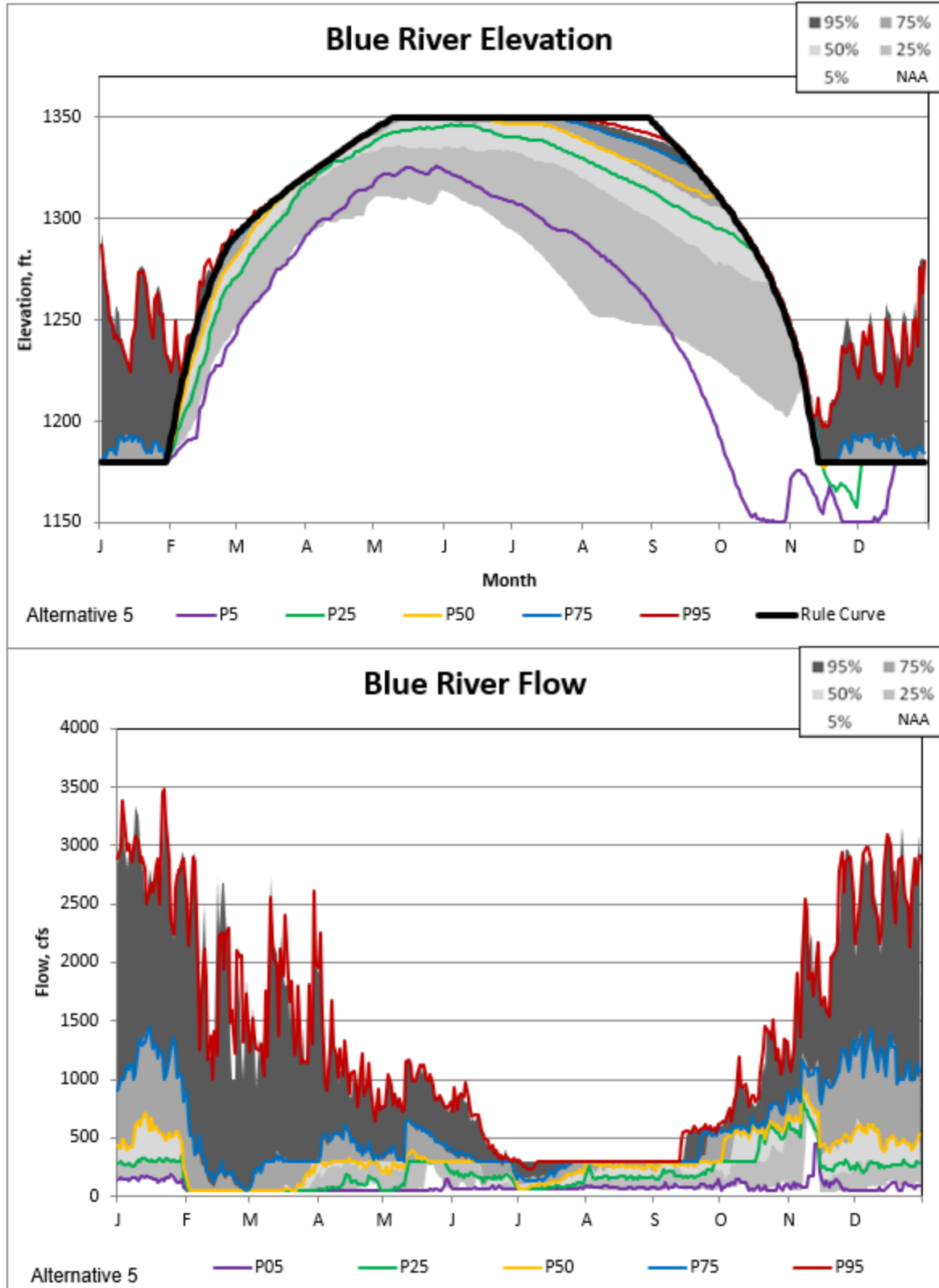

Figure 5-141. Blue River Alternative 5 Non-exceedance Plot.

Willamette Valley System Operations and Maintenance
Environmental Impact Statement

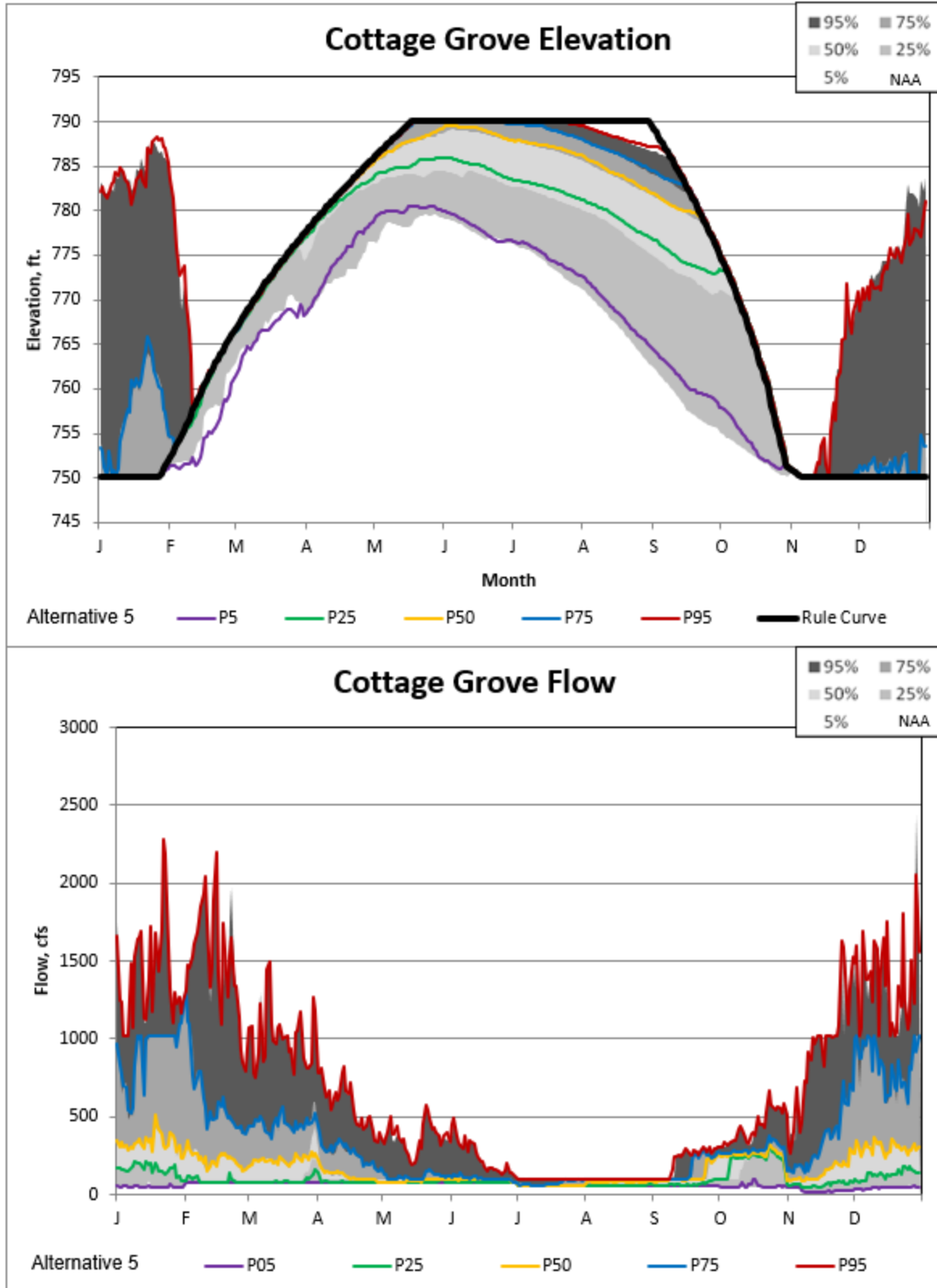

Figure 5-142. Cottage Grove Alternative 5 Non-exceedance Plot.

Willamette Valley System Operations and Maintenance
Environmental Impact Statement

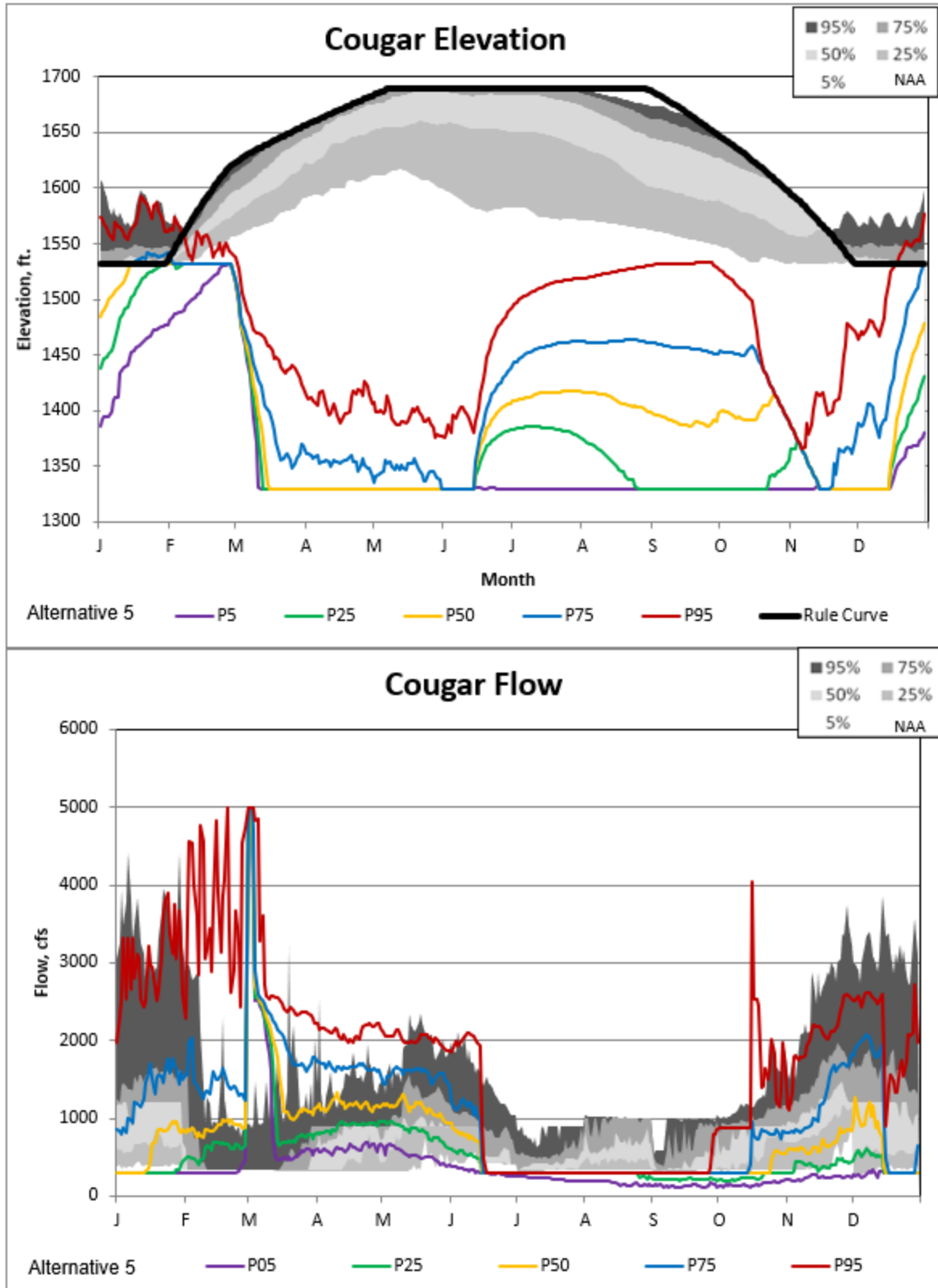

Figure 5-143. Cougar Alternative 5 Non-exceedance Plot.

Willamette Valley System Operations and Maintenance
Environmental Impact Statement

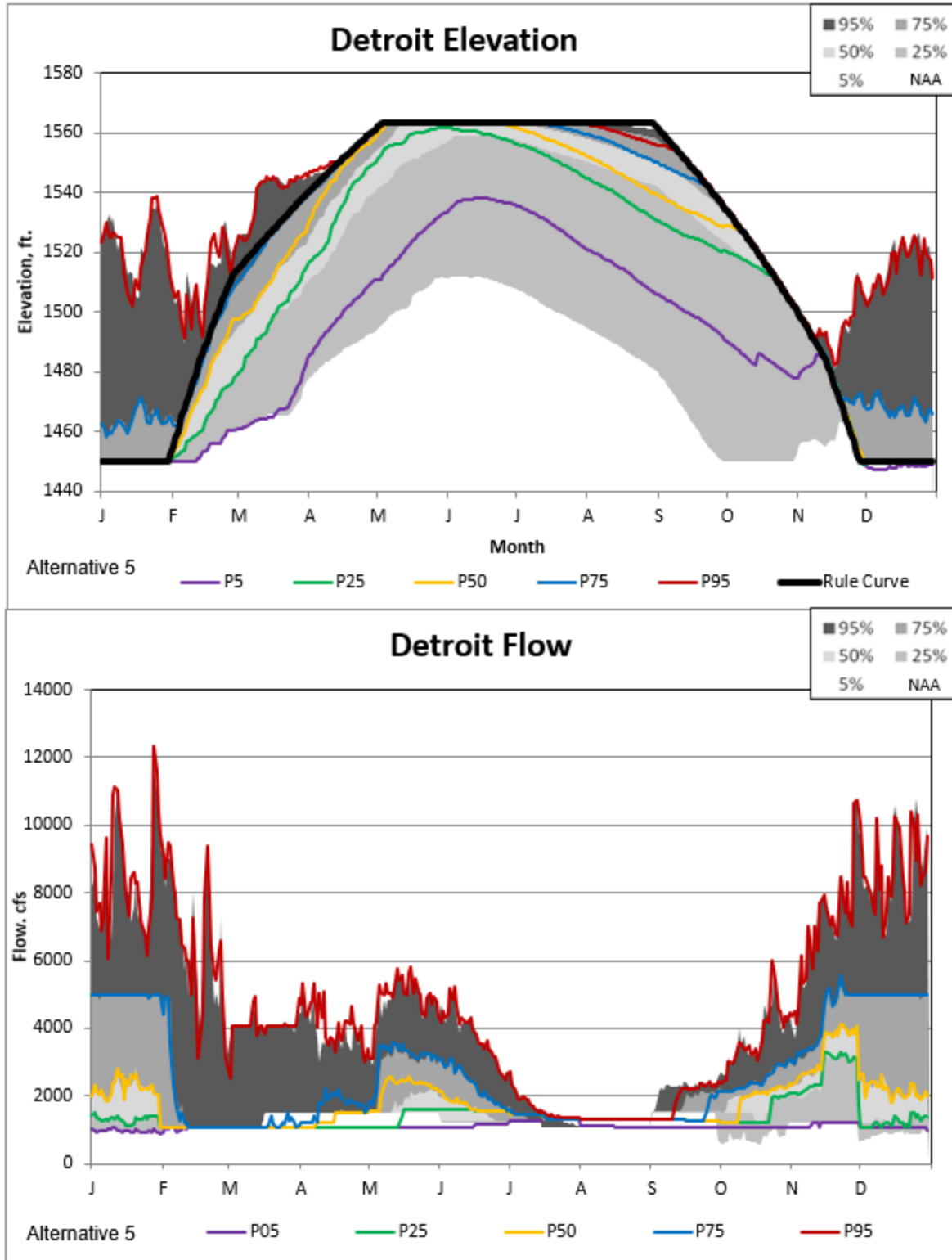

Figure 5-144. Detroit Alternative 5 Non-exceedance Plot.

Willamette Valley System Operations and Maintenance
Environmental Impact Statement

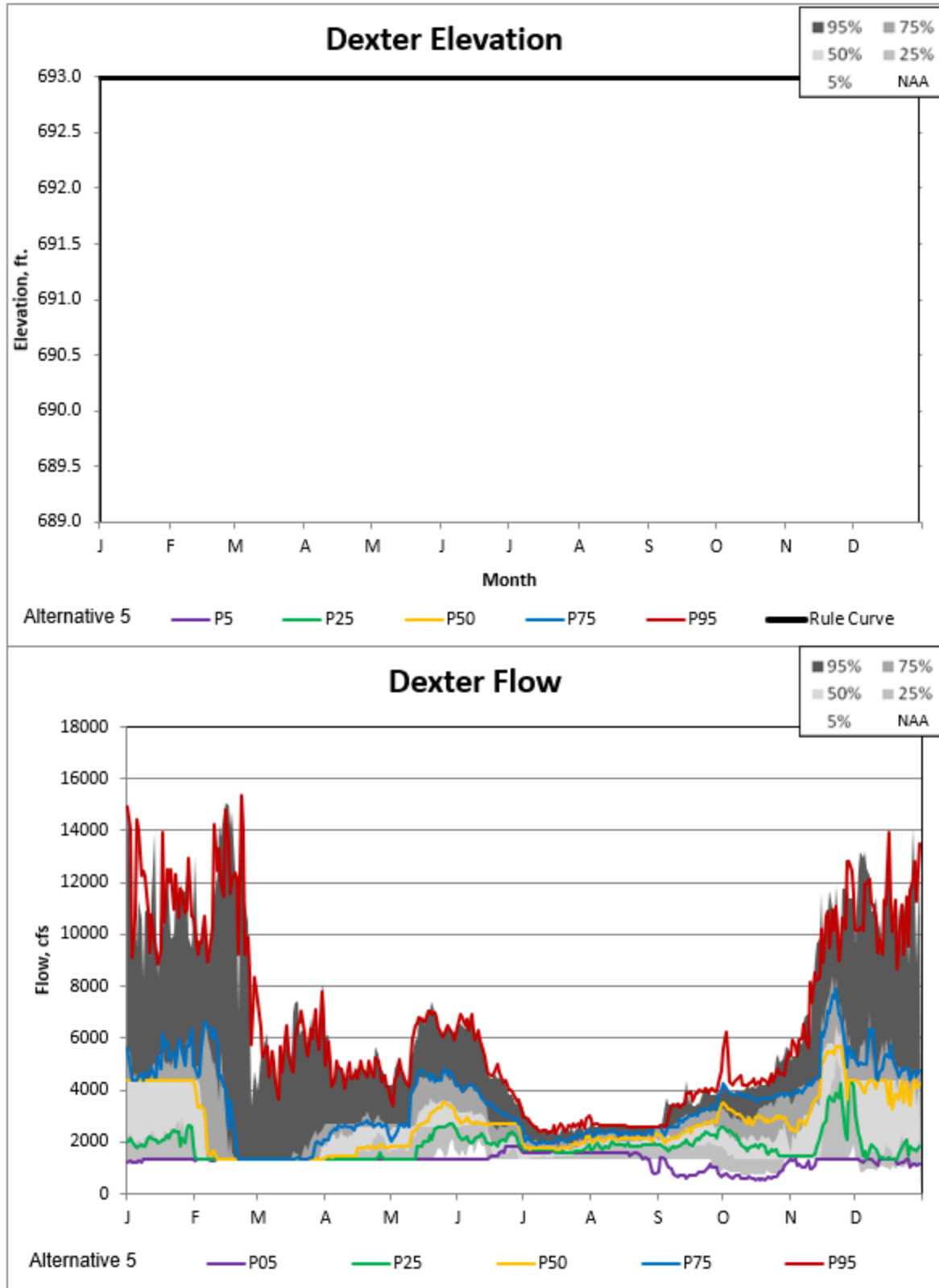

Figure 5-145. Dexter Alternative 5 Non-exceedance Plot.

Willamette Valley System Operations and Maintenance
Environmental Impact Statement

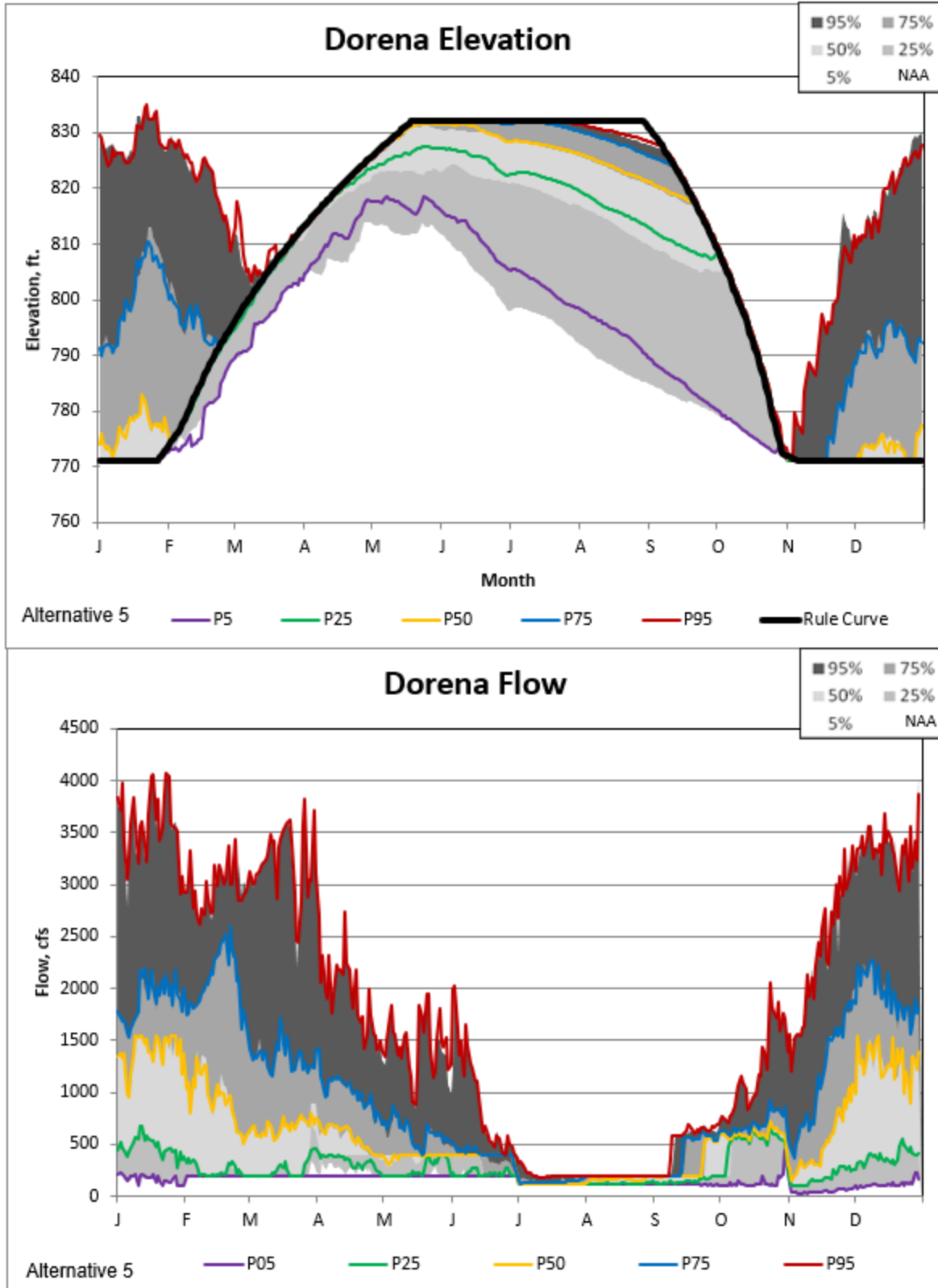

Figure 5-146. Dorena Alternative 5 Non-exceedance Plot.

Willamette Valley System Operations and Maintenance
Environmental Impact Statement

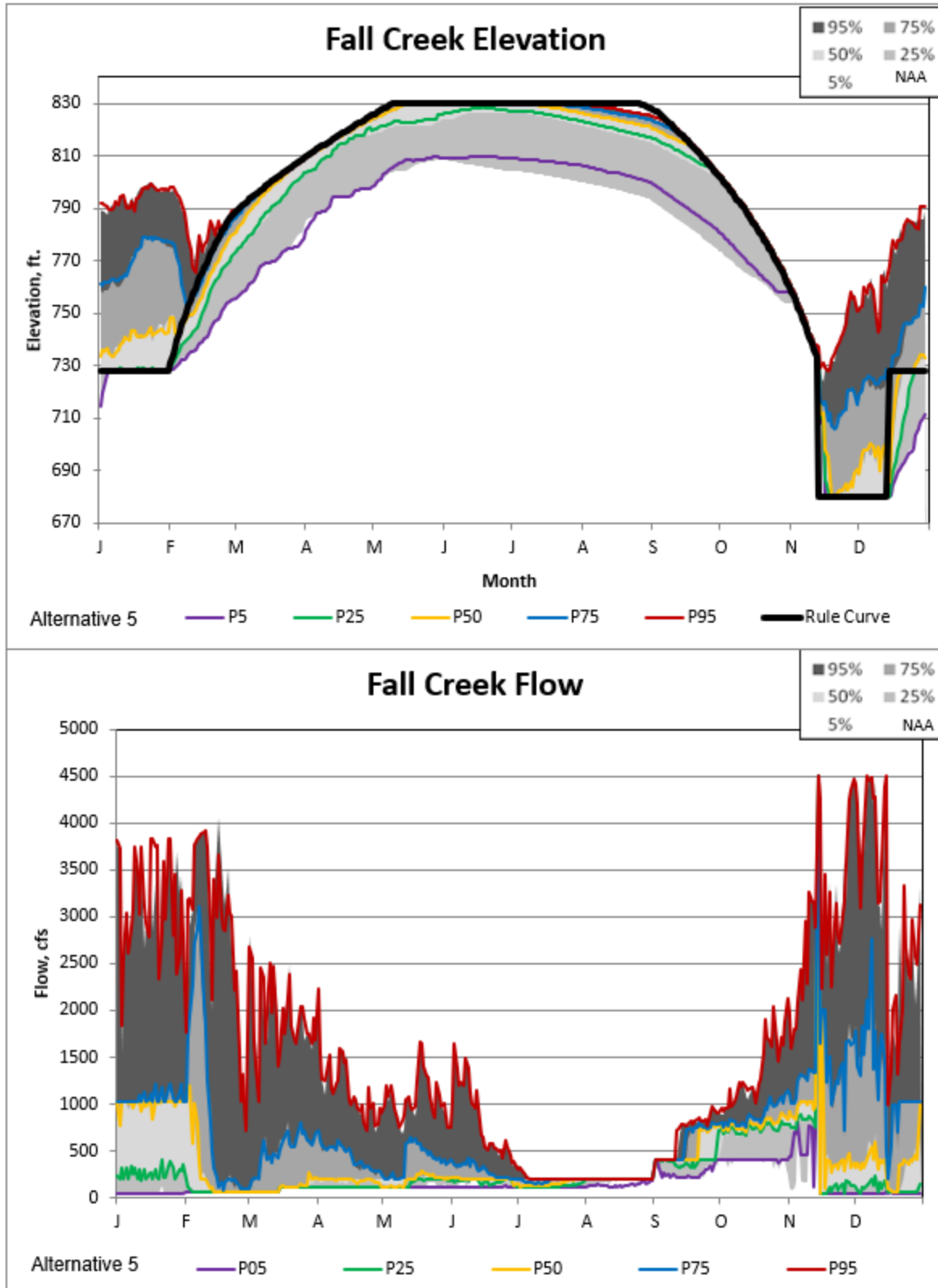

Figure 5-147. Fall Creek Alternative 5 Non-exceedance Plot.

Willamette Valley System Operations and Maintenance
Environmental Impact Statement

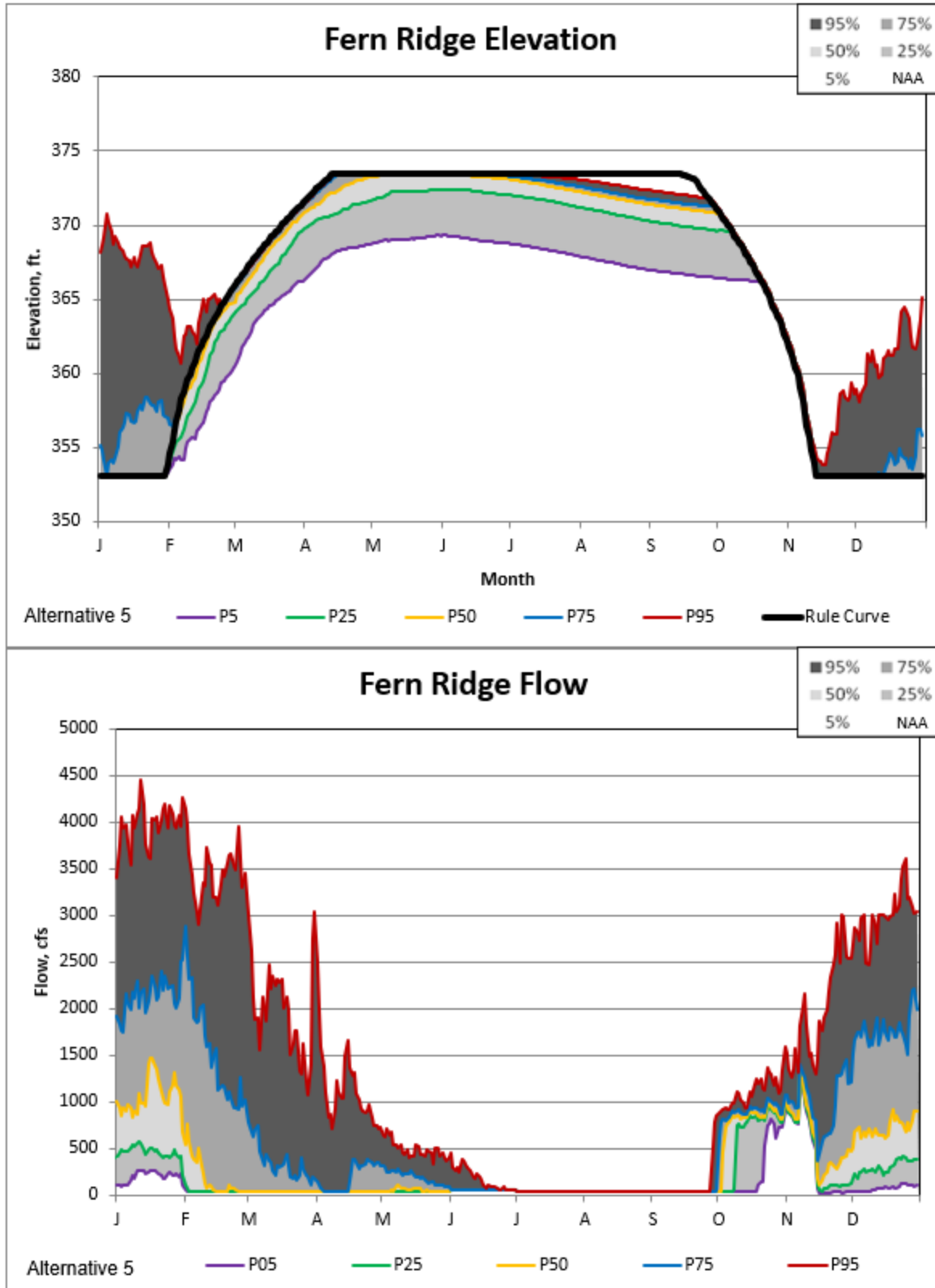

Figure 5-148. Fern Ridge Alternative 5 Non-exceedance Plot.

Willamette Valley System Operations and Maintenance
Environmental Impact Statement

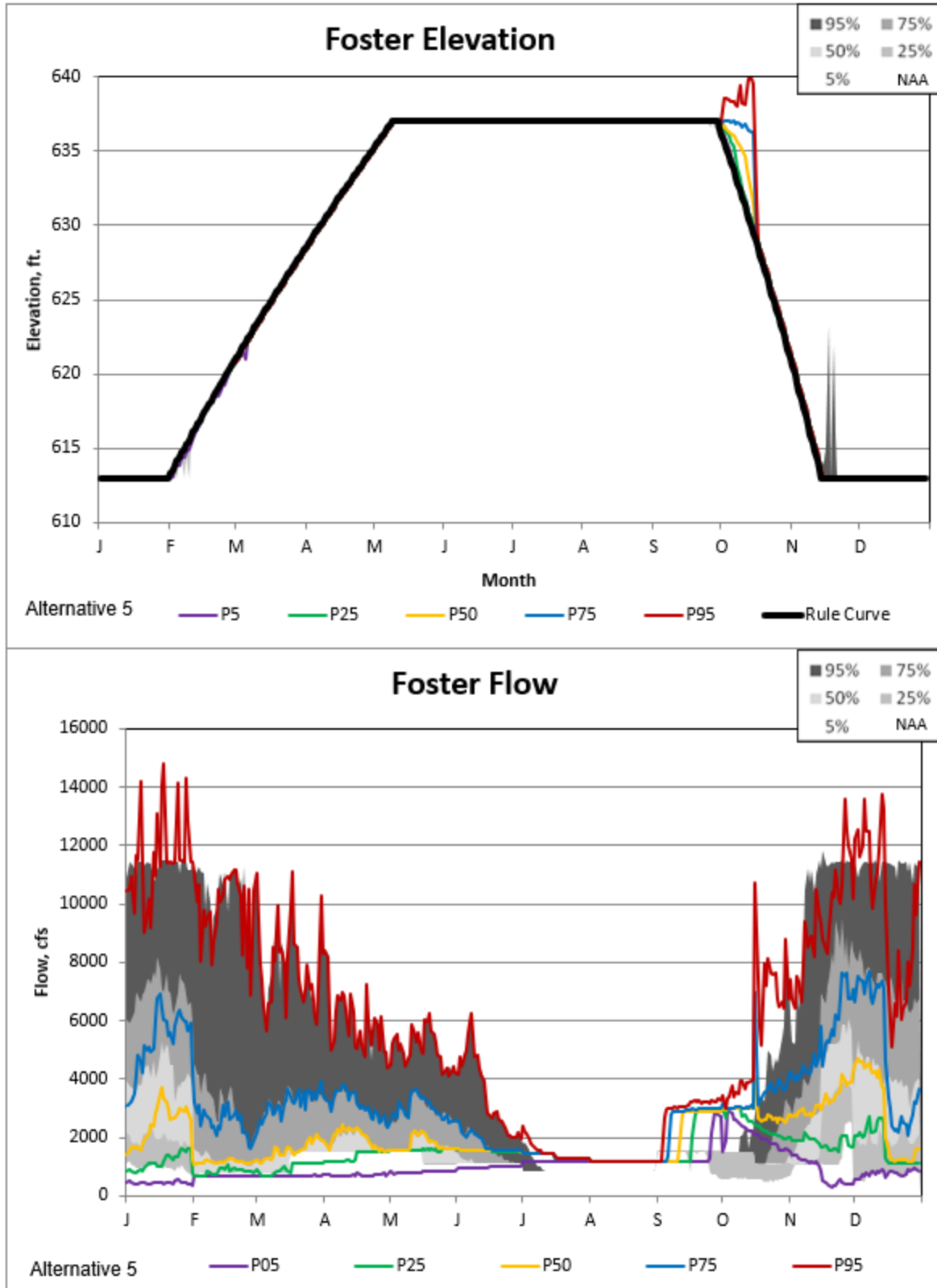

Figure 5-149. Foster Alternative 5 Non-exceedance Plot.

Willamette Valley System Operations and Maintenance
Environmental Impact Statement

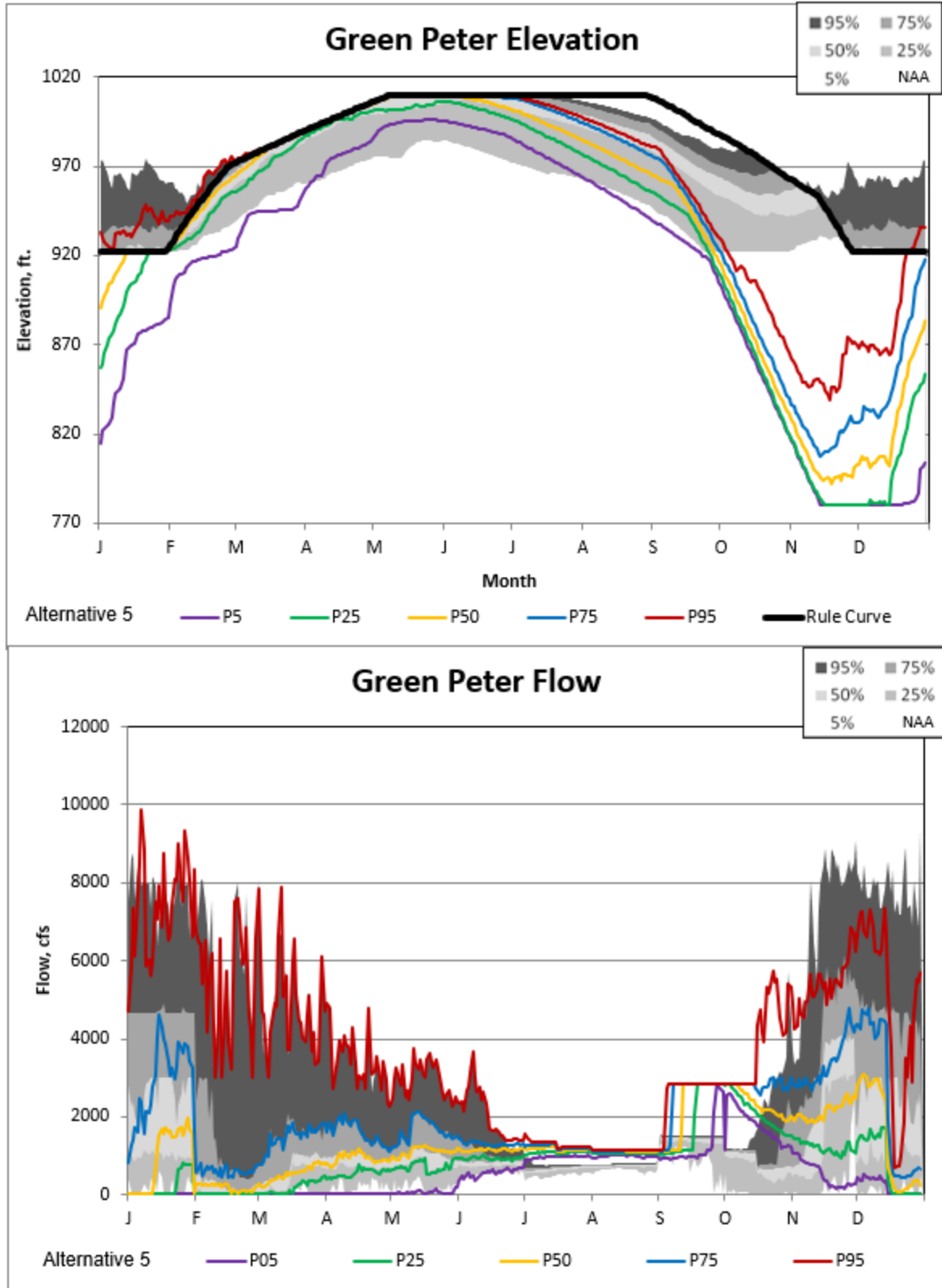

Figure 5-150. Green Peter Alternative 5 Non-exceedance Plot.

Willamette Valley System Operations and Maintenance
Environmental Impact Statement

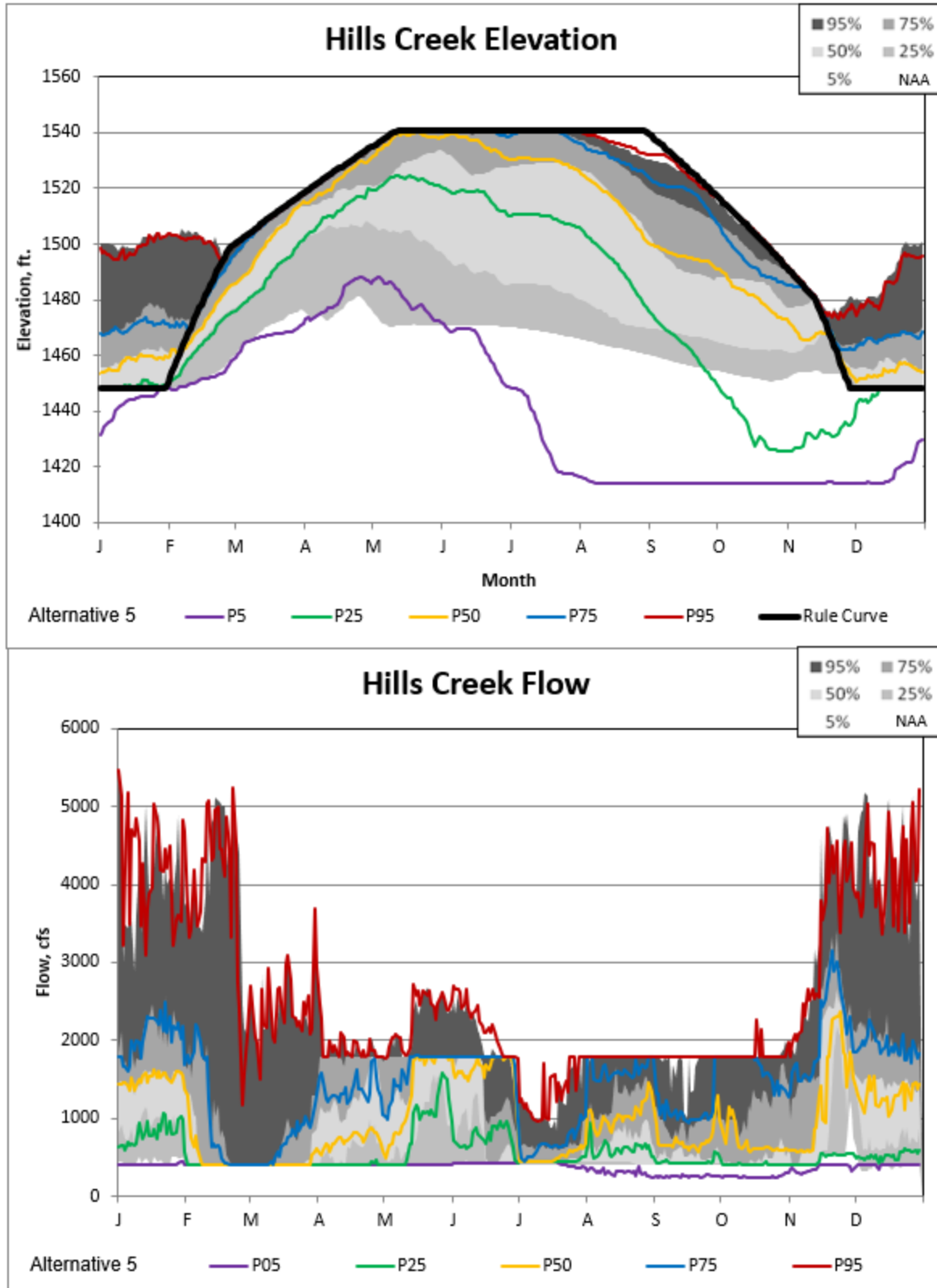

Figure 5-151. Hills Creek Alternative 5 Non-exceedance Plot.

Willamette Valley System Operations and Maintenance
Environmental Impact Statement

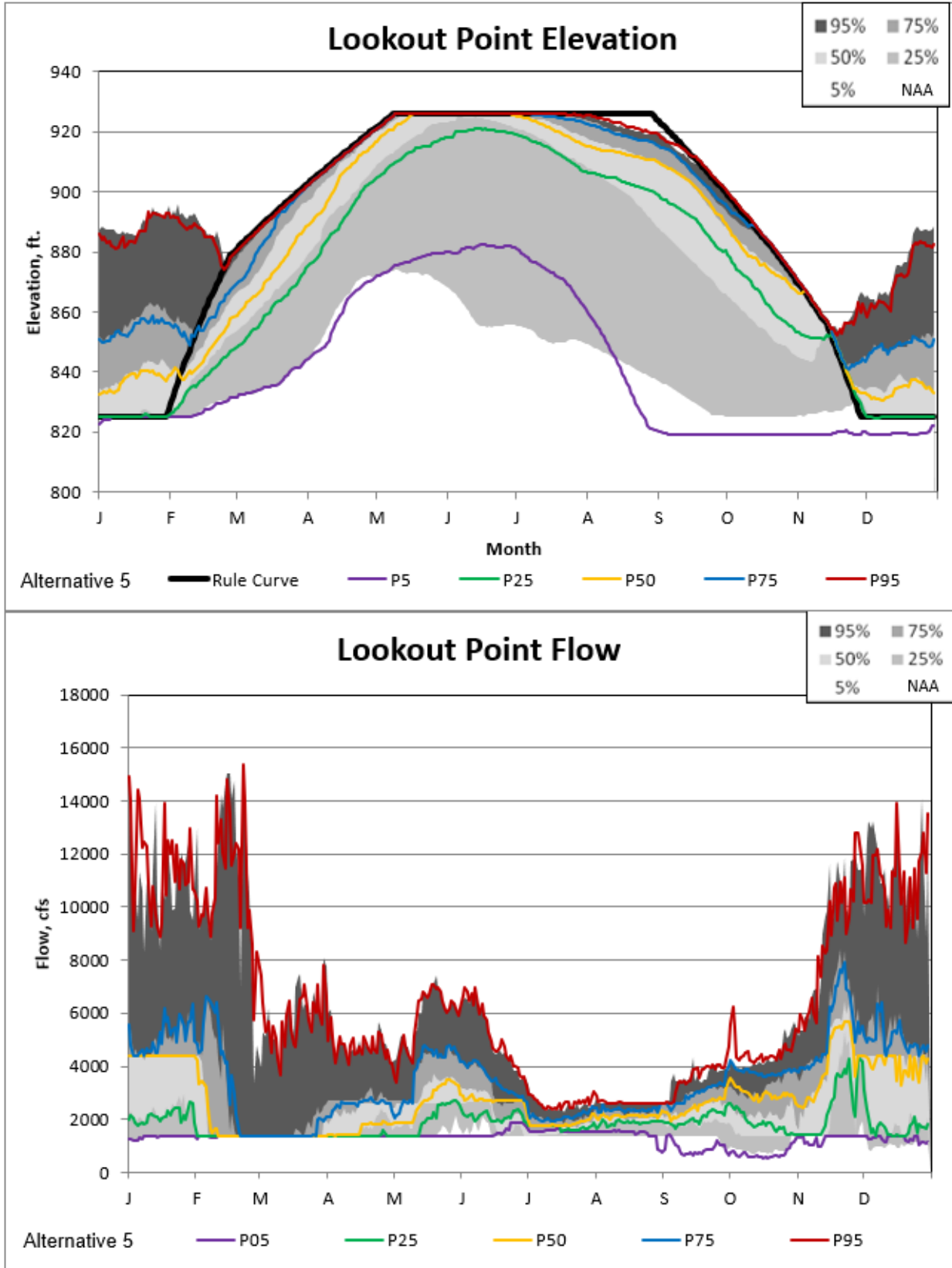

Figure 5-152. Lookout Point Alternative 5 Non-exceedance Plot.

*Willamette Valley System Operations and Maintenance
Environmental Impact Statement*

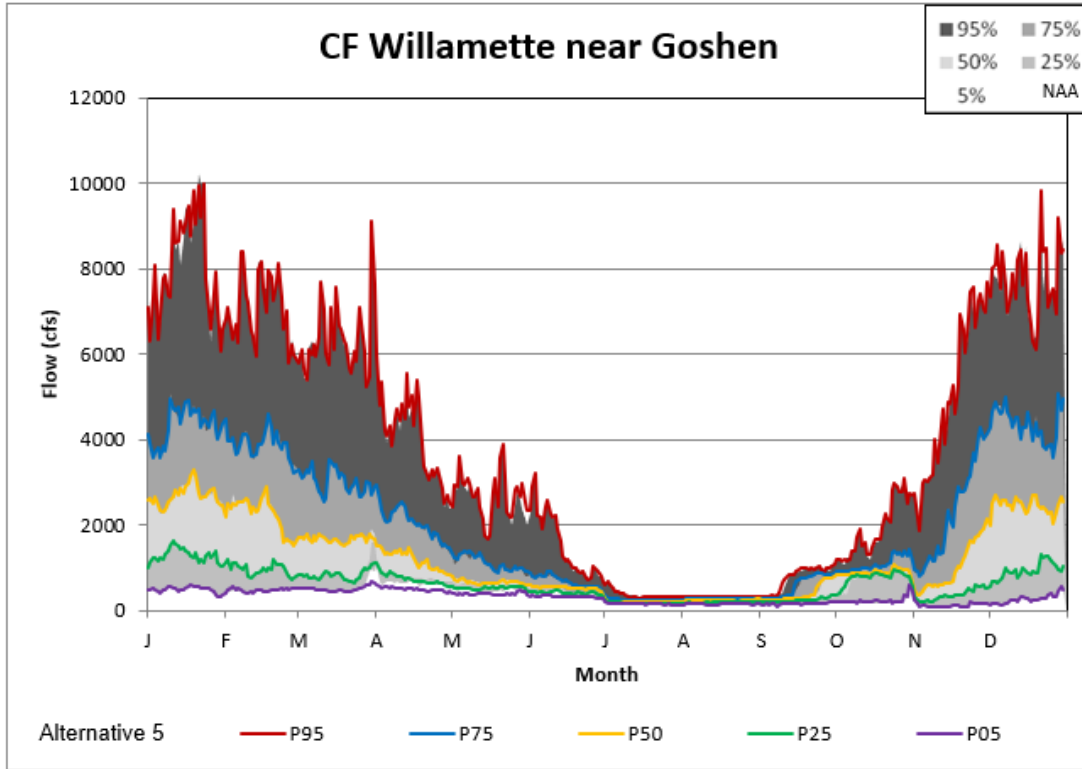

Figure 5-153. Goshen Alternative 5 Non-exceedance Plot.

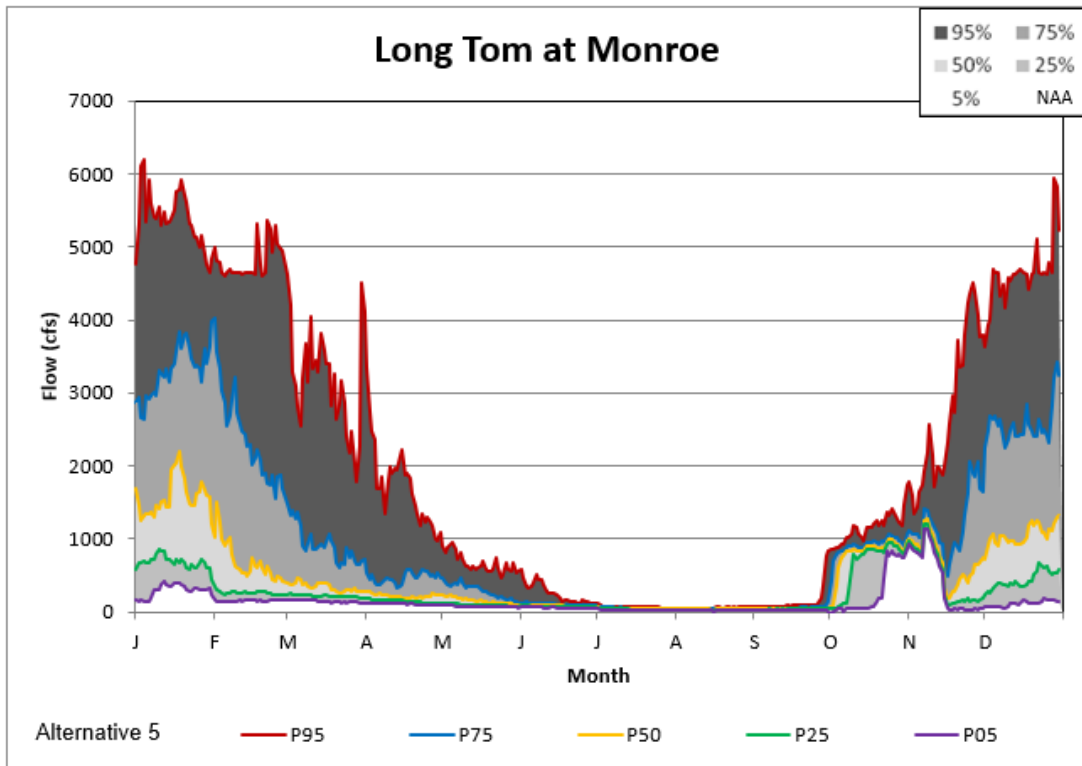

Figure 5-154. Monroe Alternative 5 Non-exceedance Plot.

Willamette Valley System Operations and Maintenance
Environmental Impact Statement

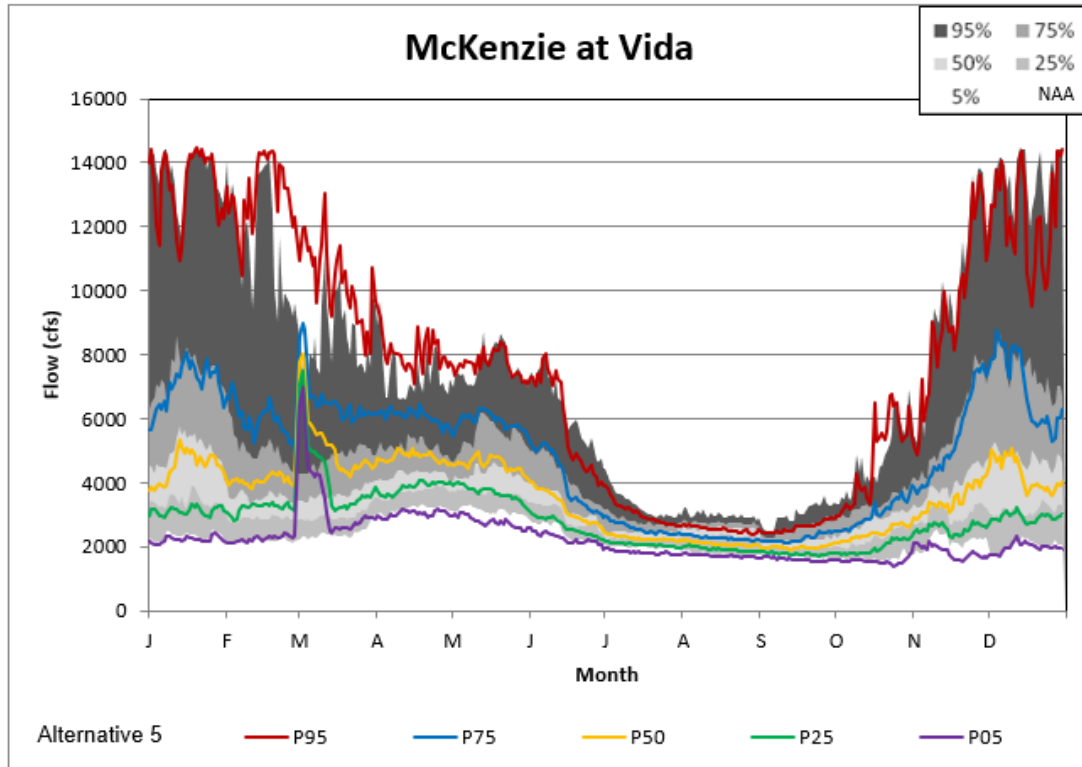

Figure 5-155. Vida Alternative 5 Non-exceedance Plot.

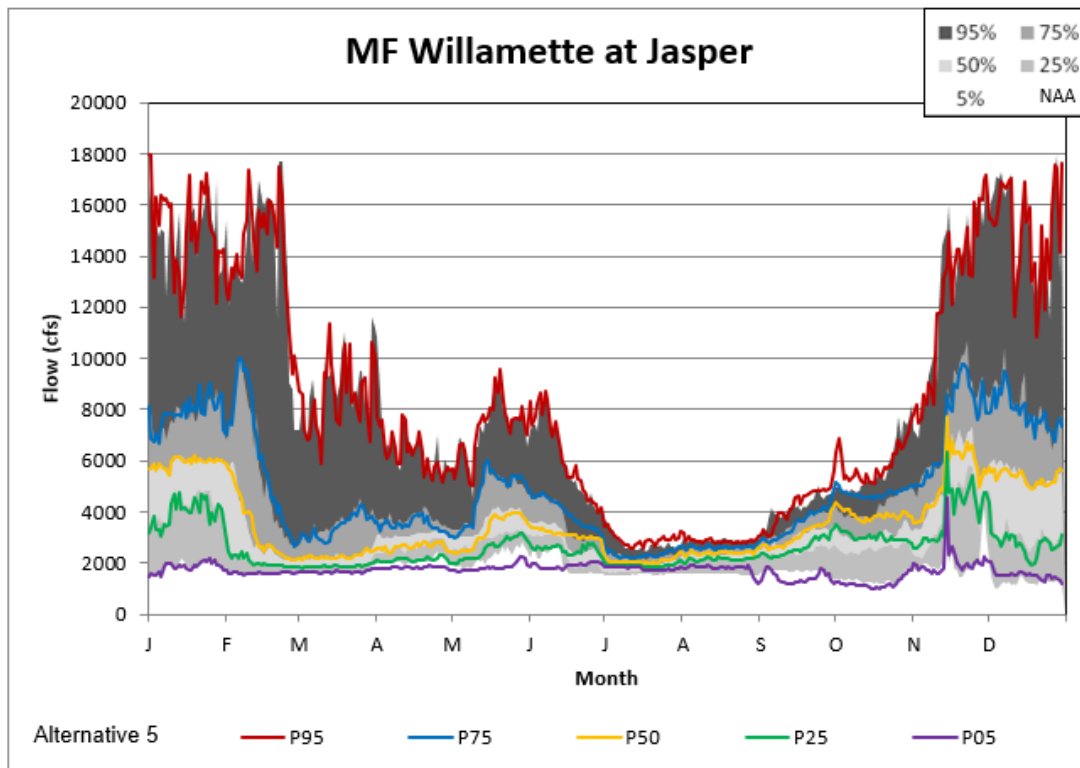

Figure 5-156. Jasper Alternative 5 Non-exceedance Plot.

Willamette Valley System Operations and Maintenance
Environmental Impact Statement

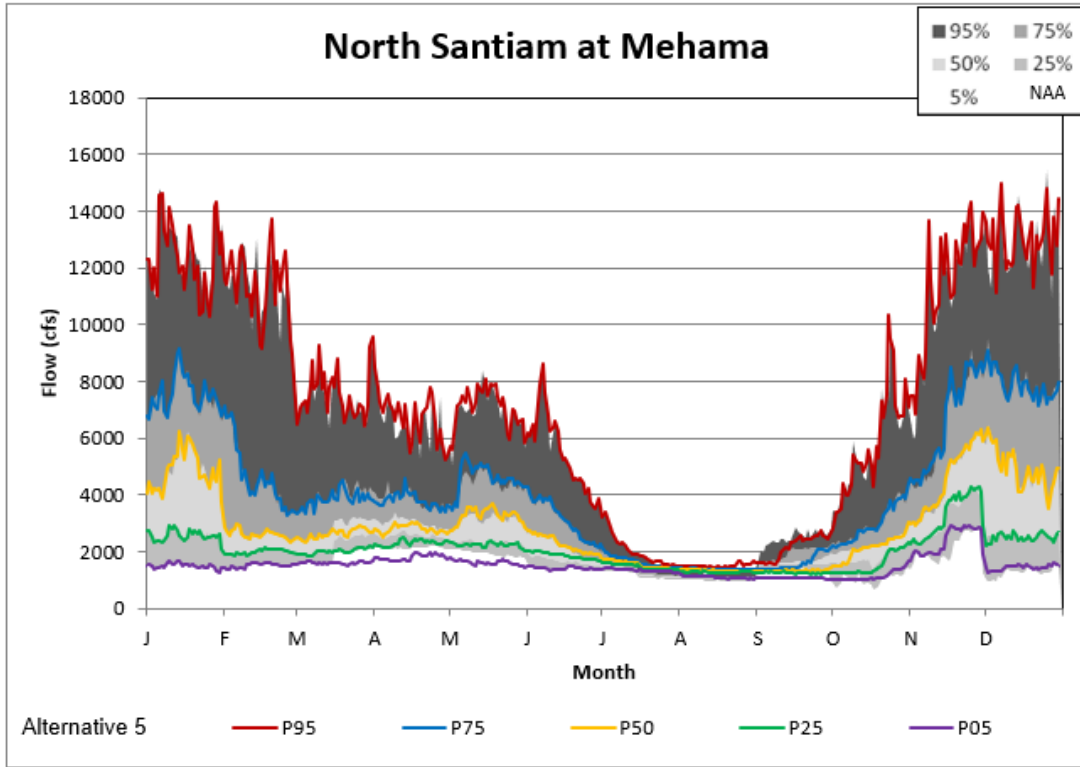

Figure 5-157. Mehama Alternative 5 Non-exceedance Plot.

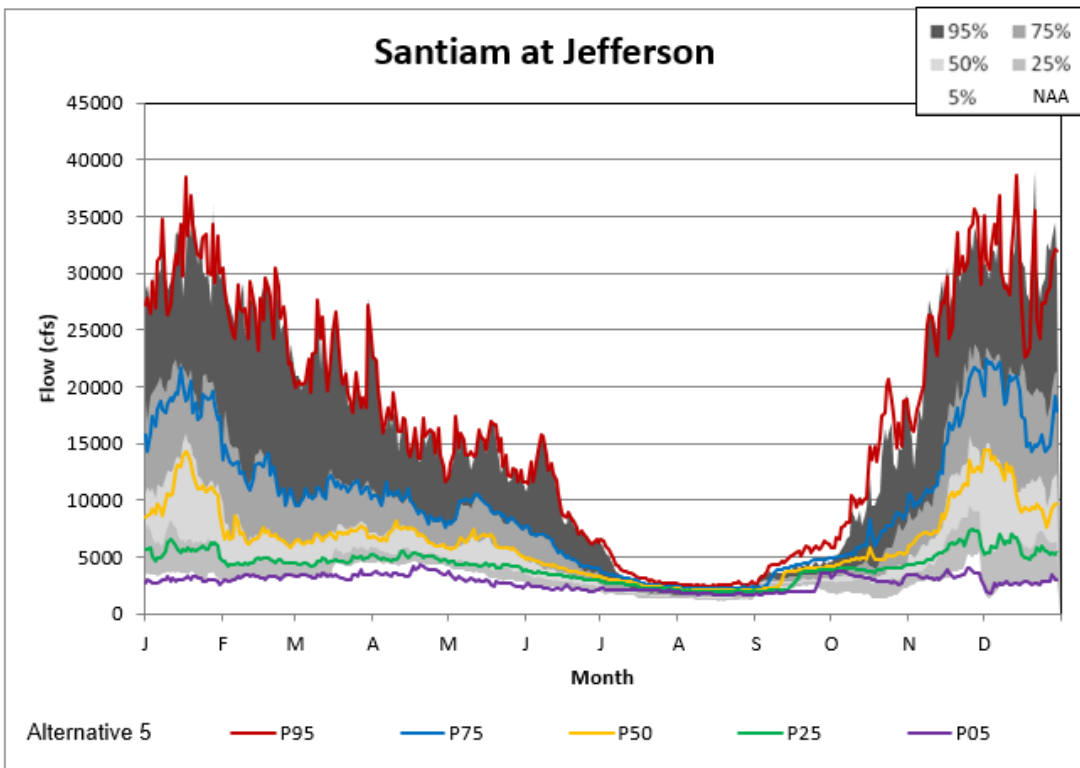

Figure 5-158. Jefferson Alternative 5 Non-exceedance Plot.

Willamette Valley System Operations and Maintenance
Environmental Impact Statement

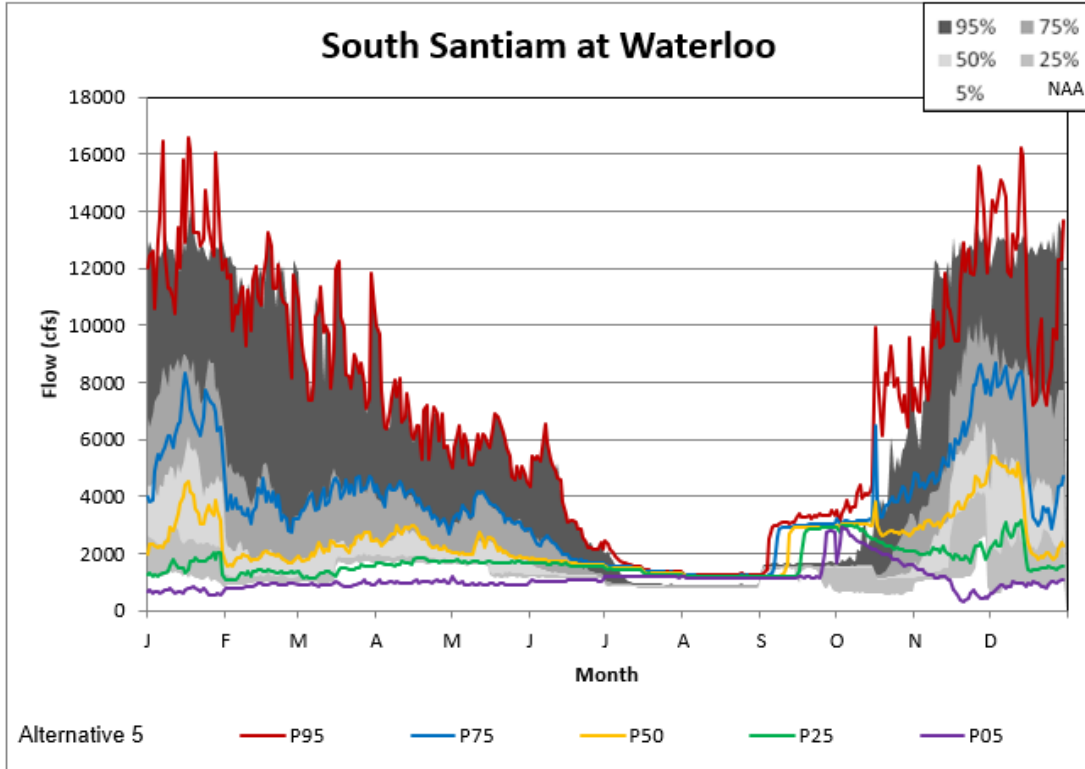

Figure 5-159. Waterloo Alternative 5 Non-exceedance Plot.

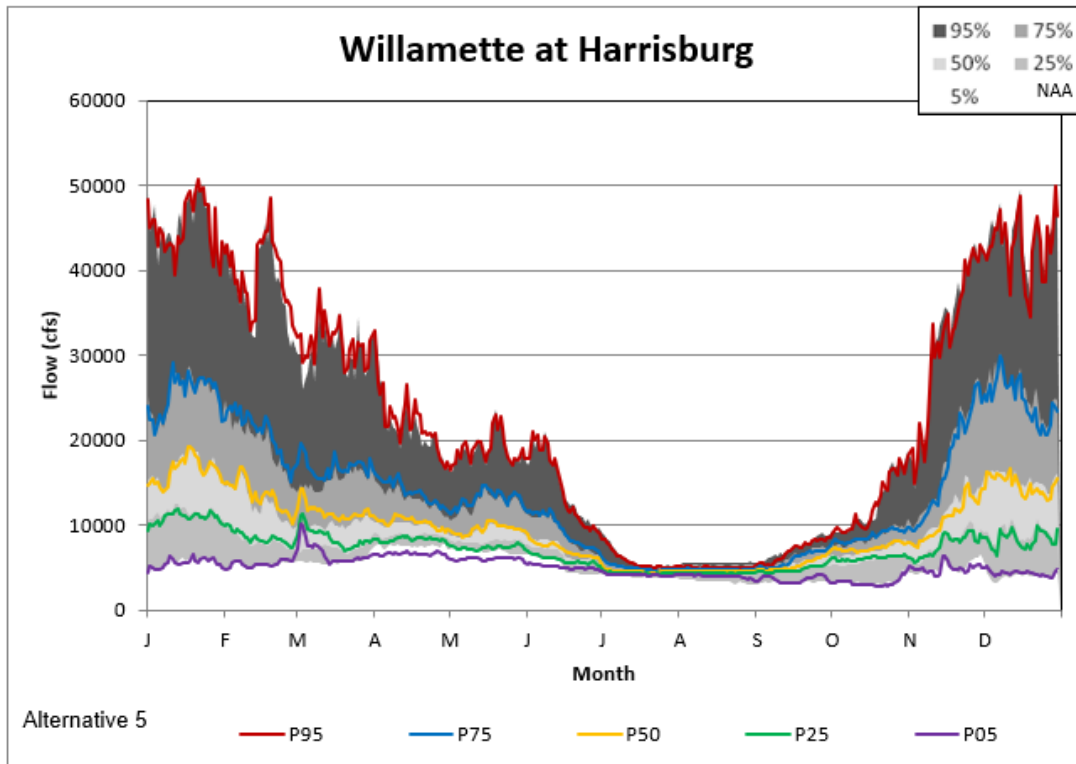

Figure 5-160. Harrisburg Alternative 5 Non-exceedance Plot.

Willamette Valley System Operations and Maintenance
Environmental Impact Statement

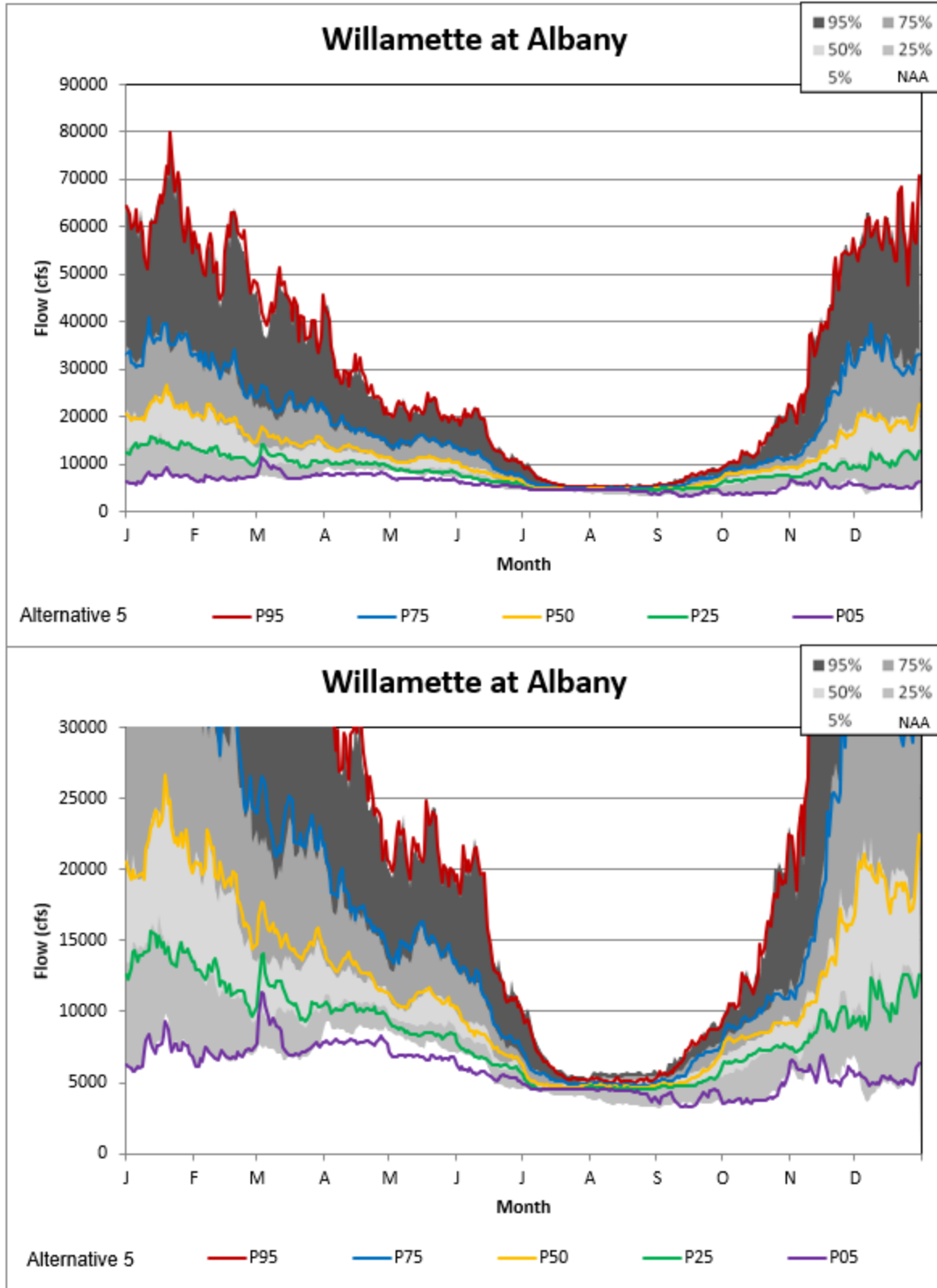

Figure 5-161. Albany Alternative 5 Non-exceedance Plot.

Willamette Valley System Operations and Maintenance
Environmental Impact Statement

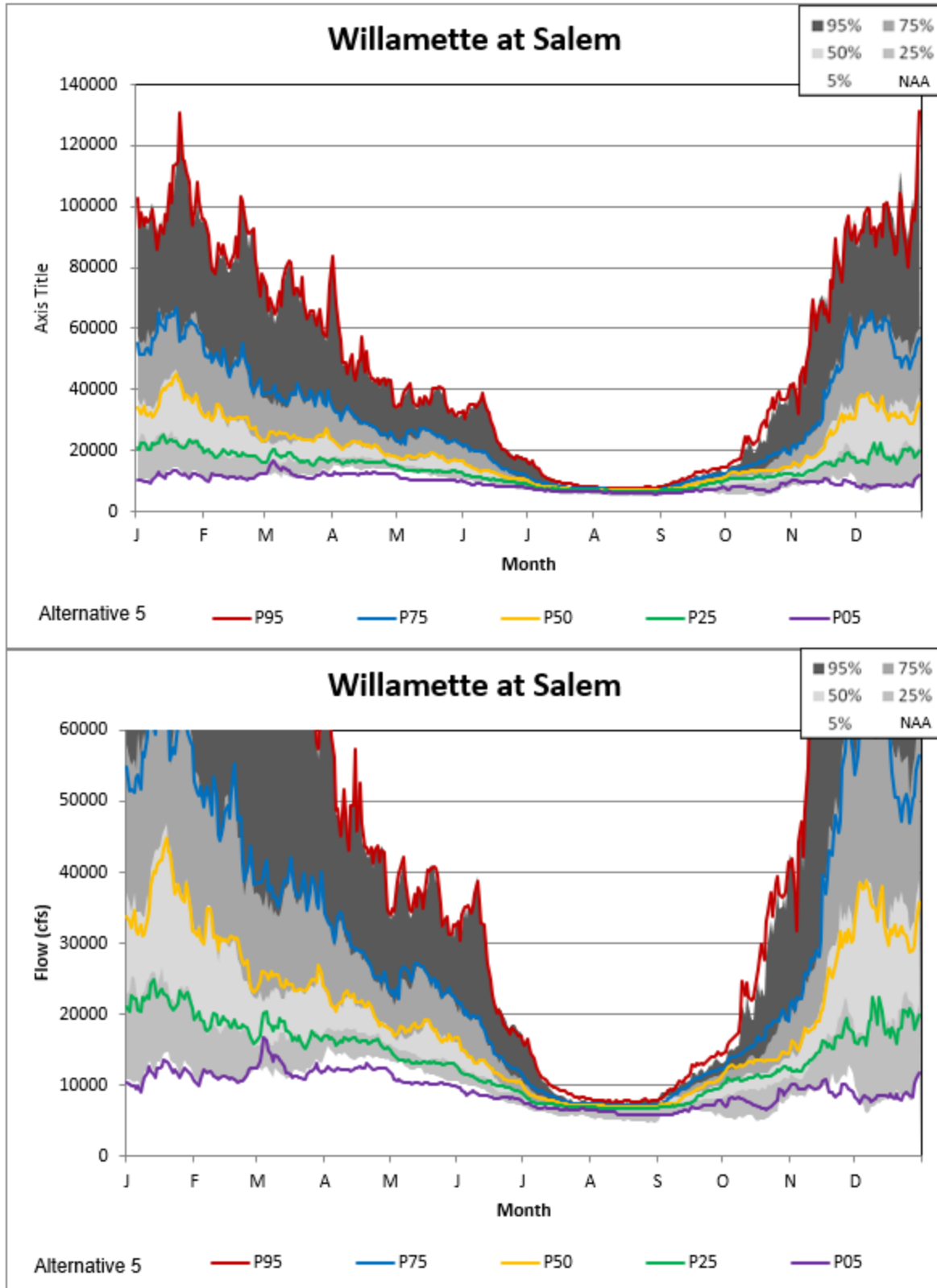

Figure 5-162. Salem Alternative 5 Non-exceedance Plot.

5.8 Alternative 6

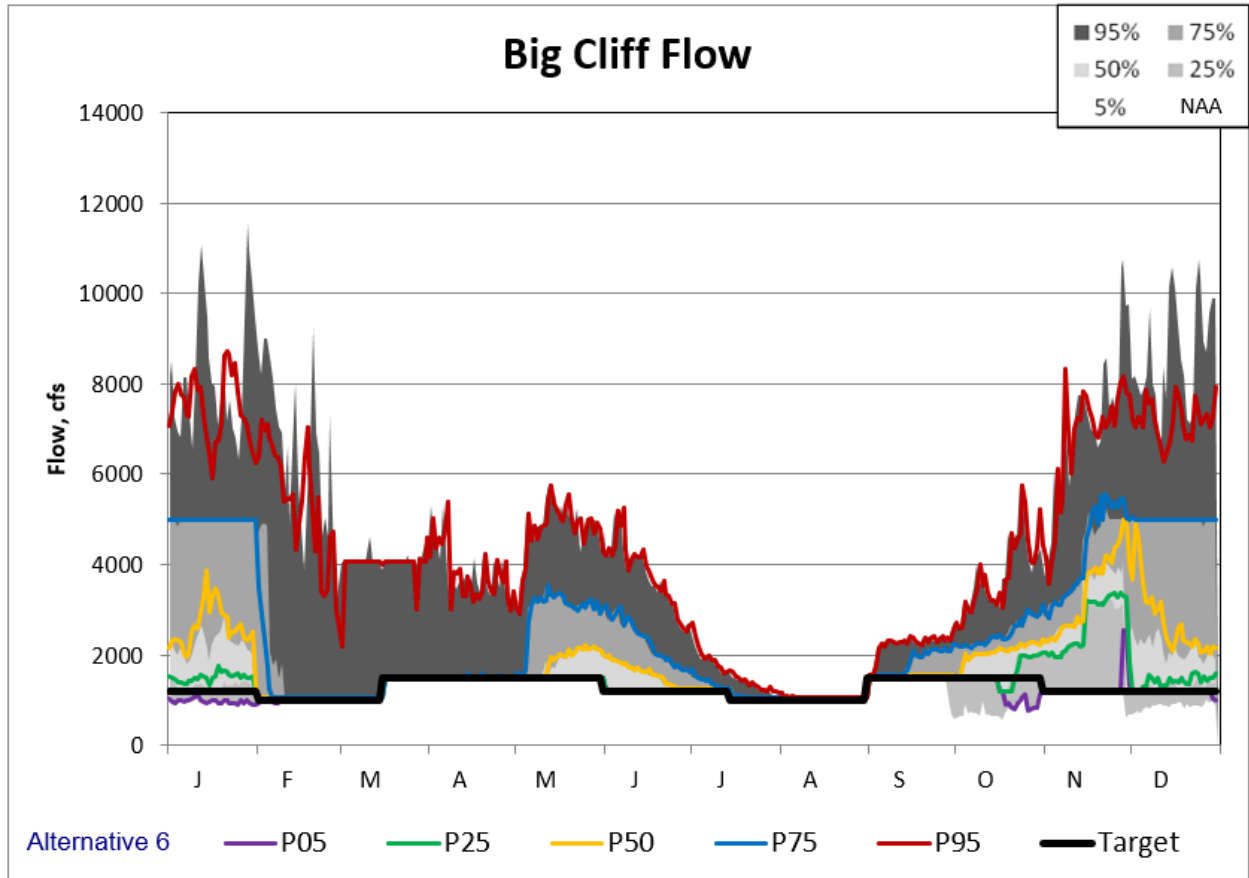

Figure 5-163. Big Cliff Alternative 6 Non-exceedance Plot.

Willamette Valley System Operations and Maintenance
Environmental Impact Statement

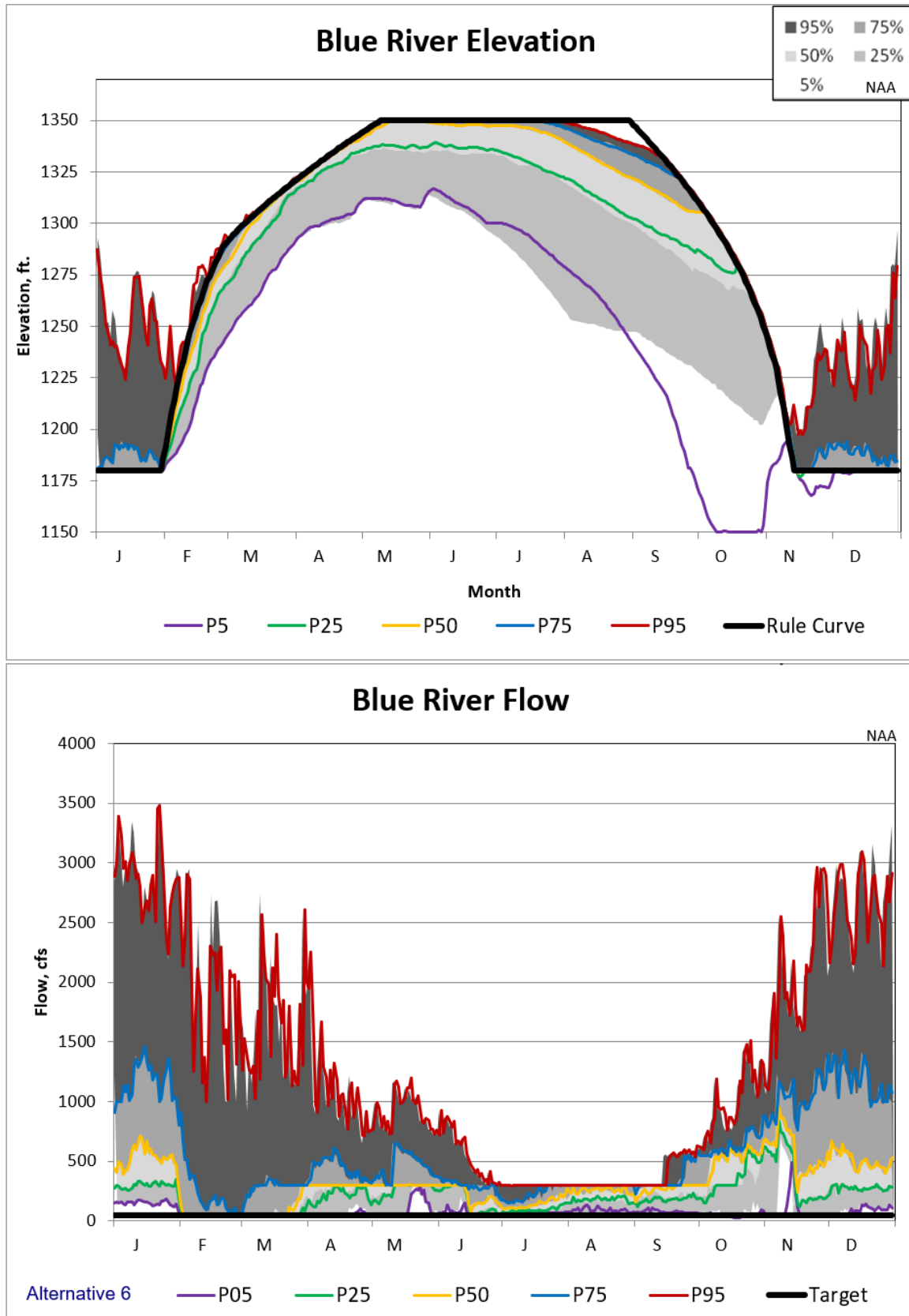

Figure 5-164. Blue River Alternative 6 Non-exceedance Plot.

Willamette Valley System Operations and Maintenance
Environmental Impact Statement

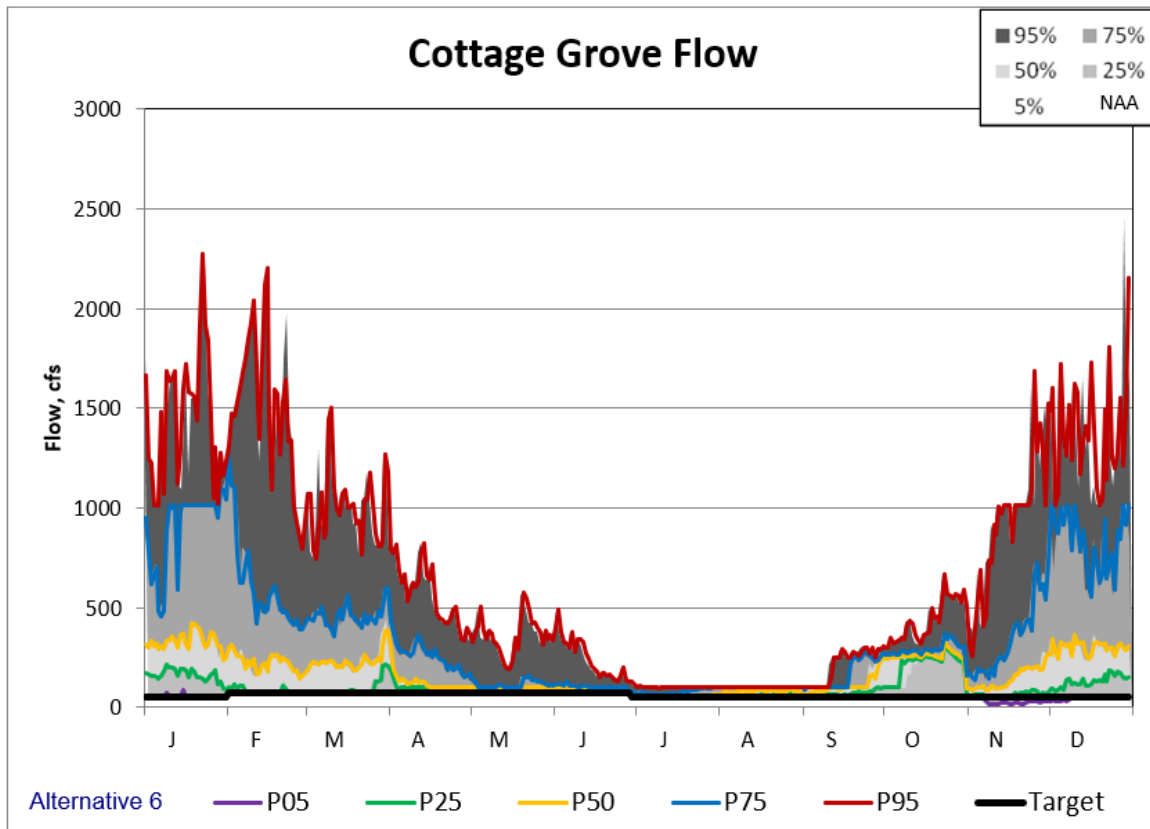
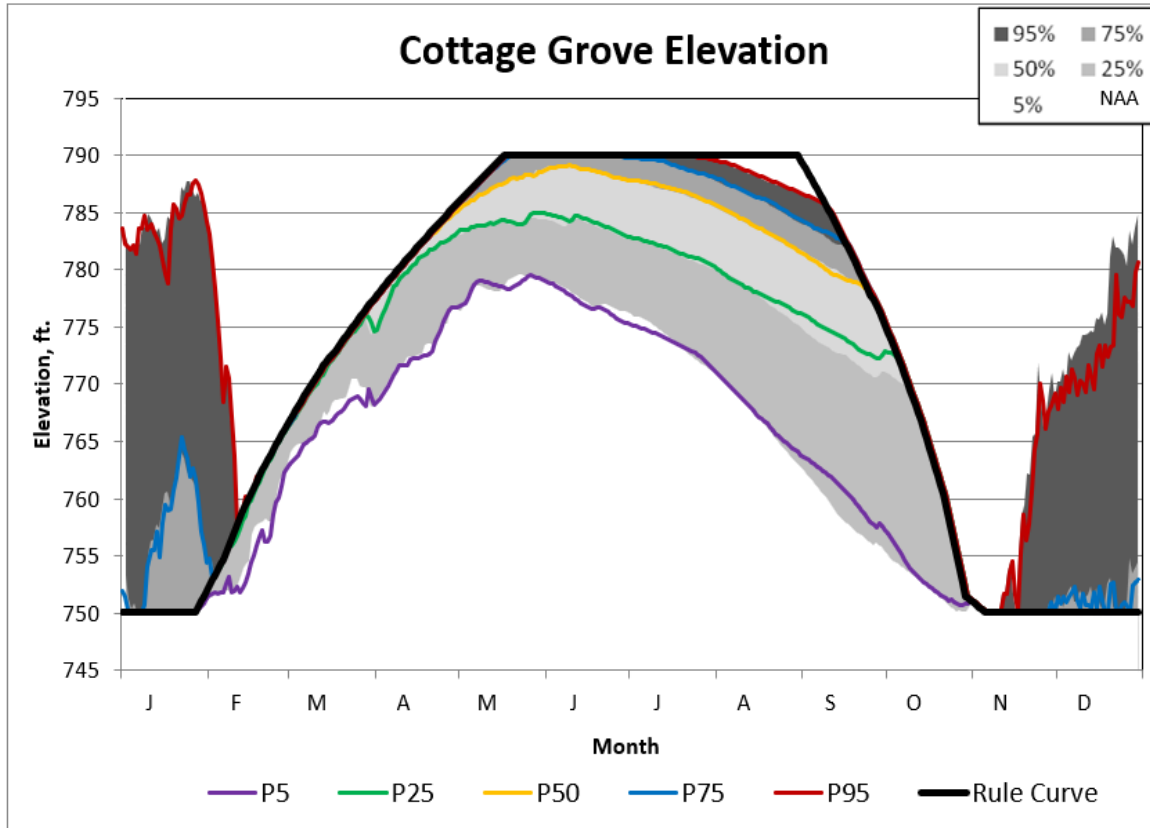

Figure 5-165. Cottage Grove Alternative 6 Non-exceedance Plot.

Willamette Valley System Operations and Maintenance
Environmental Impact Statement

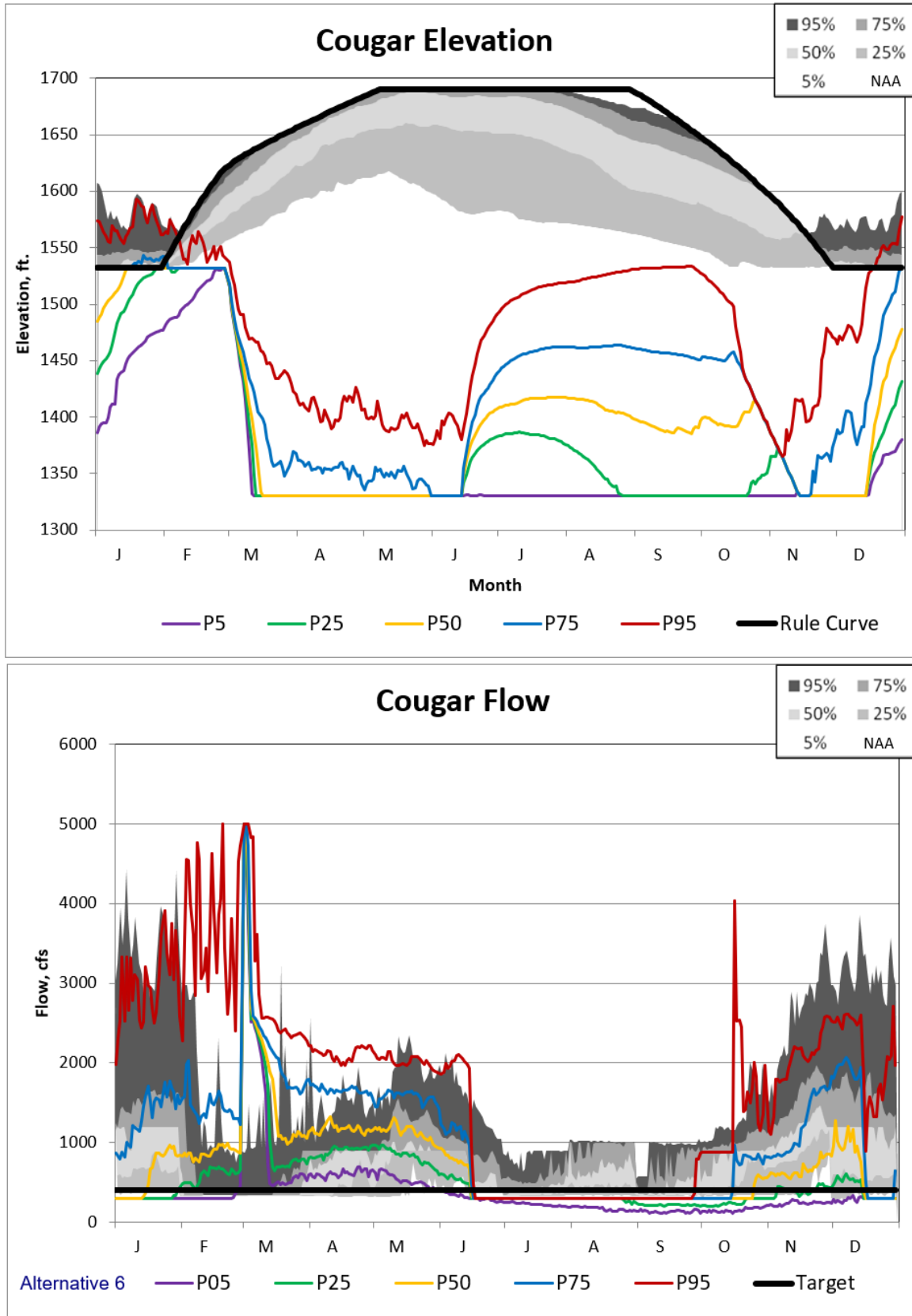

Figure 5-166. Cougar Alternative 6 Non-exceedance Plot.

*Willamette Valley System Operations and Maintenance
Environmental Impact Statement*

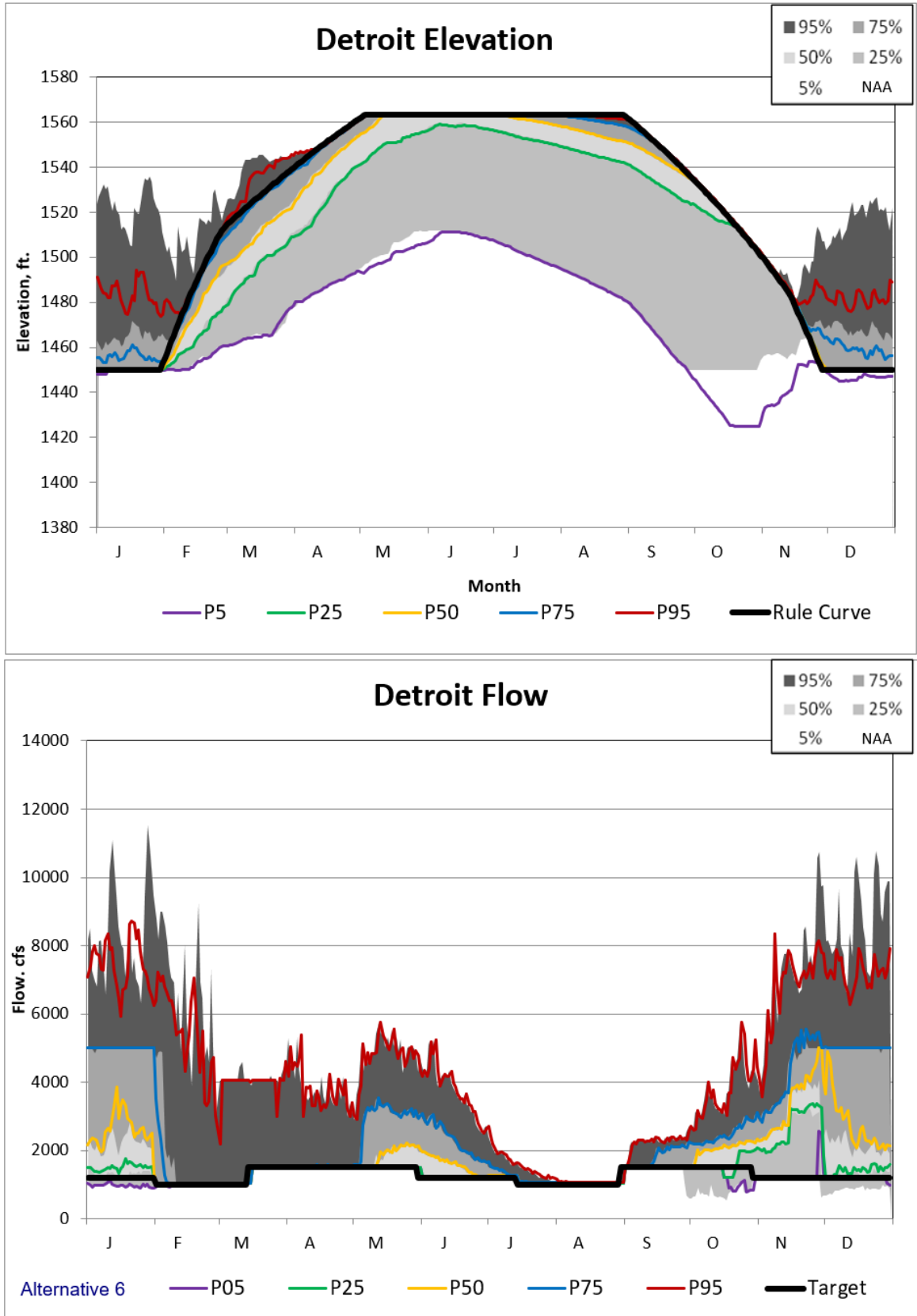

Figure 5-167. Detroit Alternative 6 Non-exceedance Plot.

Willamette Valley System Operations and Maintenance
Environmental Impact Statement

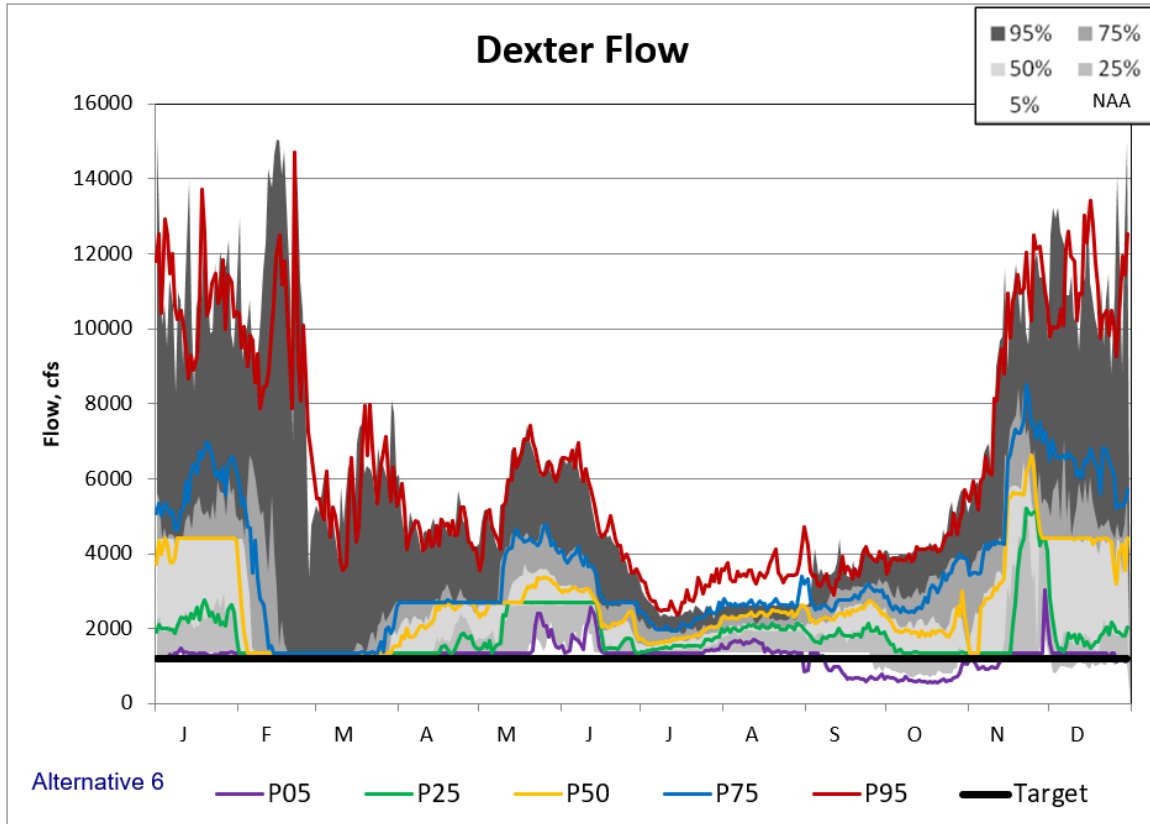

Figure 5-168. Dexter Alternative 6 Non-exceedance Plot.

*Willamette Valley System Operations and Maintenance
Environmental Impact Statement*

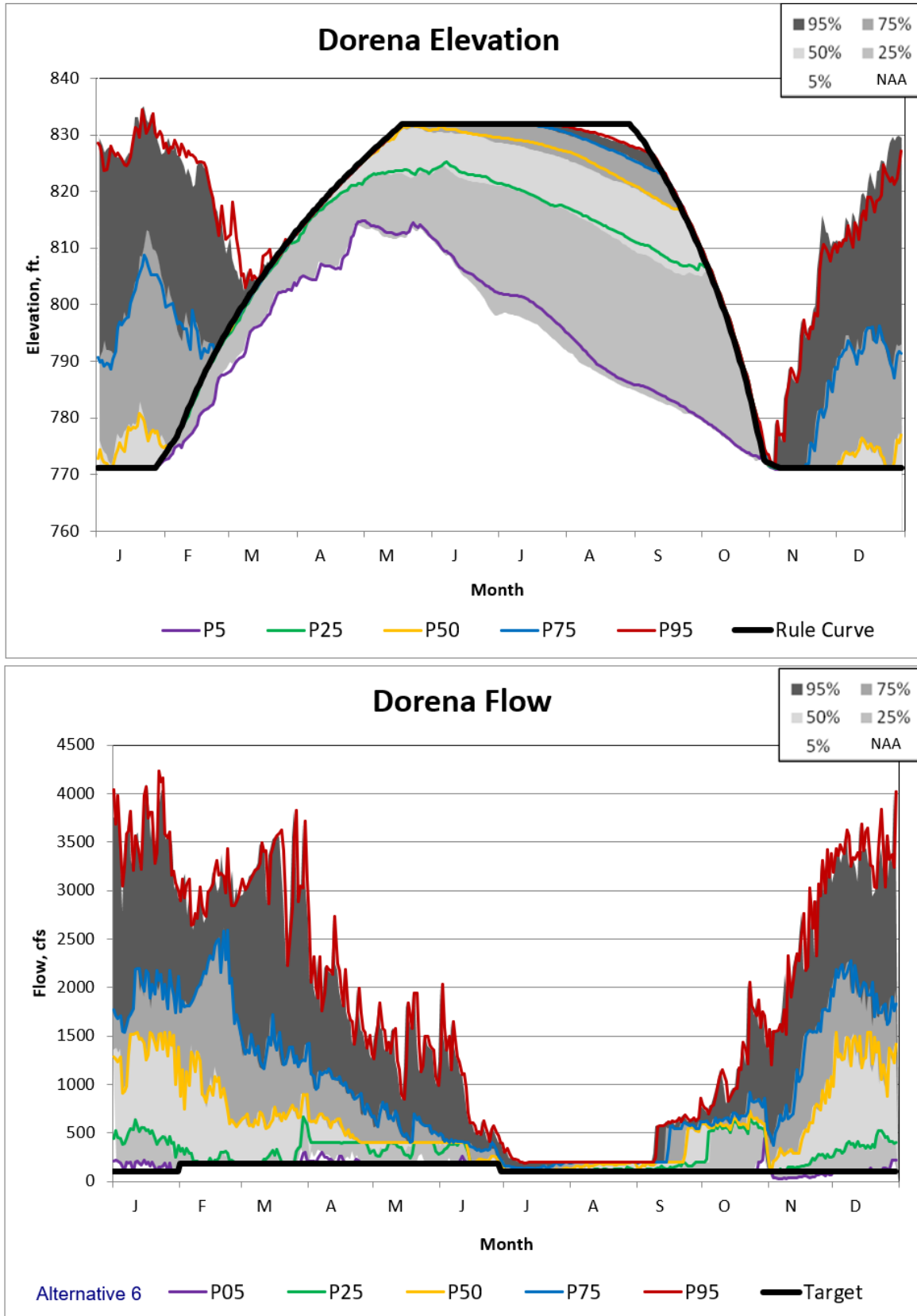

Figure 5-169. Dorena Alternative 6 Non-exceedance Plot.

Willamette Valley System Operations and Maintenance
Environmental Impact Statement

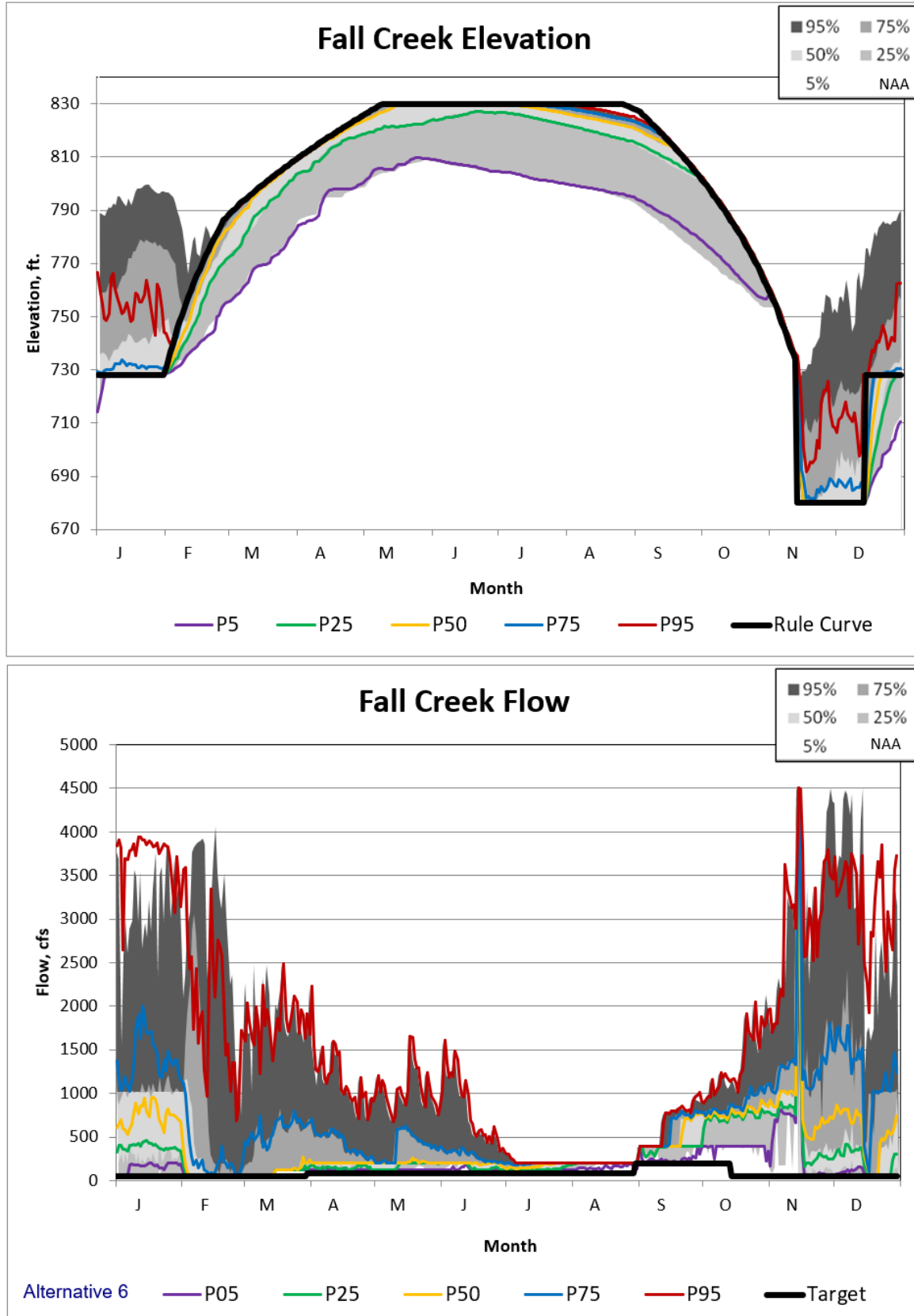

Figure 5-170. Fall Creek Alternative 6 Non-exceedance Plot.

Willamette Valley System Operations and Maintenance
Environmental Impact Statement

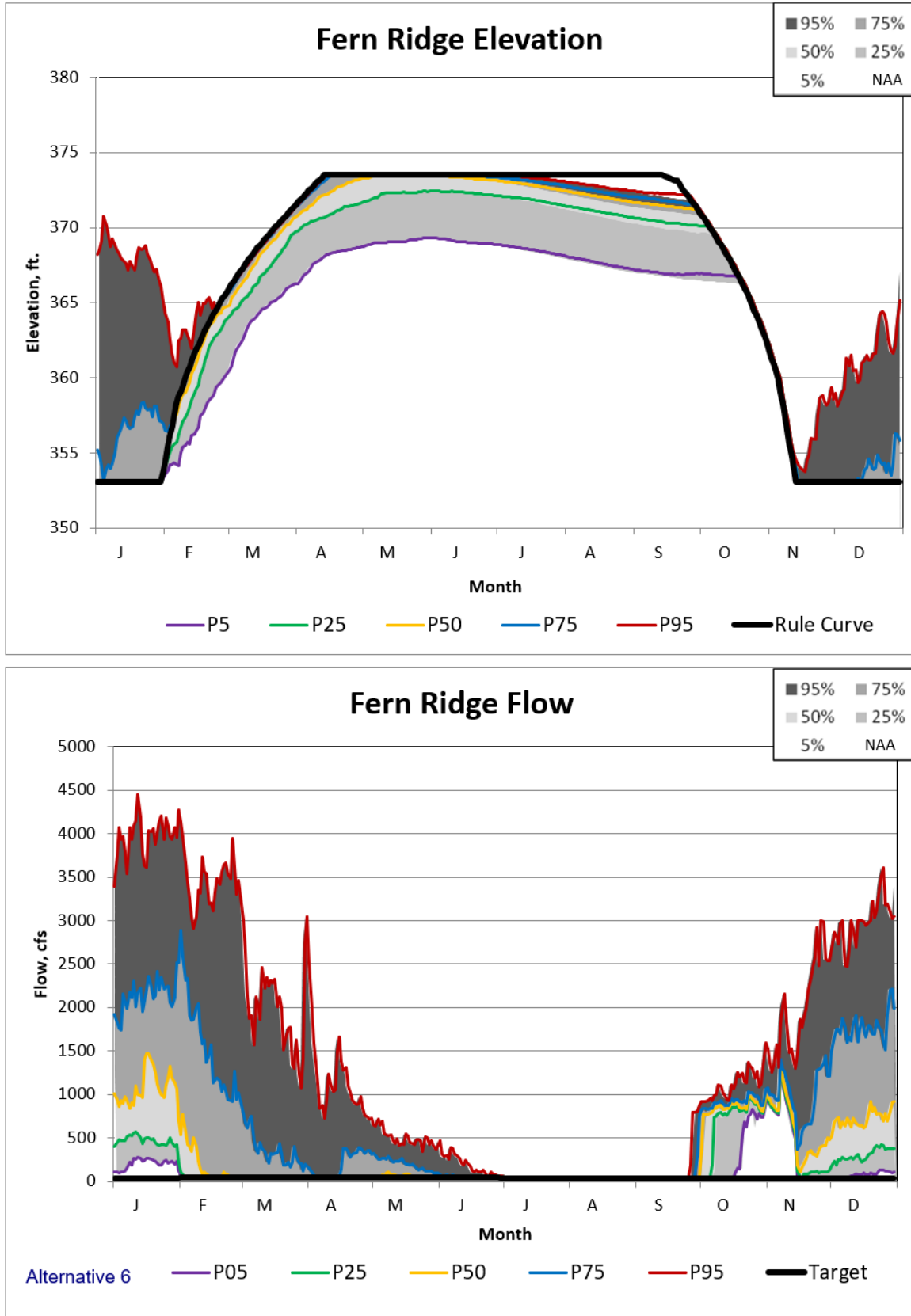

Figure 5-171. Fern Ridge Alternative 6 Non-exceedance Plot.

Willamette Valley System Operations and Maintenance
Environmental Impact Statement

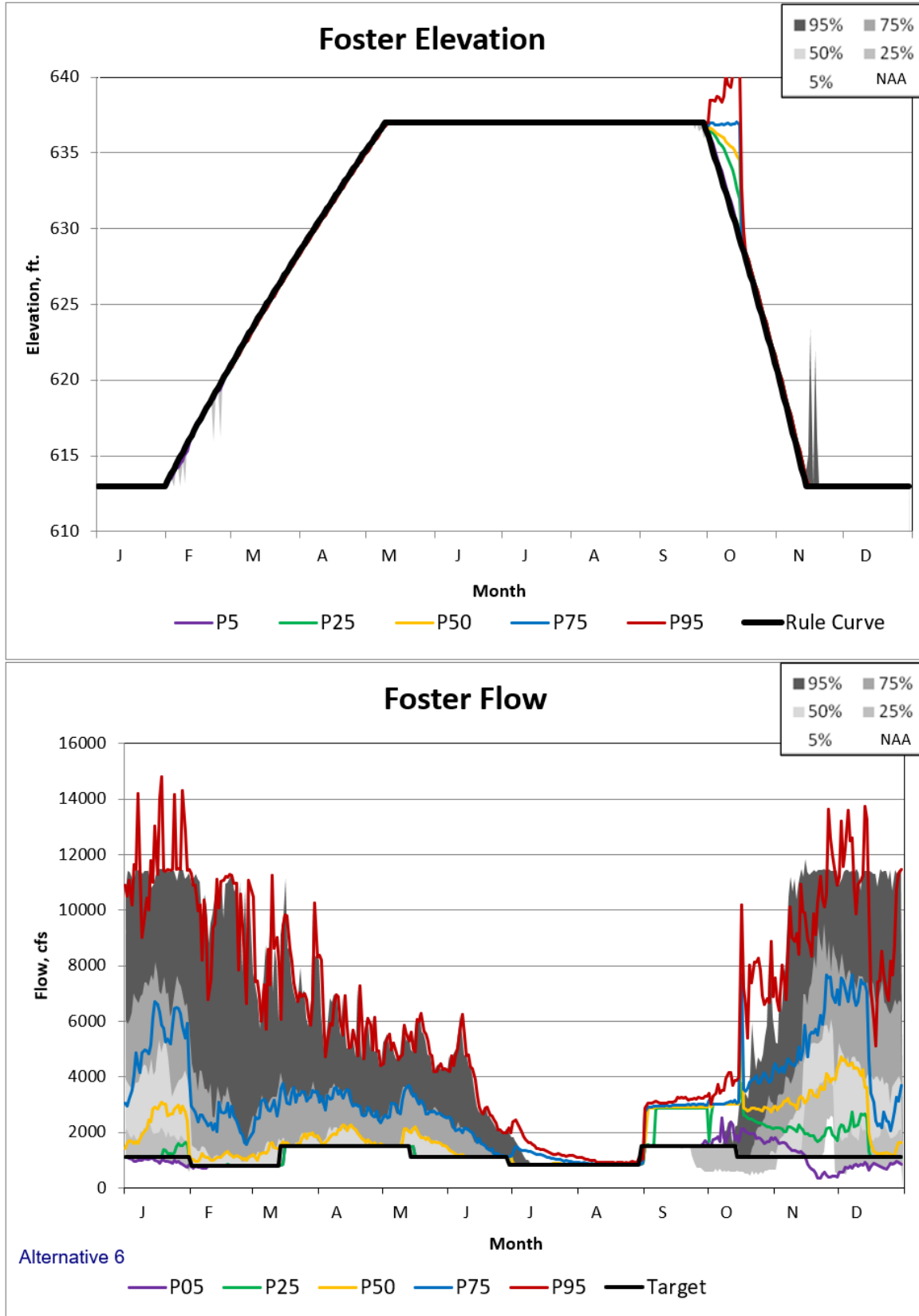

Figure 5-172. Foster Alternative 6 Non-exceedance Plot.

Willamette Valley System Operations and Maintenance
Environmental Impact Statement

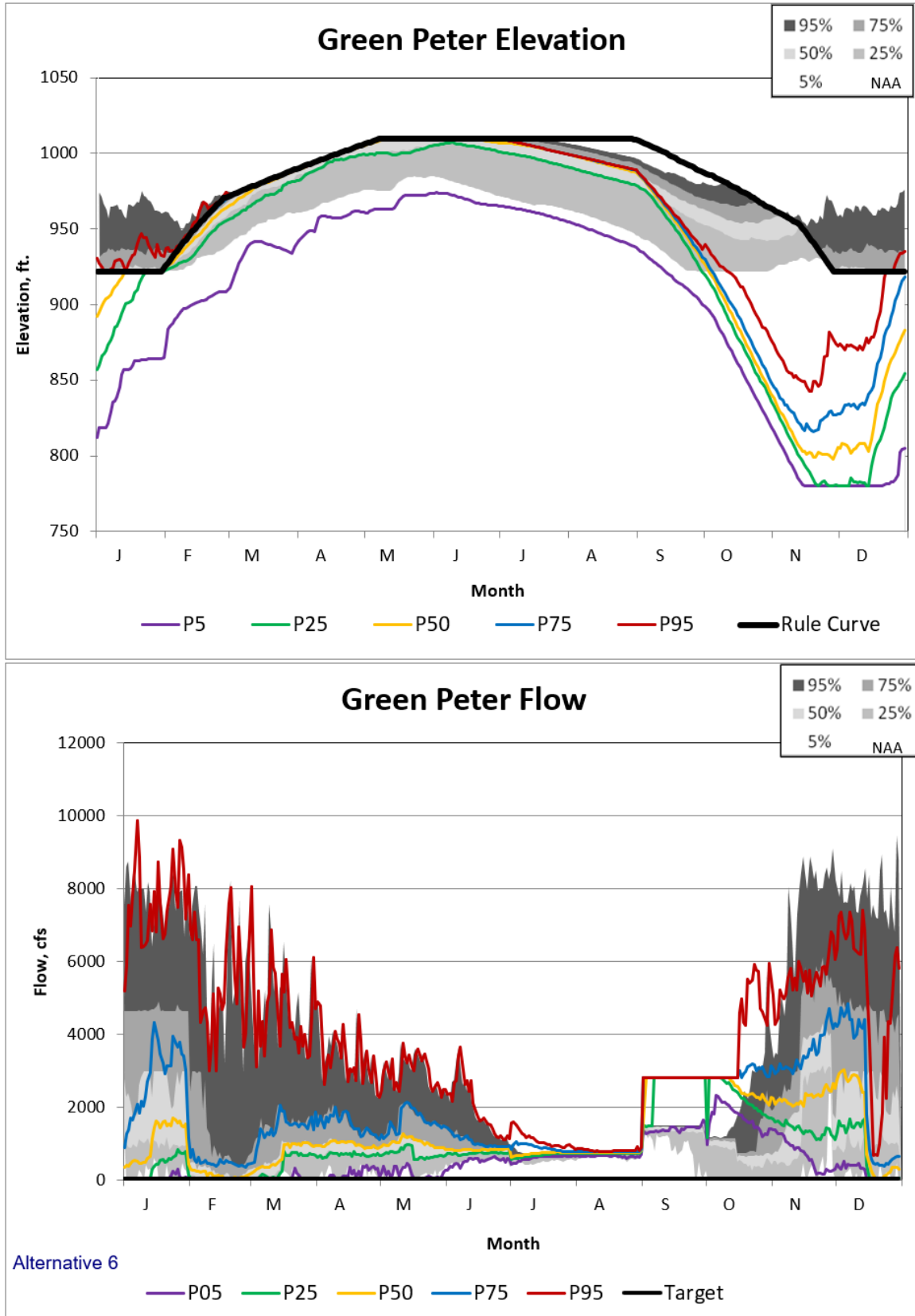

Figure 5-173. Green Peter Alternative 6 Non-exceedance Plot.

Willamette Valley System Operations and Maintenance
Environmental Impact Statement

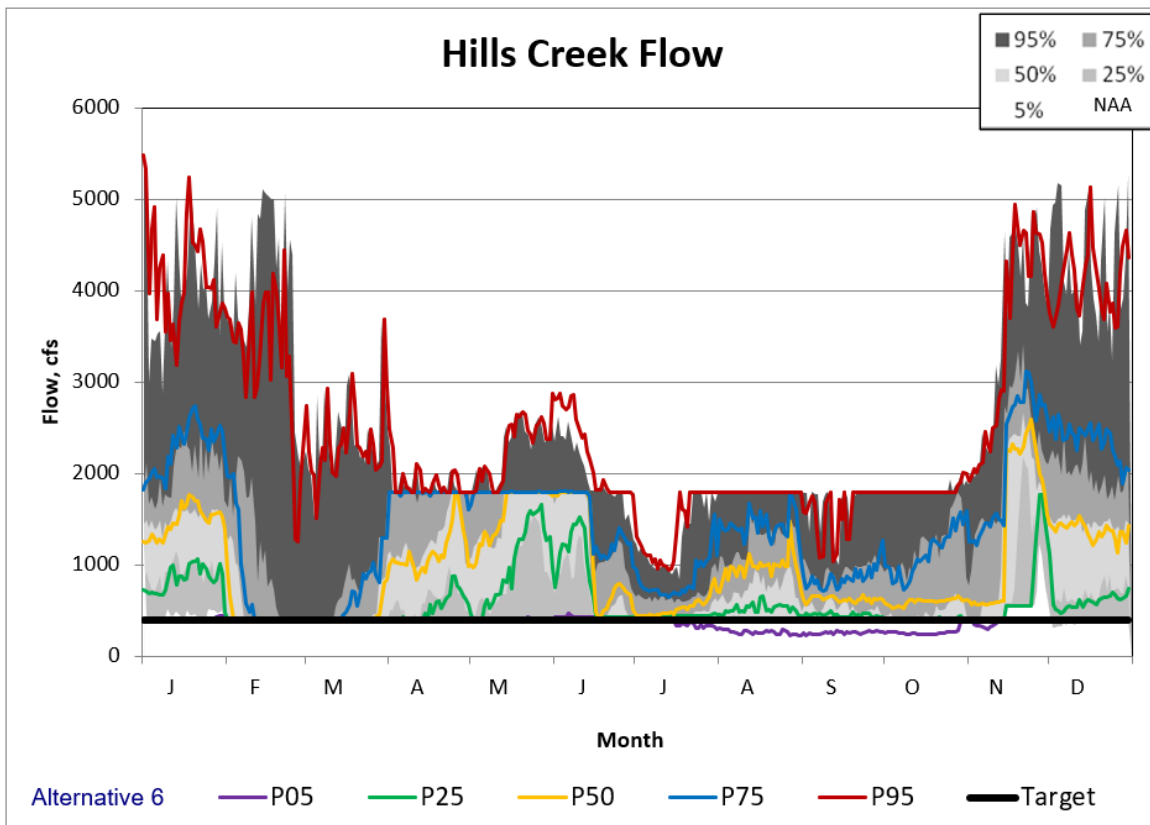
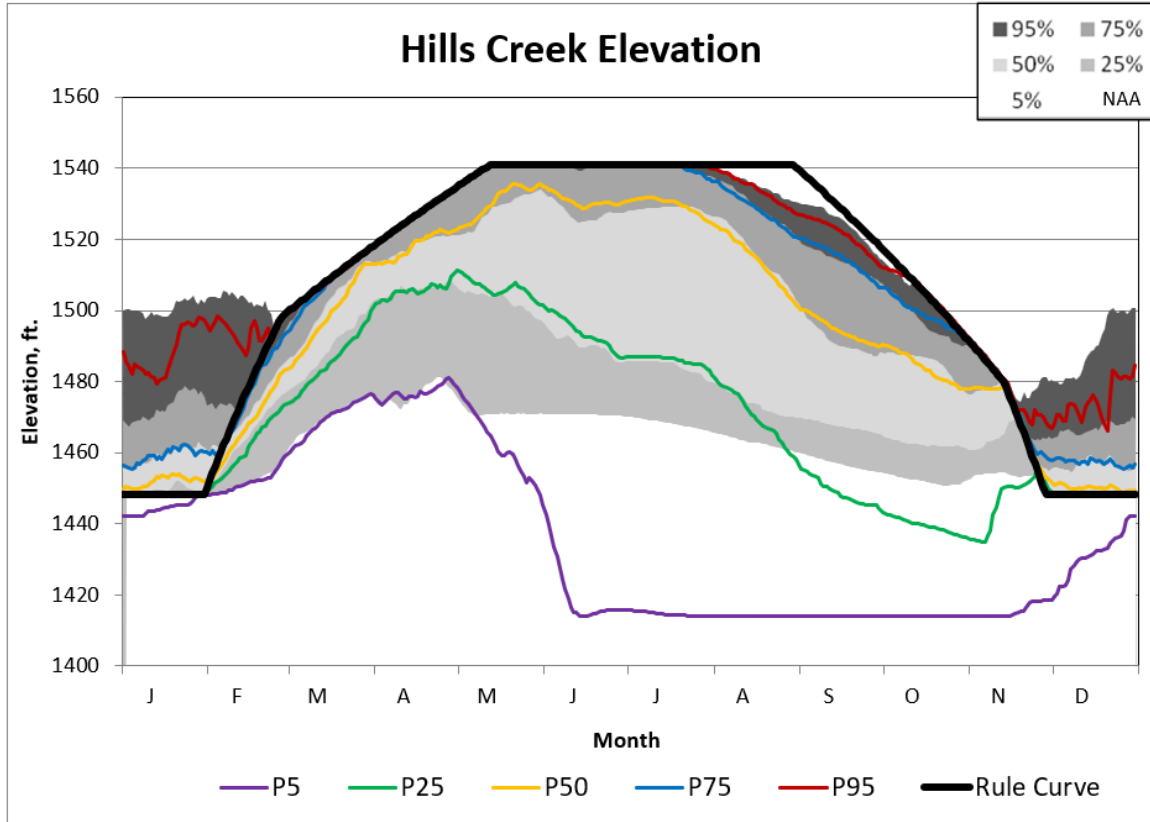

Figure 5-174. Hills Creek Alternative 6 Non-exceedance Plot.

Willamette Valley System Operations and Maintenance
Environmental Impact Statement

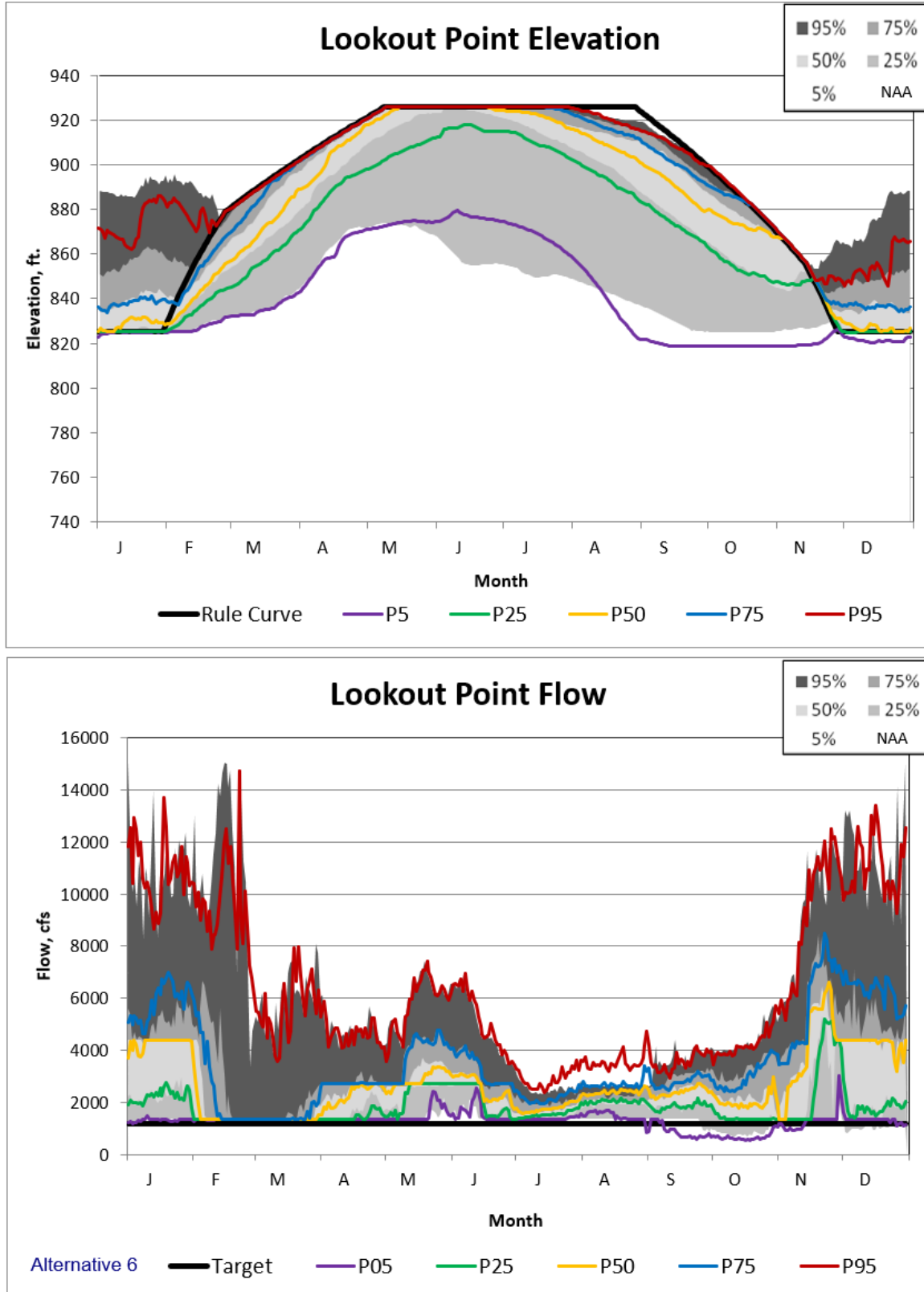

Figure 5-175. Lookout Point Alternative 6 Non-exceedance Plot.

Willamette Valley System Operations and Maintenance
Environmental Impact Statement

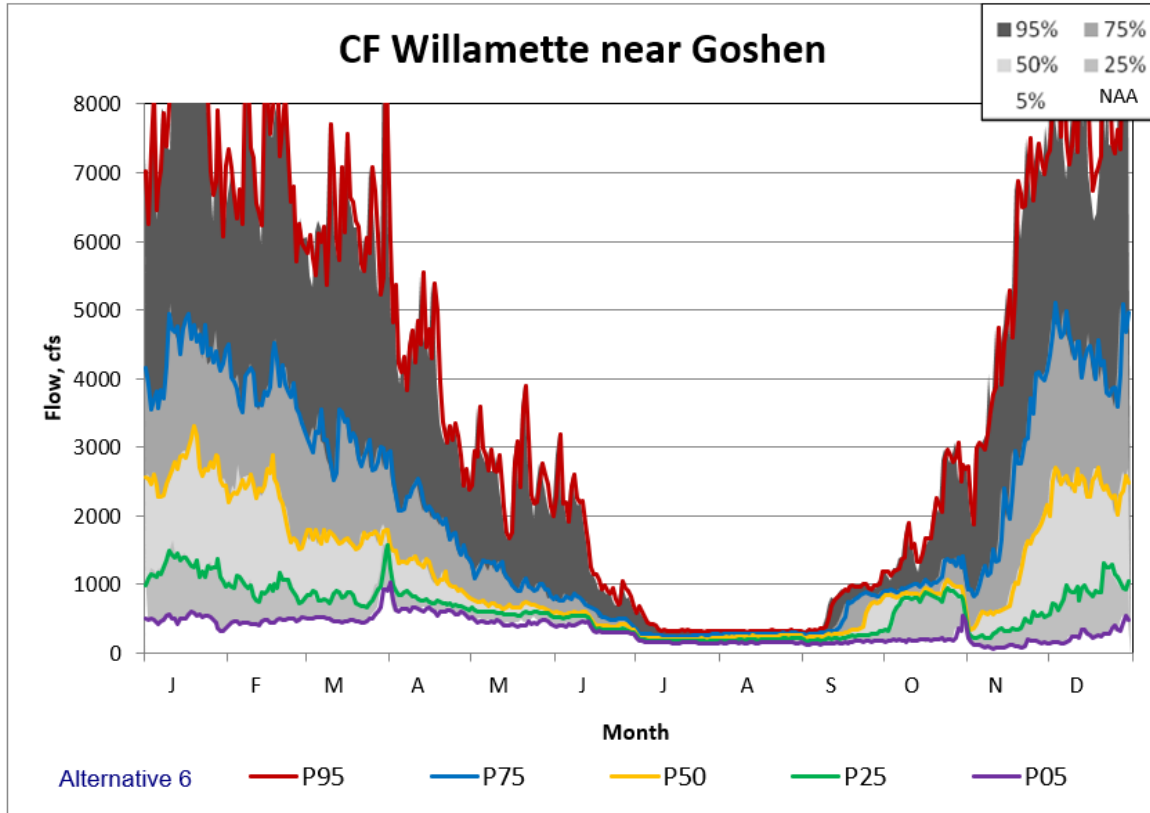

Figure 5-176. Goshen Alternative 6 Non-exceedance Plot.

Willamette Valley System Operations and Maintenance
Environmental Impact Statement

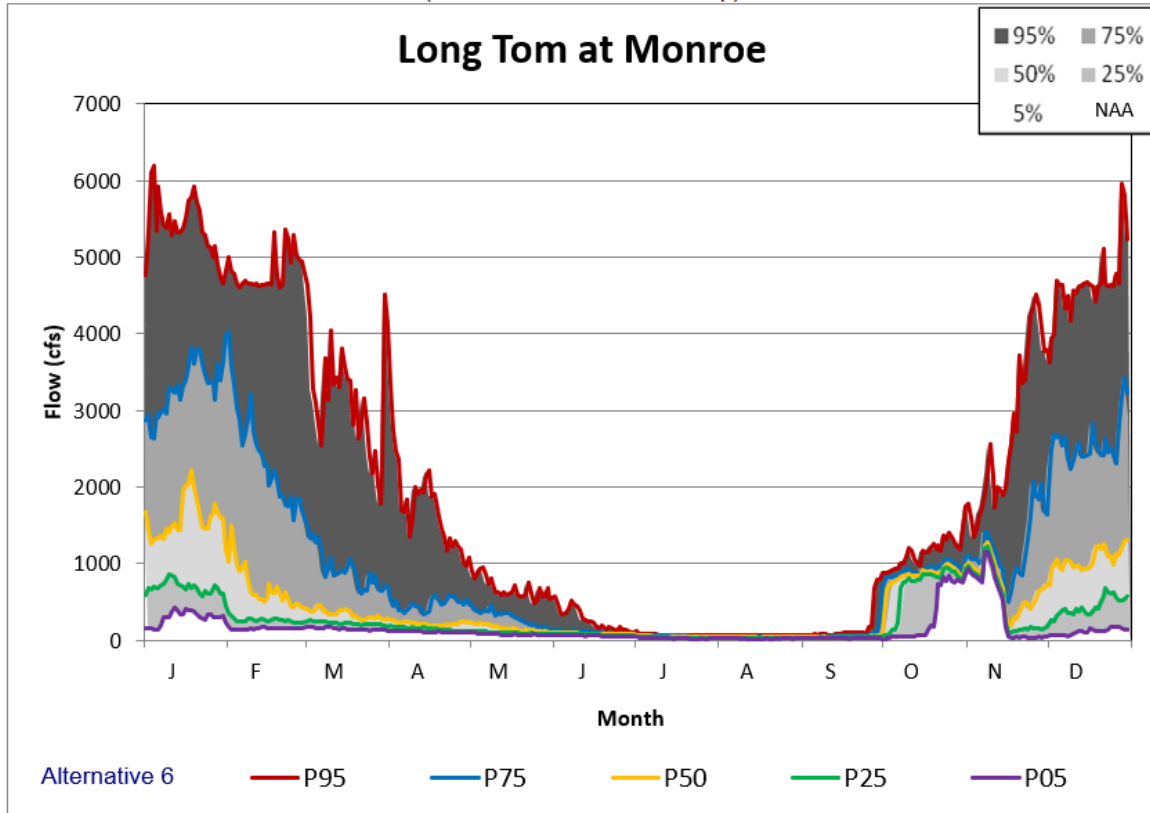

Figure 5-177. Monroe Alternative 6 Non-exceedance Plot.

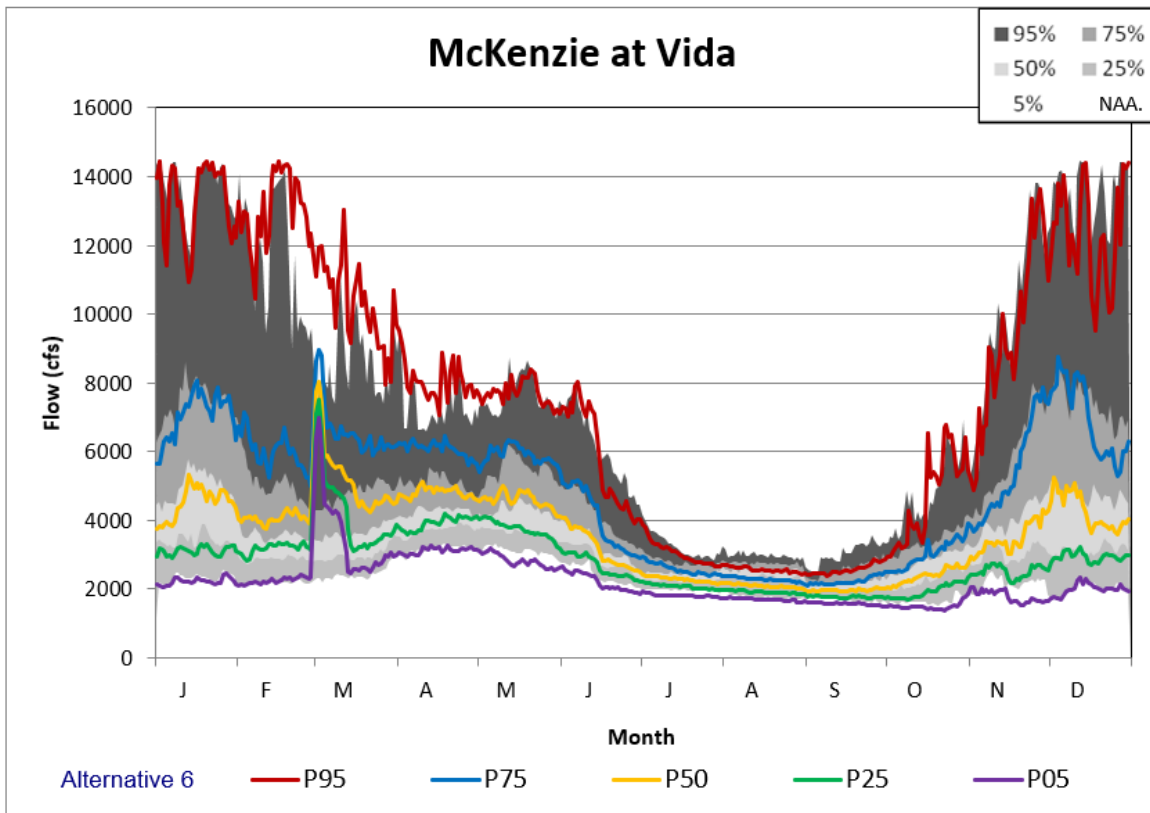

Figure 5-178. Vida Alternative 6 Non-exceedance Plot.

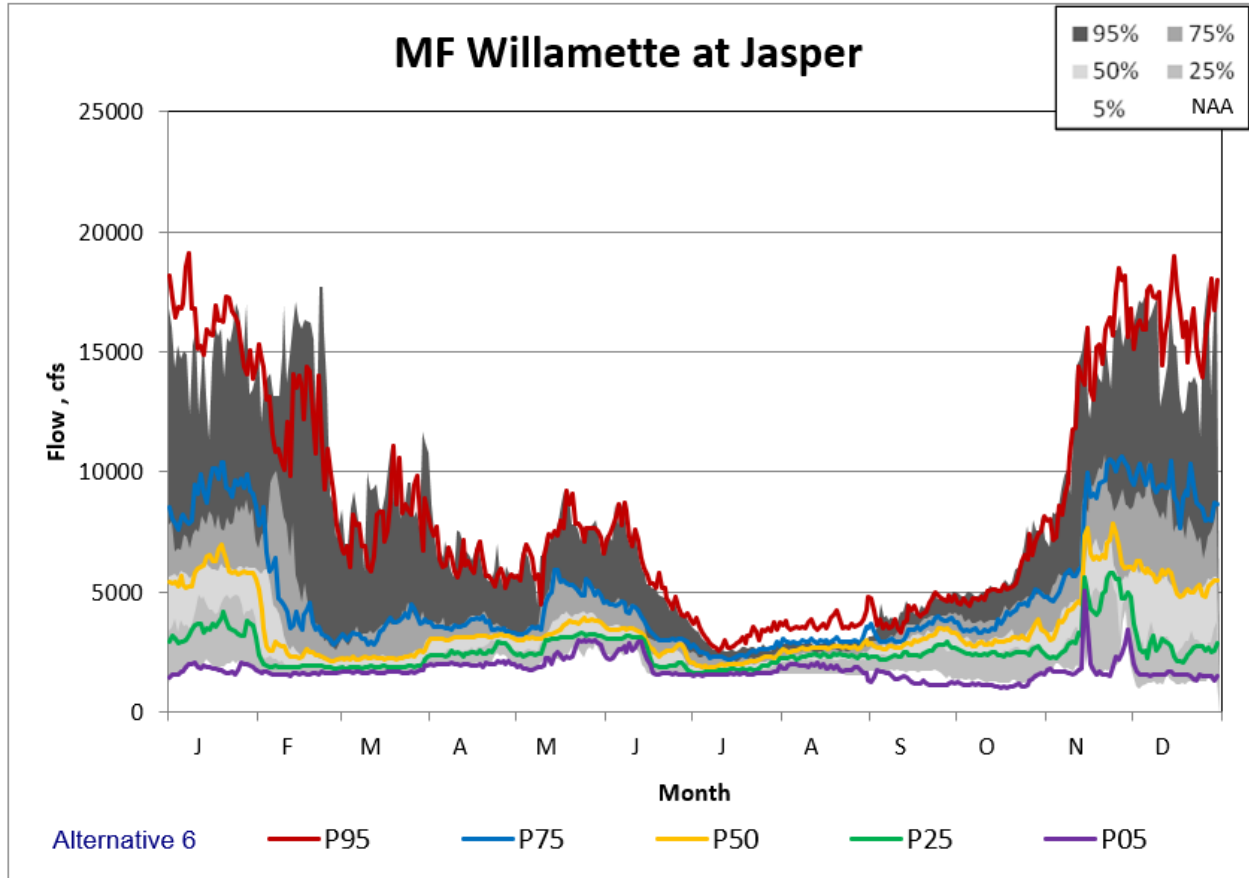

Figure 5-179. Jasper Alternative 6 Non-exceedance Plot.

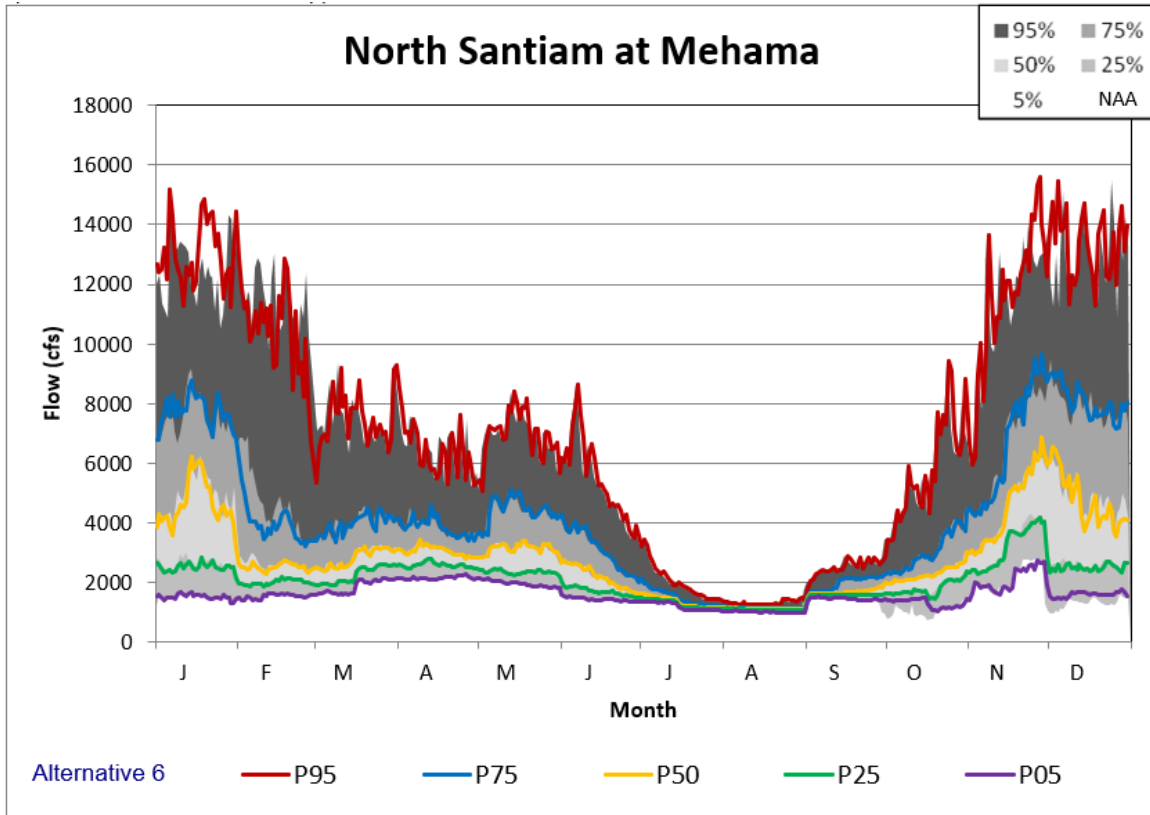

Figure 5-180. Mehama Alternative 6 Non-exceedance Plot.

Willamette Valley System Operations and Maintenance
Environmental Impact Statement

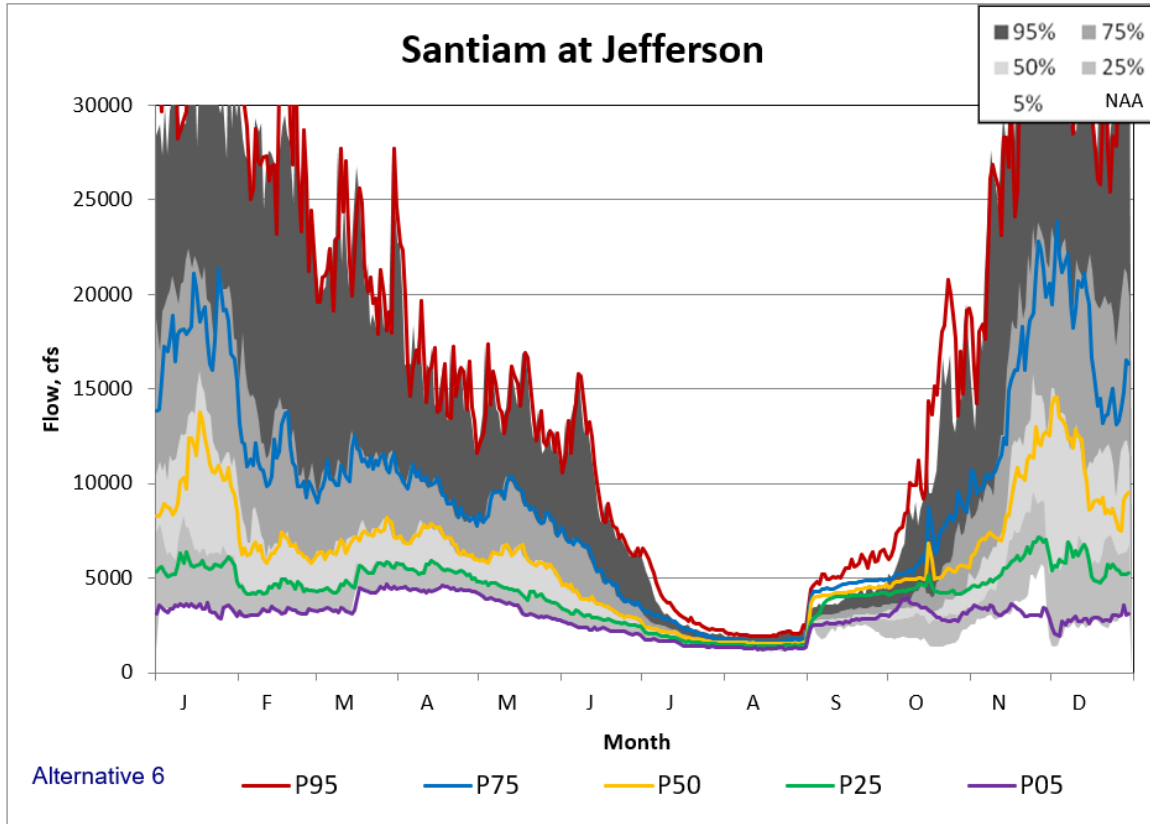

Figure 5-181. Jefferson Alternative 6 Non-exceedance Plot.

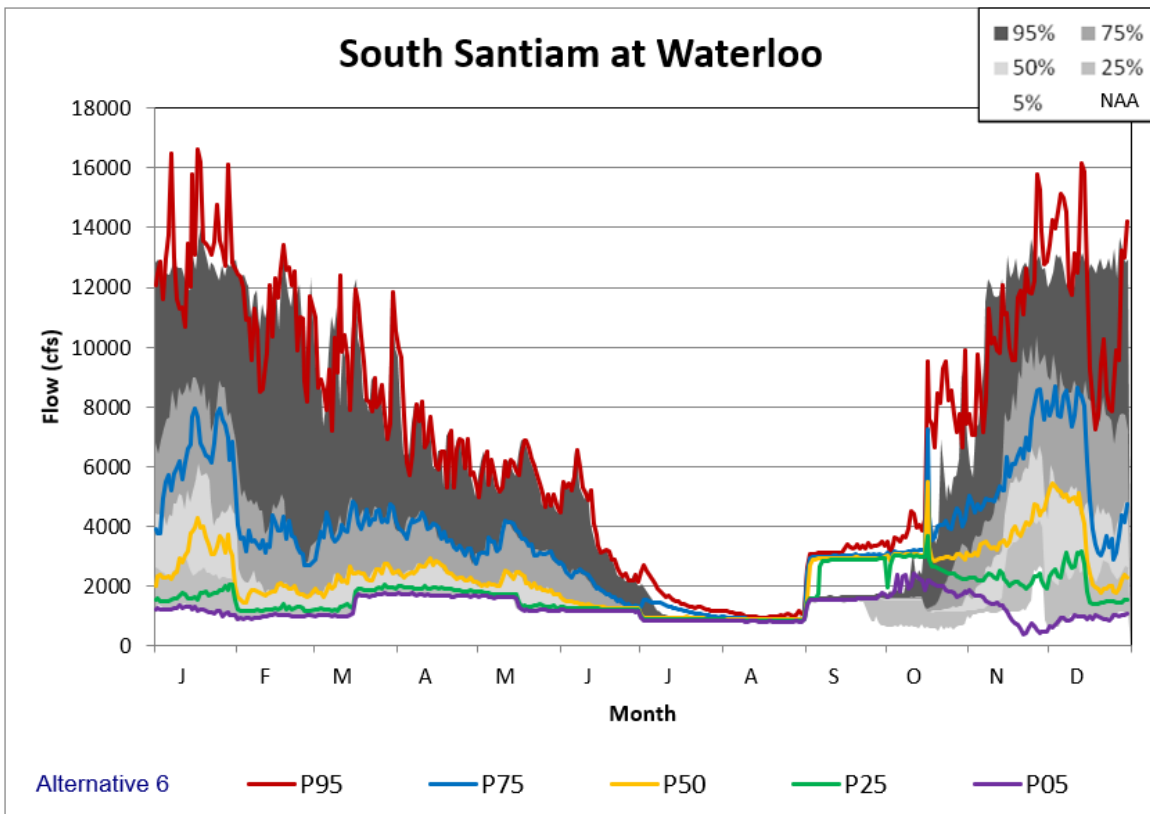

Figure 5-182. Waterloo Alternative 6 Non-exceedance Plot.

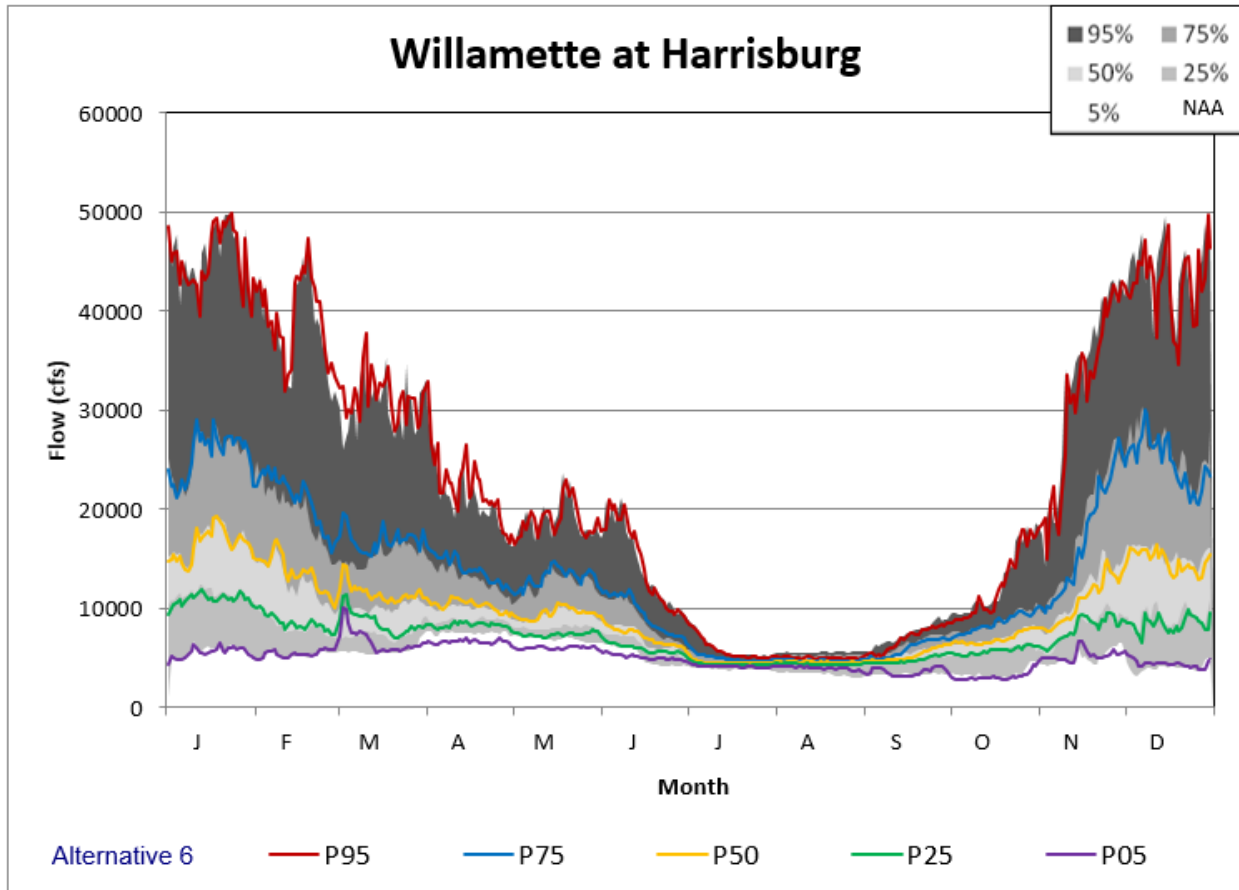

Figure 5-183. Harrisburg Alternative 6 Non-exceedance Plot.

Willamette Valley System Operations and Maintenance
Environmental Impact Statement

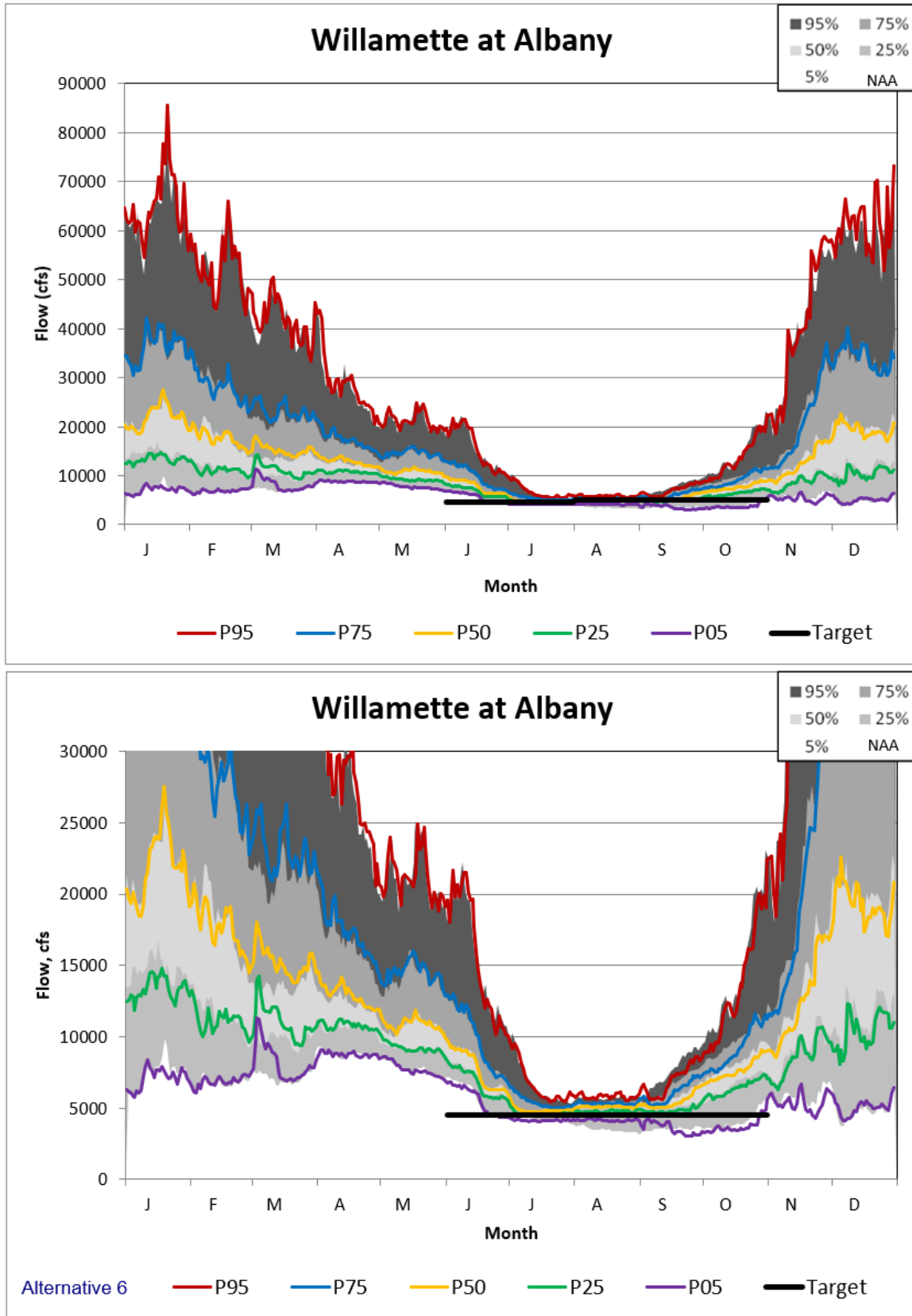

Figure 5-184. Albany Alternative 6 Non-exceedance Plot.

Willamette Valley System Operations and Maintenance
Environmental Impact Statement

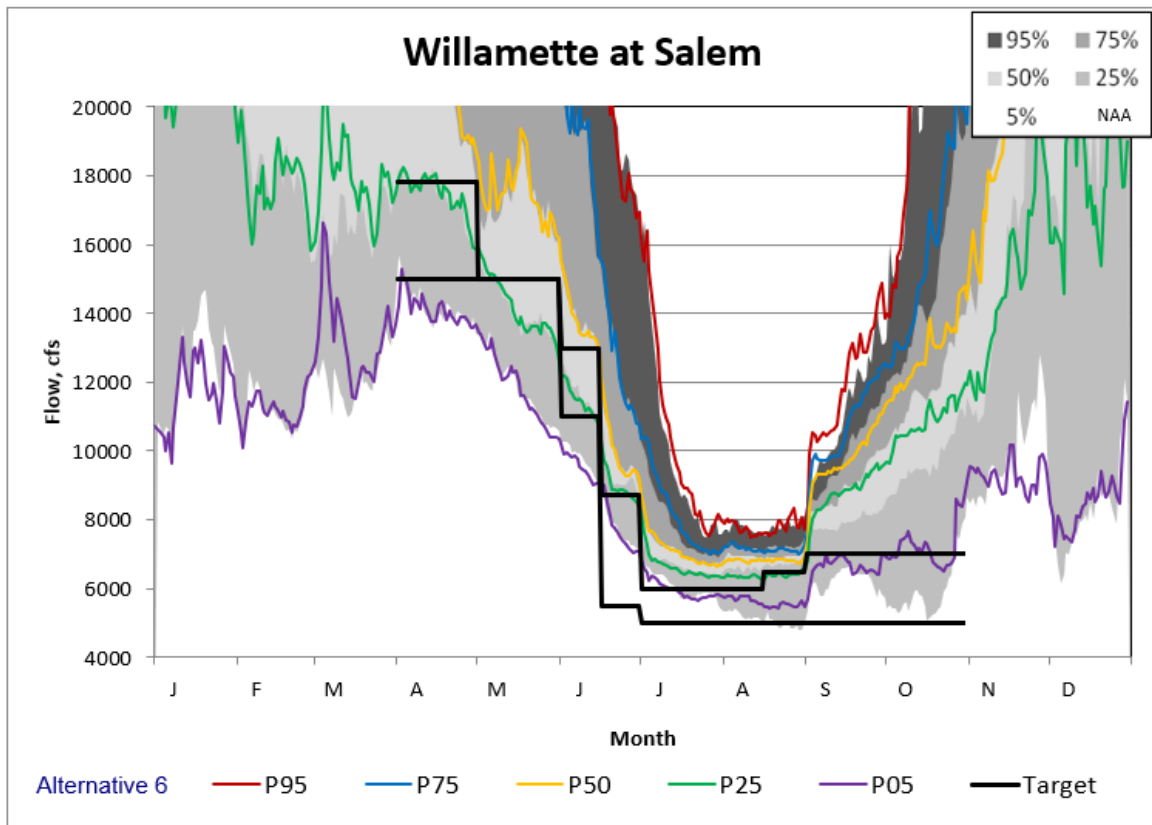
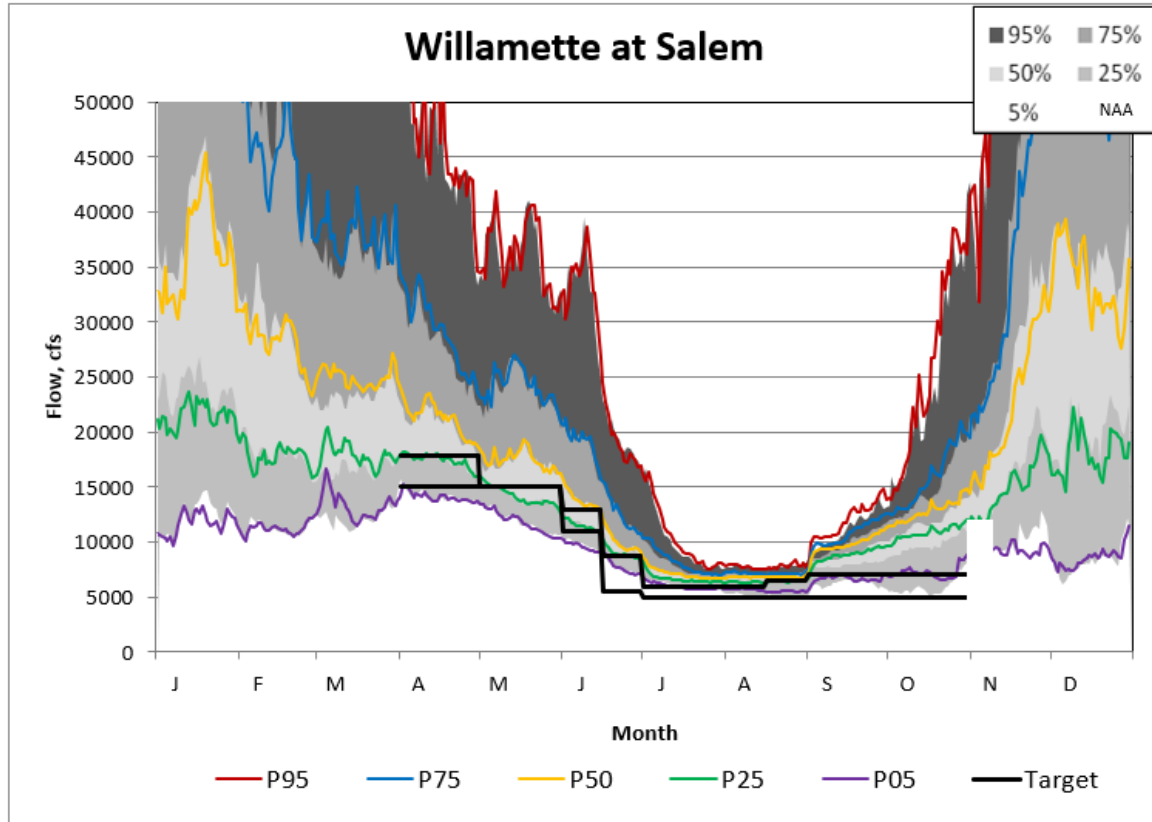

Figure 5-185. Salem Alternative 6 Non-exceedance Plot.

5.9 Interim Operations

*Willamette Valley System Operations and Maintenance
Environmental Impact Statement*

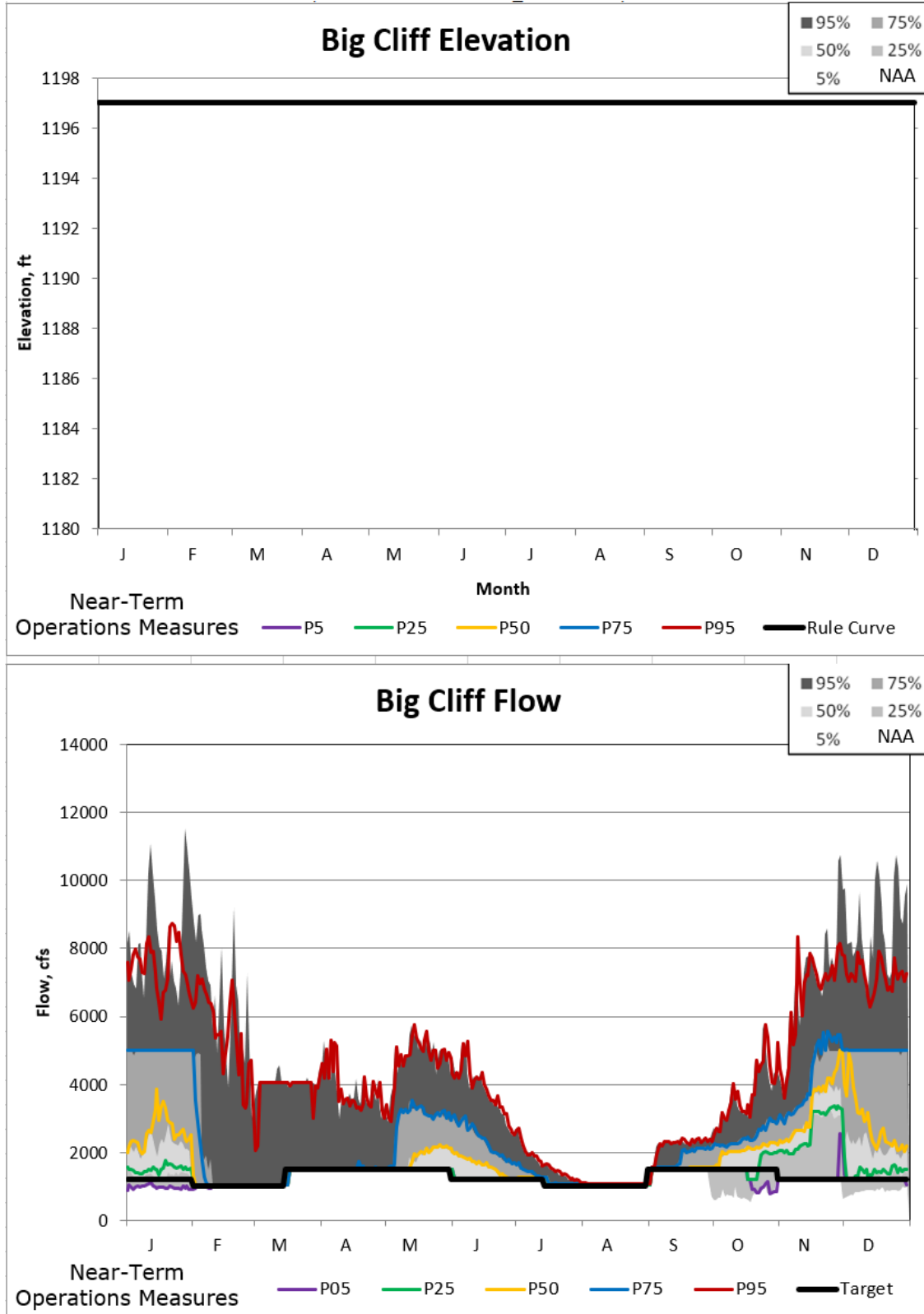

Figure 5-186. Big Cliff Interim Operations Non-exceedance Plot.

Willamette Valley System Operations and Maintenance
Environmental Impact Statement

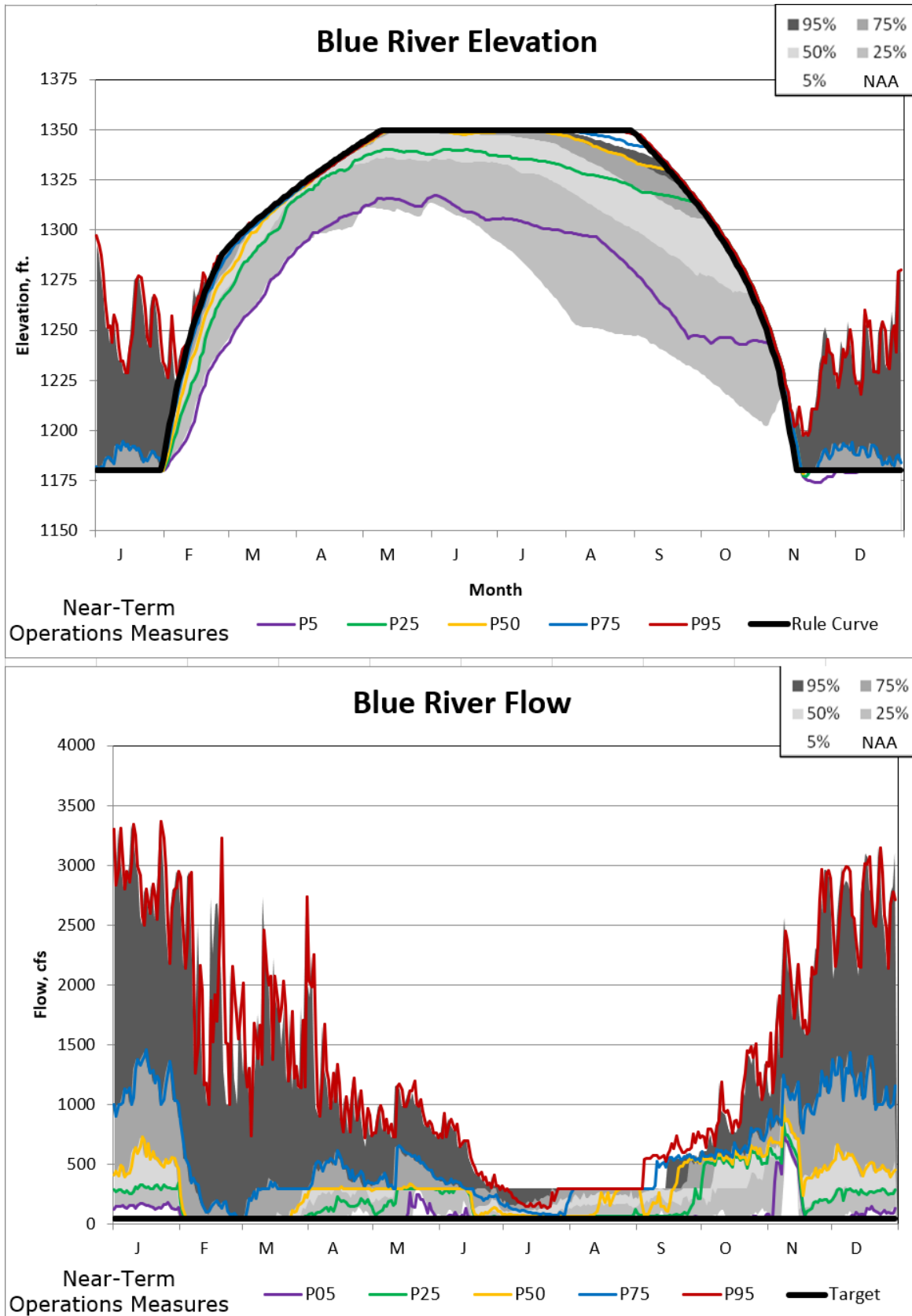

Figure 5-187. Blue River Interim Operations Non-exceedance Plot.

Willamette Valley System Operations and Maintenance
Environmental Impact Statement

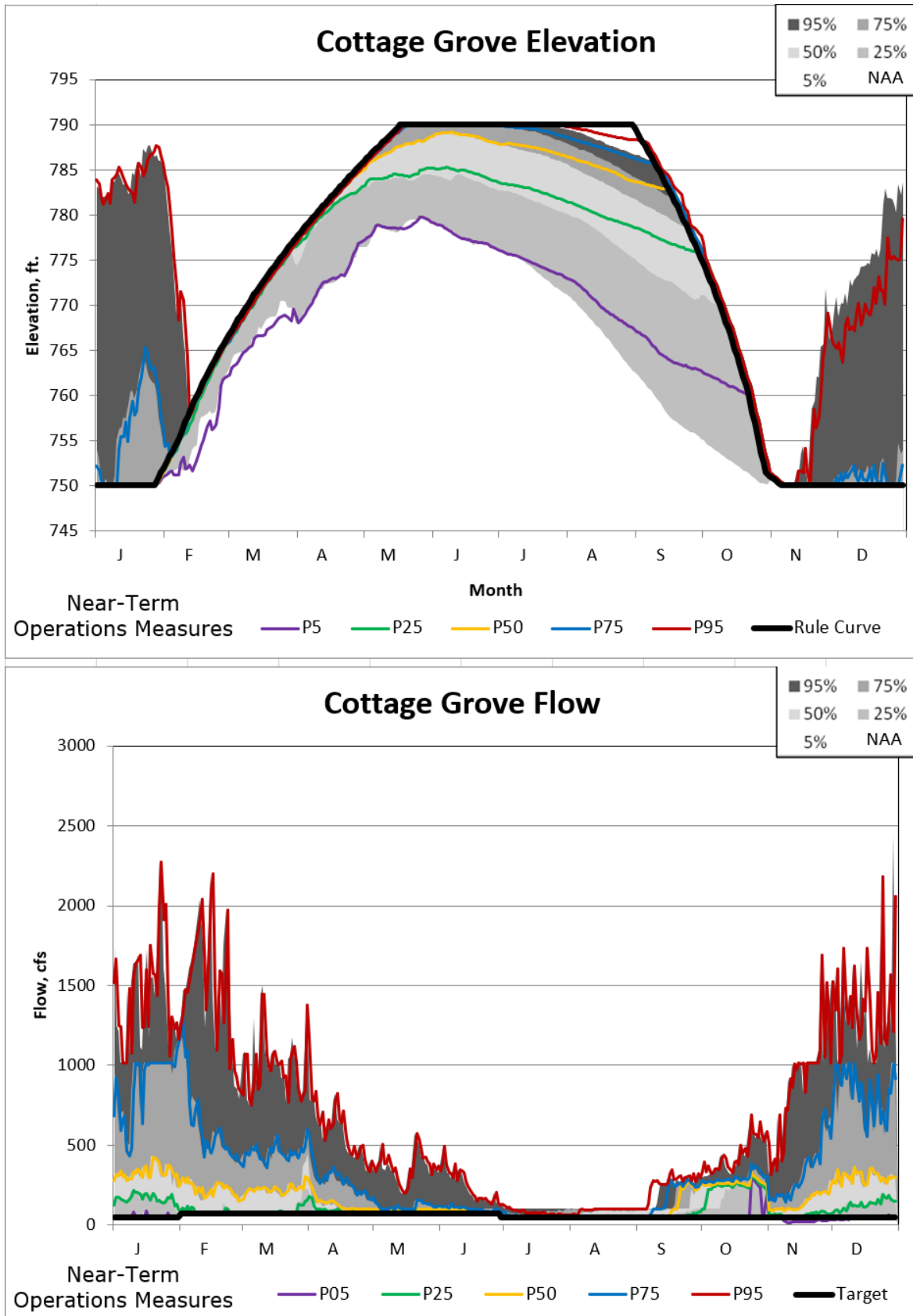

Figure 5-188. Cottage Grove Interim Operations Non-exceedance Plot.

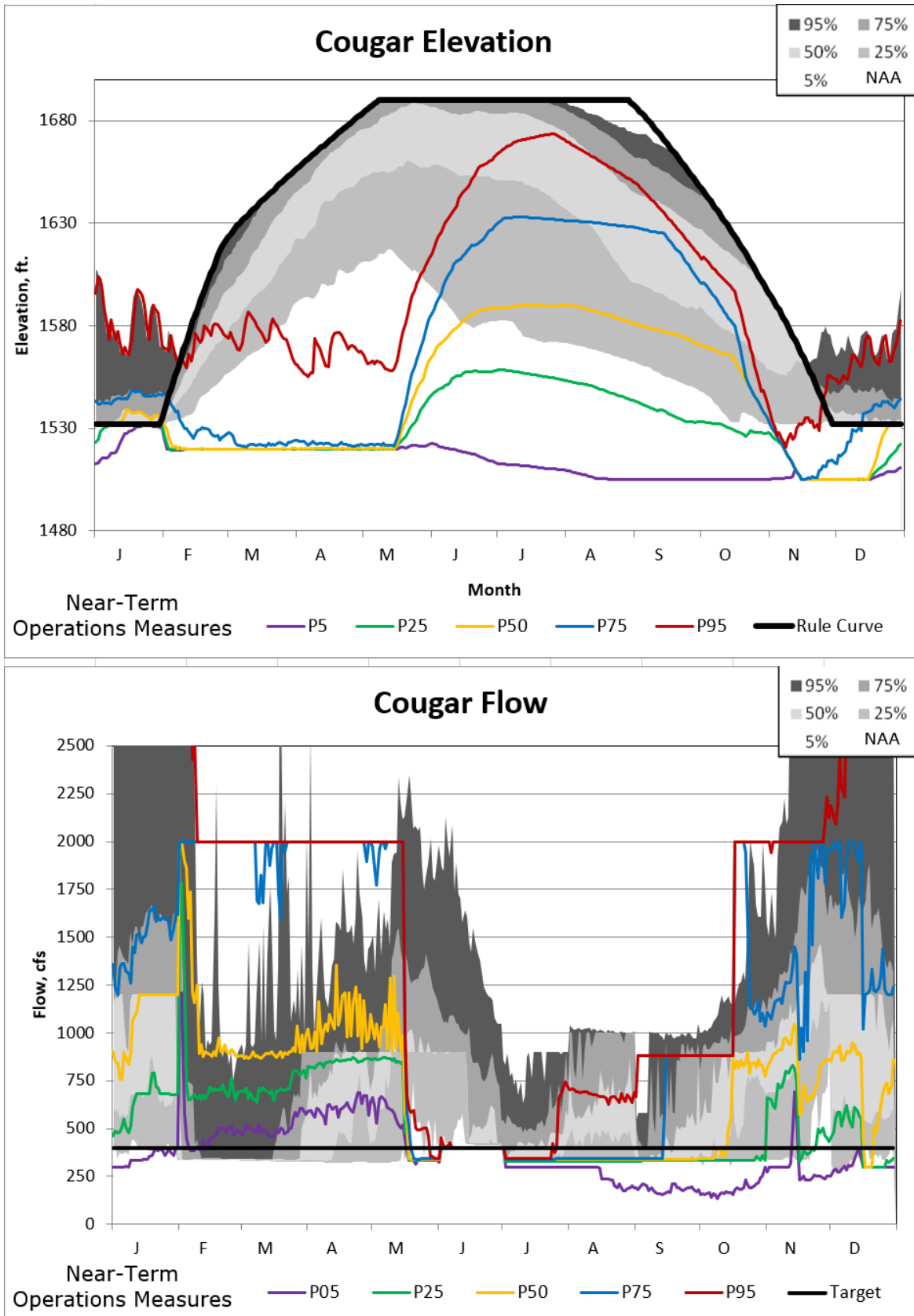

Figure 5-189. Cougar Interim Operations Non-exceedance Plot.

Willamette Valley System Operations and Maintenance
Environmental Impact Statement

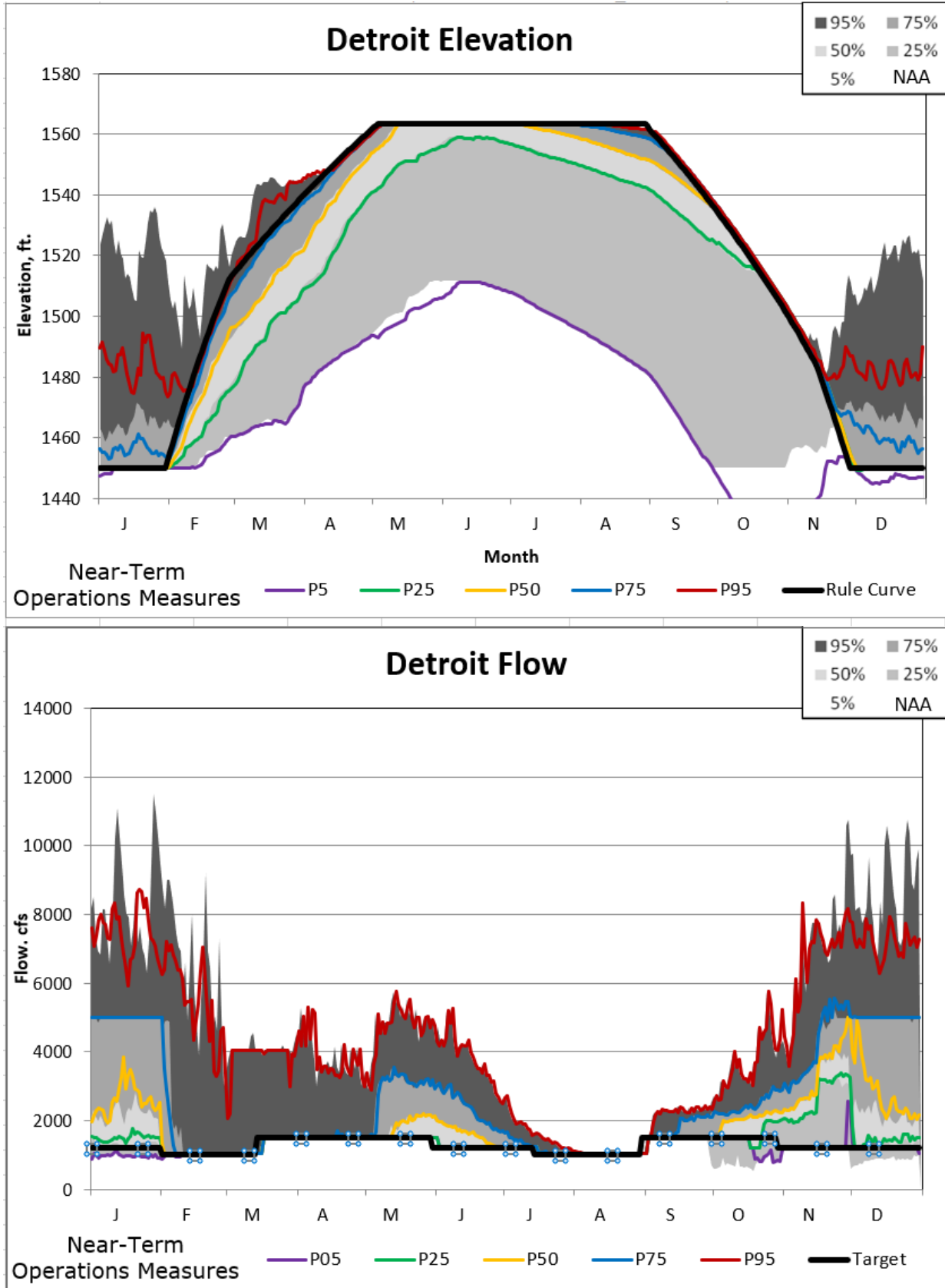

Figure 5-190. Detroit Interim Operations Non-exceedance Plot.

Willamette Valley System Operations and Maintenance
Environmental Impact Statement

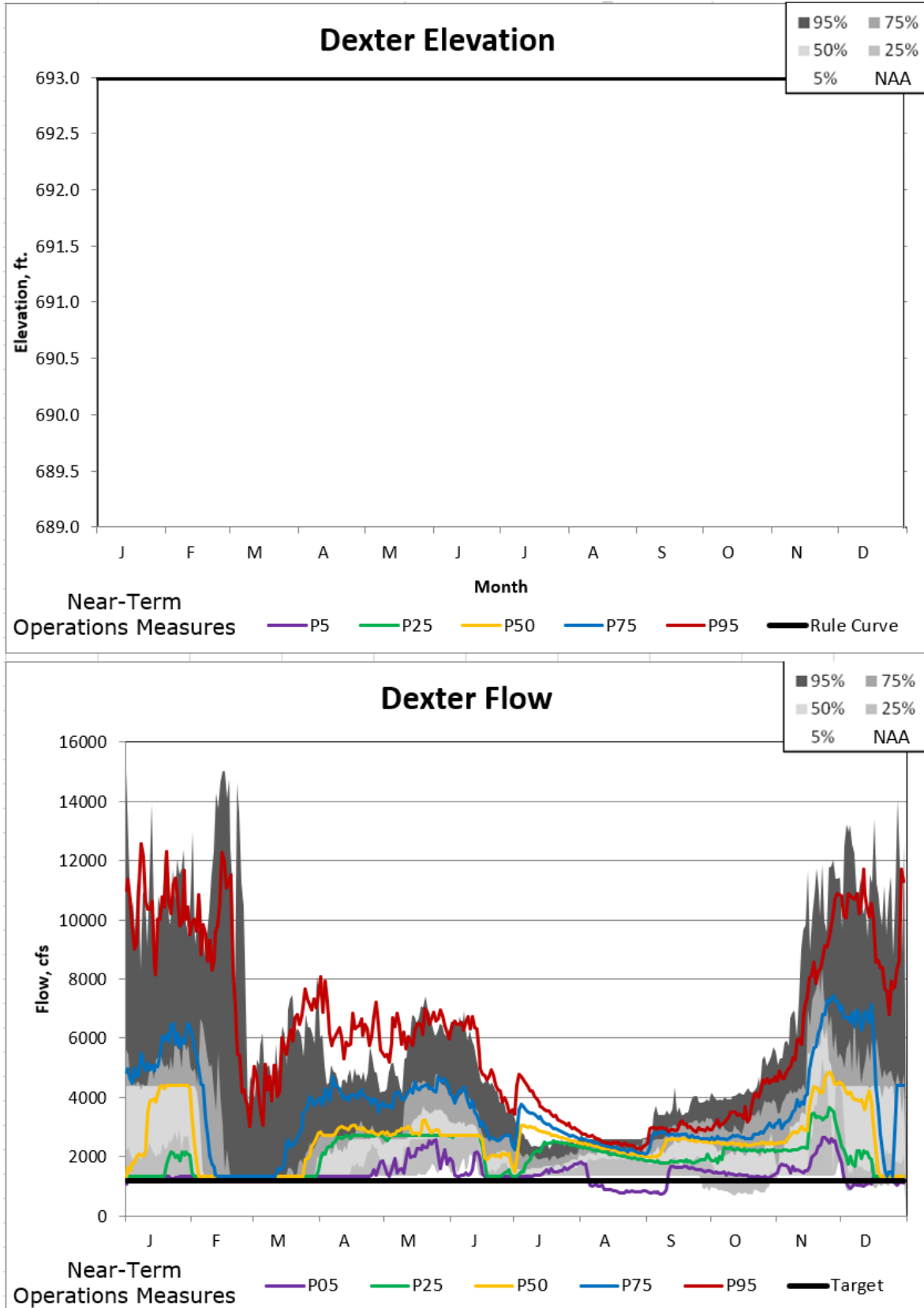

Figure 5-191. Dexter Interim Operations Non-exceedance Plot.

Willamette Valley System Operations and Maintenance
Environmental Impact Statement

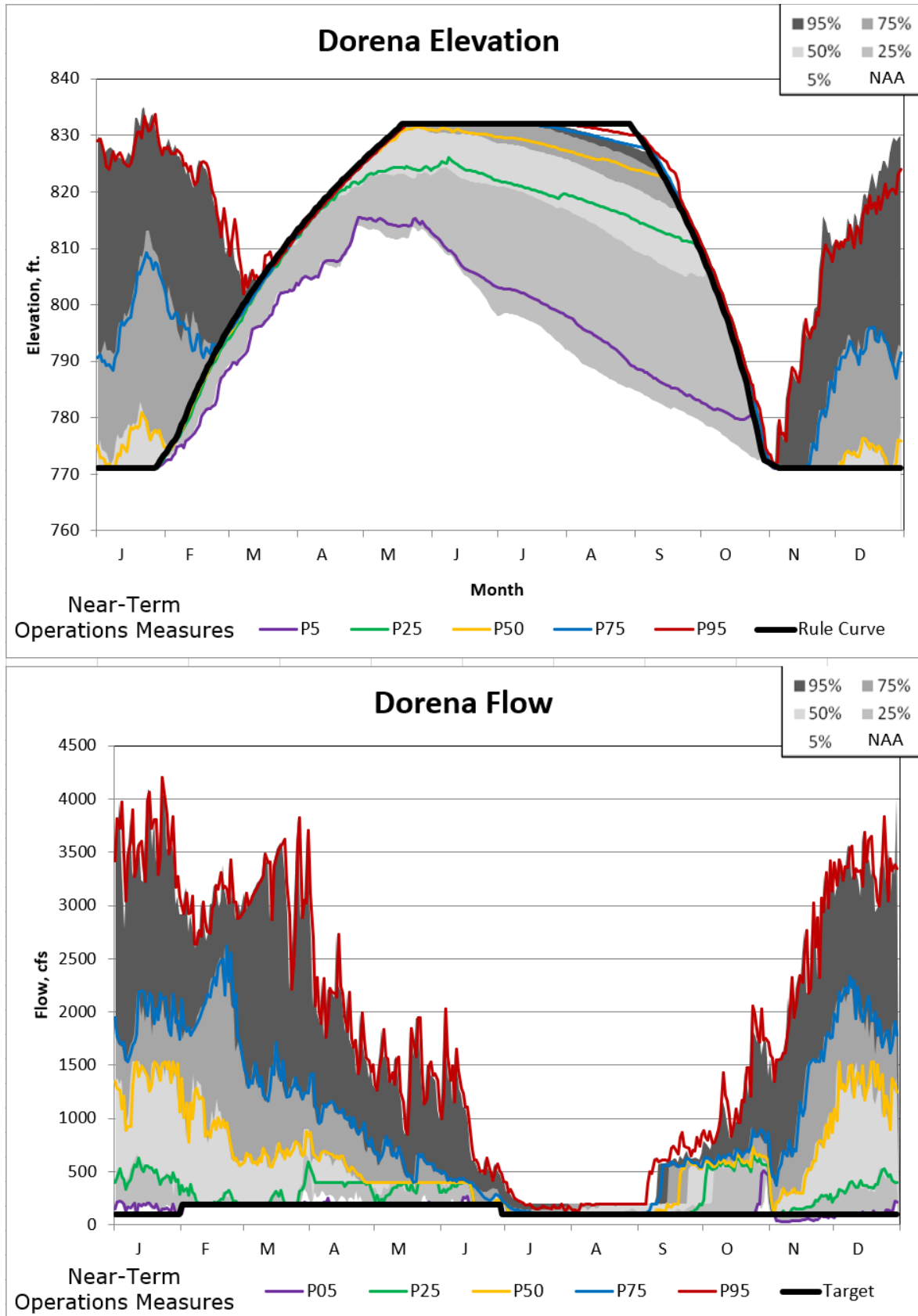

Figure 5-192. Dorena Interim Operations Non-exceedance Plot.

Willamette Valley System Operations and Maintenance
Environmental Impact Statement

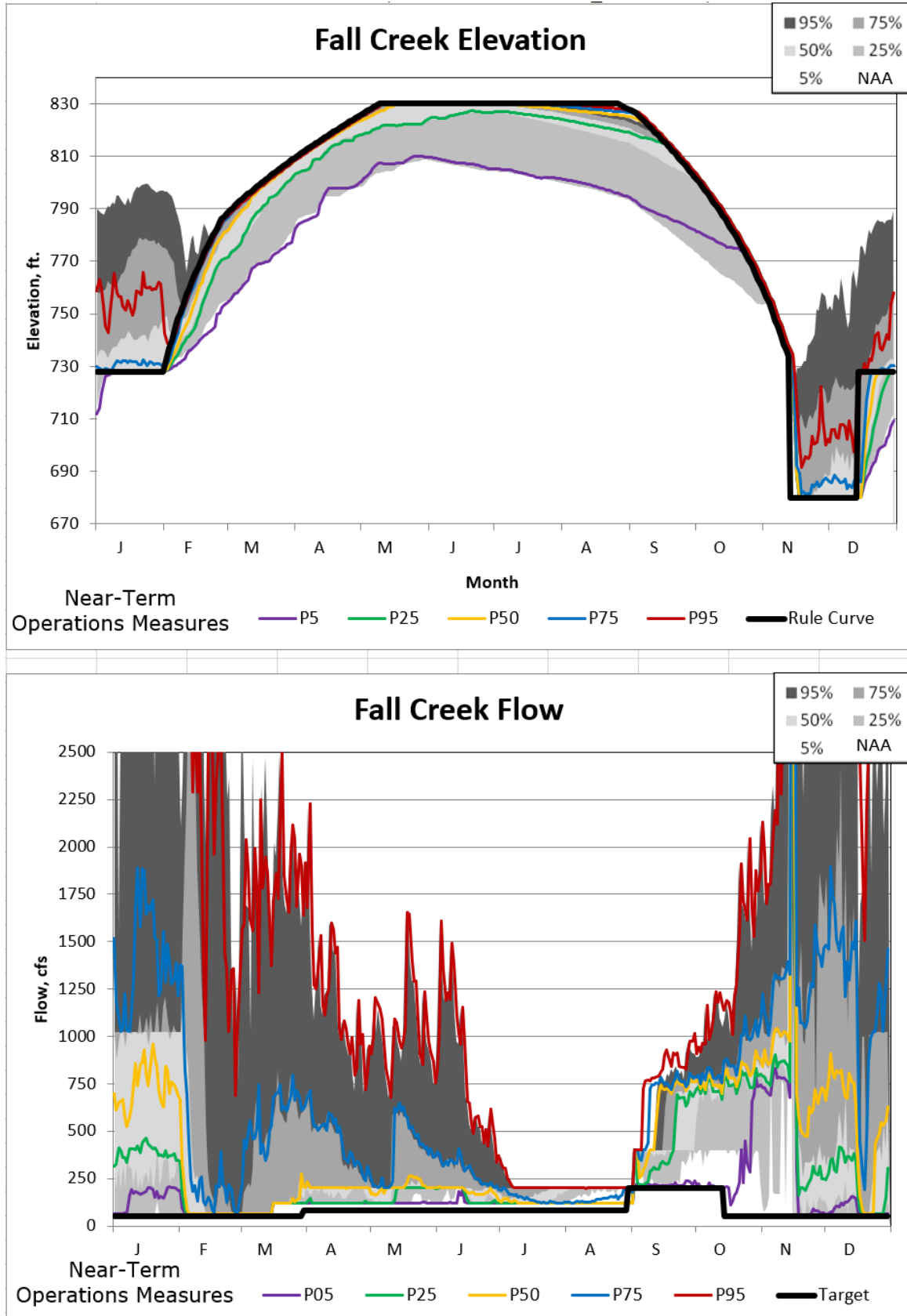

Figure 5-193. Fall Creek Interim Operations Non-exceedance Plot.

Willamette Valley System Operations and Maintenance
Environmental Impact Statement

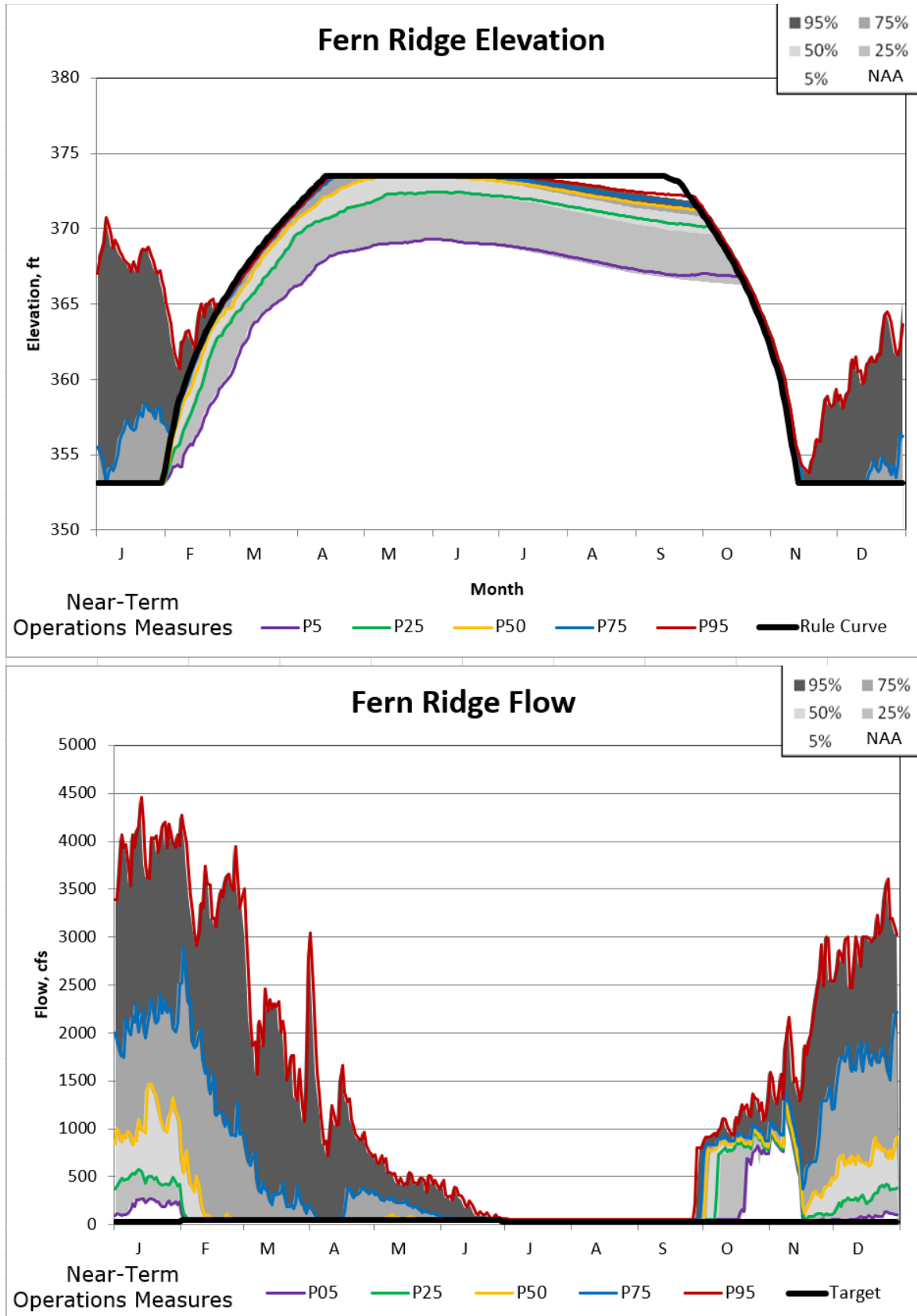

Figure 5-194. Fern Ridge Interim Operations Non-exceedance Plot.

Willamette Valley System Operations and Maintenance
Environmental Impact Statement

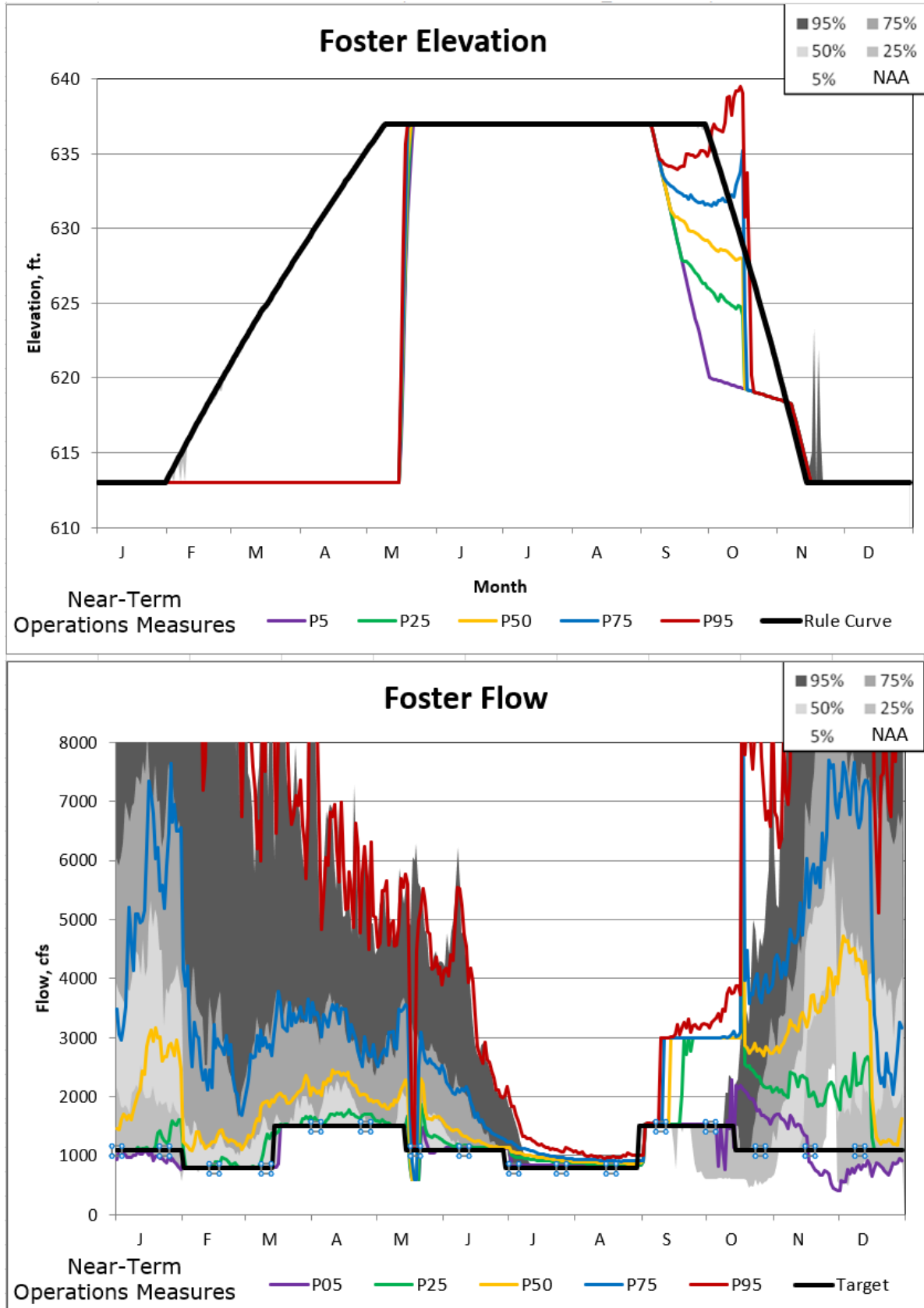

Figure 5-195. Foster Interim Operations Non-exceedance Plot.

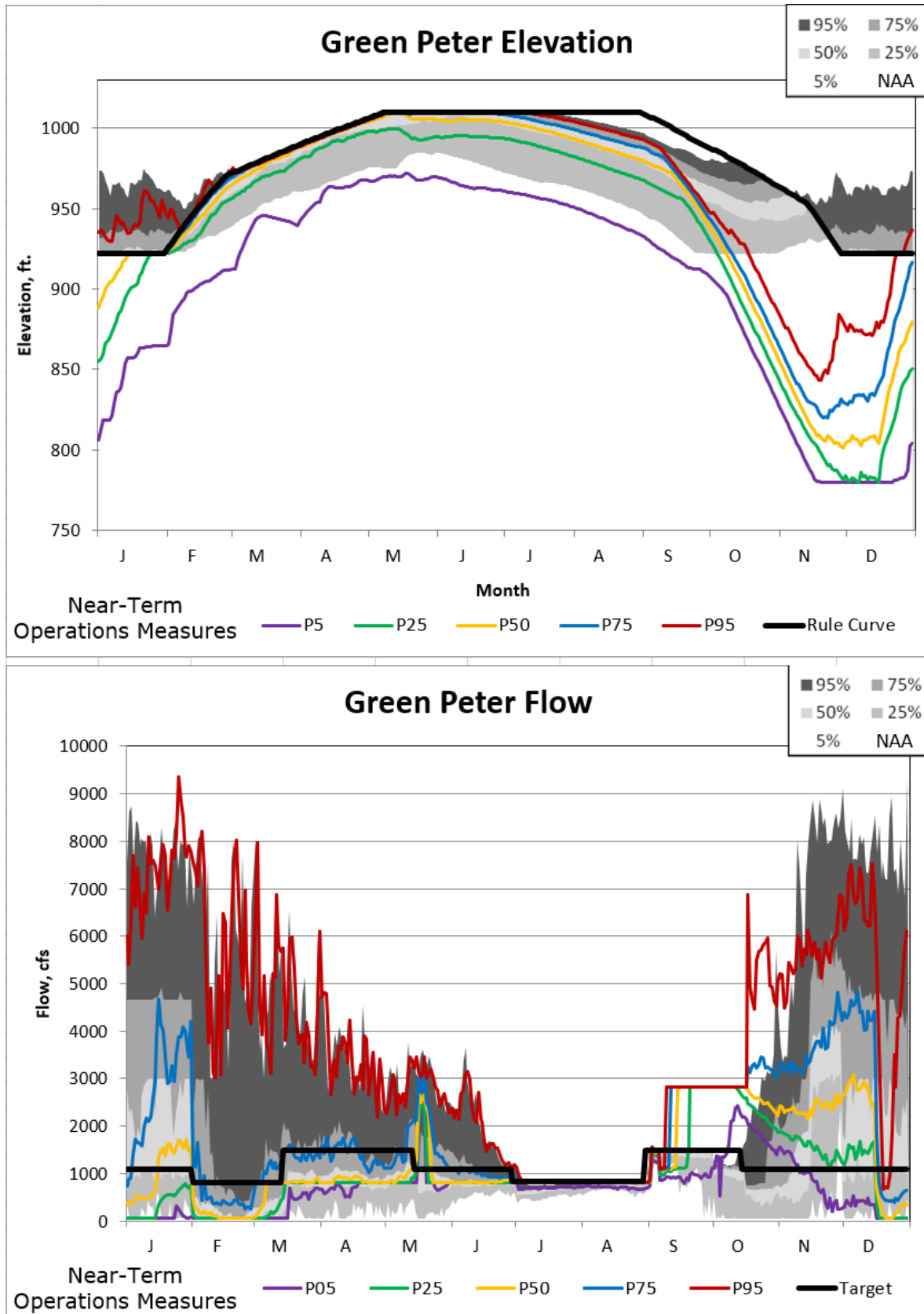

Figure 5-196. Green Peter Interim Operations Non-exceedance Plot.

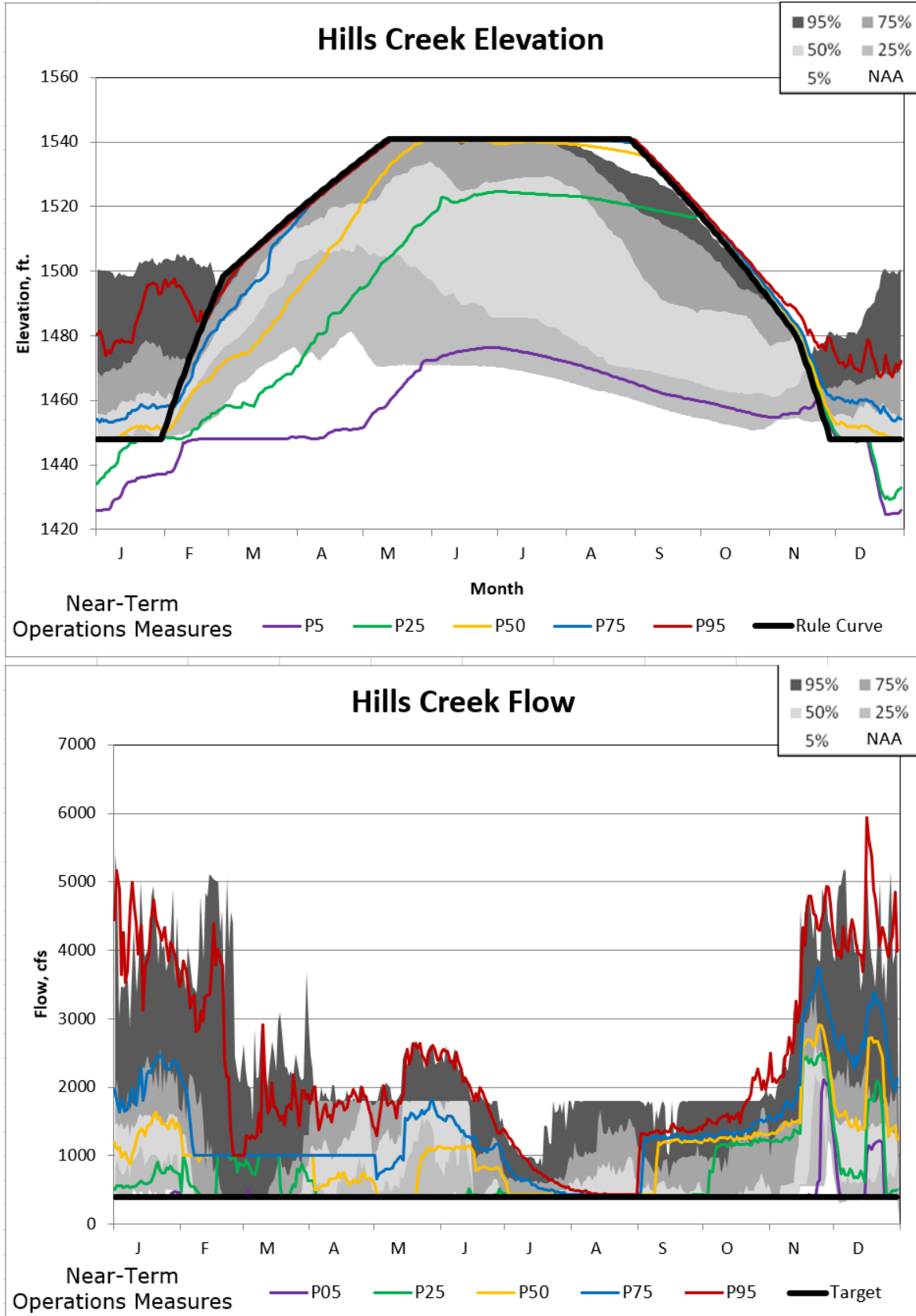

Figure 5-197. Hills Creek Interim Operations Non-exceedance Plot.

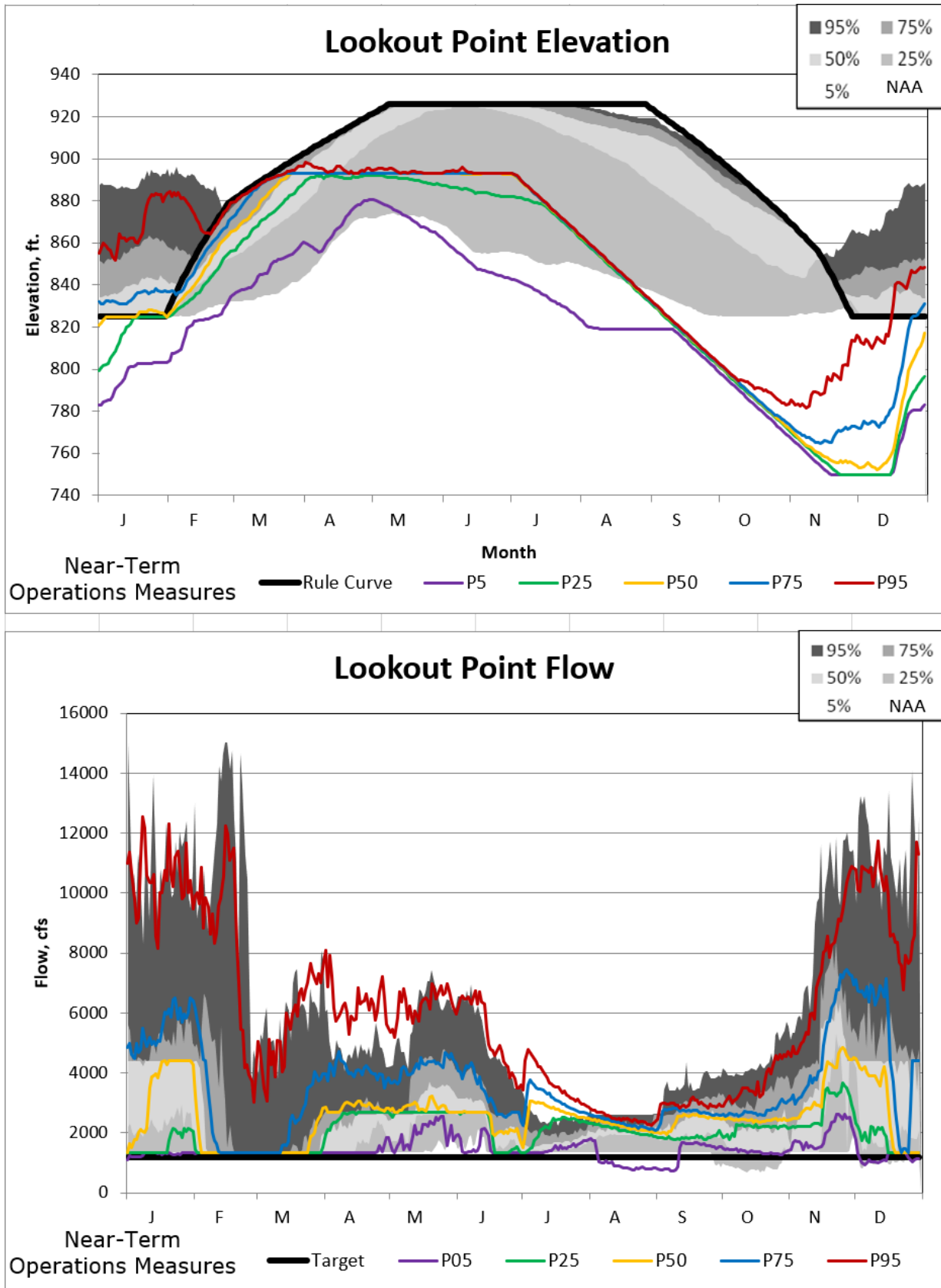

Figure 5-198. Lookout Point Interim Operations Non-exceedance Plot.

*Willamette Valley System Operations and Maintenance
Environmental Impact Statement*

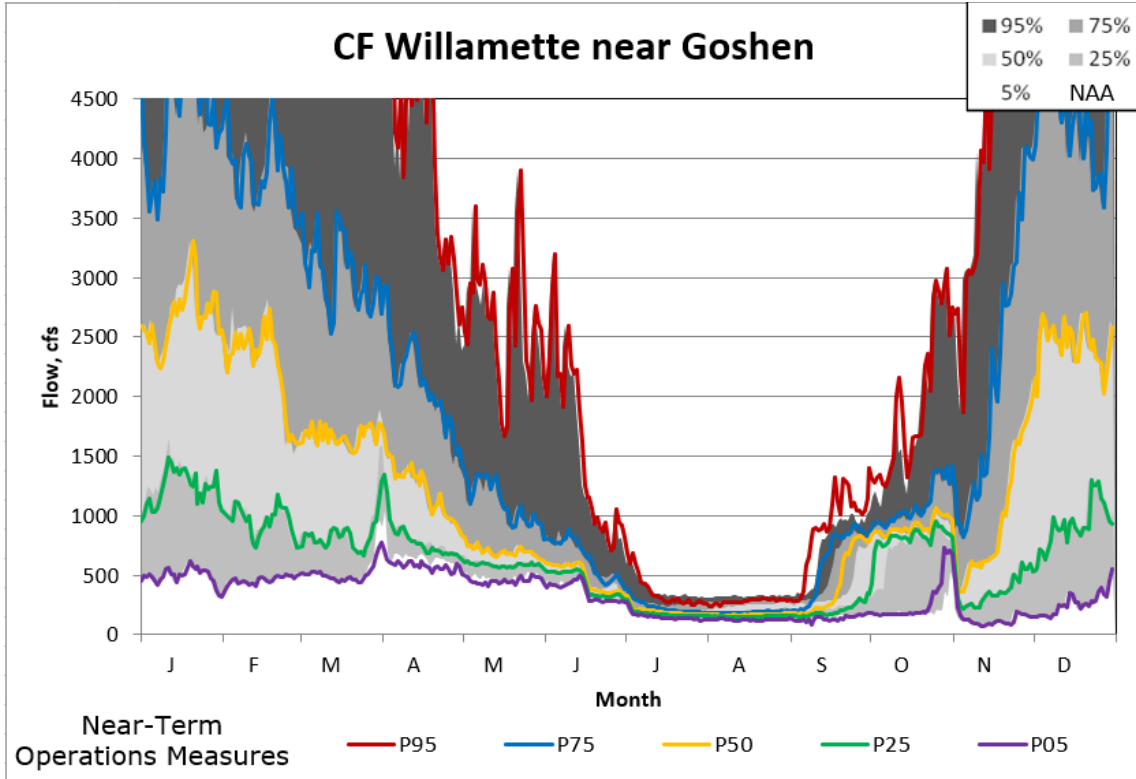

Figure 5-199. Goshen Interim Operations Non-exceedance Plot.

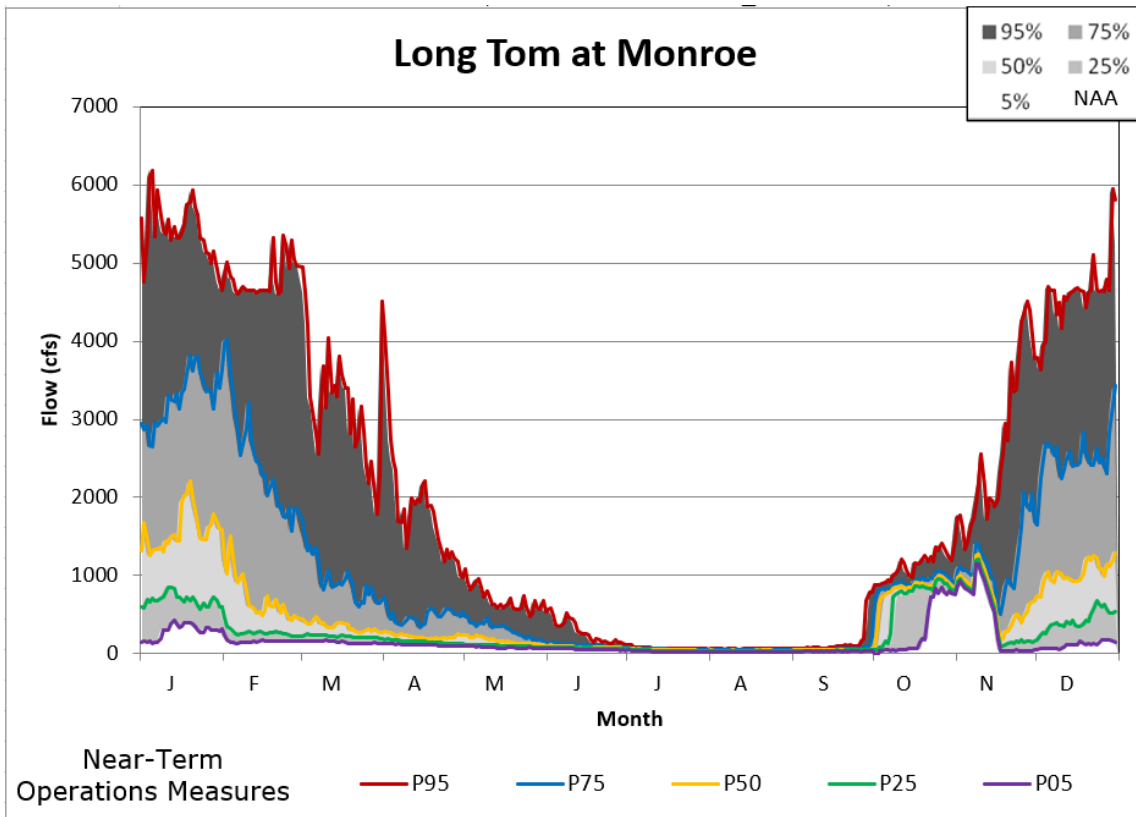

Figure 5-200. Monroe Interim Operations Non-exceedance Plot.

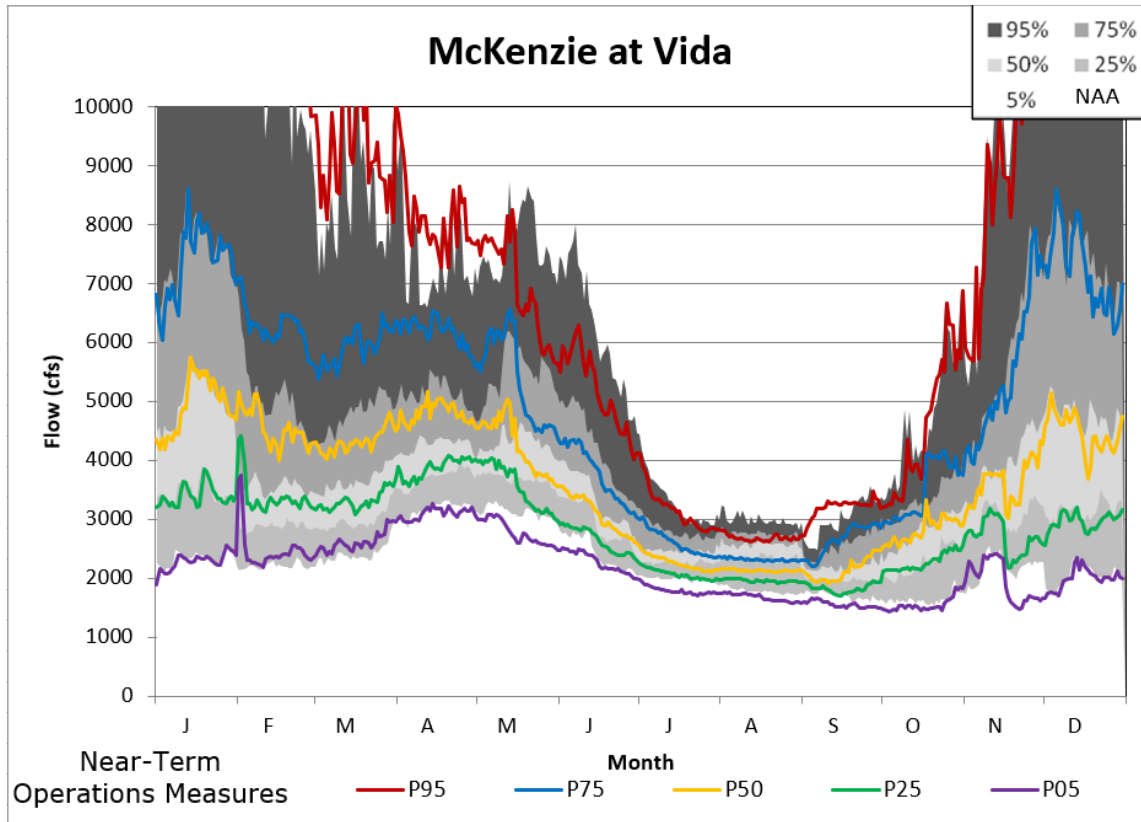

Figure 5-201. Vida Interim Operations Non-exceedance Plot.

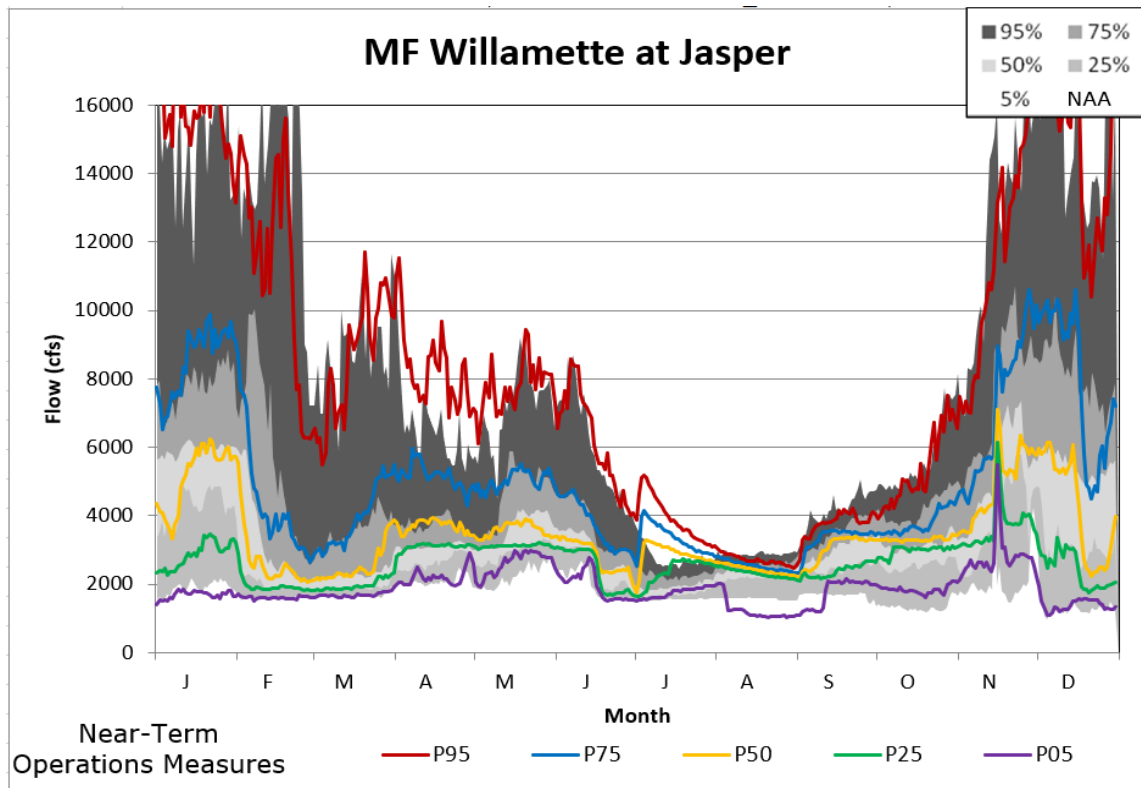

Figure 5-202. Jasper Interim Operations Non-exceedance Plot.

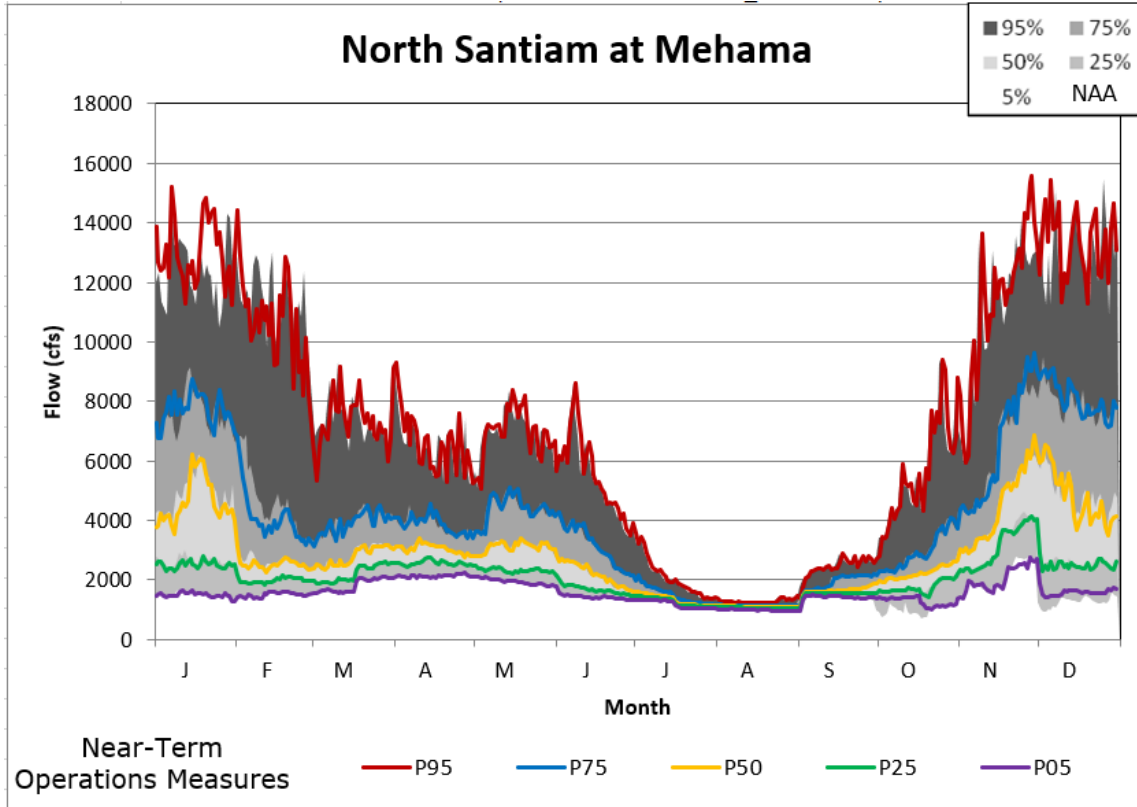

Figure 5-203. Mehama Interim Operations Non-exceedance Plot.

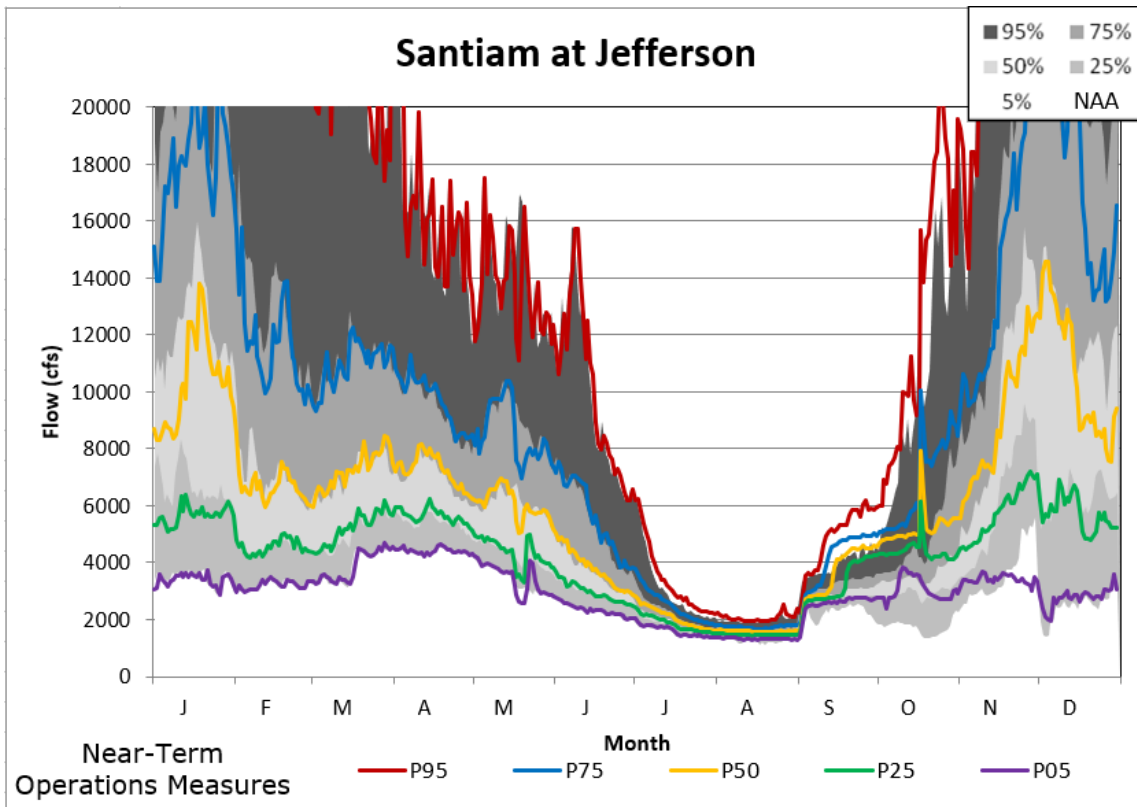

Figure 5-204. Jefferson Interim Operations Non-exceedance Plot.

*Willamette Valley System Operations and Maintenance
Environmental Impact Statement*

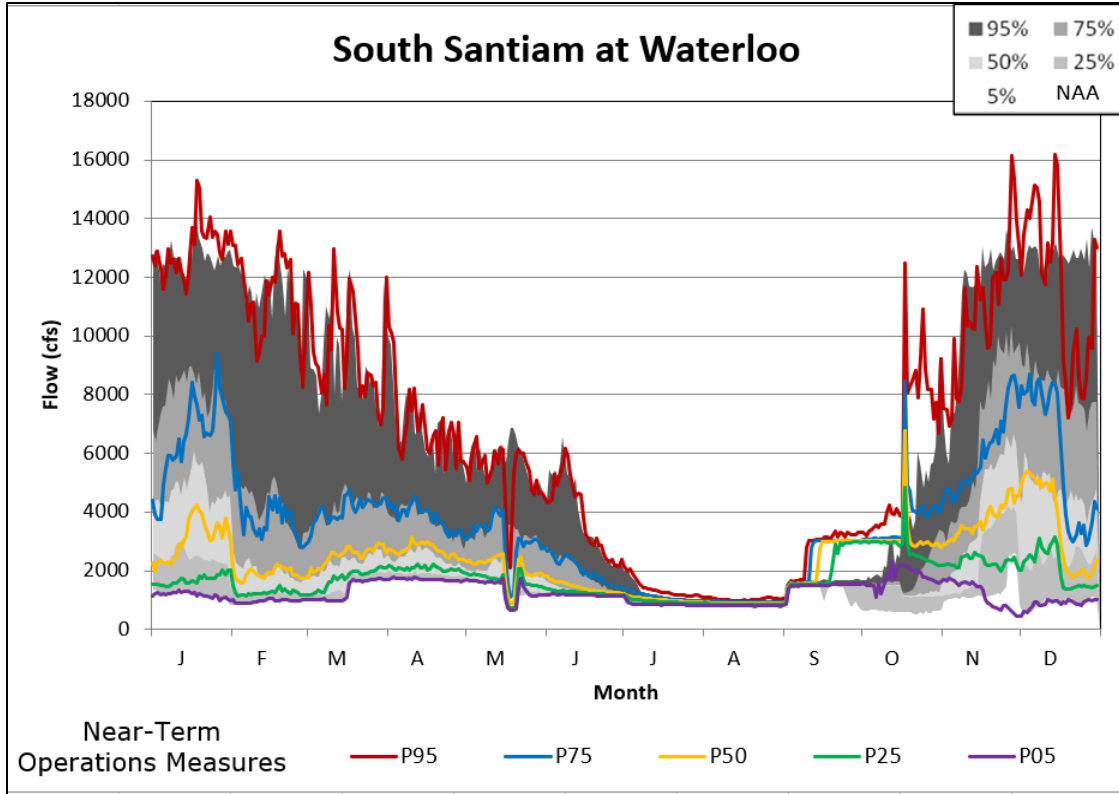

Figure 5-205. Waterloo Interim Operations Non-exceedance Plot.

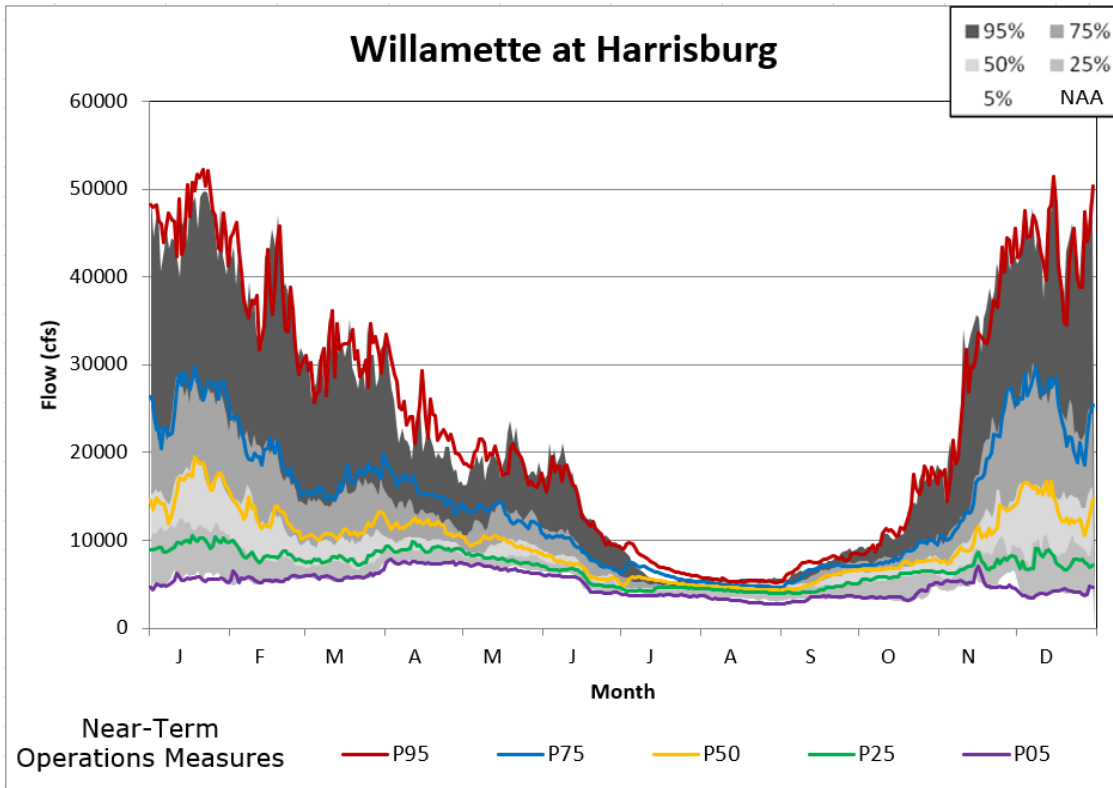

Figure 5-206. Harrisburg Interim Operations Non-exceedance Plot.

Willamette Valley System Operations and Maintenance
Environmental Impact Statement

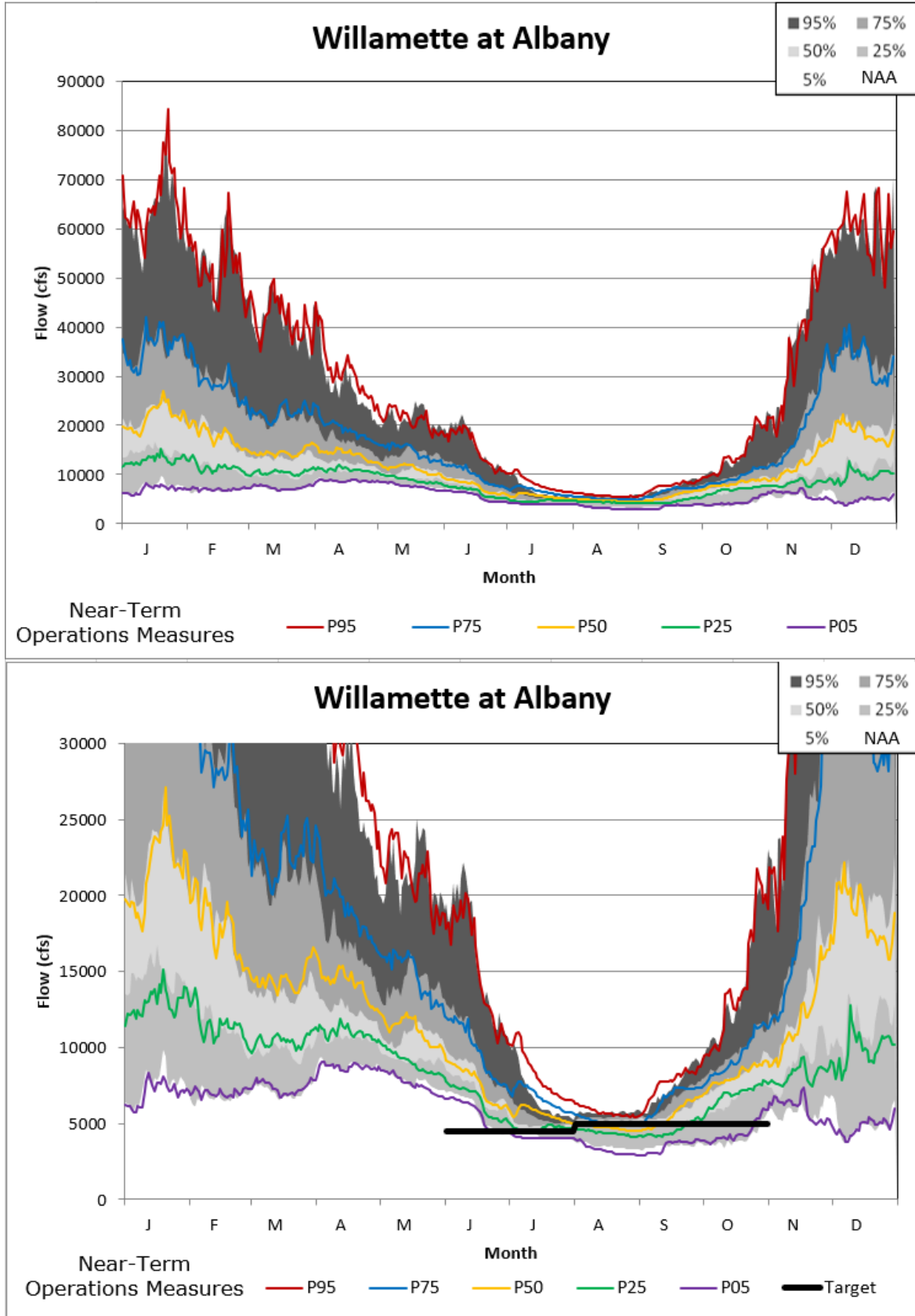

Figure 5-207. Albany Interim Operations Non-exceedance Plot.

Willamette Valley System Operations and Maintenance
Environmental Impact Statement

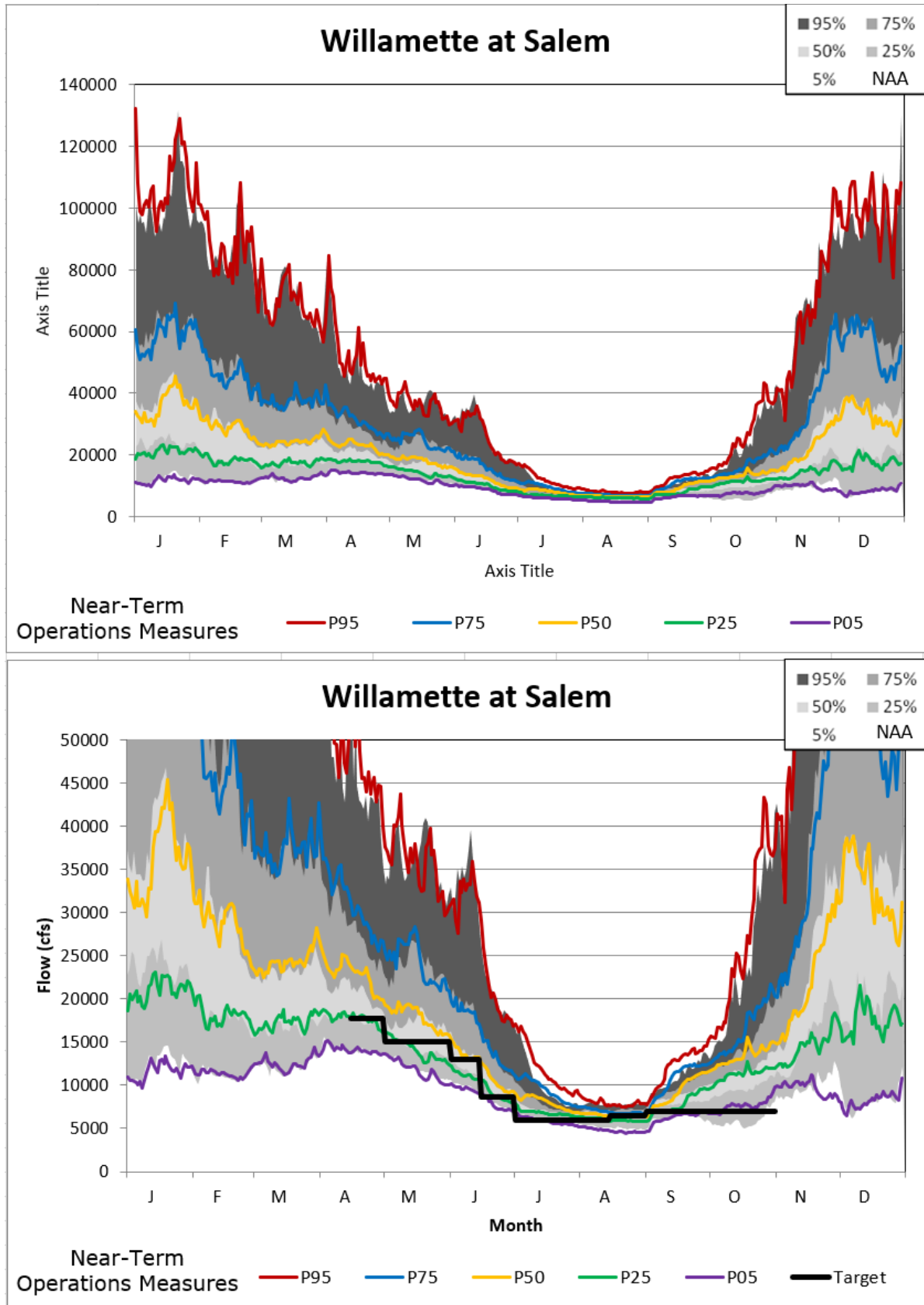
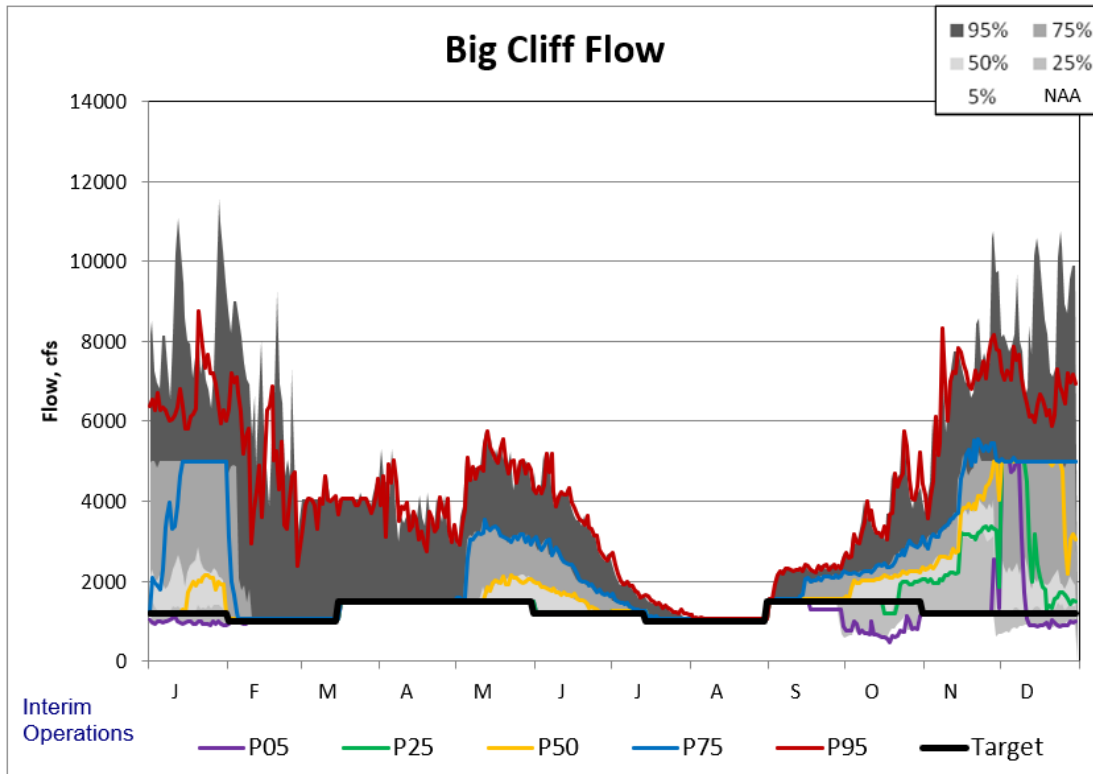

Figure 5-208. Salem Interim Operations Non-exceedance Plot.

5.10 Interim Operations

Figure 5-209. Big Cliff Updated Interim Operations Non-exceedance Plot.



Willamette Valley System Operations and Maintenance
Environmental Impact Statement

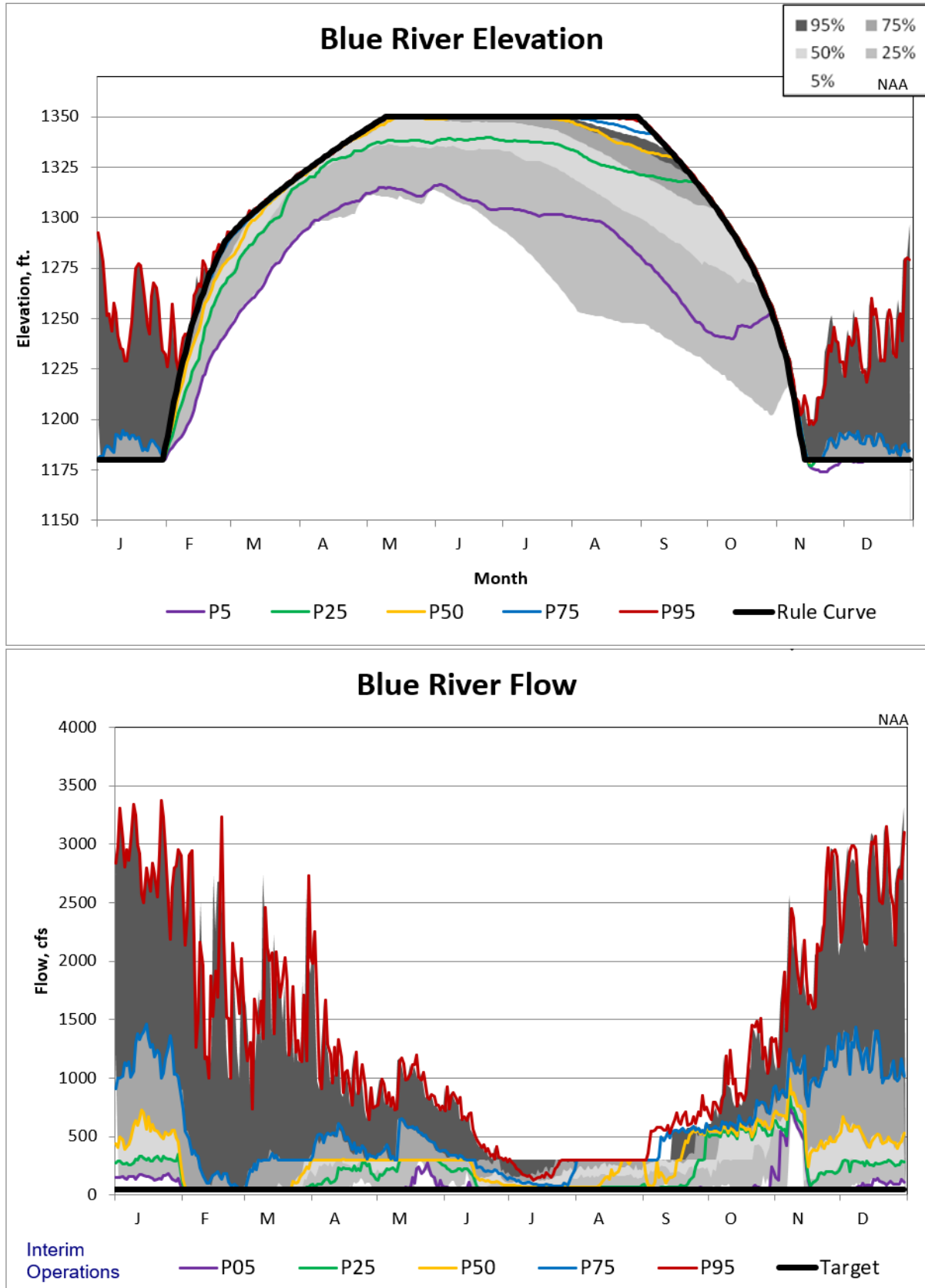

Figure 5-210. Blue River Updated Interim Operations Non-exceedance Plot.

Willamette Valley System Operations and Maintenance
Environmental Impact Statement

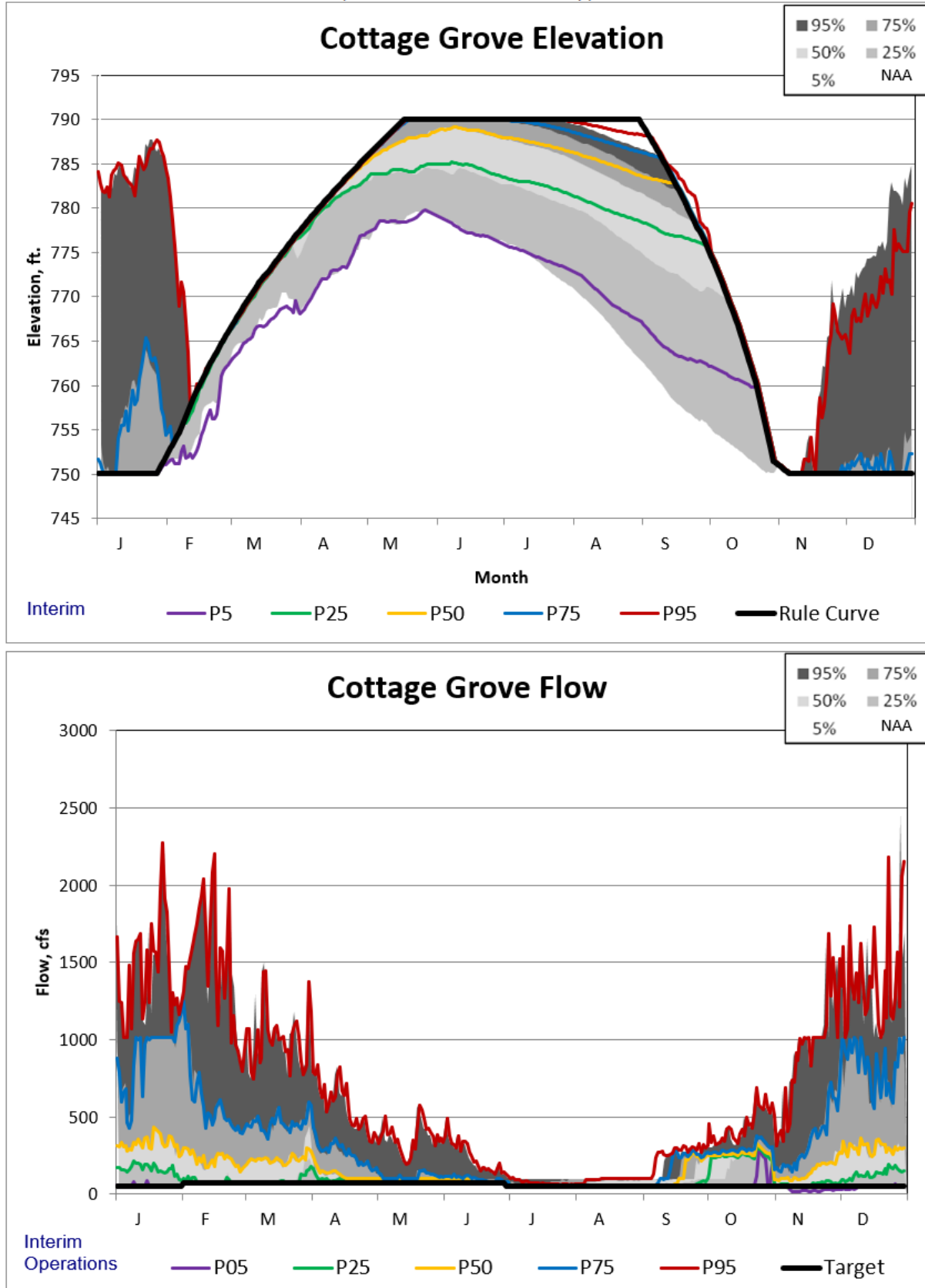

Figure 5-211. Cottage Grove Updated Interim Operations Non-exceedance Plot.

Willamette Valley System Operations and Maintenance
Environmental Impact Statement

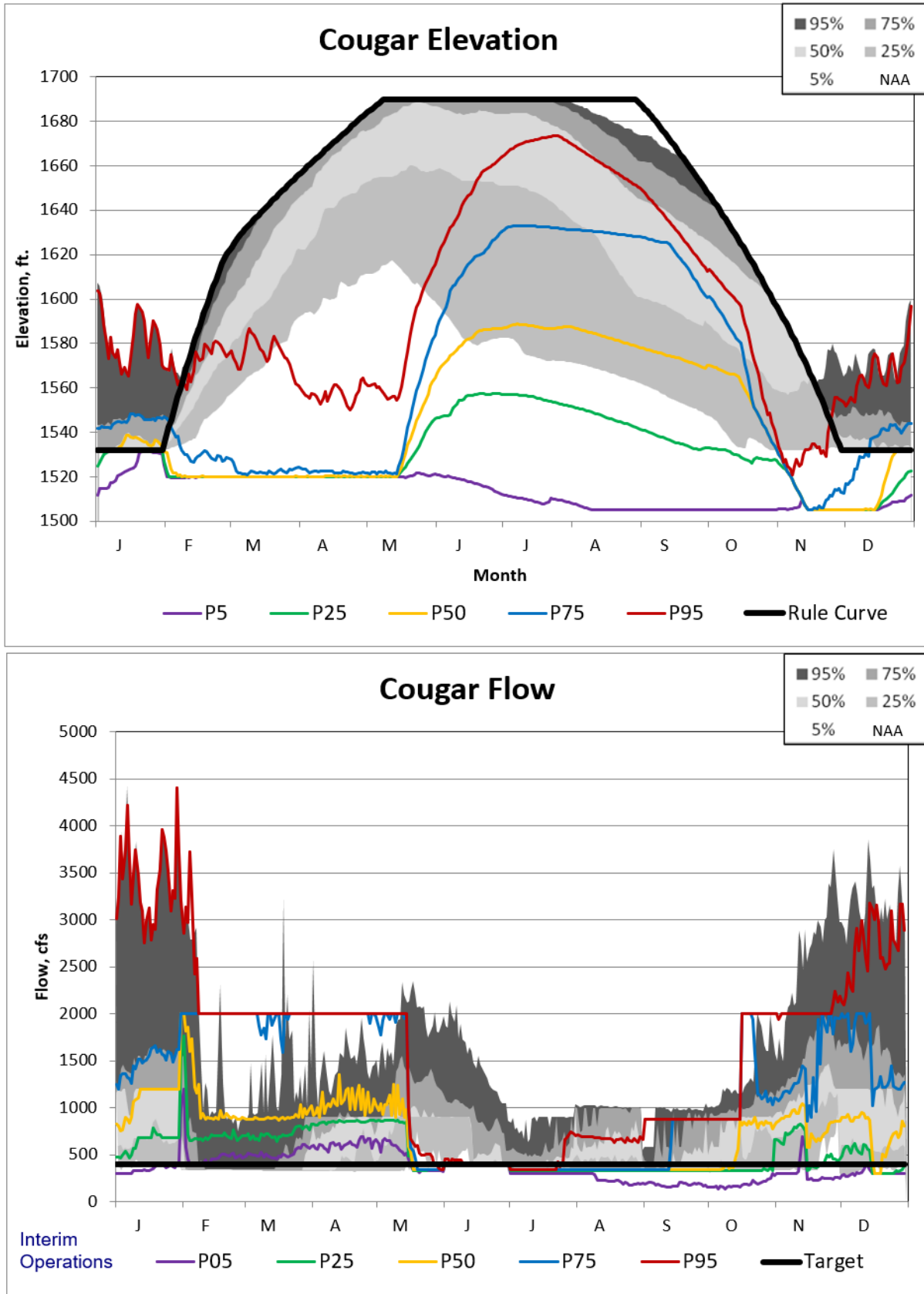

Figure 5-212. Cougar Updated Interim Operations Non-exceedance Plot.

Willamette Valley System Operations and Maintenance
Environmental Impact Statement

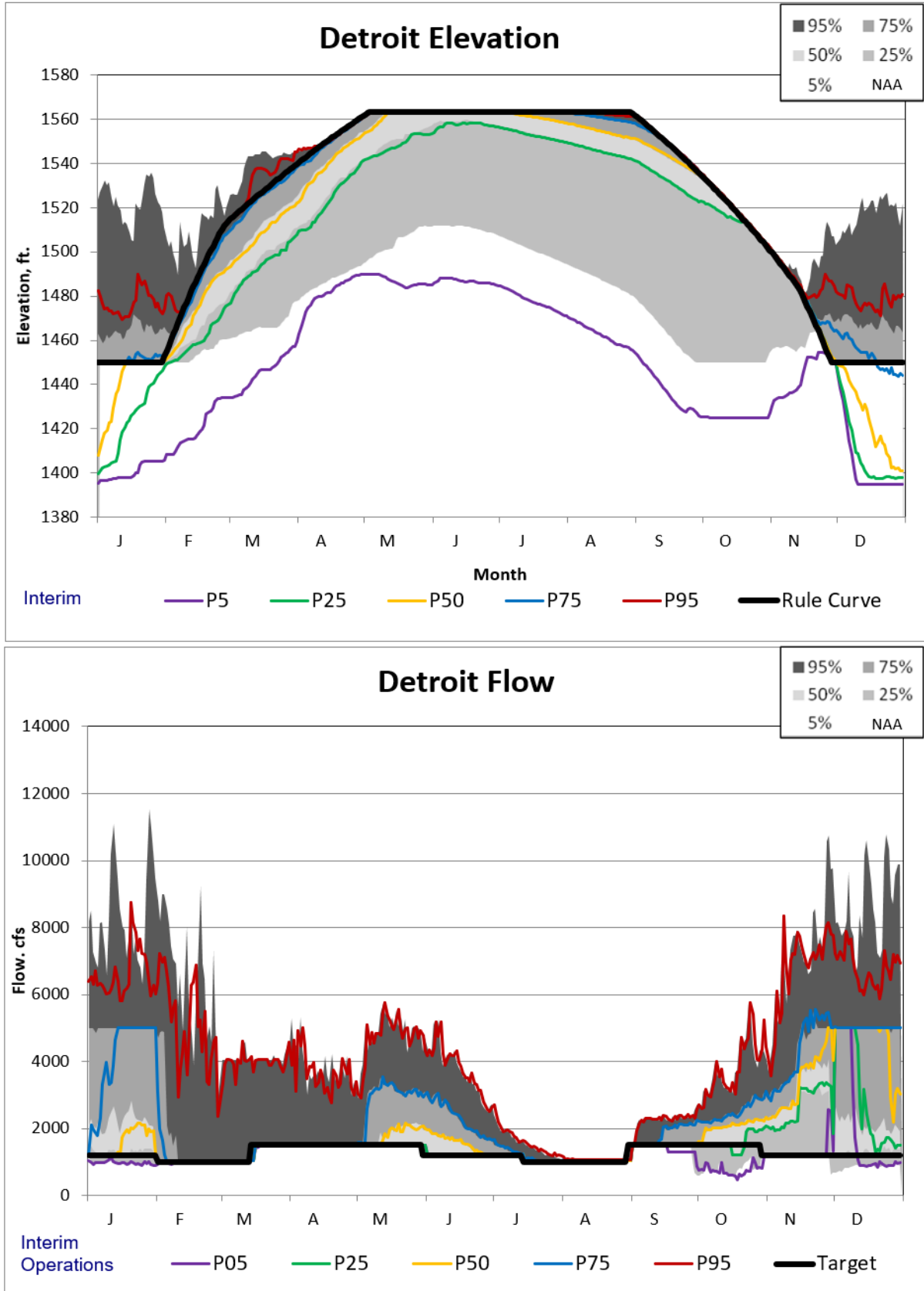

Figure 5-213. Detroit Updated Interim Operations Non-exceedance Plot.

Willamette Valley System Operations and Maintenance
Environmental Impact Statement

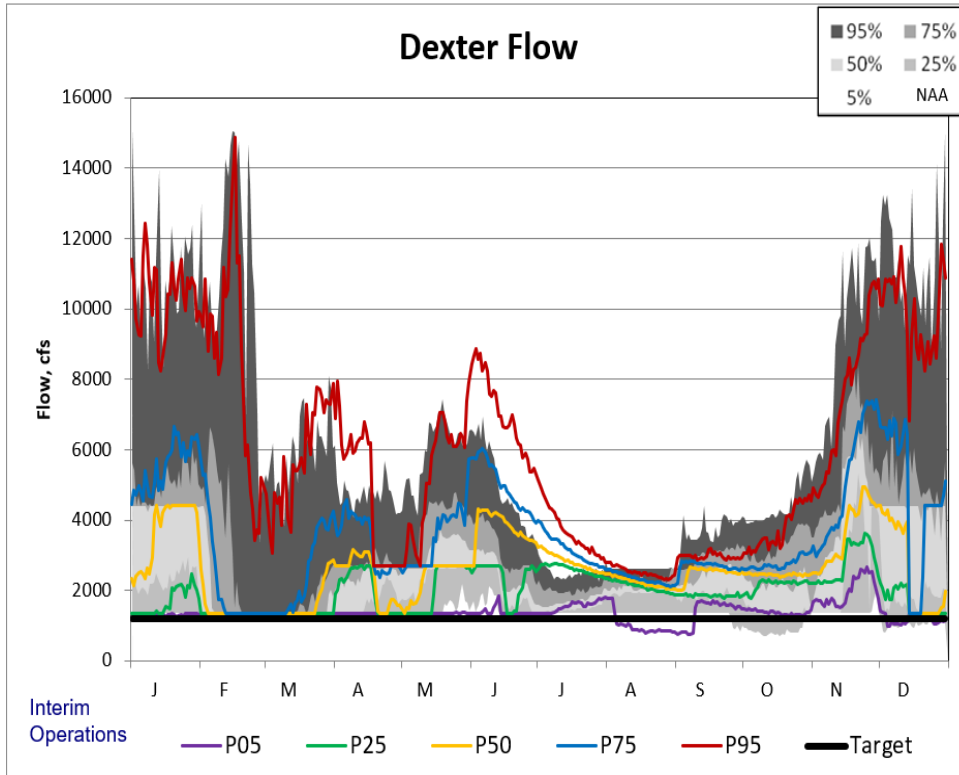

Figure 5-214. Dexter Updated Interim Operations Non-exceedance Plot.

Willamette Valley System Operations and Maintenance
Environmental Impact Statement

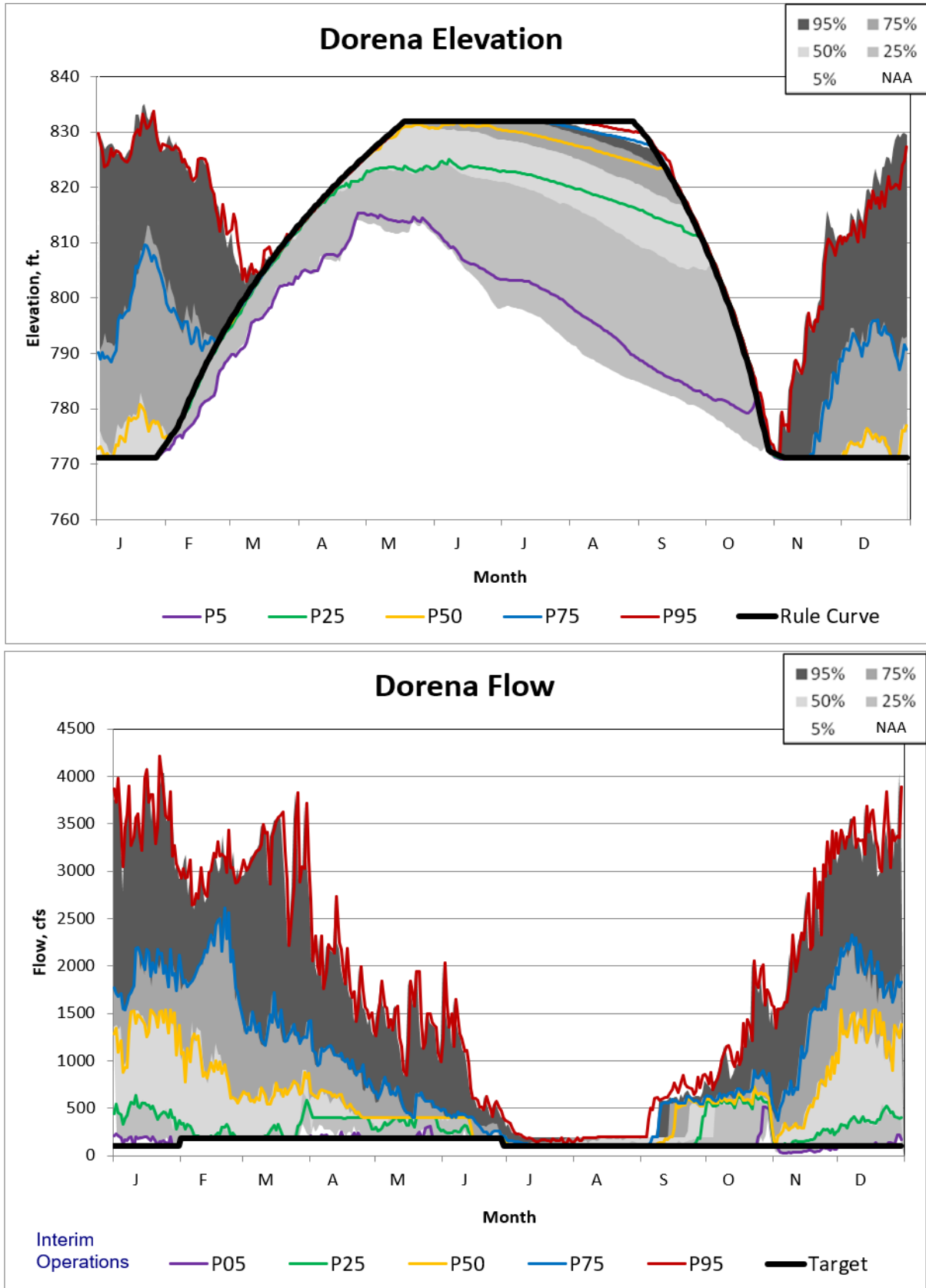

Figure 5-215. Dorena Updated Interim Operations Non-exceedance Plot.

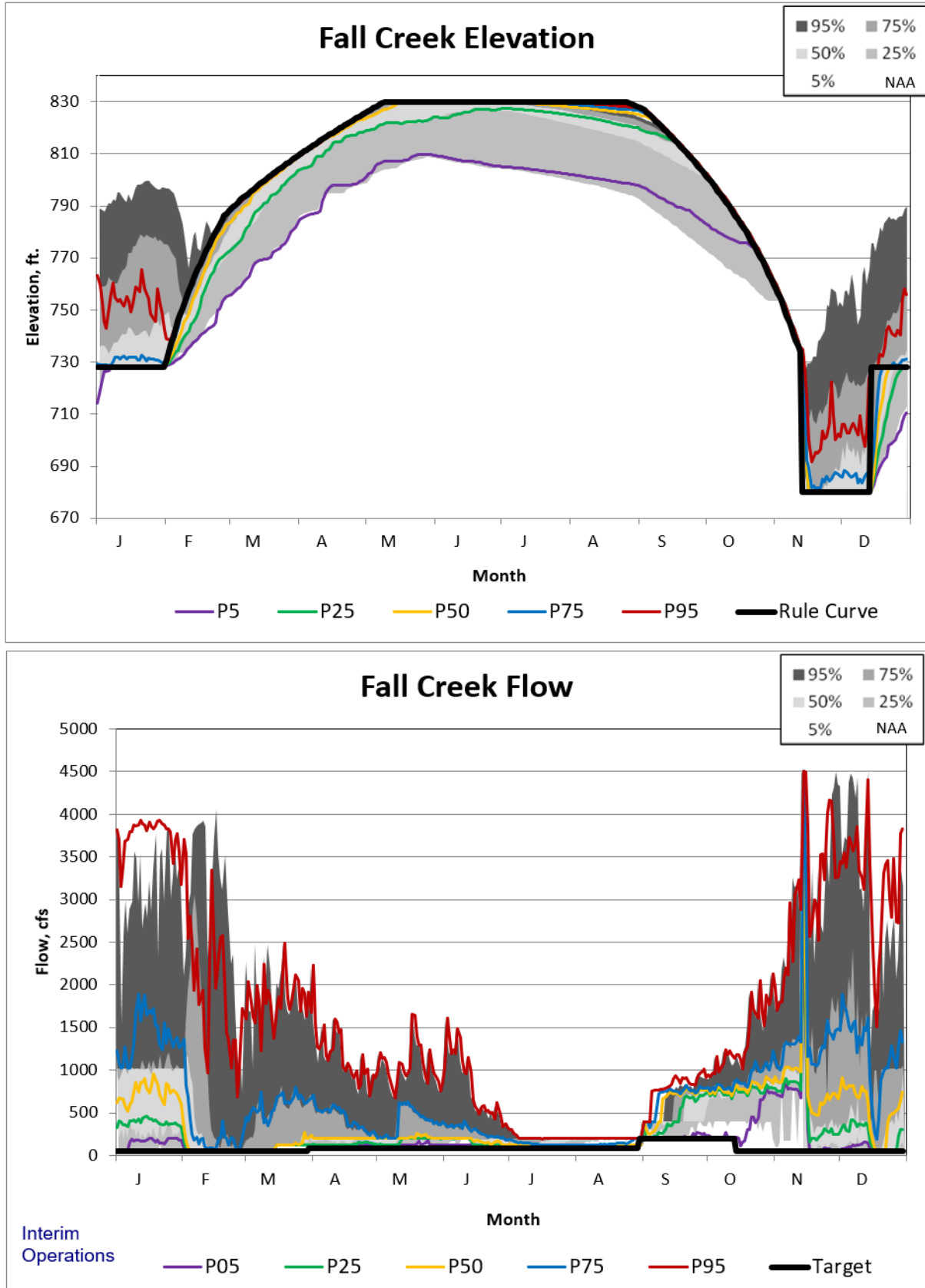

Figure 5-216. Fall Creek Updated Interim Operations Non-exceedance Plot.

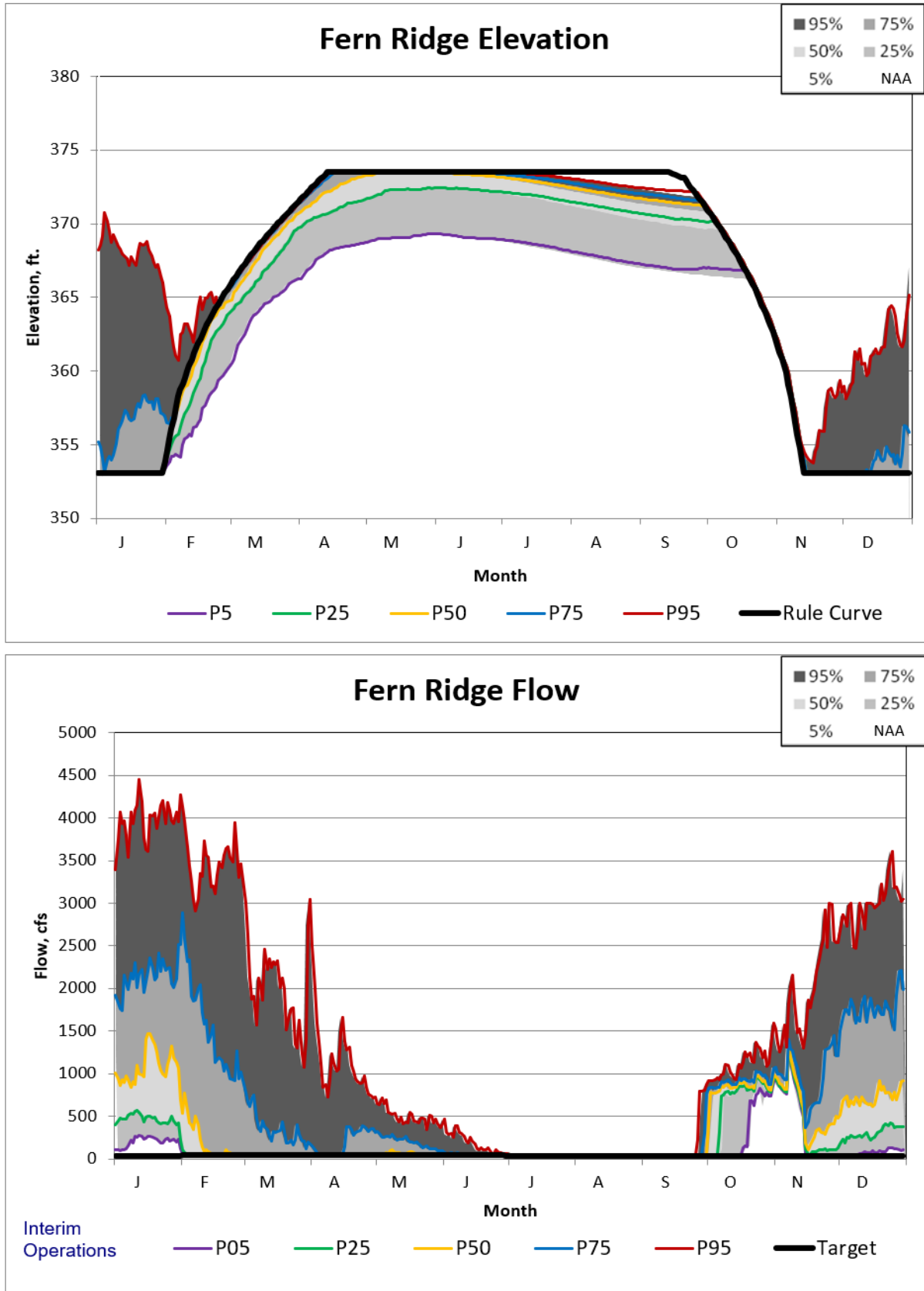

Figure 5-217. Fern Ridge Updated Interim Operations Non-exceedance Plot.

Willamette Valley System Operations and Maintenance
Environmental Impact Statement

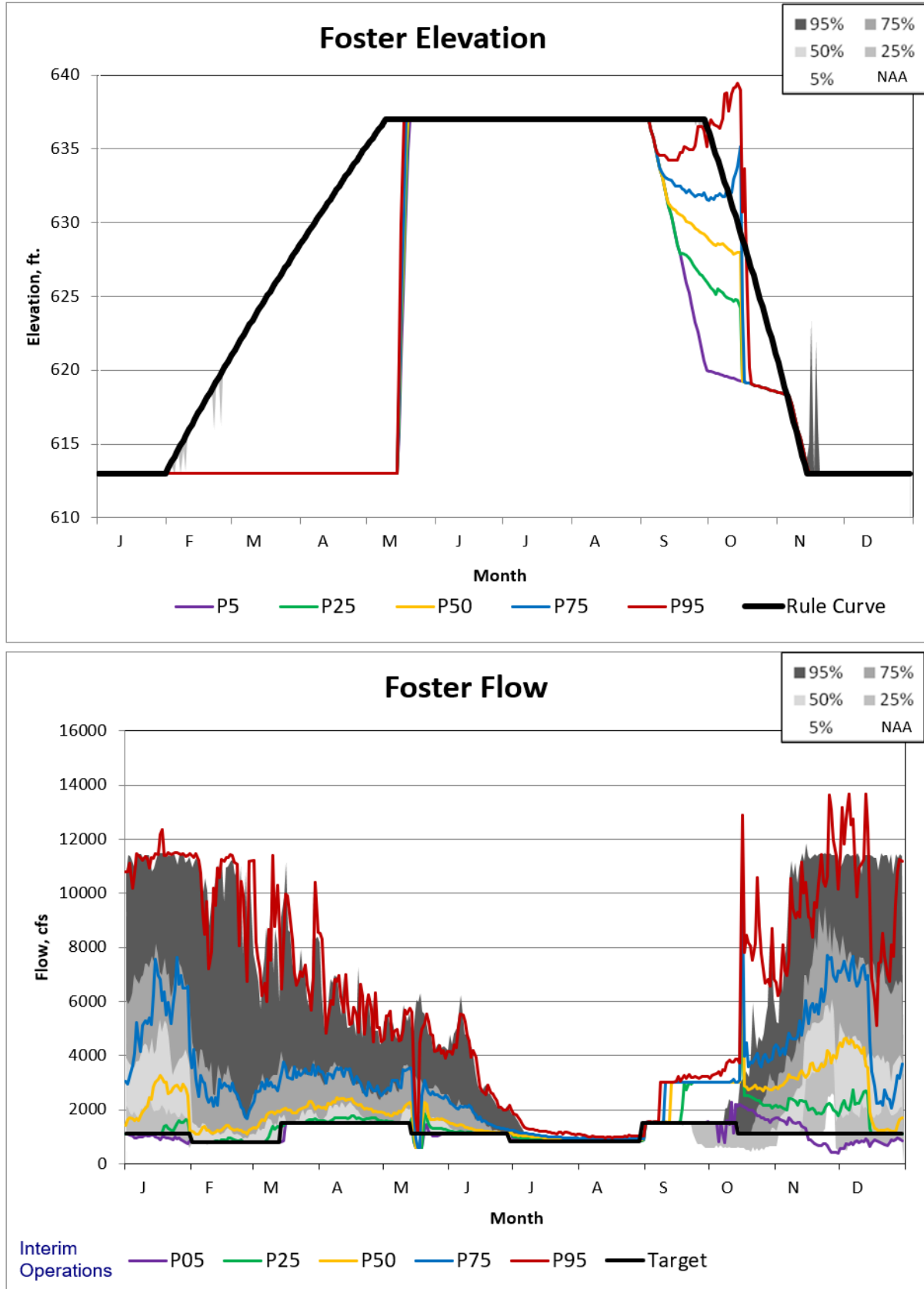

Figure 5-218. Foster Updated Interim Operations Non-exceedance Plot.

Willamette Valley System Operations and Maintenance
Environmental Impact Statement

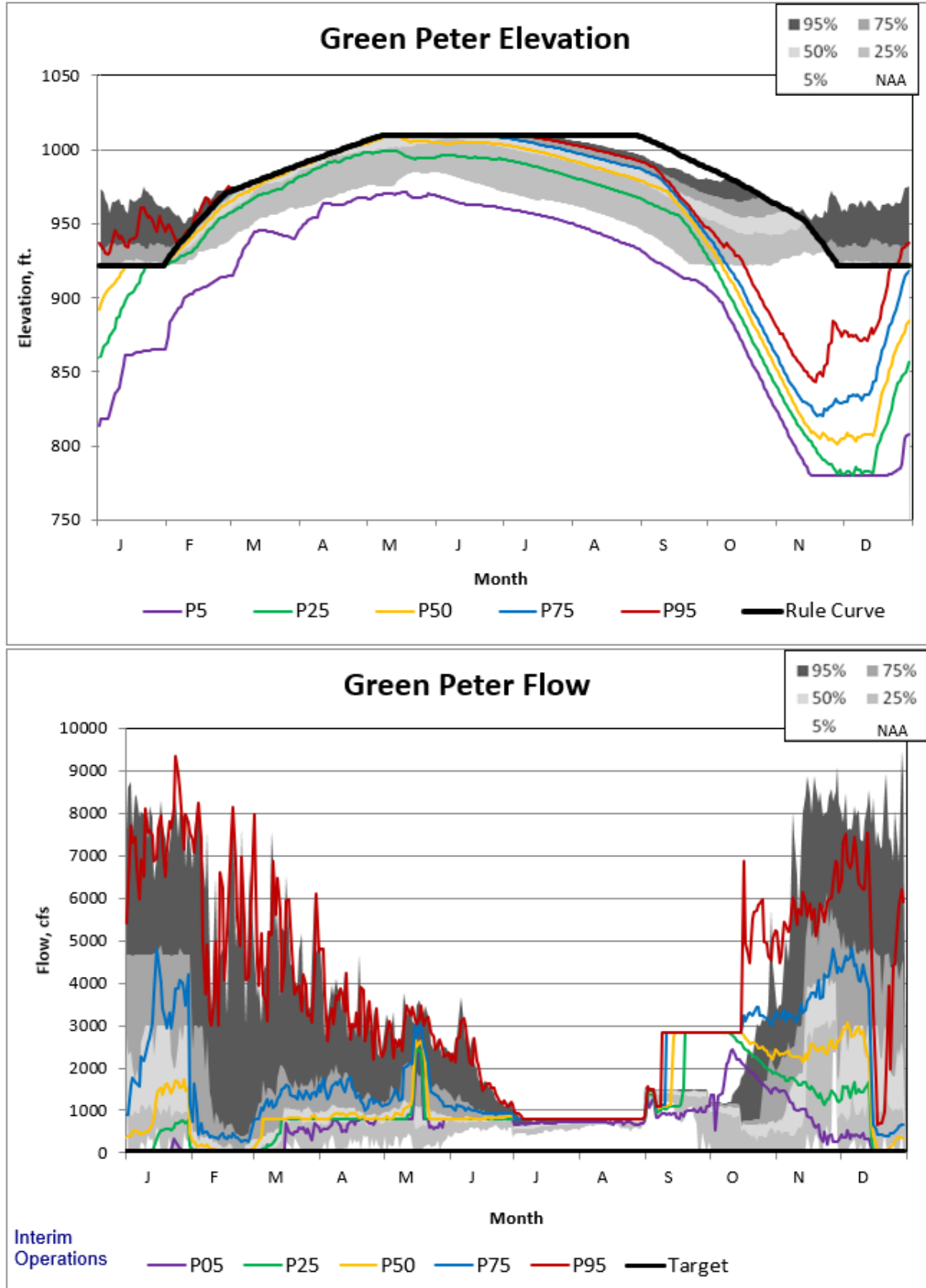

Figure 5-219. Green Peter Updated Interim Operations Non-exceedance Plot.

Willamette Valley System Operations and Maintenance
Environmental Impact Statement

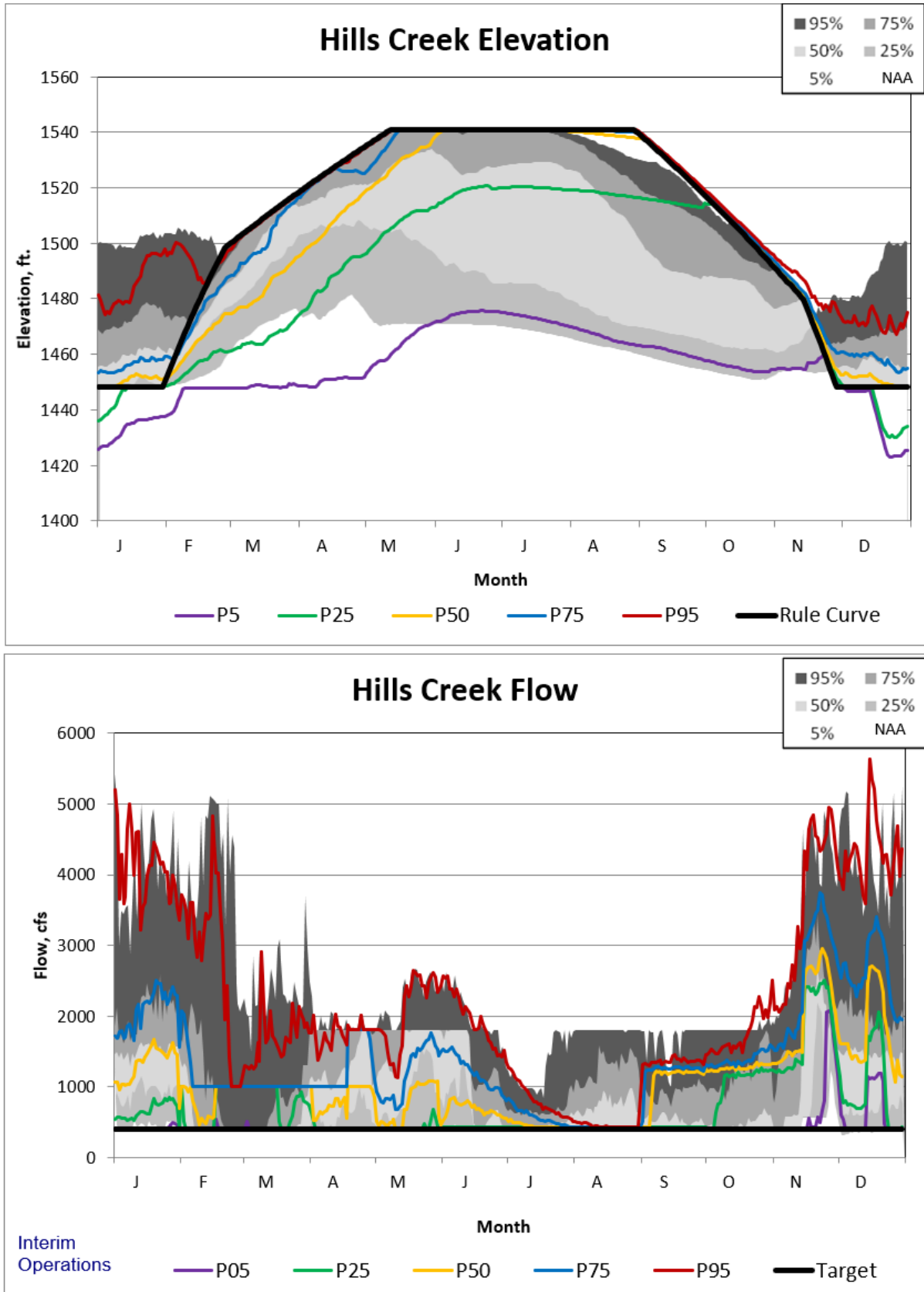

Figure 5-220. Hills Creek Updated Interim Operations Non-exceedance Plot.

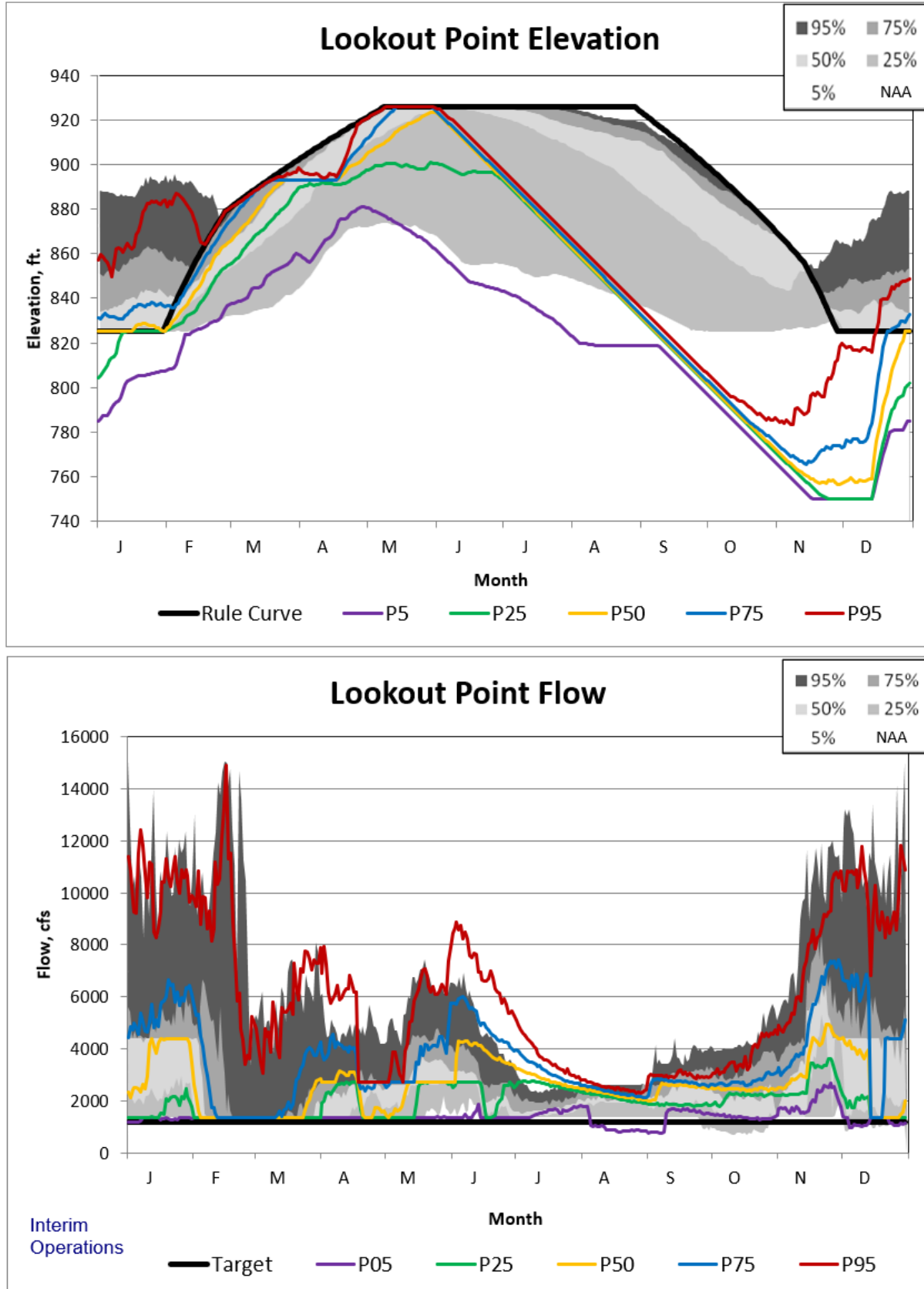

Figure 5-221. Lookout Point Updated Interim Operations Non-exceedance Plot.

Willamette Valley System Operations and Maintenance
Environmental Impact Statement

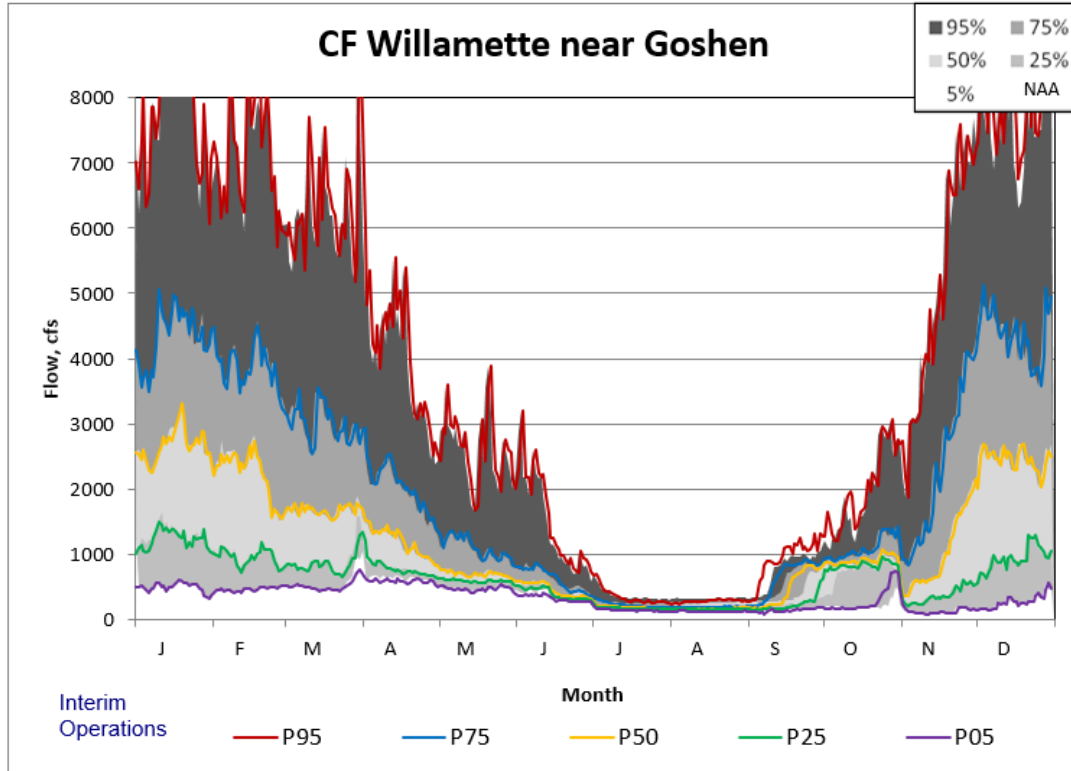

Figure 5-222. Goshen Updated Interim Operations Non-exceedance Plot.

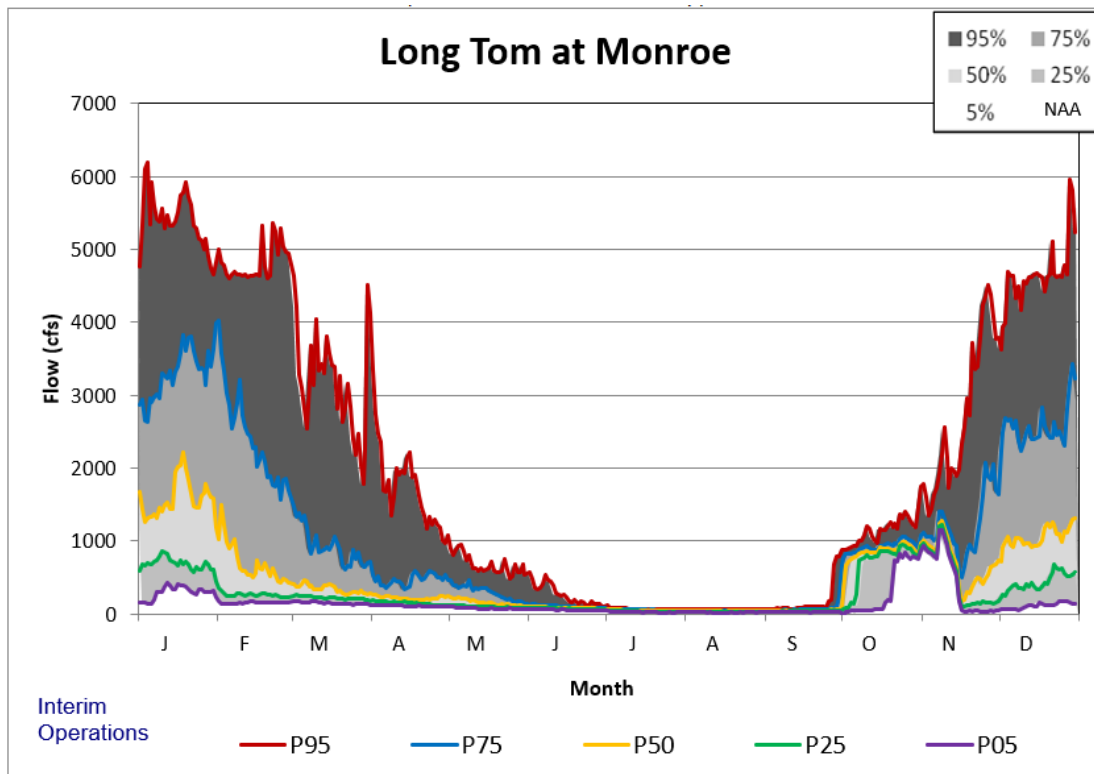

Figure 5-223. Monroe Updated Interim Operations Non-exceedance Plot.

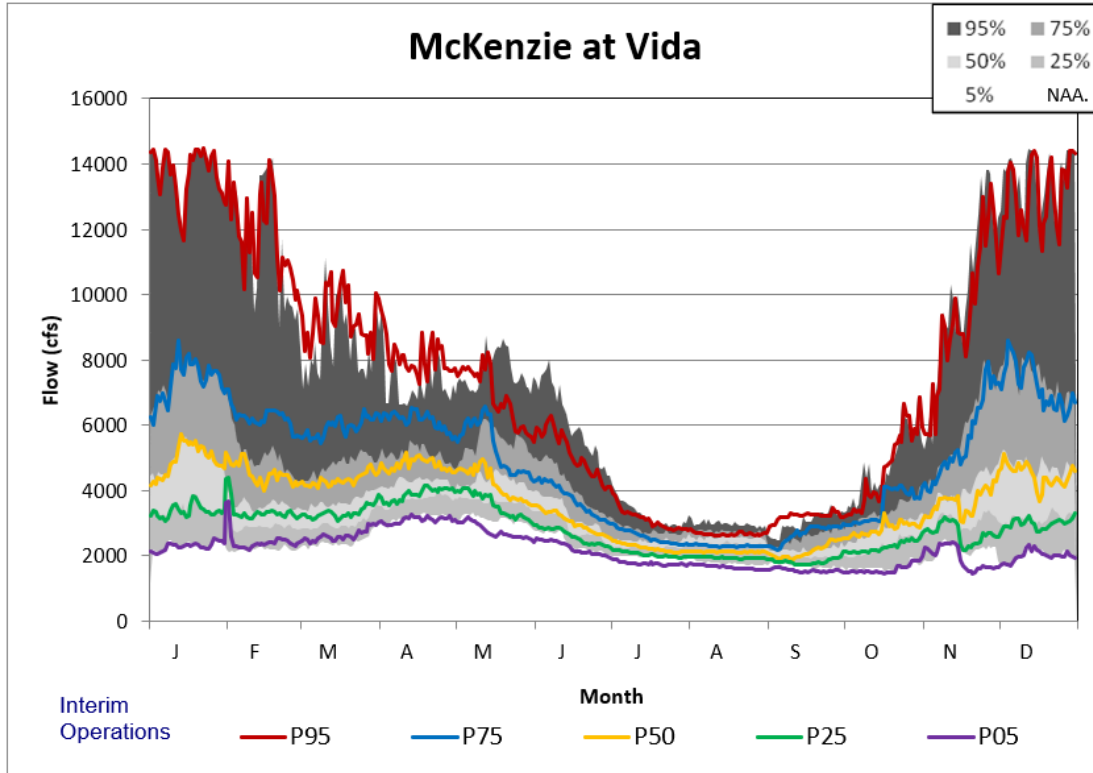

Figure 5-224. Vida Updated Interim Operations Non-exceedance Plot.

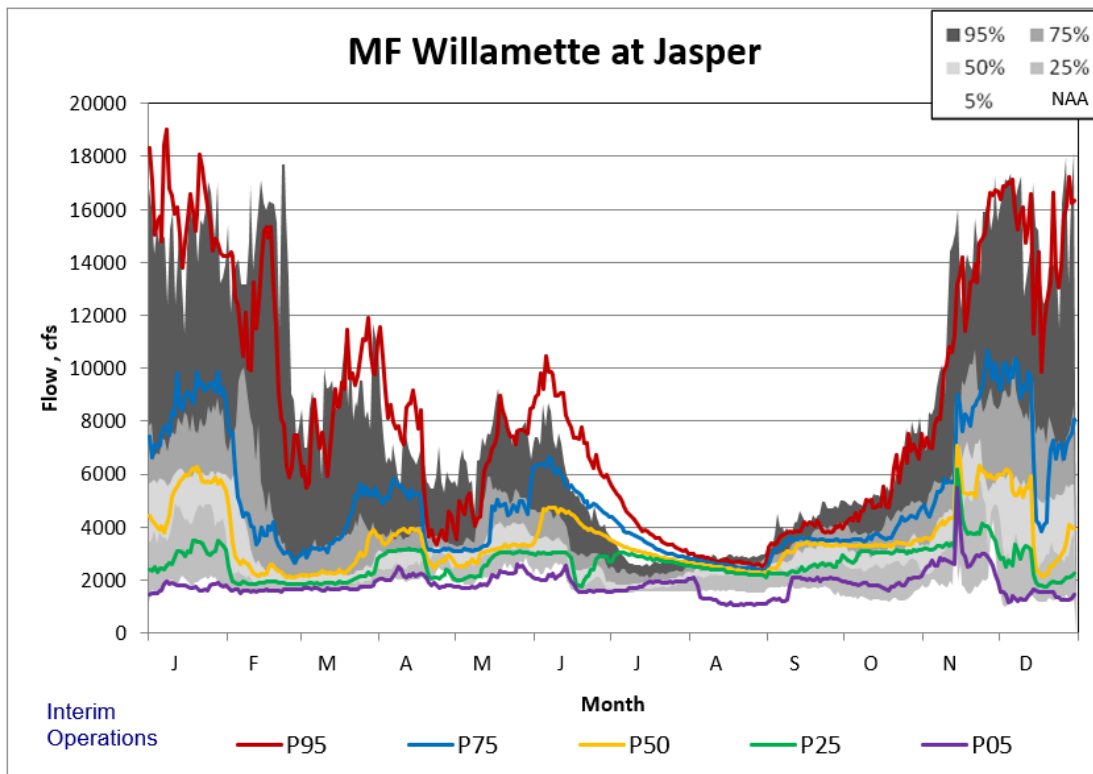

Figure 5-225. Jasper Updated Interim Operations Non-exceedance Plot.

*Willamette Valley System Operations and Maintenance
Environmental Impact Statement*

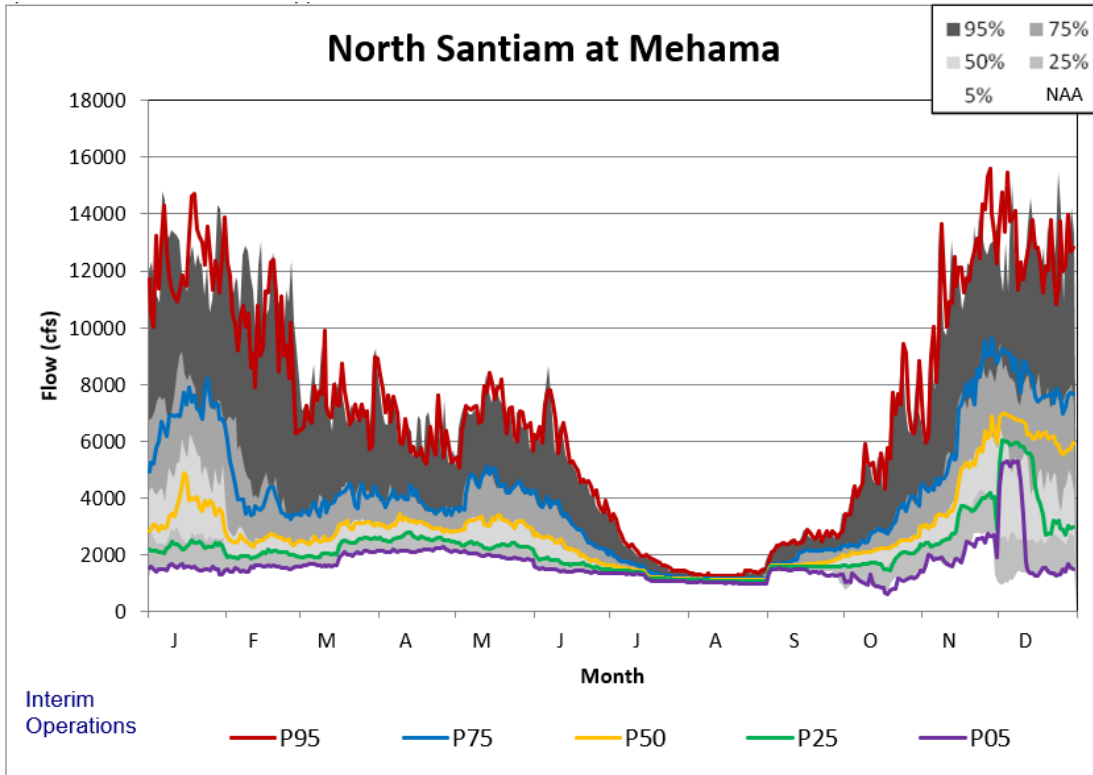

Figure 5-226. Mehama Updated Interim Operations Non-exceedance Plot.

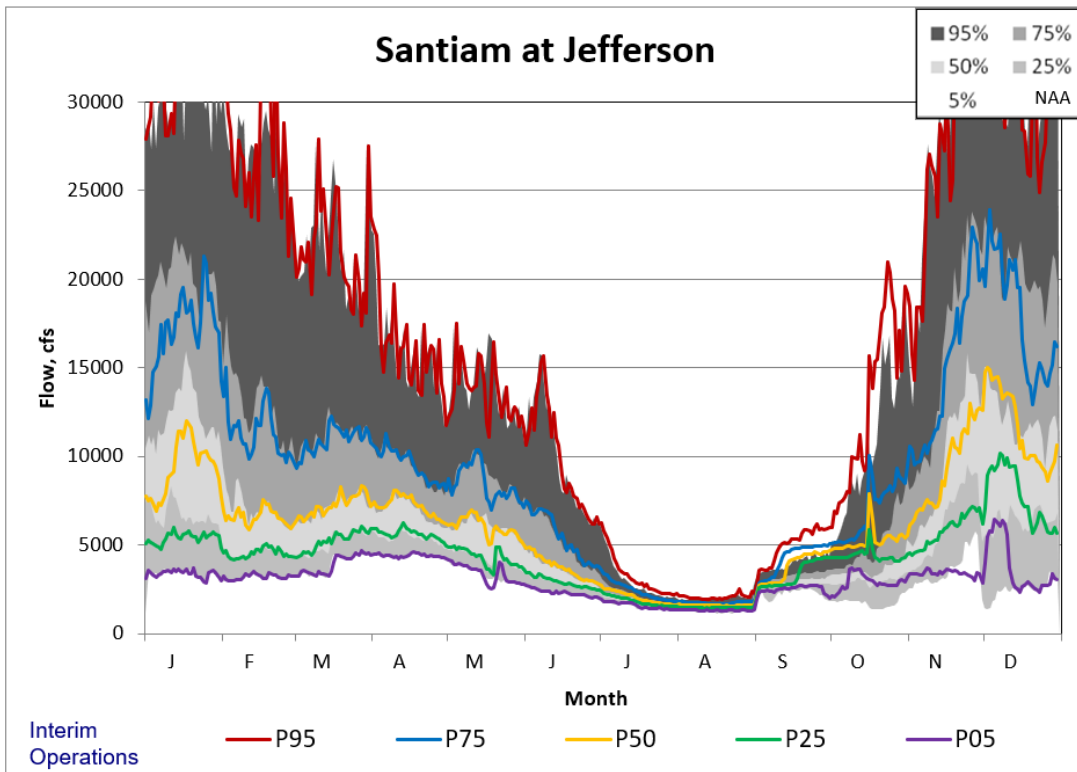

Figure 5-227. Jefferson Updated Interim Operations Non-exceedance Plot.

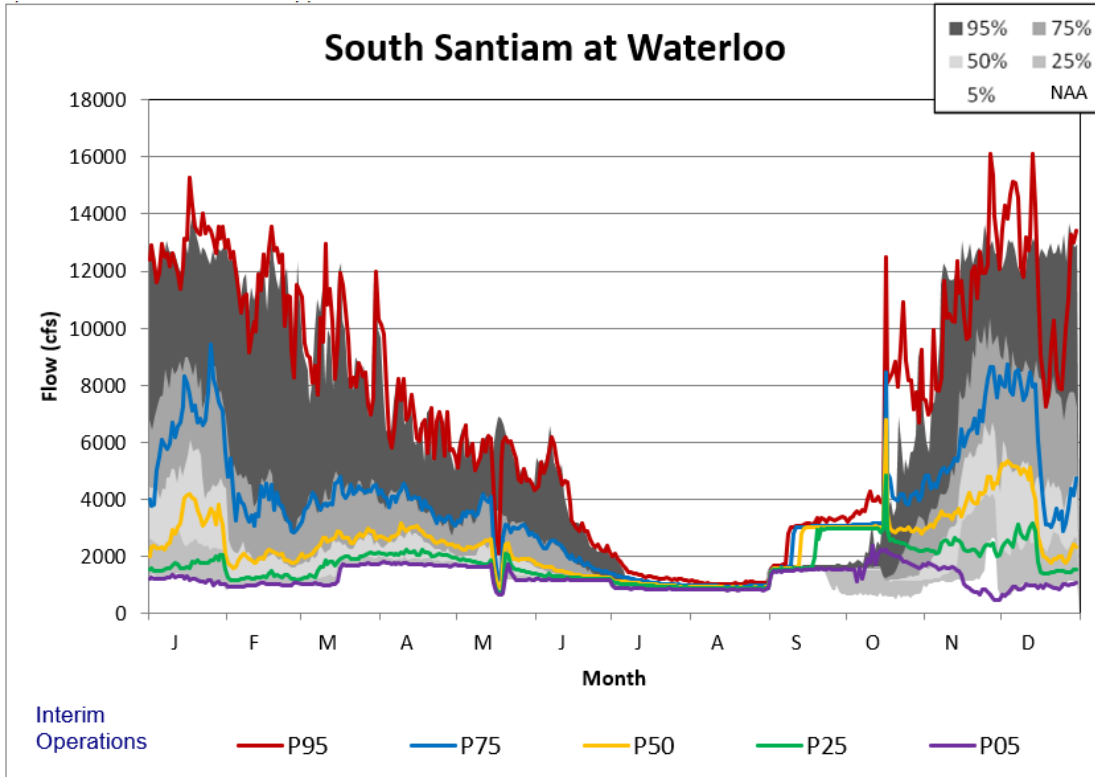

Figure 5-228. Waterloo Updated Interim Operations Non-exceedance Plot.

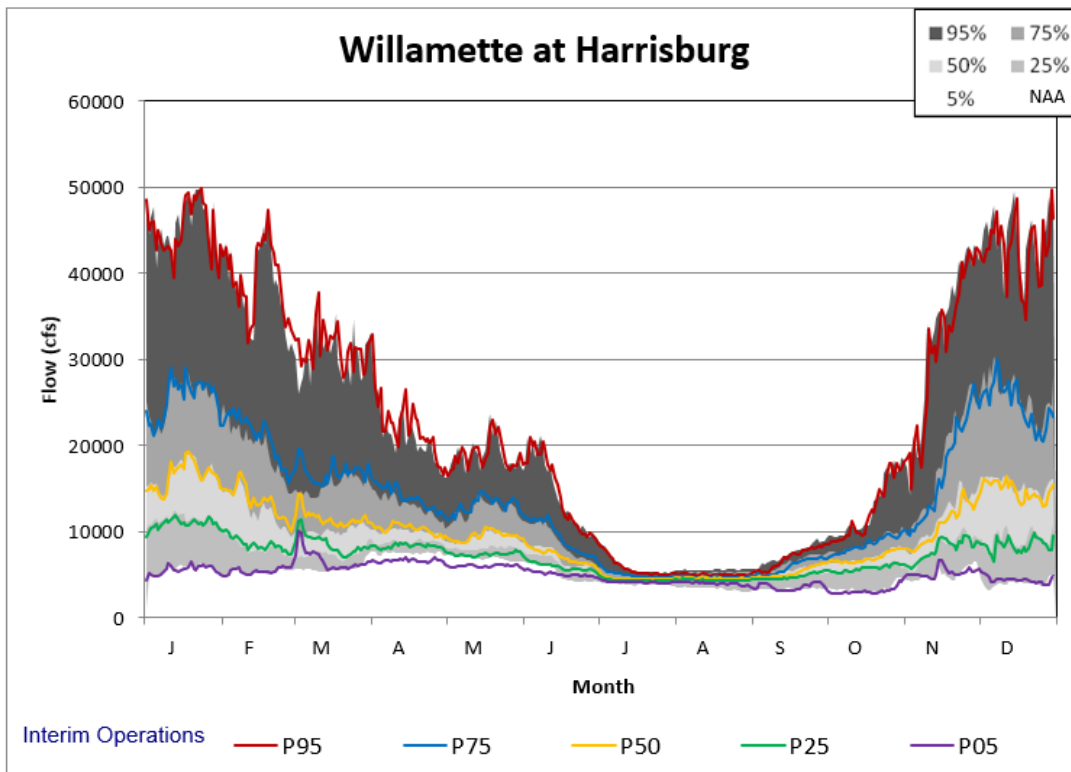

Figure 5-229. Harrisburg Updated Interim Operations Non-exceedance Plot.

Willamette Valley System Operations and Maintenance
Environmental Impact Statement

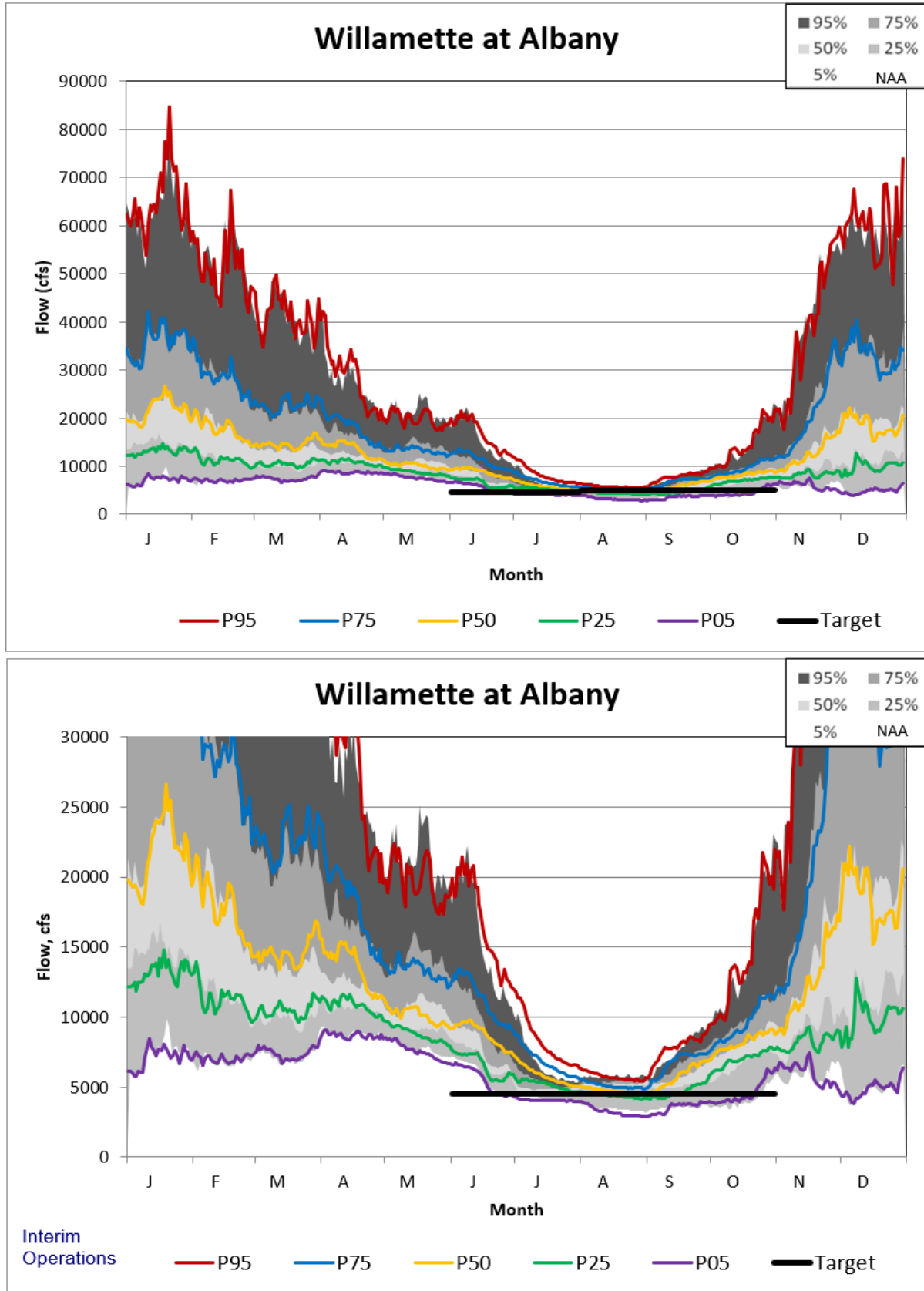

Figure 5-230. Albany Updated Interim Operations Non-exceedance Plot.

Willamette Valley System Operations and Maintenance
Environmental Impact Statement

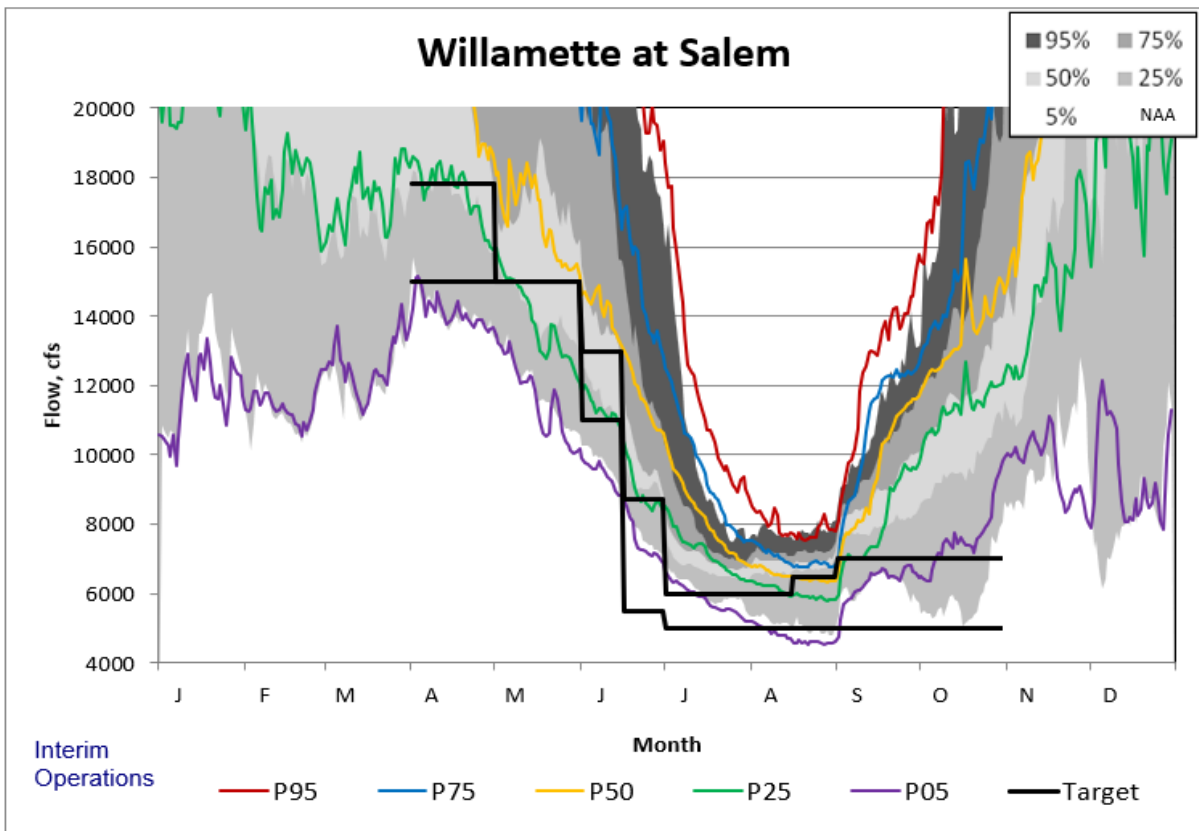
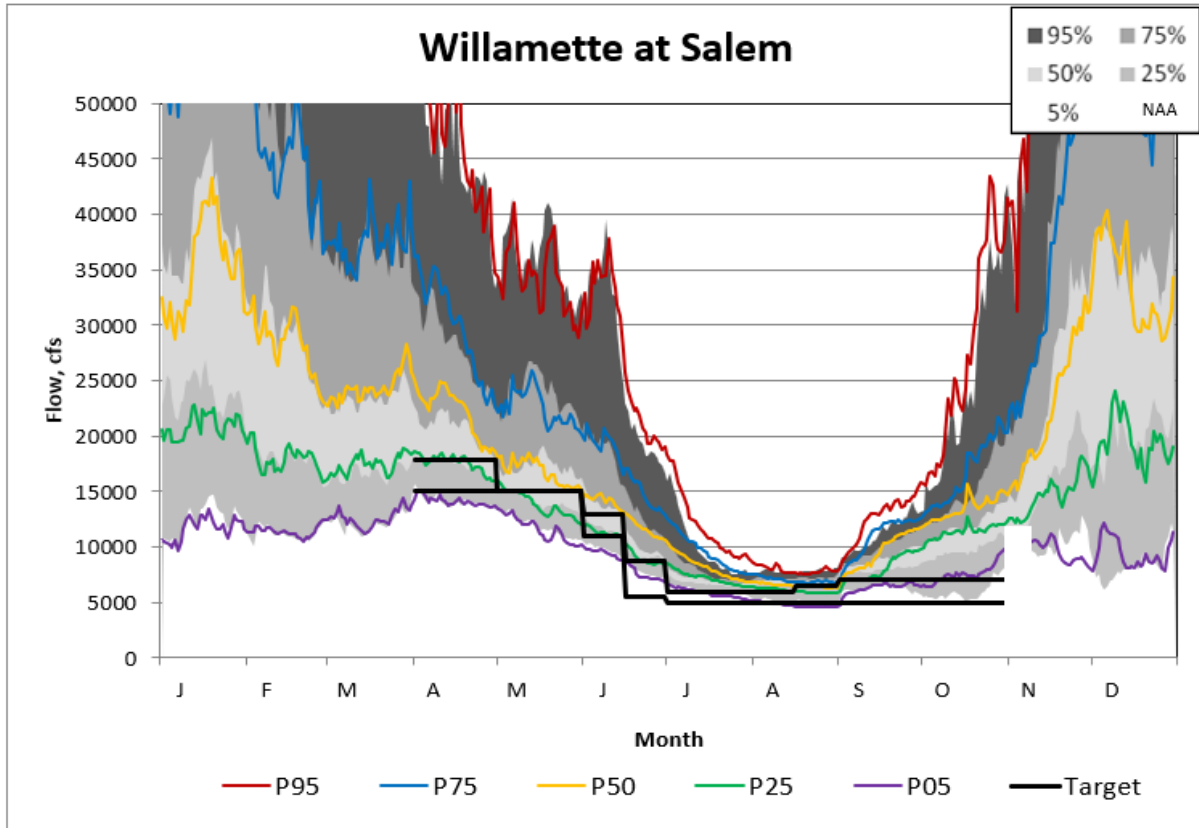

Figure 5-231. Salem Updated Interim Operations Non-exceedance Plot.

5.11 Alternative 5 / Alternative 2B Comparison Plots

Modeled measures in Alternative 5 are identical to Alternative 2B except for the minimum mainstem flows at Salem, minimum tributary flows below Foster Dam and Reservoir, and the allowable drawdown rate at Cougar Dam and Reservoir. This section shows non-exceedance plots where the shaded non-exceedance percentiles are results from Alternative 2B and the colored lines show results from Alternative 5, and annual results comparing Alternatives 5 and 2B for the years 2011, 2015, and 2016.

5.12 Alternative 5/Alternative 2B Non-exceedance Plots

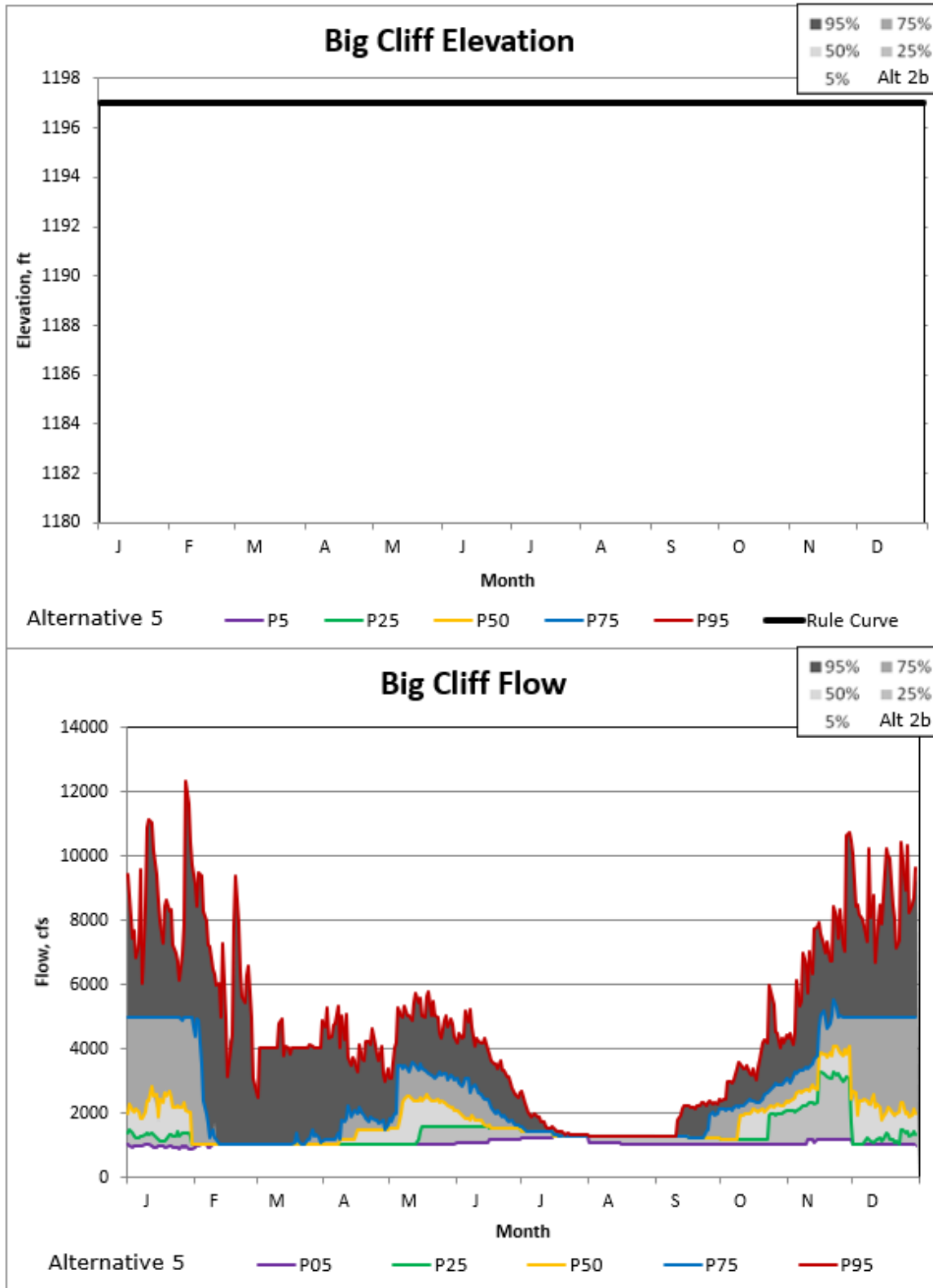

Figure 5-232. Big Cliff Alternatives 5/2B Non-exceedance Plot.

Willamette Valley System Operations and Maintenance
Environmental Impact Statement

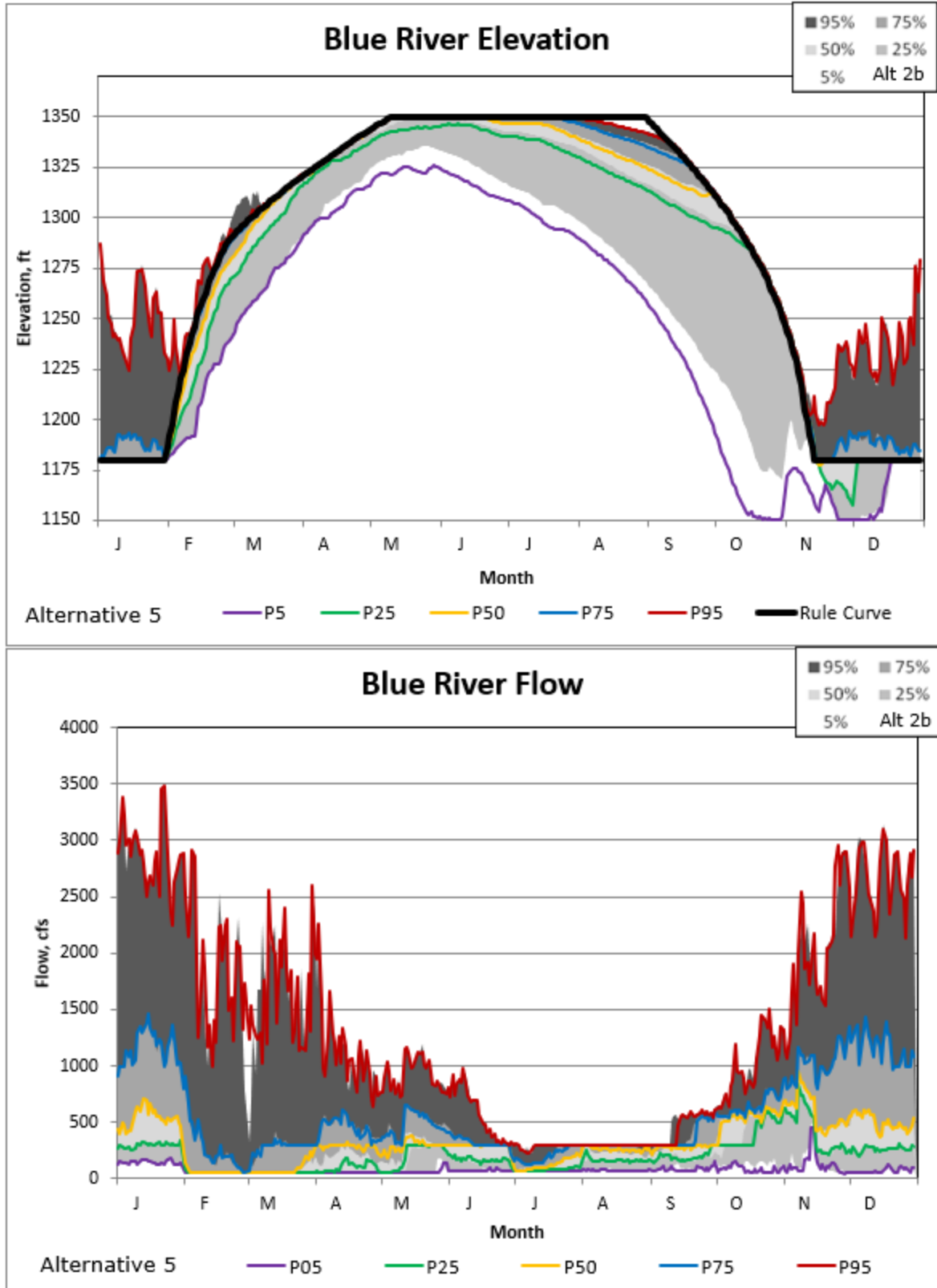

Figure 5-233. Blue River Alternatives 5/2B Non-exceedance Plot.

Willamette Valley System Operations and Maintenance
Environmental Impact Statement

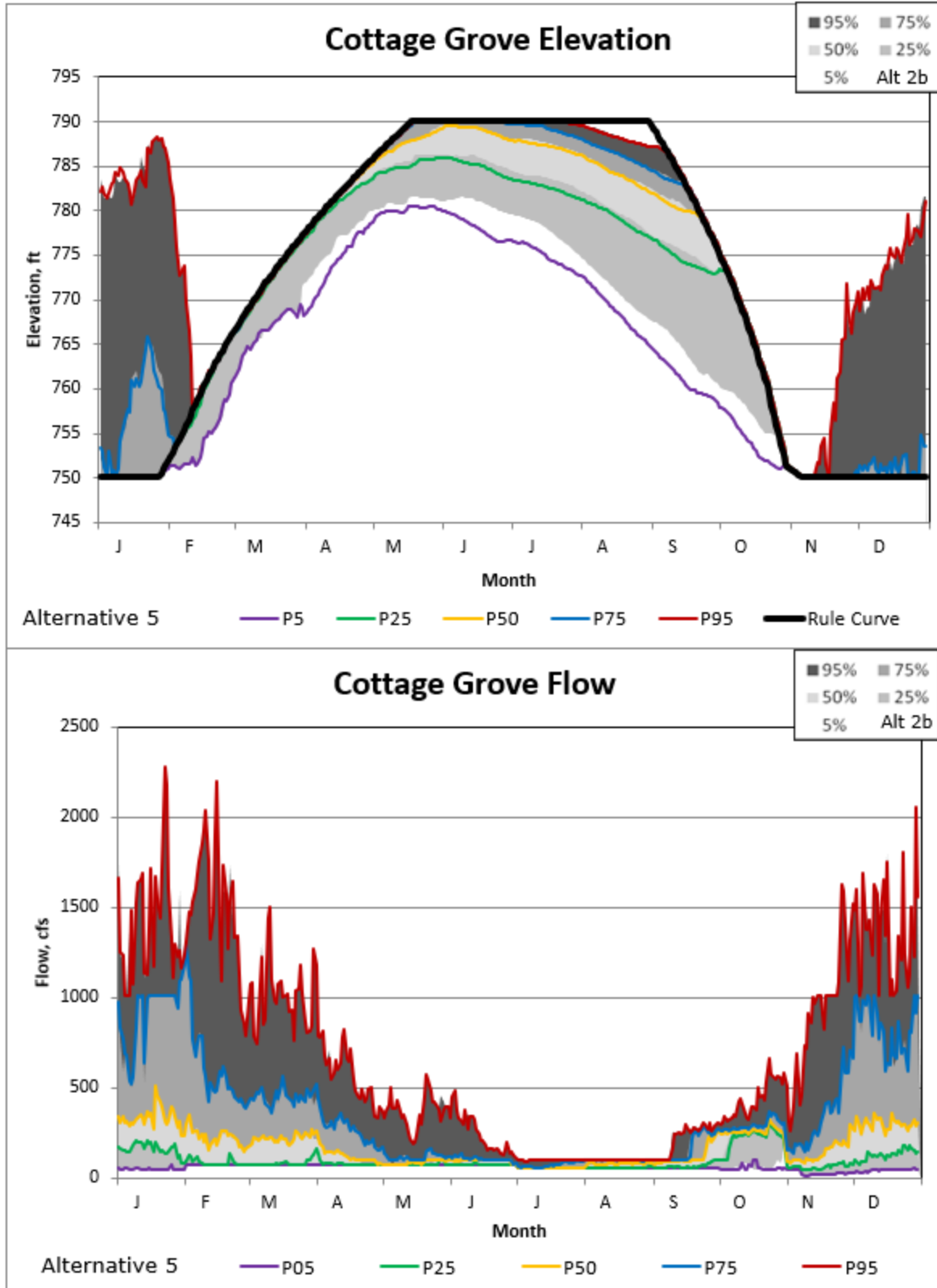

Figure 5-234. Cottage Grove Alternatives 5/2B Non-exceedance Plot.

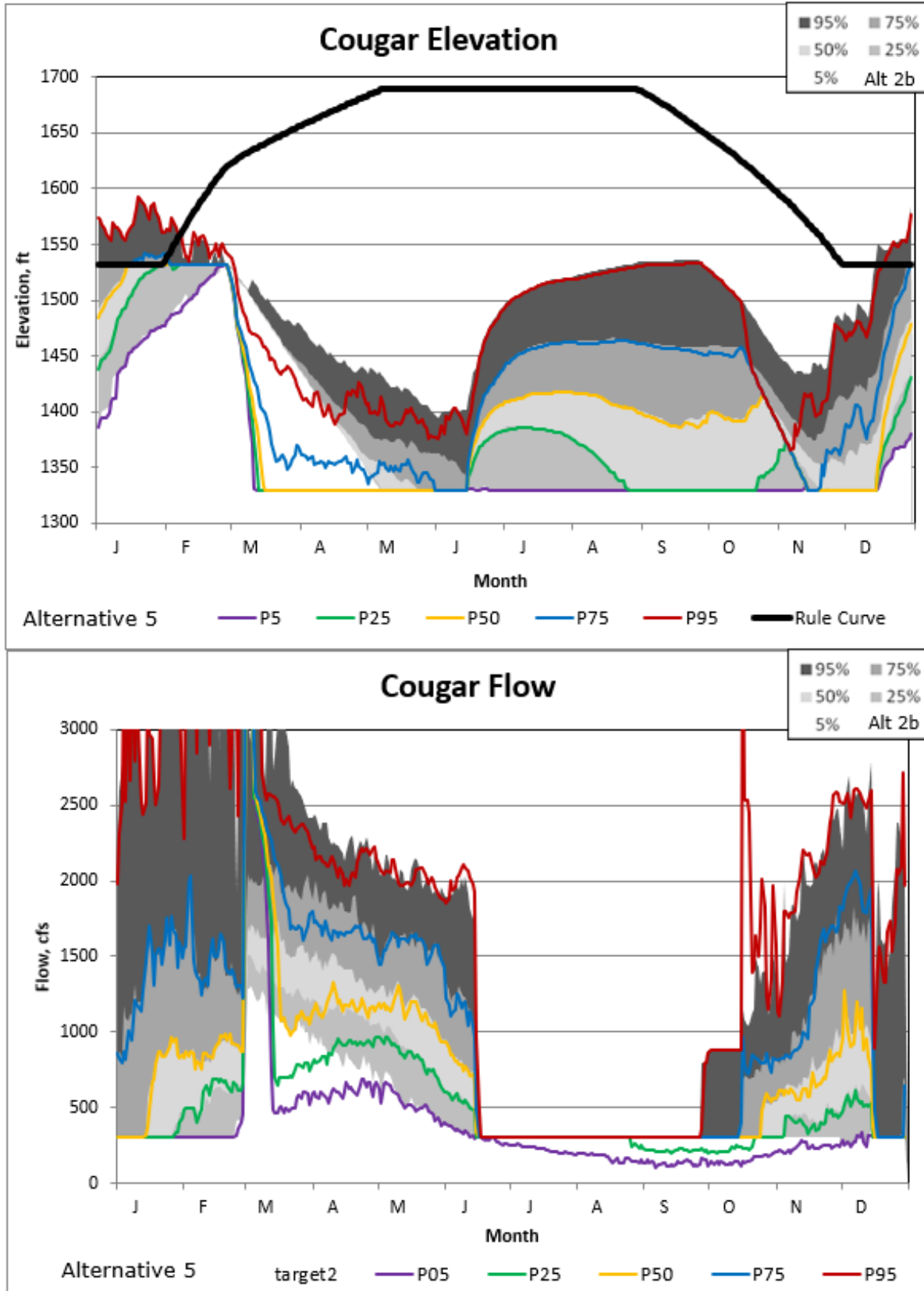

Figure 5-235. Cougar Alternatives 5/2B Non-exceedance Plot.

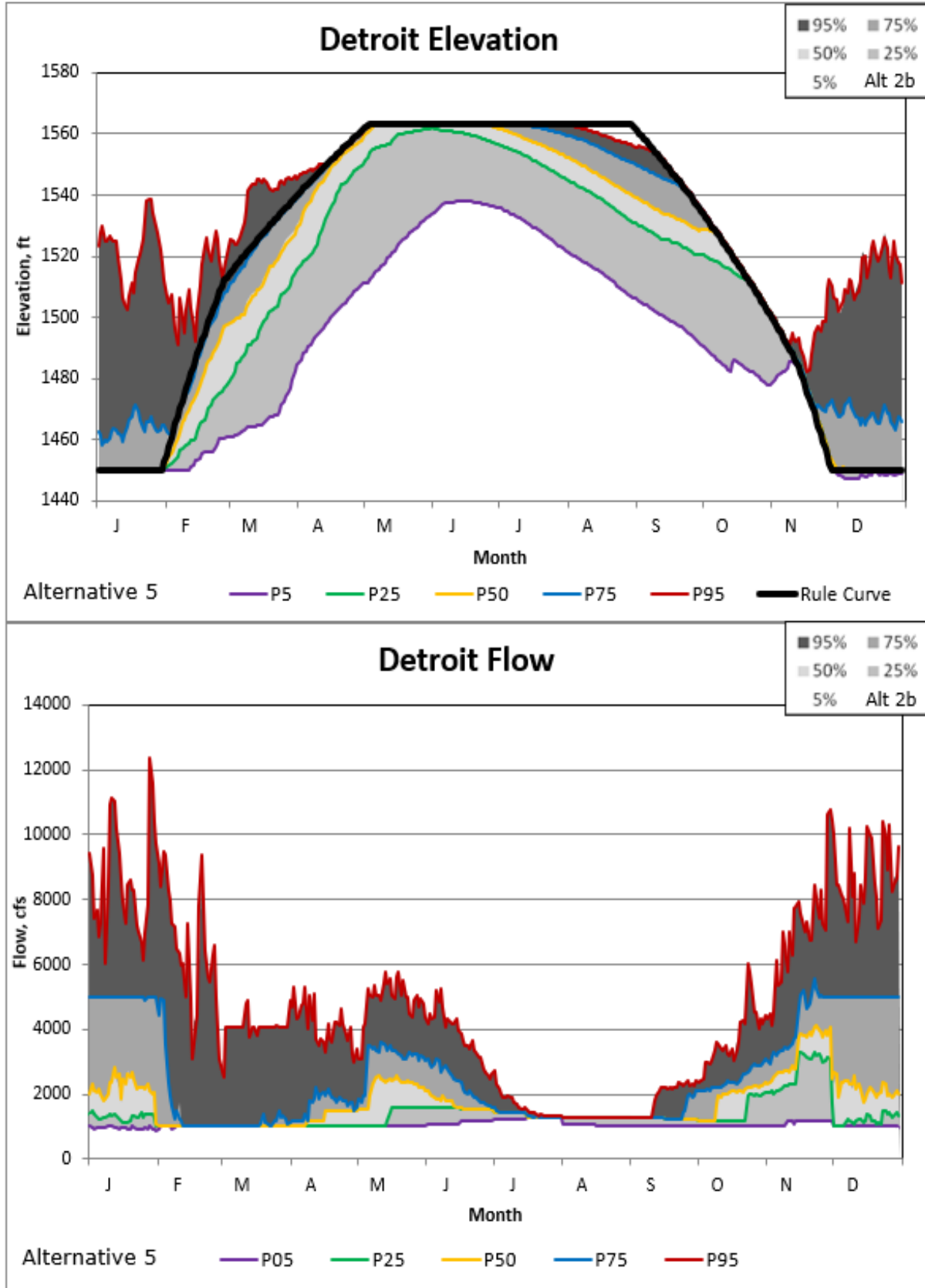

Figure 5-236. Detroit Alternatives 5/2B Non-exceedance Plot.

Willamette Valley System Operations and Maintenance
Environmental Impact Statement

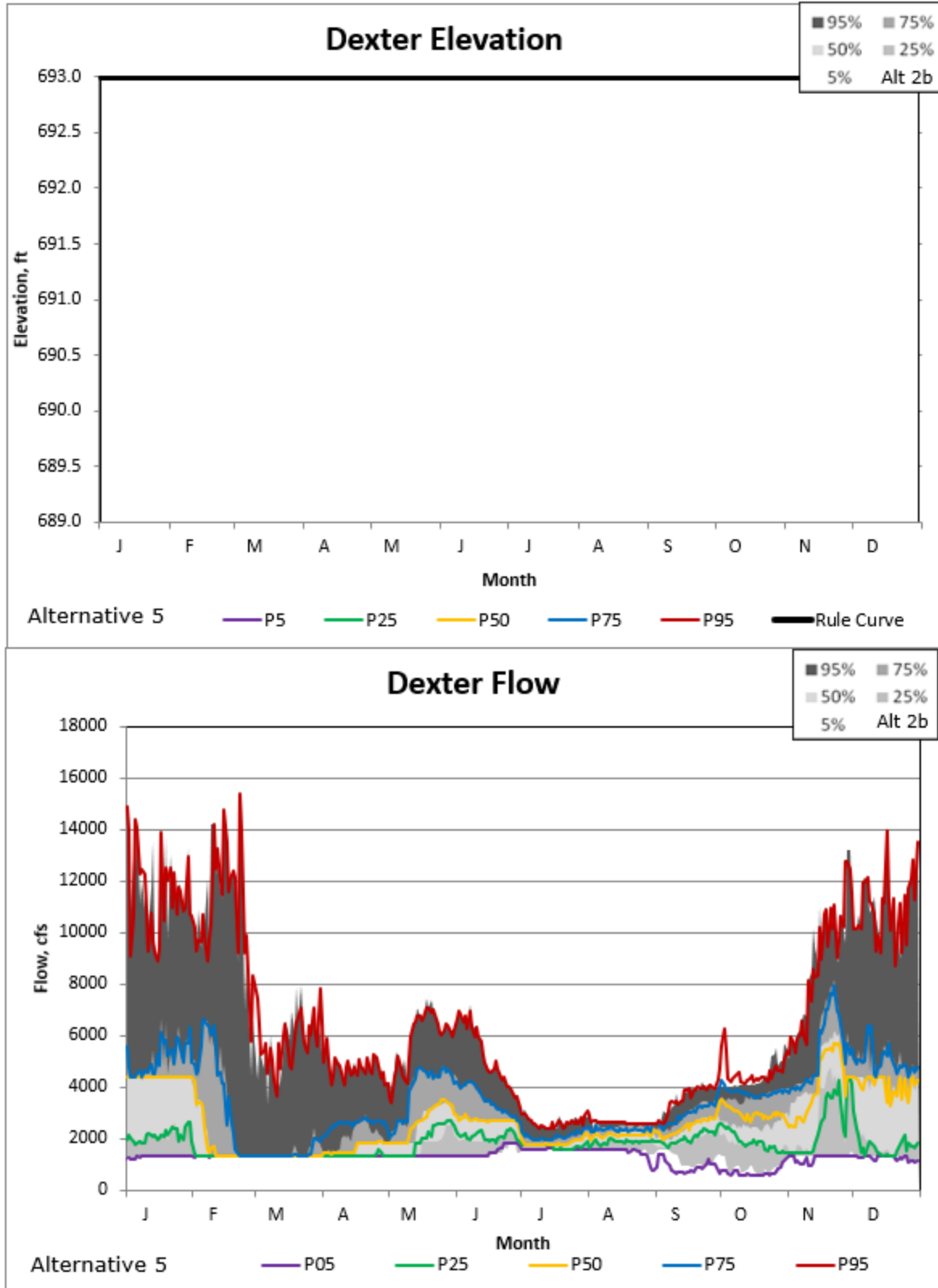

Figure 5-237. Dexter Alternatives 5/2B Non-exceedance Plot.

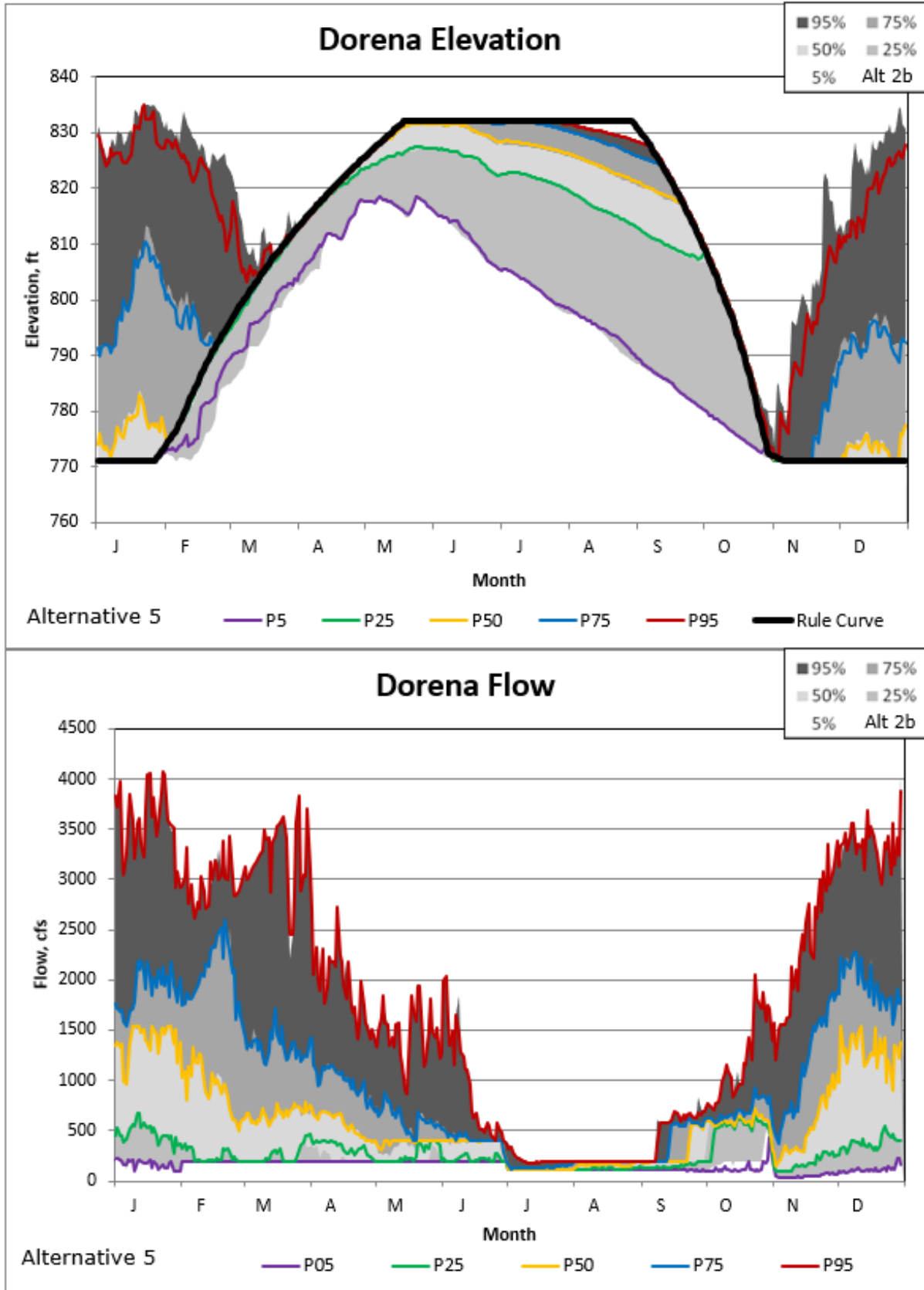

Figure 5-238. Dorena Alternatives 5/2B Non-exceedance Plot.

Willamette Valley System Operations and Maintenance
Environmental Impact Statement

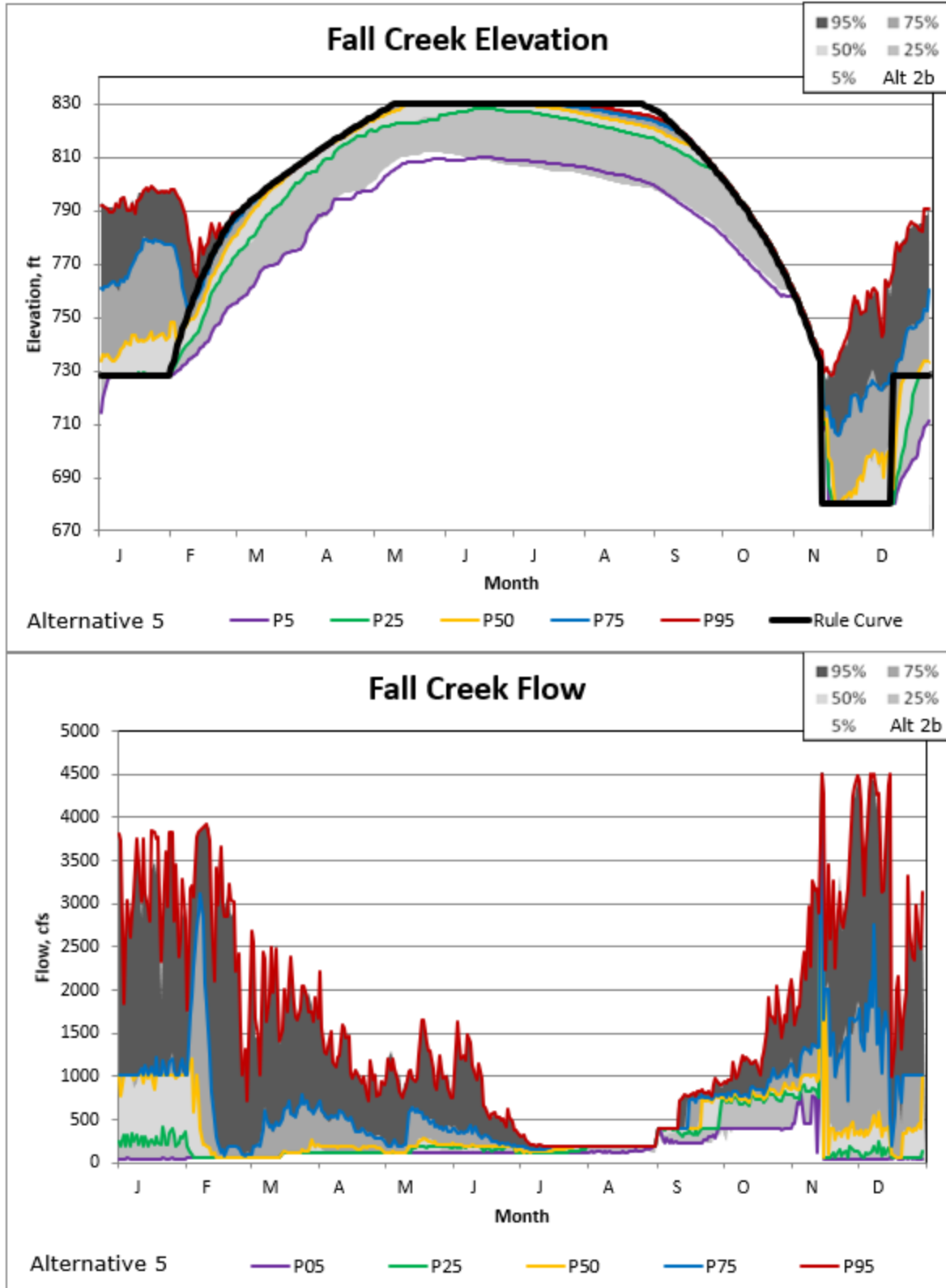

Figure 5-239. Fall Creek Alternatives 5/2B Non-exceedance Plot.

Willamette Valley System Operations and Maintenance
Environmental Impact Statement

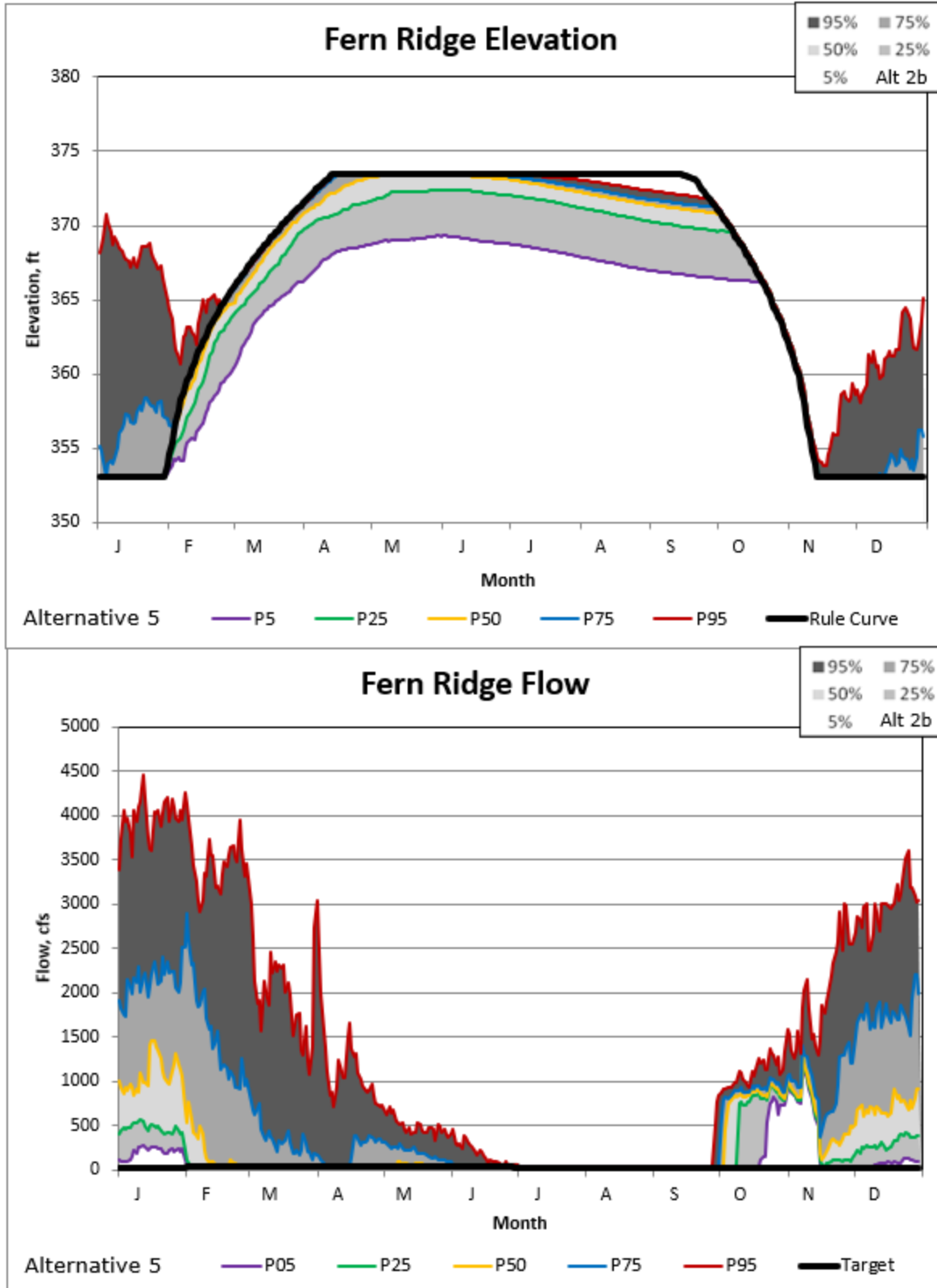

Figure 5-240. Fern Ridge Alternatives 5/2B Non-exceedance Plot.

Willamette Valley System Operations and Maintenance
 Environmental Impact Statement

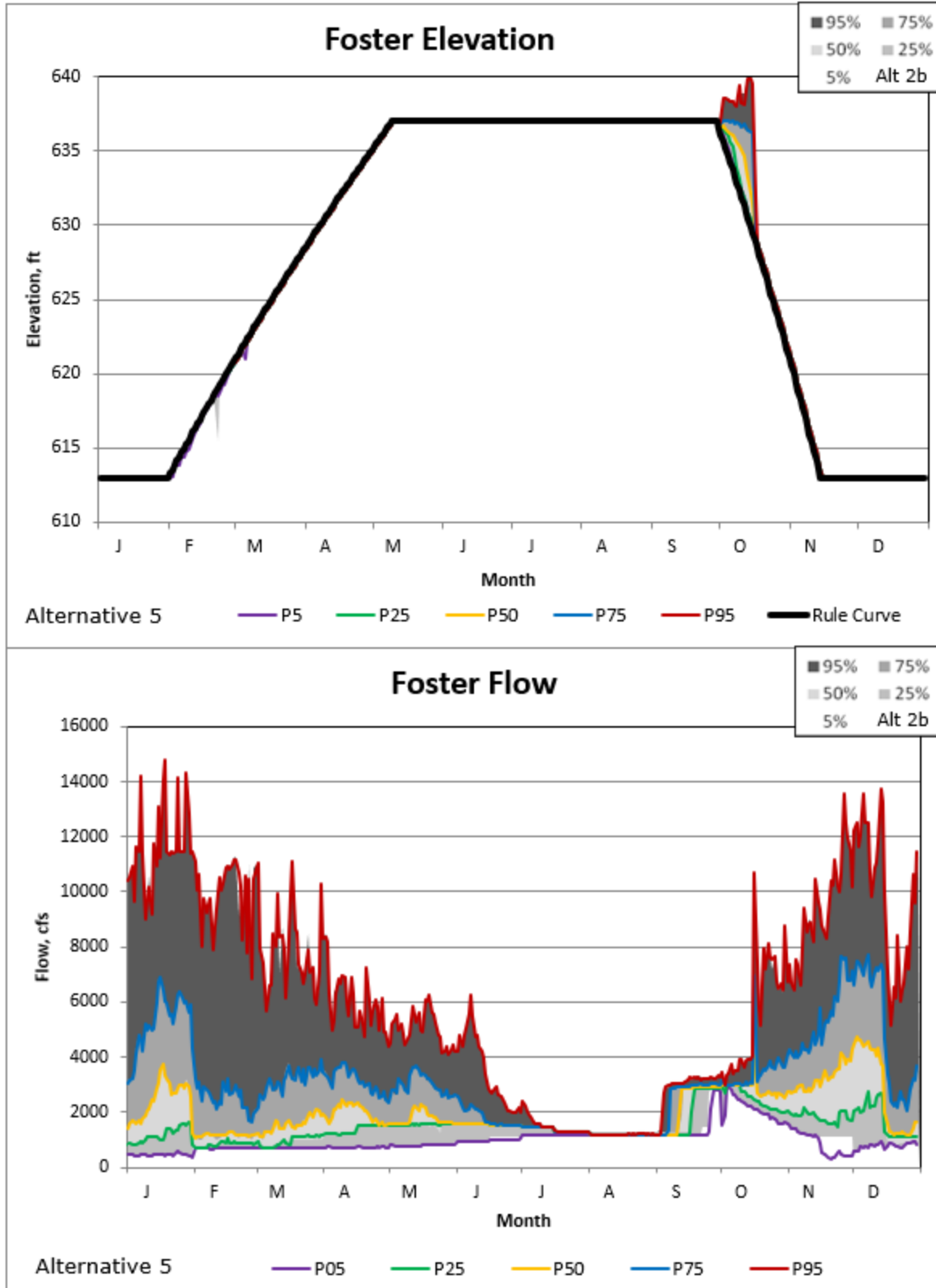

Figure 5-241. Foster Alternatives 5/2B Non-exceedance Plot.

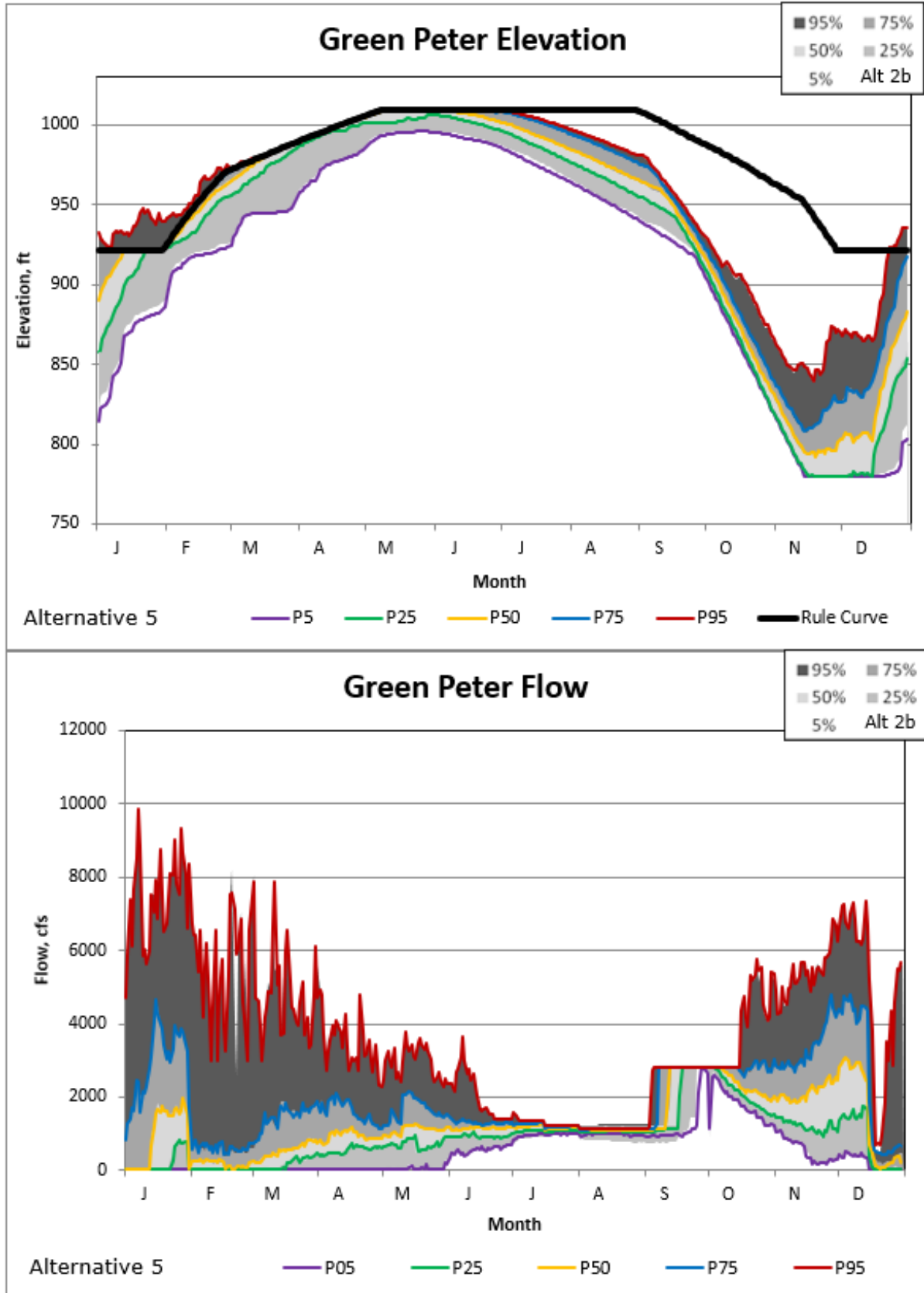

Figure 5-242. Green Peter Alternatives 5/2B Non-exceedance Plot.

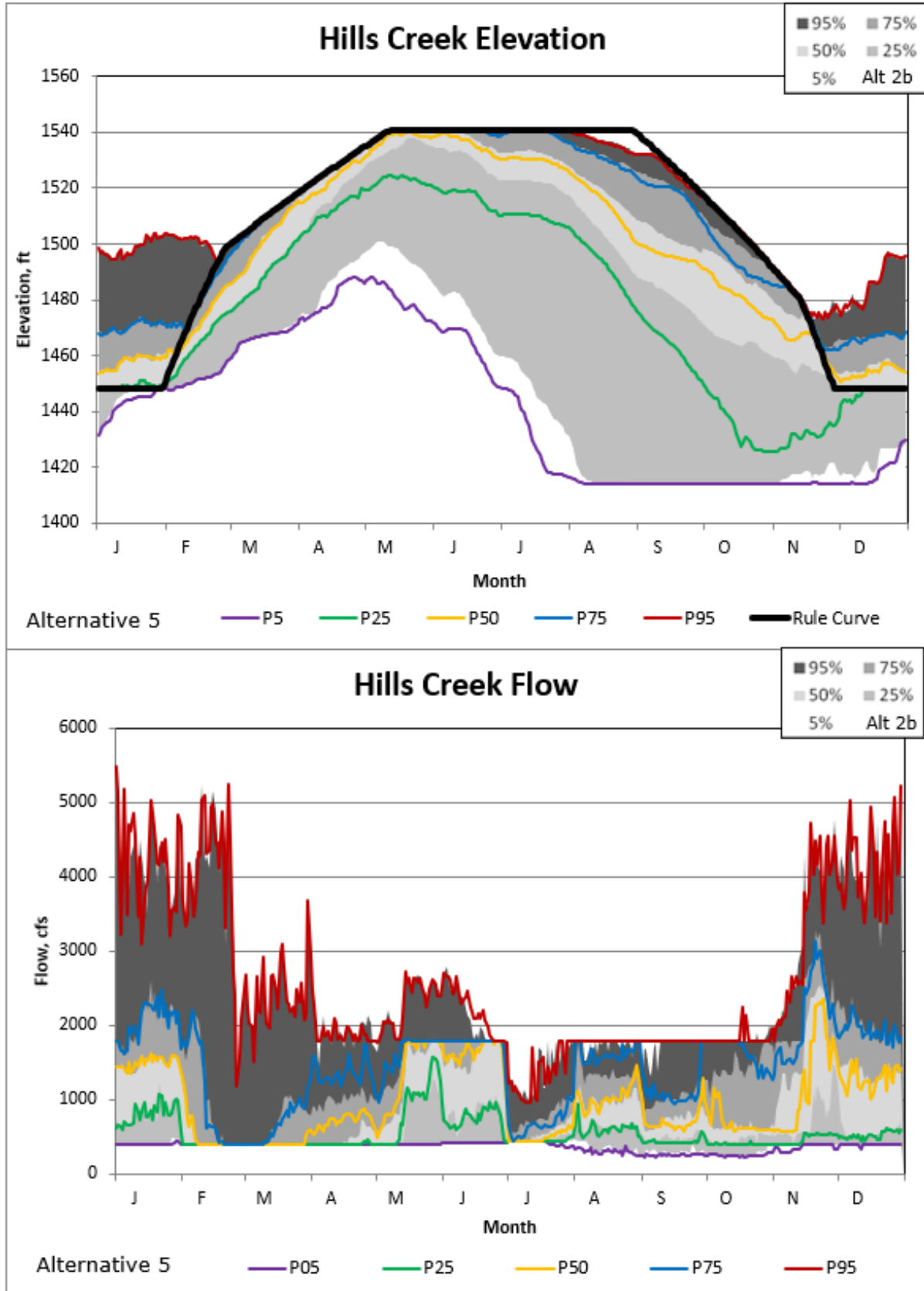

Figure 5-243. Hills Creek Alternatives 5/2B Non-exceedance Plot.

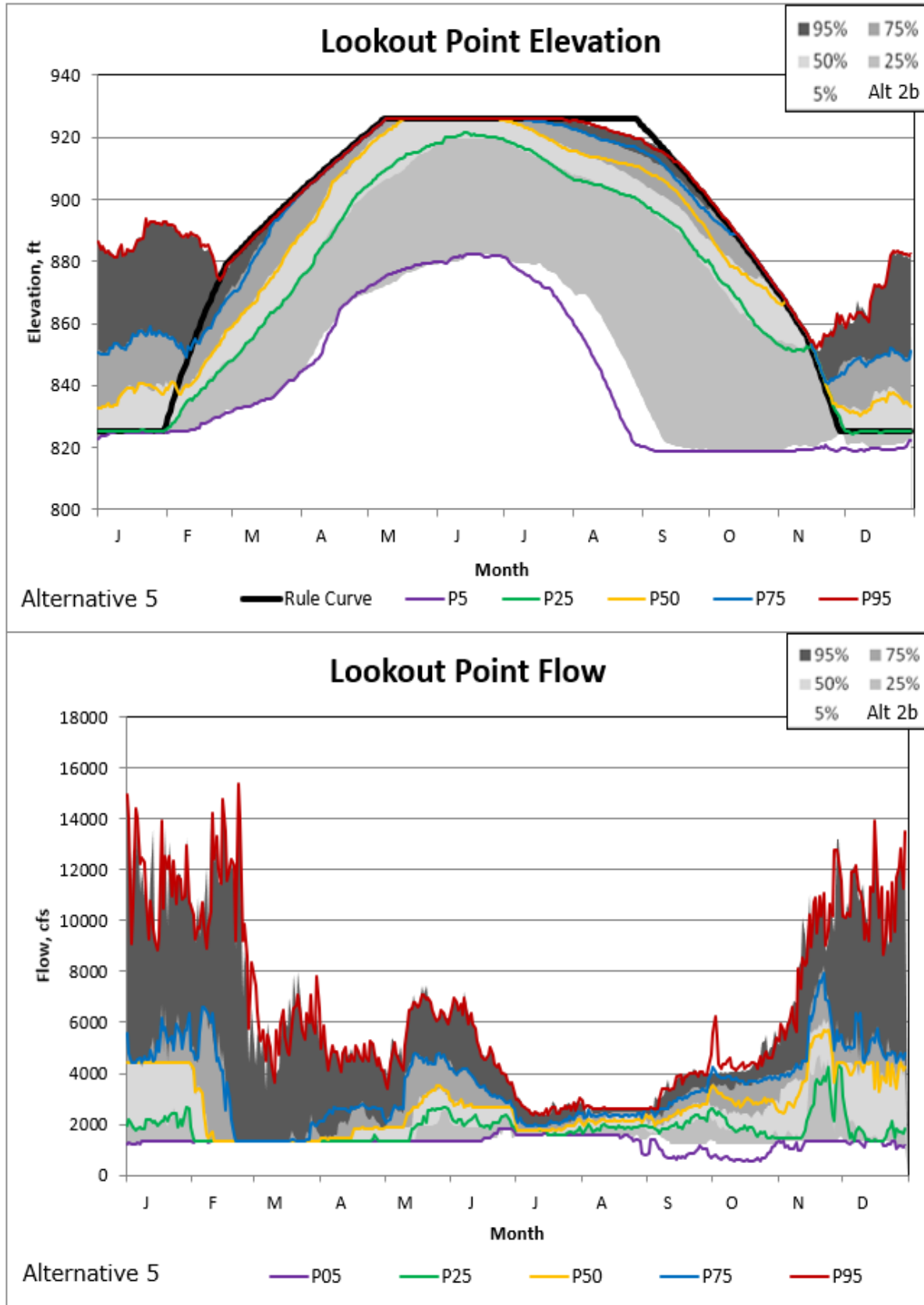

Figure 5-244. Lookout Point Alternatives 5/2B Non-exceedance Plot.

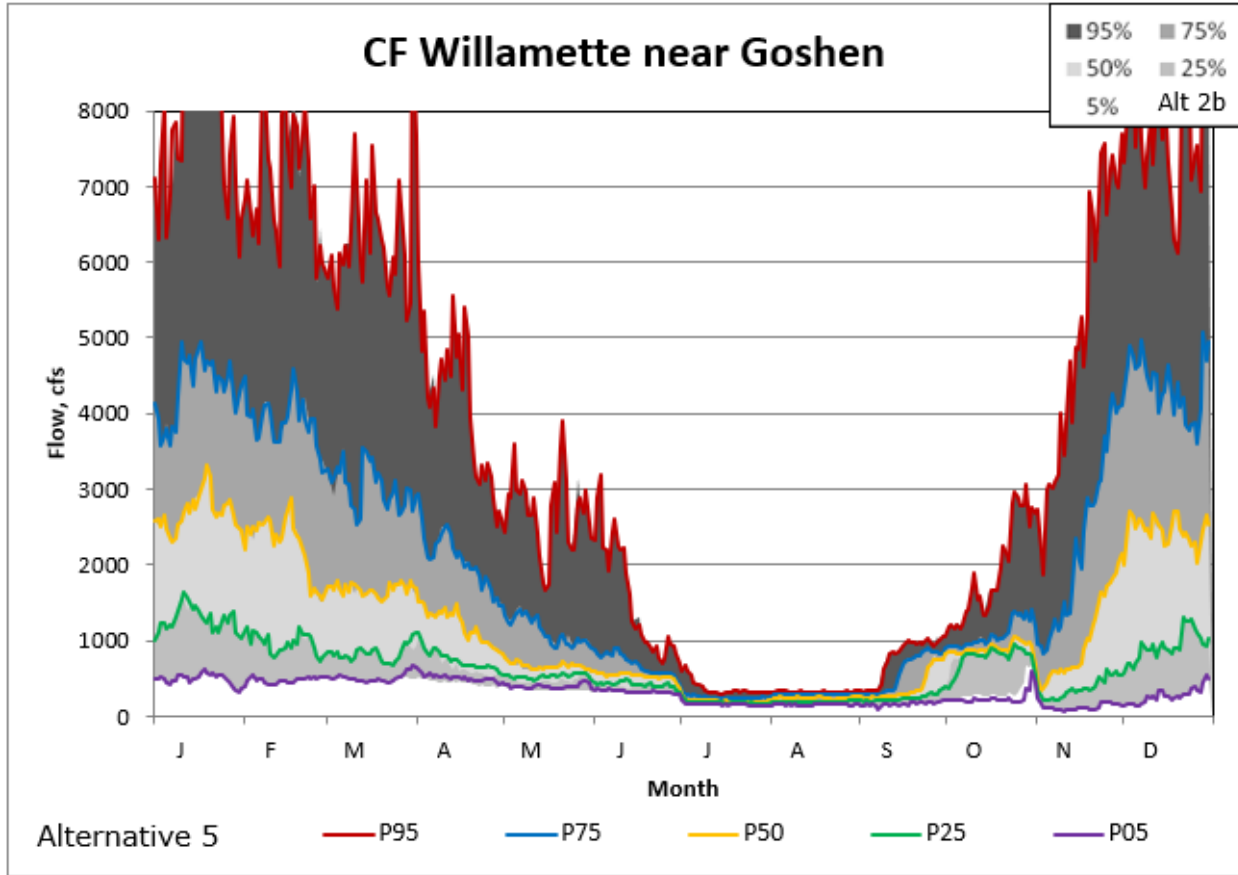

Figure 5-245. Goshen Alternatives 5/2B Non-exceedance Plot.

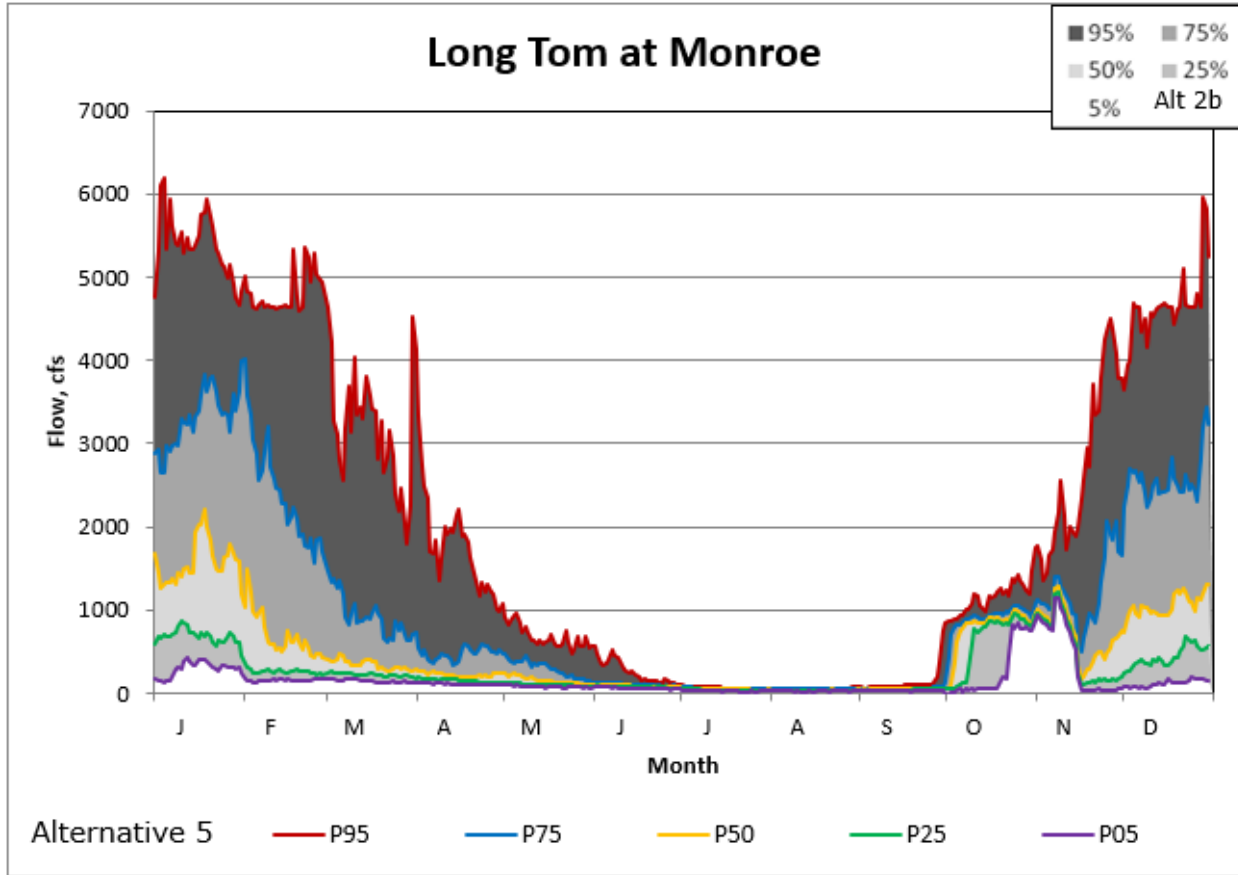

Figure 5-246. Monroe Alternatives 5/2B Non-exceedance Plot.

Willamette Valley System Operations and Maintenance
Environmental Impact Statement

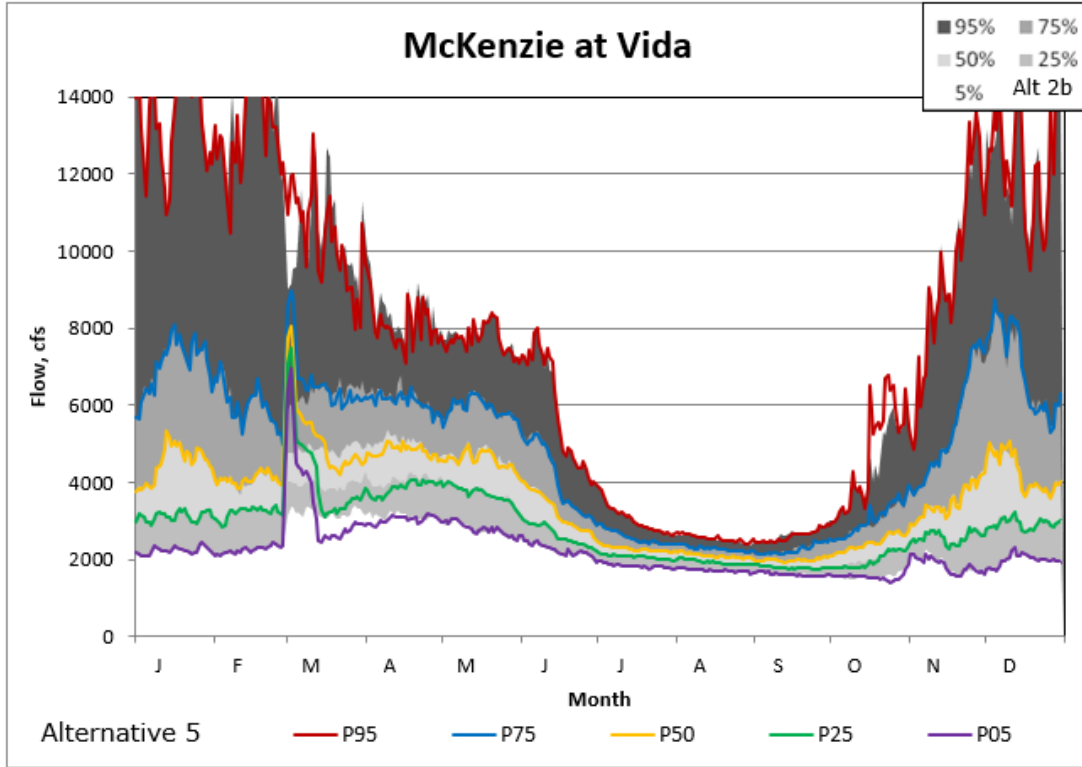

Figure 5-247. Vida Alternatives 5/2B Non-exceedance Plot.

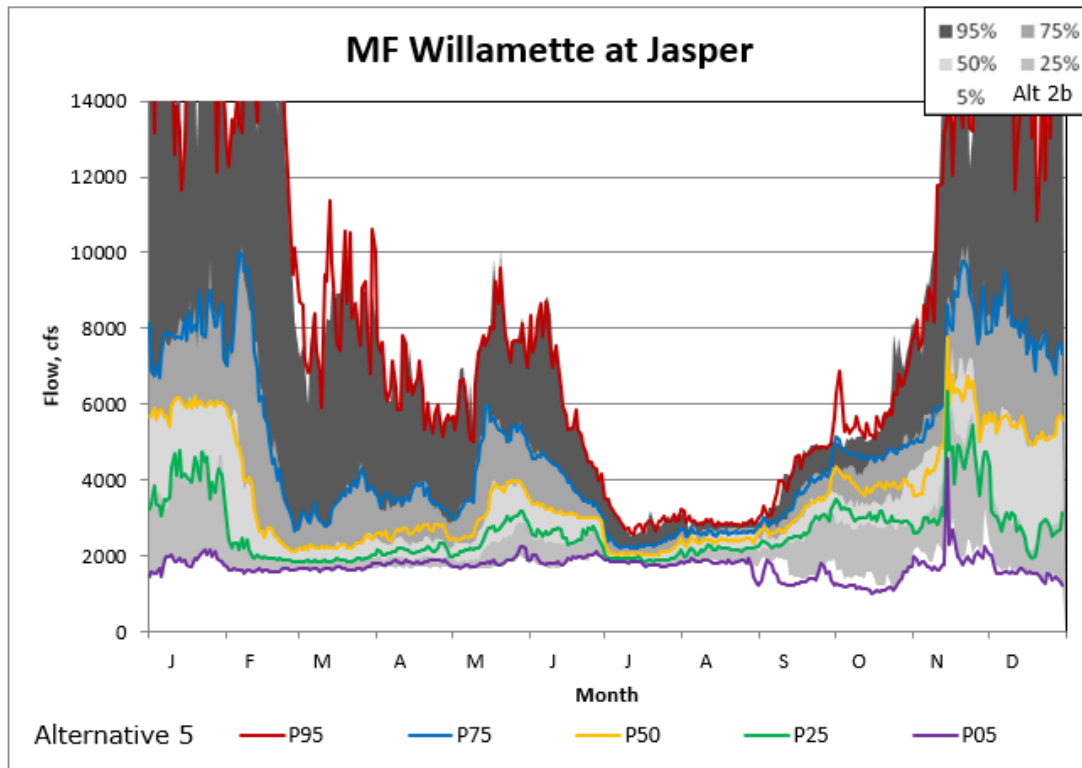

Figure 5-248. Jasper Alternatives 5/2B Non-exceedance Plot.

*Willamette Valley System Operations and Maintenance
Environmental Impact Statement*

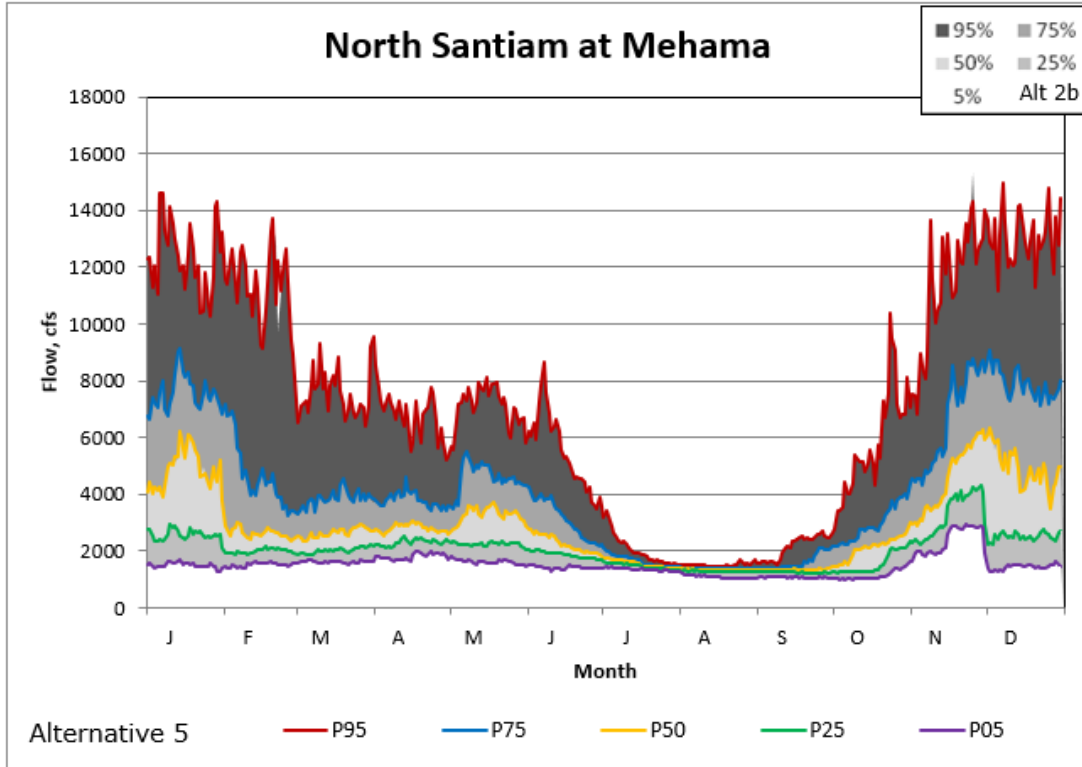

Figure 5-249. Mehama Alternatives 5/2B Non-exceedance Plot.

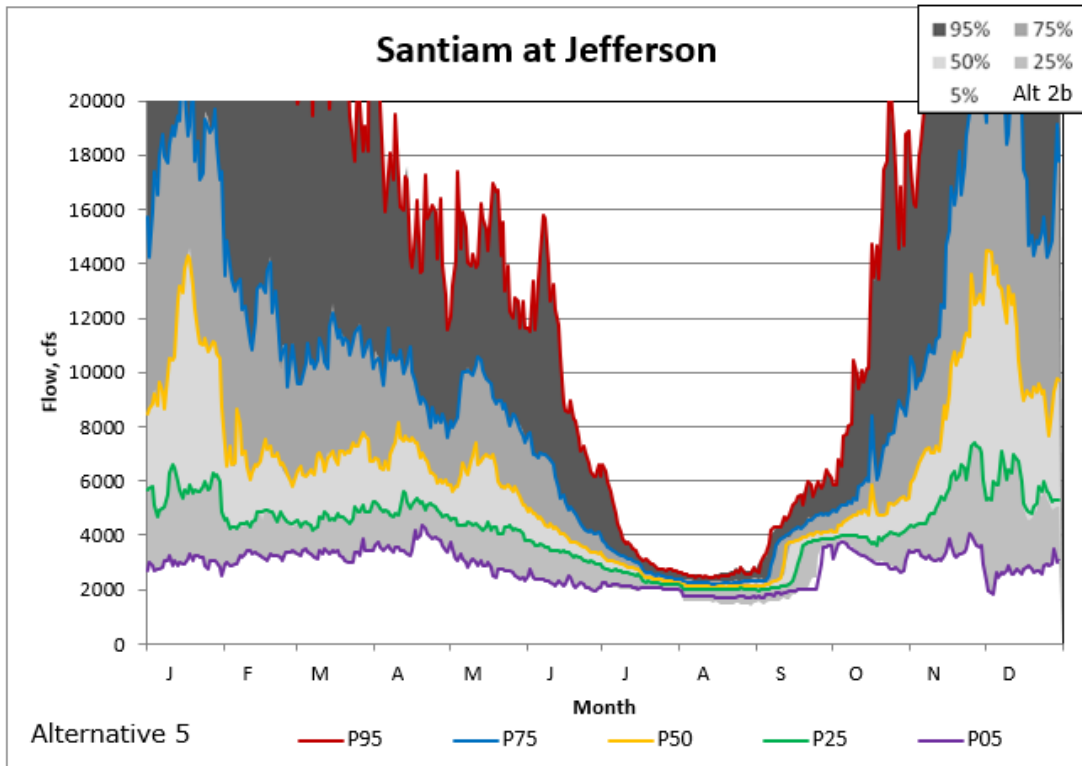

Figure 5-250. Jefferson Alternatives 5/2B Non-exceedance Plot.

Willamette Valley System Operations and Maintenance
Environmental Impact Statement

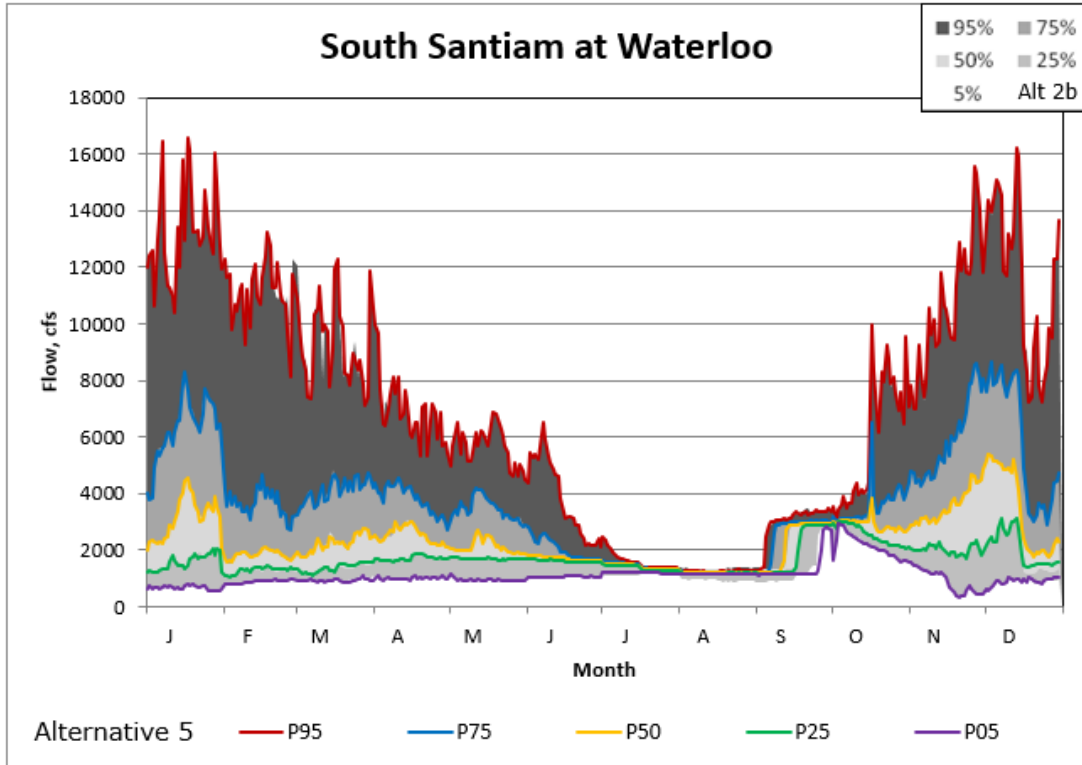

Figure 5-251. Waterloo Alternatives 5/2B Non-exceedance Plot.

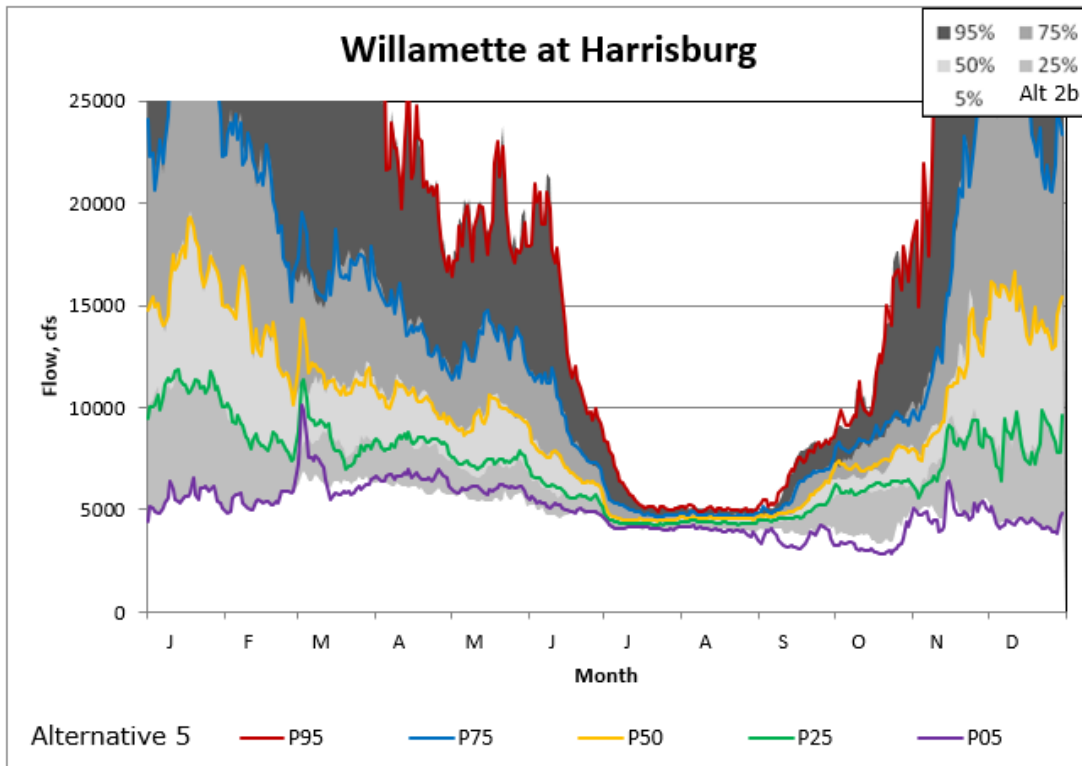

Figure 5-252. Harrisburg Alternatives 5/2B Non-exceedance Plot.

Willamette Valley System Operations and Maintenance
Environmental Impact Statement

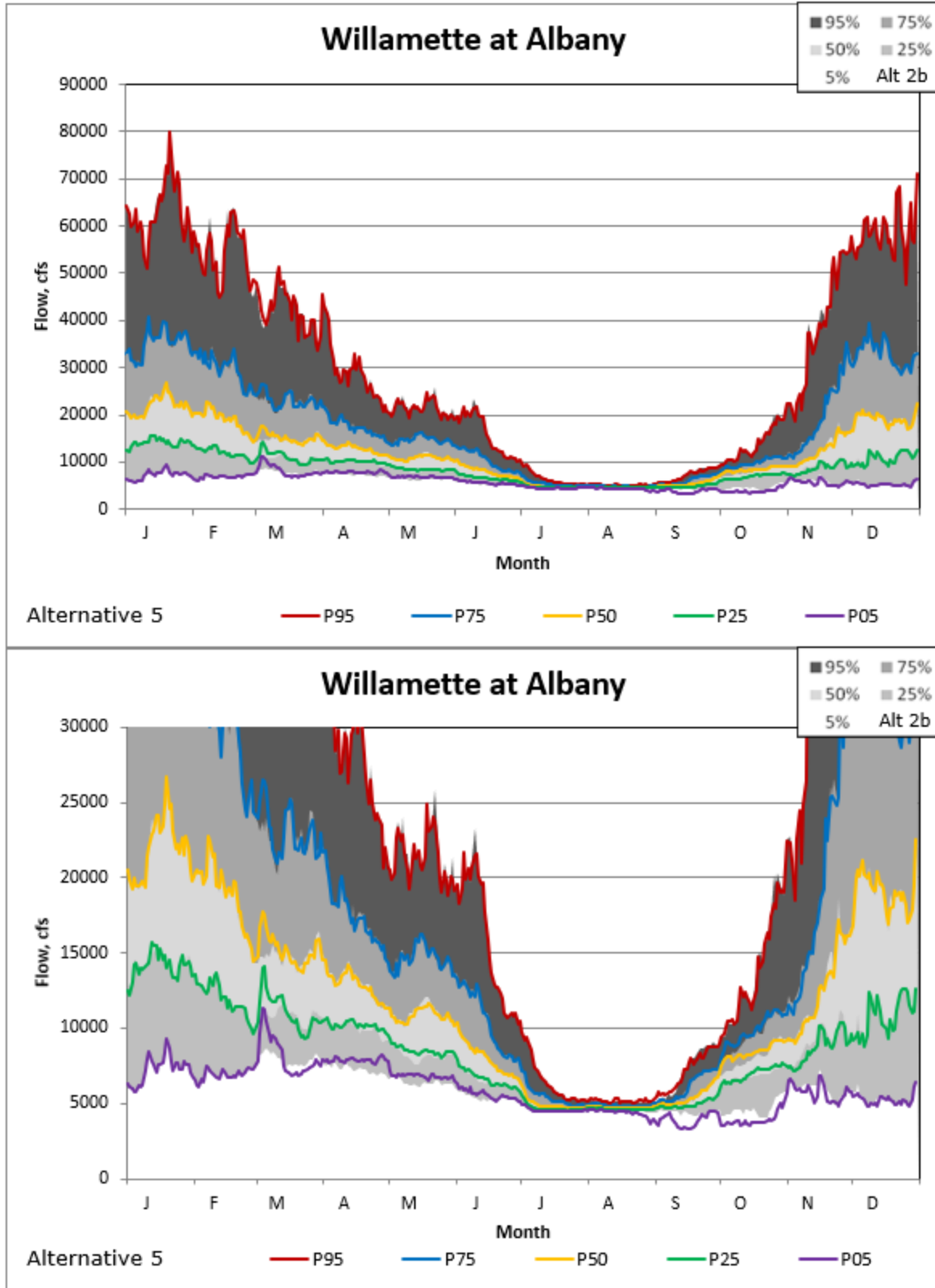

Figure 5-253. Albany Alternatives 5/2B Non-exceedance Plot.

Willamette Valley System Operations and Maintenance
Environmental Impact Statement

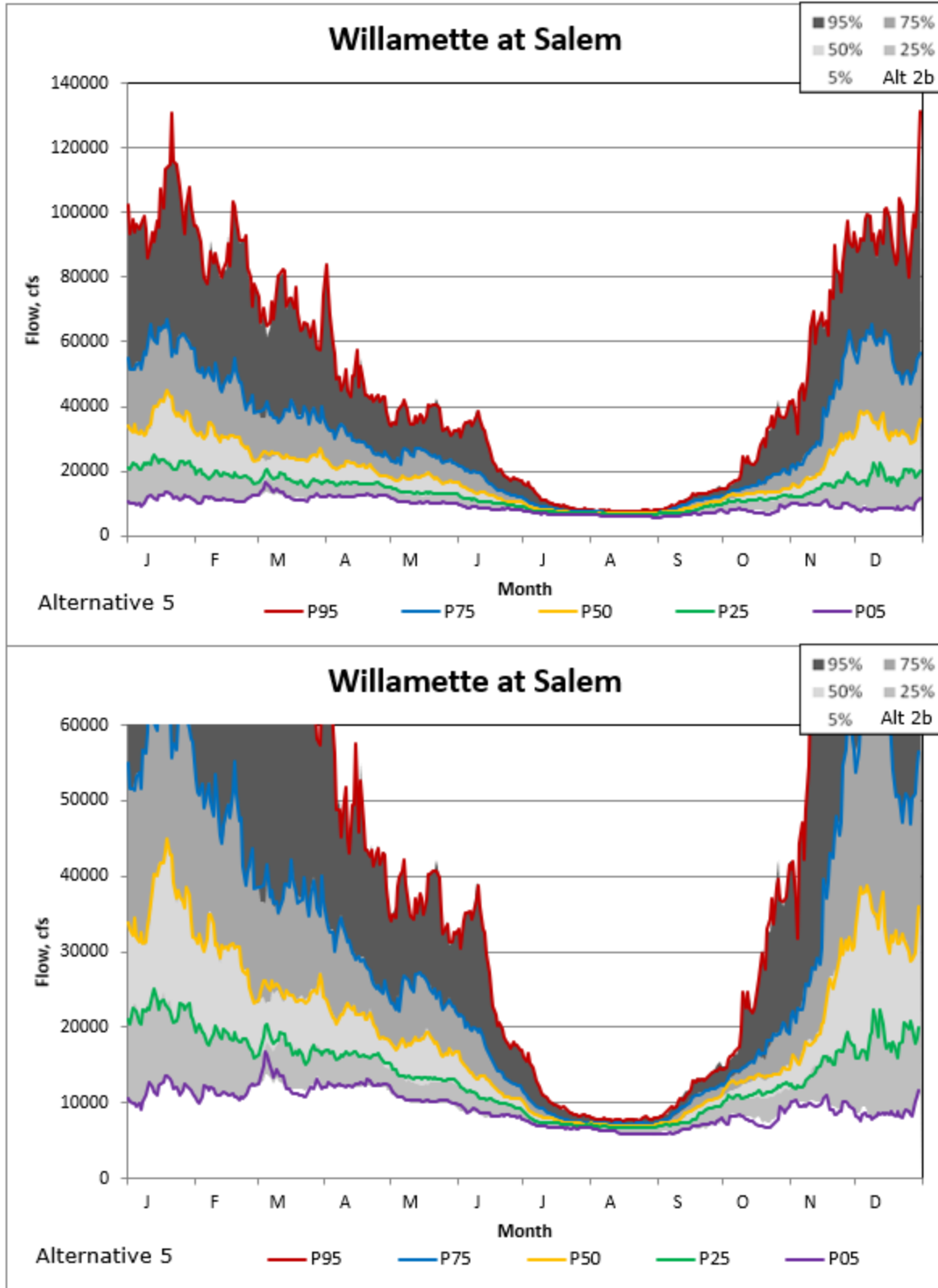

Figure 5-254. Salem Alternatives 5/2B Non-exceedance Plot.

5.13 Alternative 5/Alternative 2B WY 2009–2019 Plots

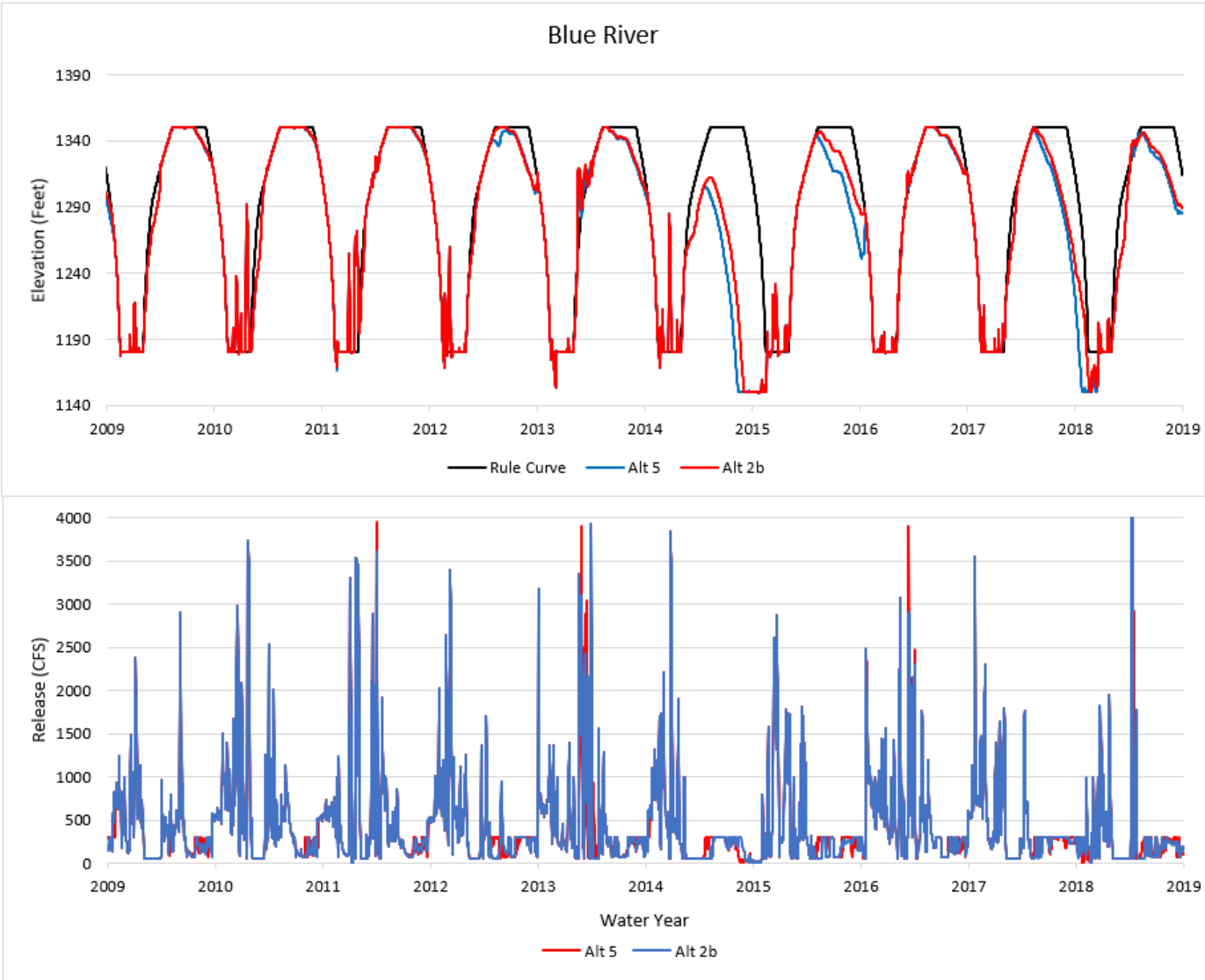

Figure 5-255. Blue River Alternatives 5/2B WY 2009–2019 Plot.

Willamette Valley System Operations and Maintenance
Environmental Impact Statement

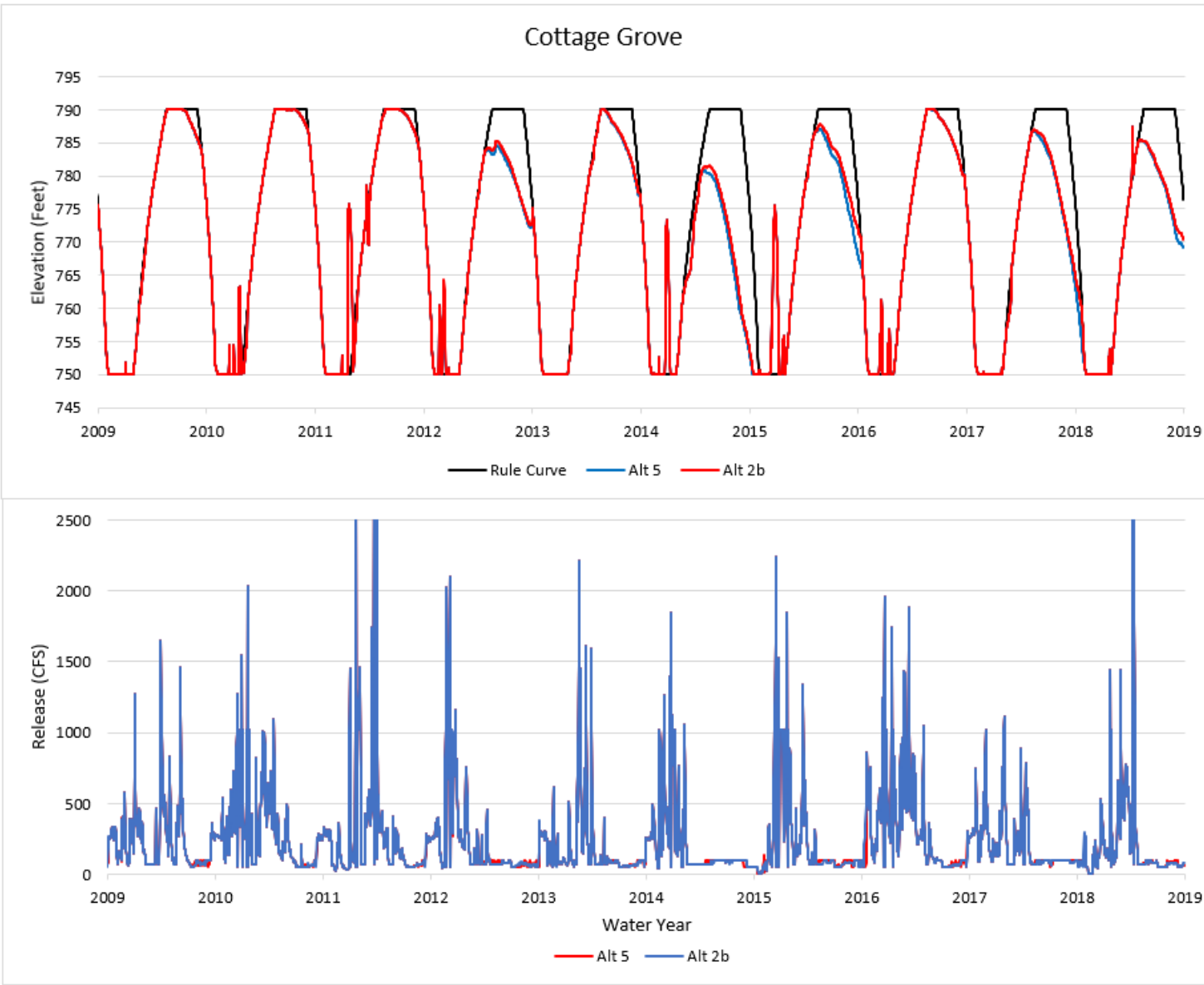

Figure 5-256. Cottage Grove Alternatives 5/2B WY 2009–2019 Plot.

Willamette Valley System Operations and Maintenance
Environmental Impact Statement

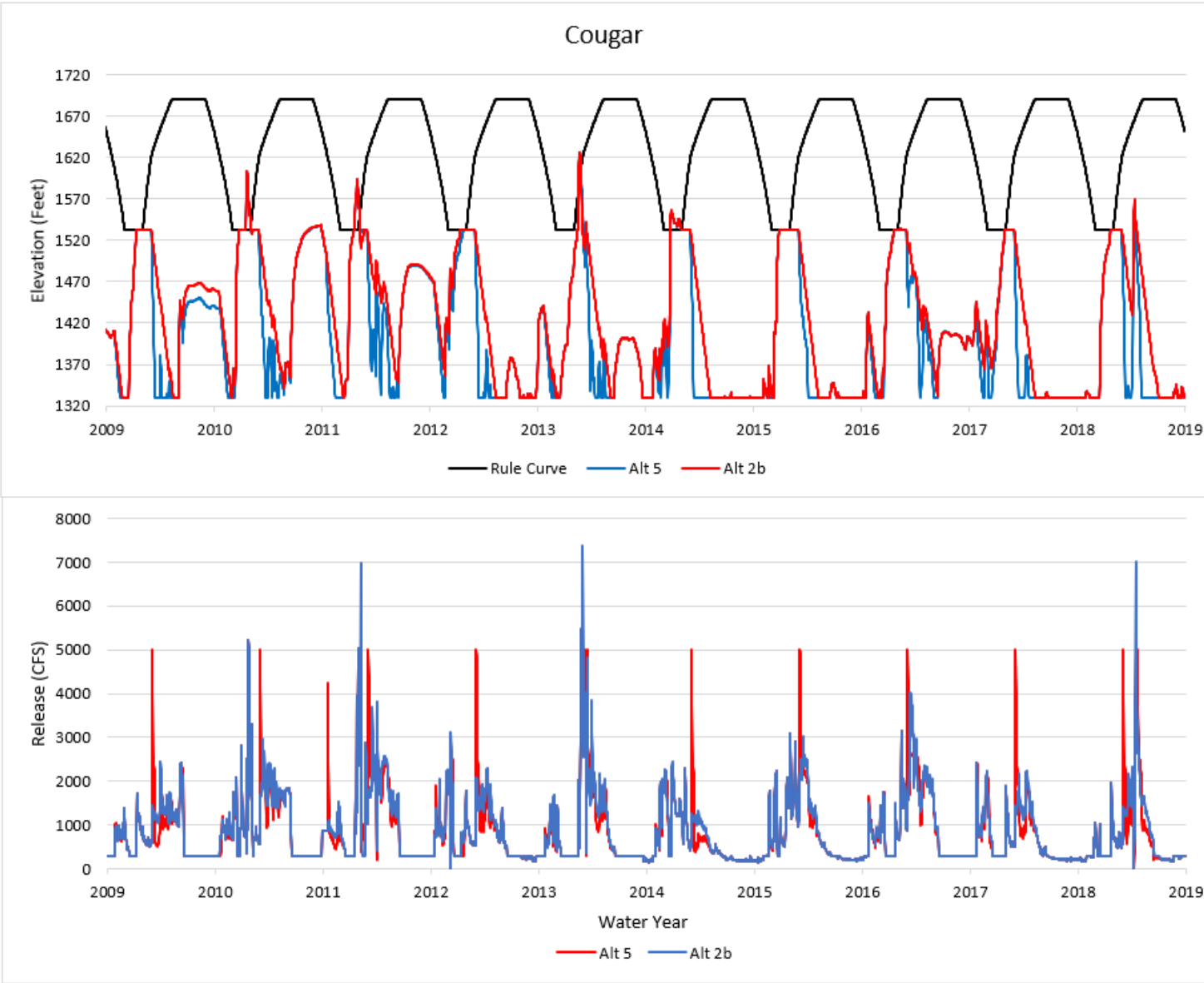

Figure 5-257. Cougar Alternatives 5/2B WY 2009–2019 Plot.

Willamette Valley System Operations and Maintenance
Environmental Impact Statement

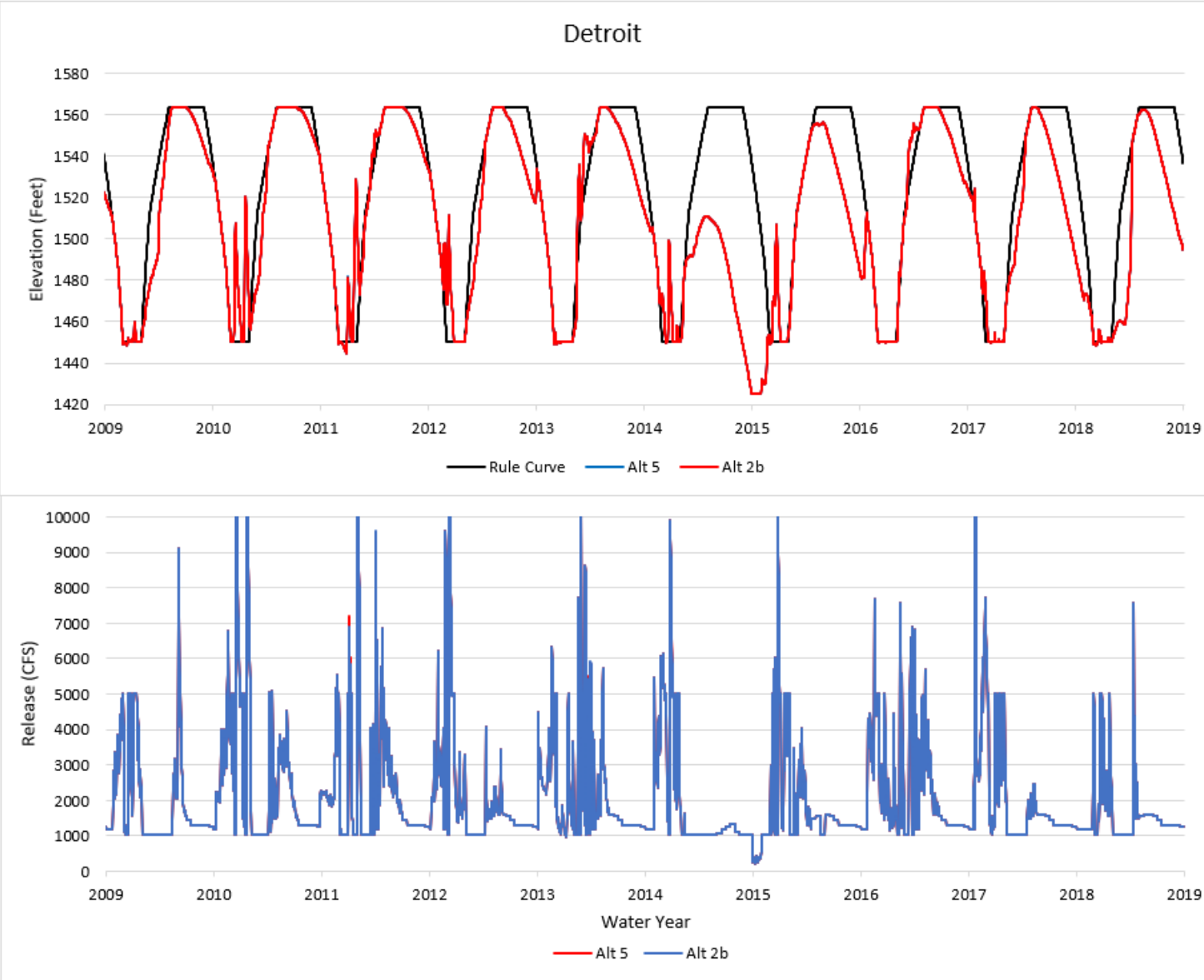

Figure 5-258. Detroit Alternatives 5/2B WY 2009–2019 Plot.

Willamette Valley System Operations and Maintenance
Environmental Impact Statement

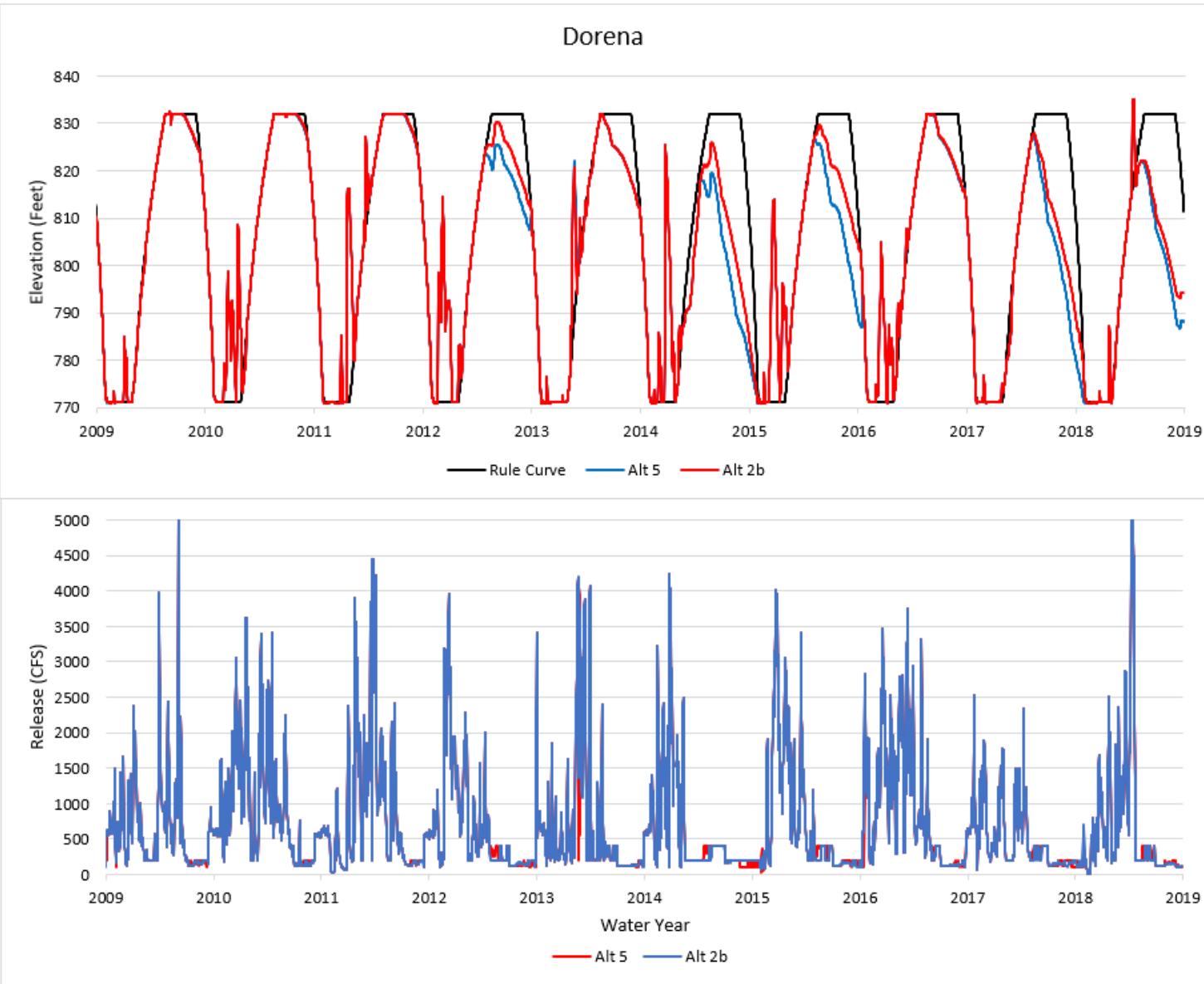

Figure 5-259. Dorena Alternatives 5/2B WY 2009–2019 Plot.

Willamette Valley System Operations and Maintenance
Environmental Impact Statement

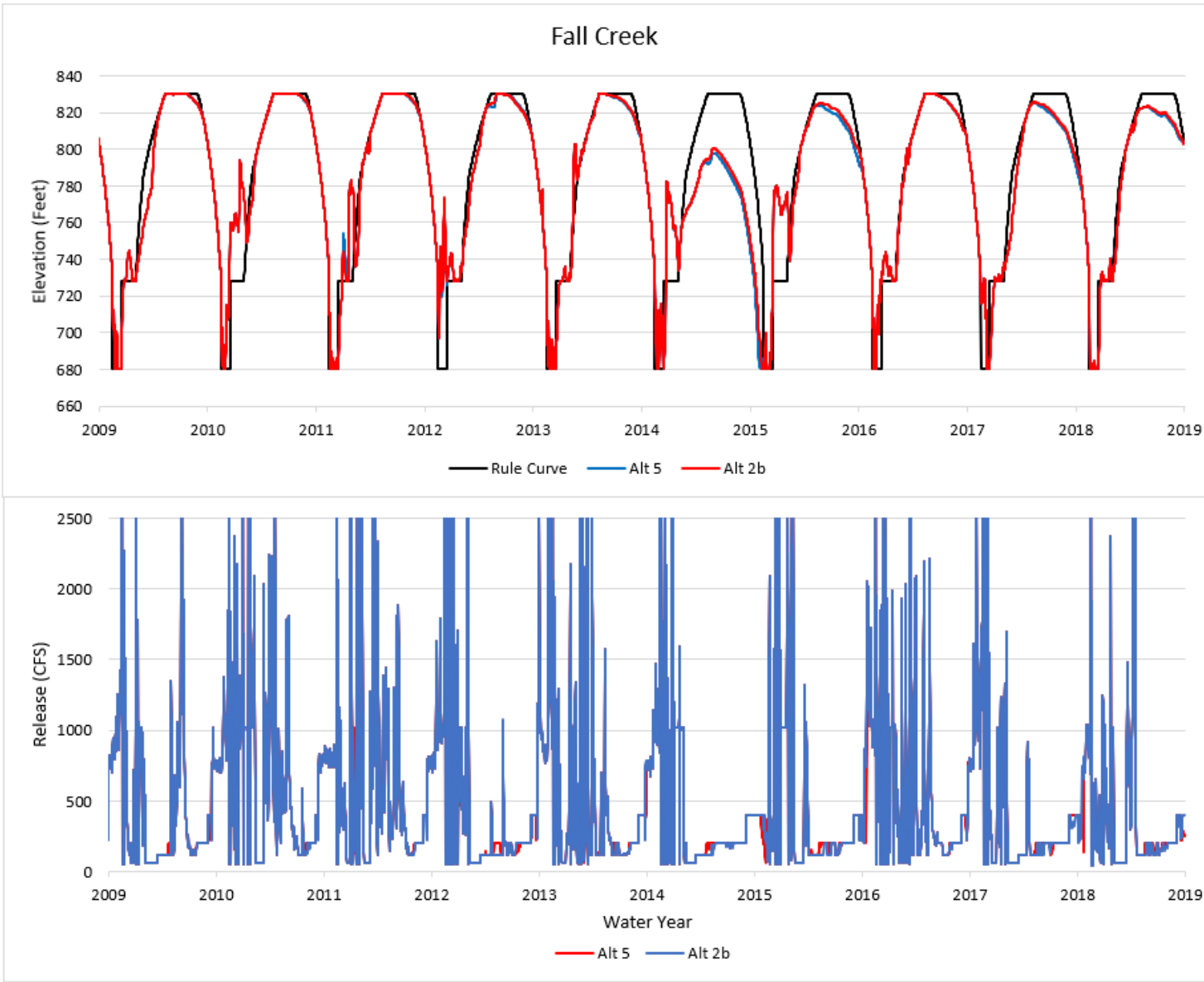

Figure 5-260. Fall Creek Alternatives 5/2B WY 2009–2019 Plot.

Willamette Valley System Operations and Maintenance
Environmental Impact Statement

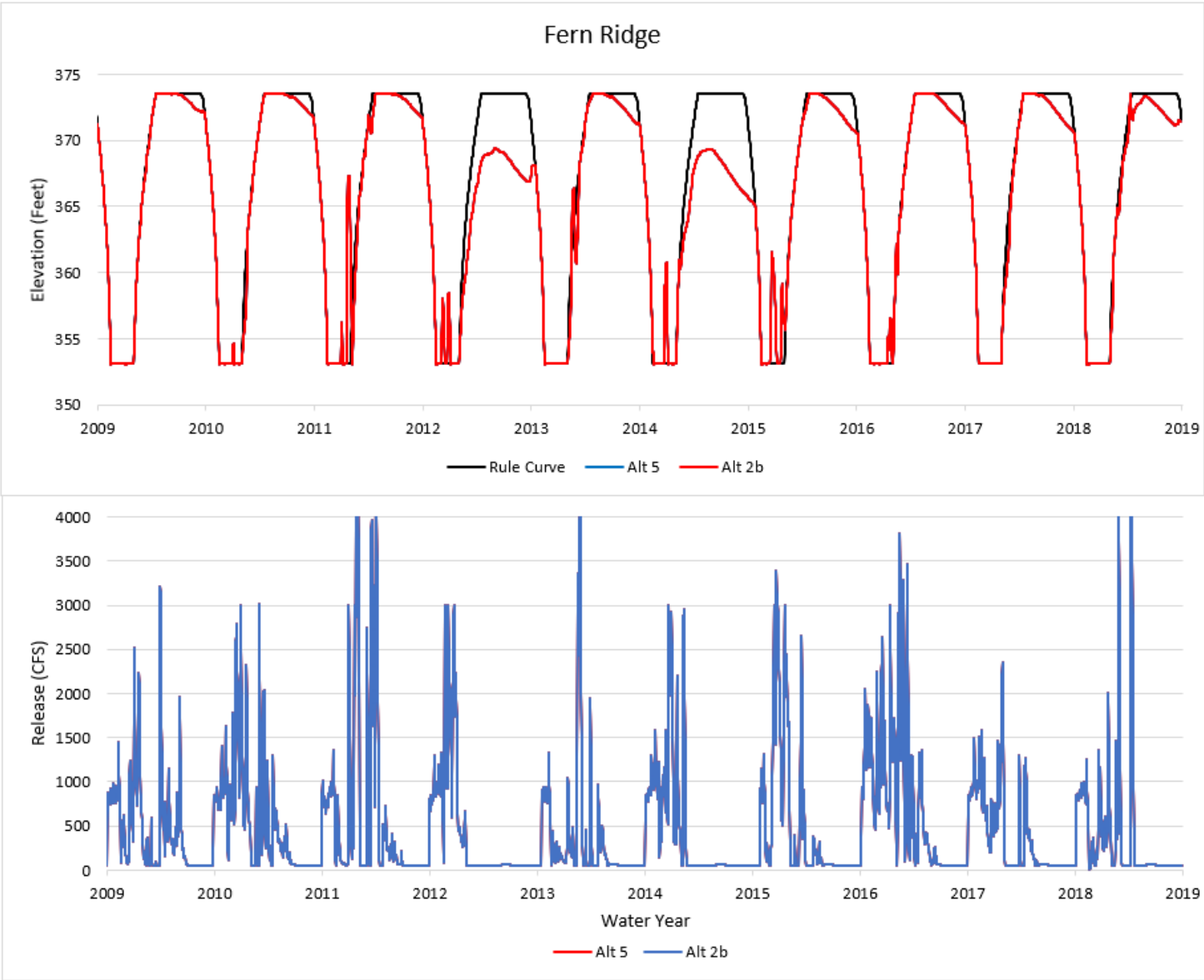

Figure 5-261. Fern Ridge Alternatives 5/2B WY 2009–2019 Plot.

Willamette Valley System Operations and Maintenance
Environmental Impact Statement

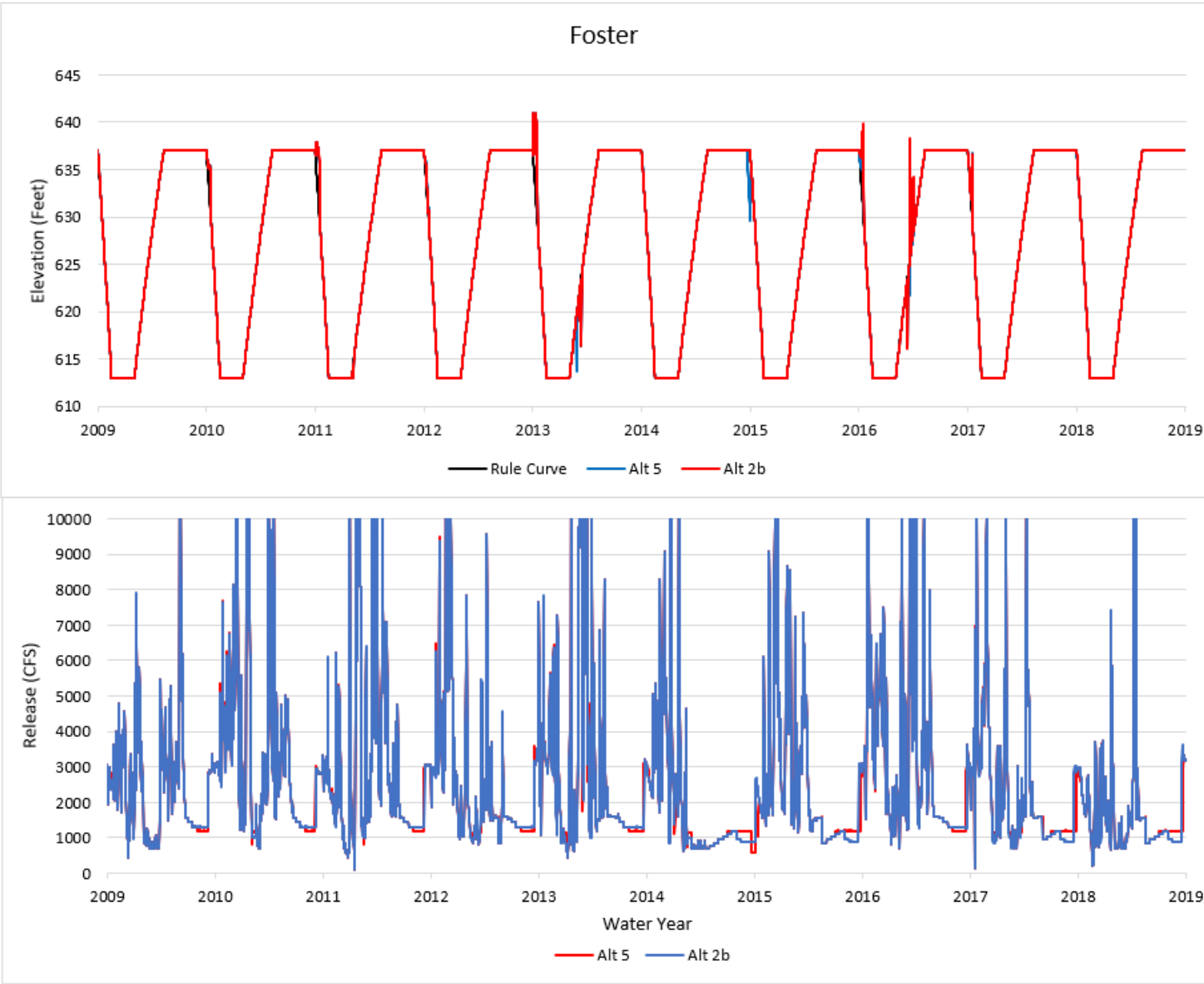

Figure 5-262. Foster Alternatives 5/2B WY 2009–2019 Plot.

Willamette Valley System Operations and Maintenance
Environmental Impact Statement

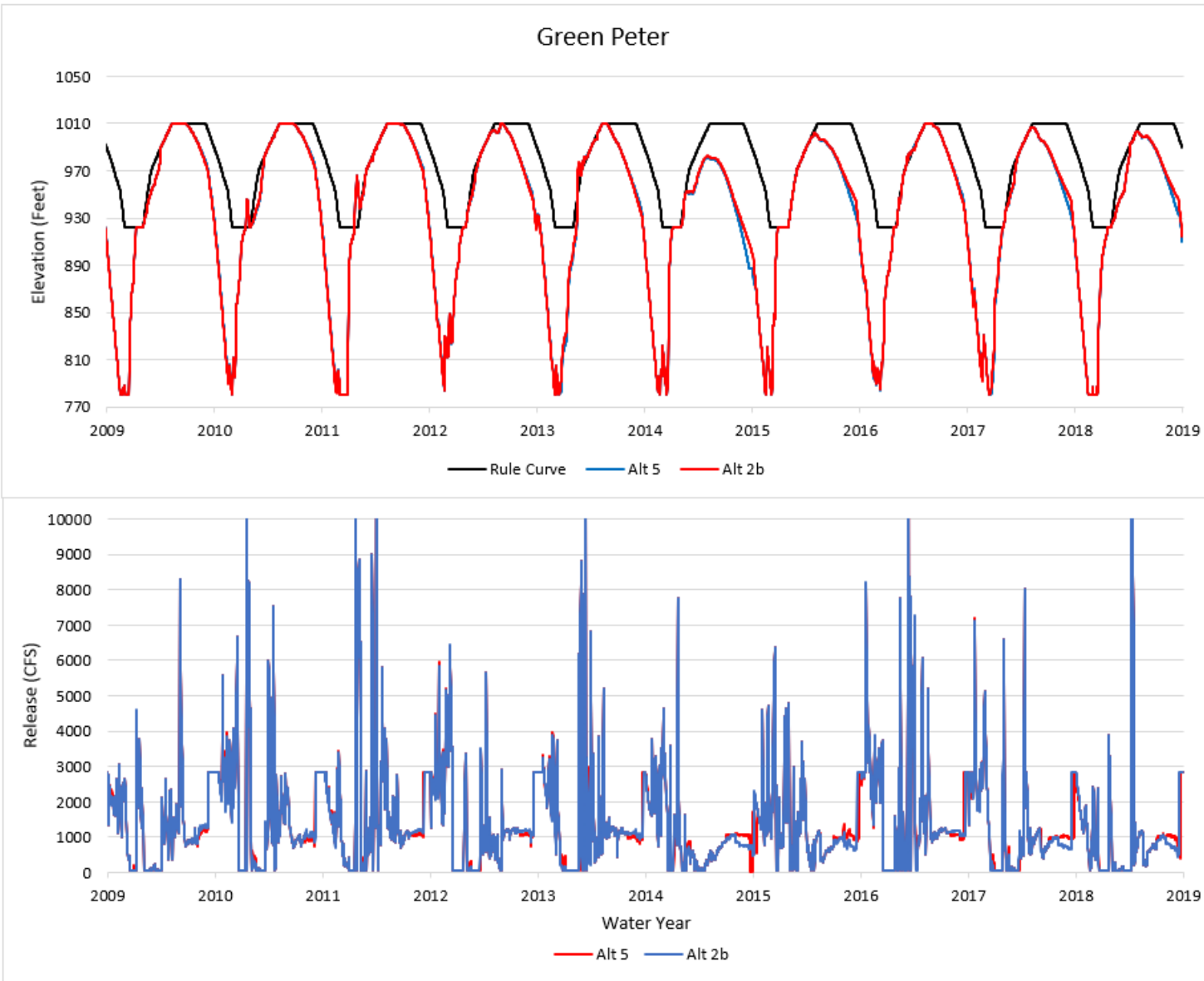

Figure 5-263. Green Peter Alternatives 5/2B WY 2009–2019 Plot.

Willamette Valley System Operations and Maintenance
Environmental Impact Statement

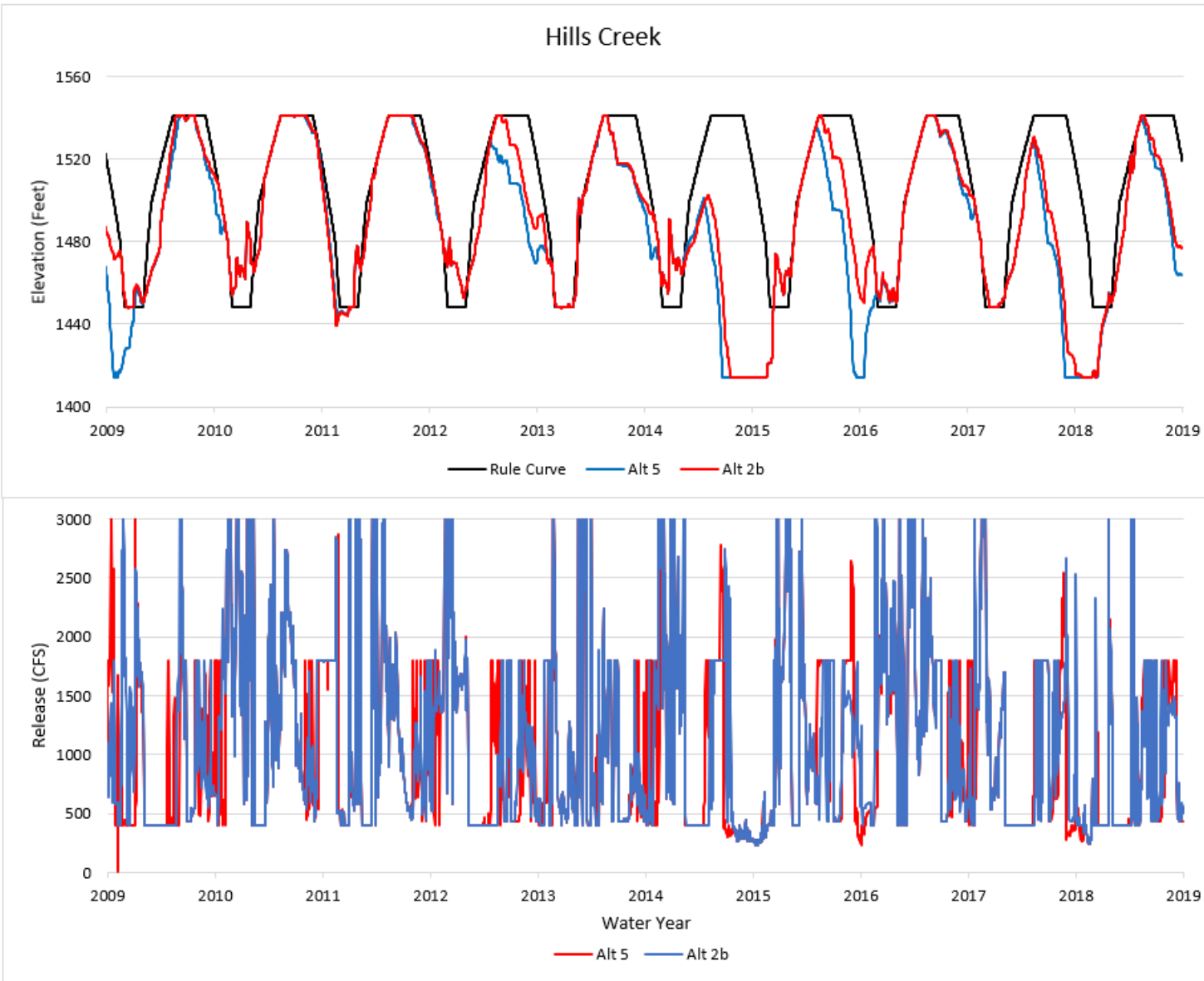

Figure 5-264. Hills Creek Alternatives 5/2B WY 2009–2019 Plot.

Willamette Valley System Operations and Maintenance
Environmental Impact Statement

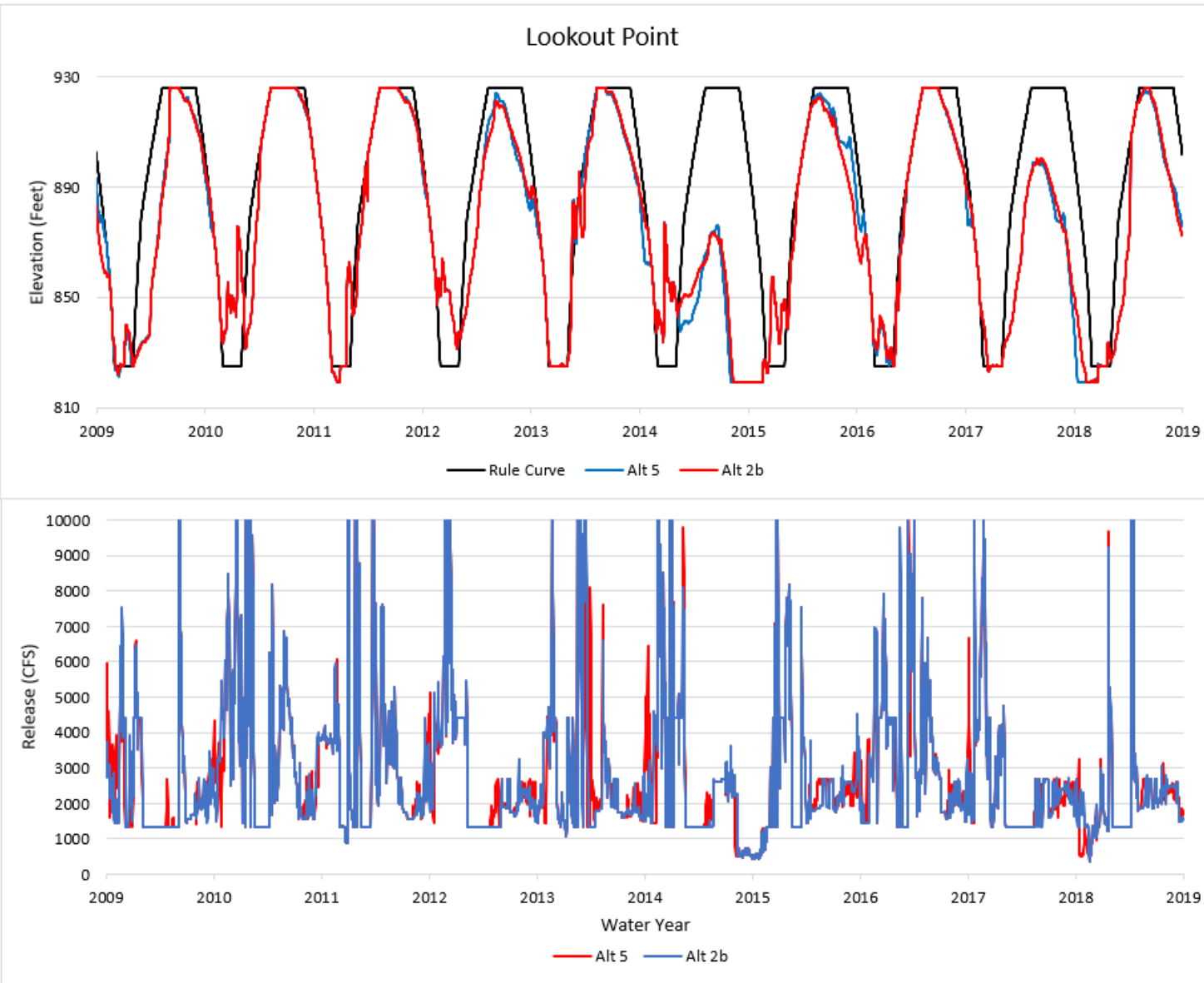

Figure 5-265. Lookout Point Alternatives 5/2B WY 2009–2019 Plot.

Willamette Valley System Operations and Maintenance
Environmental Impact Statement

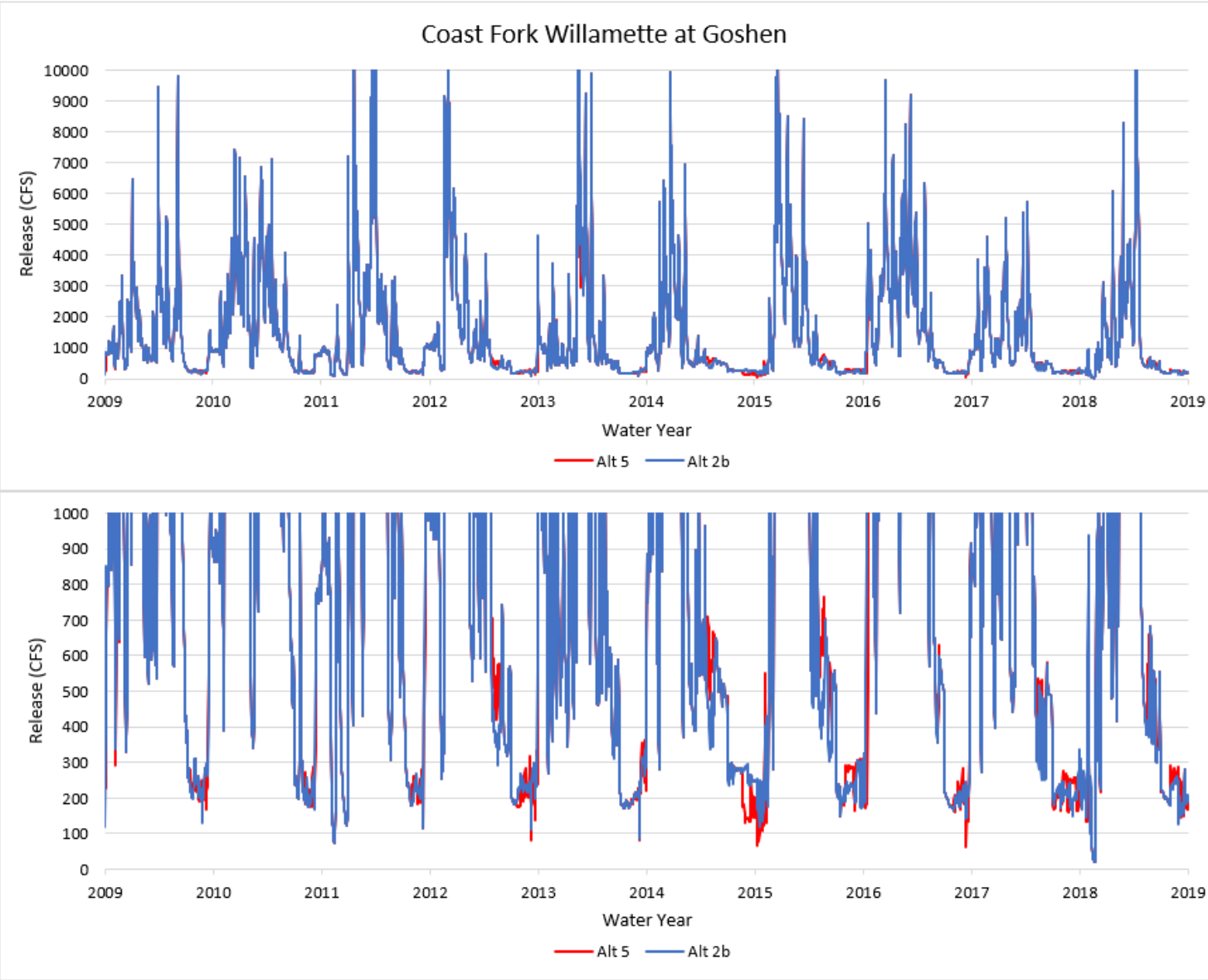

Figure 5-266. Goshen Alternatives 5/2B WY 2009–2019 Plot.

Willamette Valley System Operations and Maintenance
Environmental Impact Statement

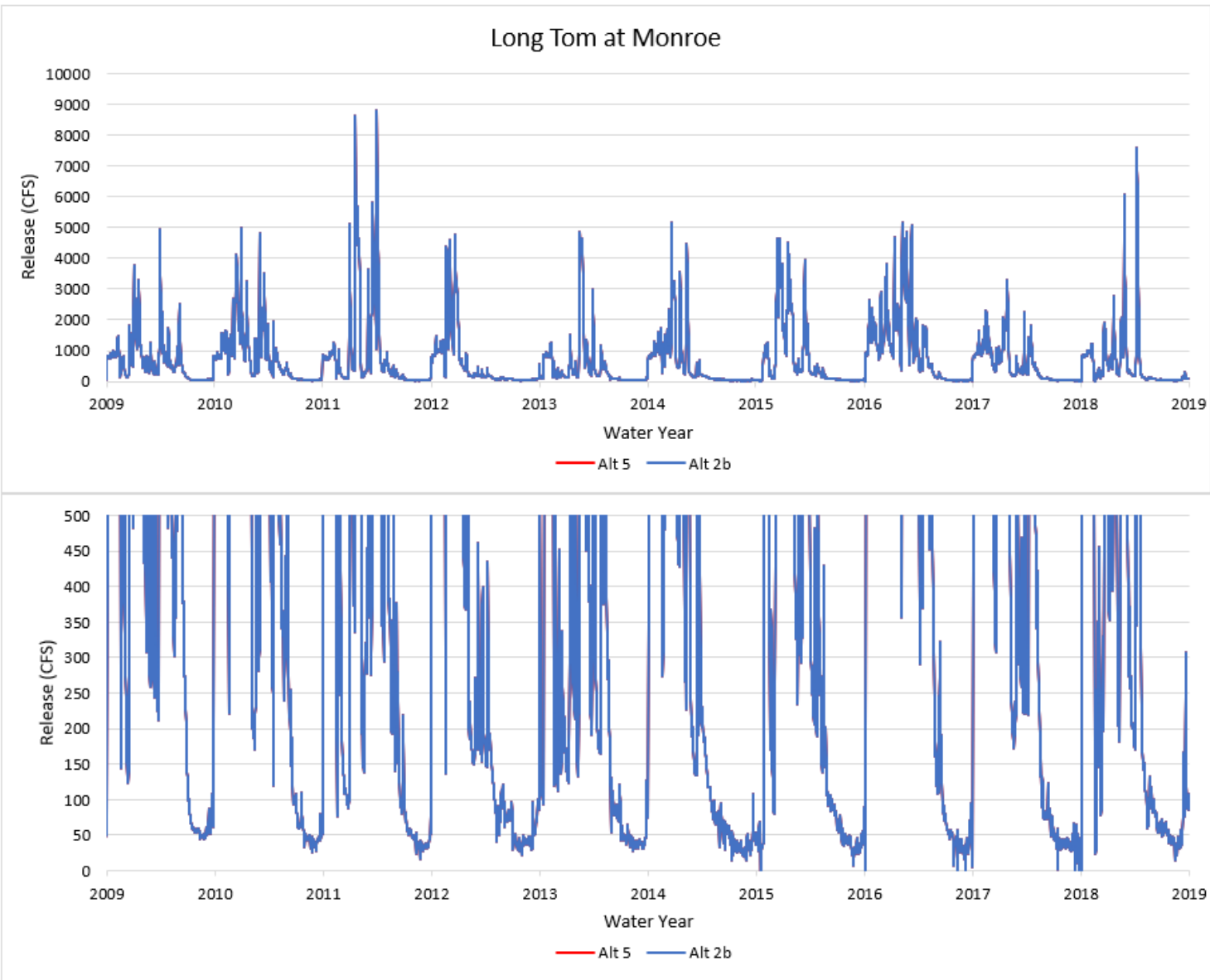

Figure 5-267. Monroe Alternatives 5/2B WY 2009–2019 Plot.

Willamette Valley System Operations and Maintenance
Environmental Impact Statement

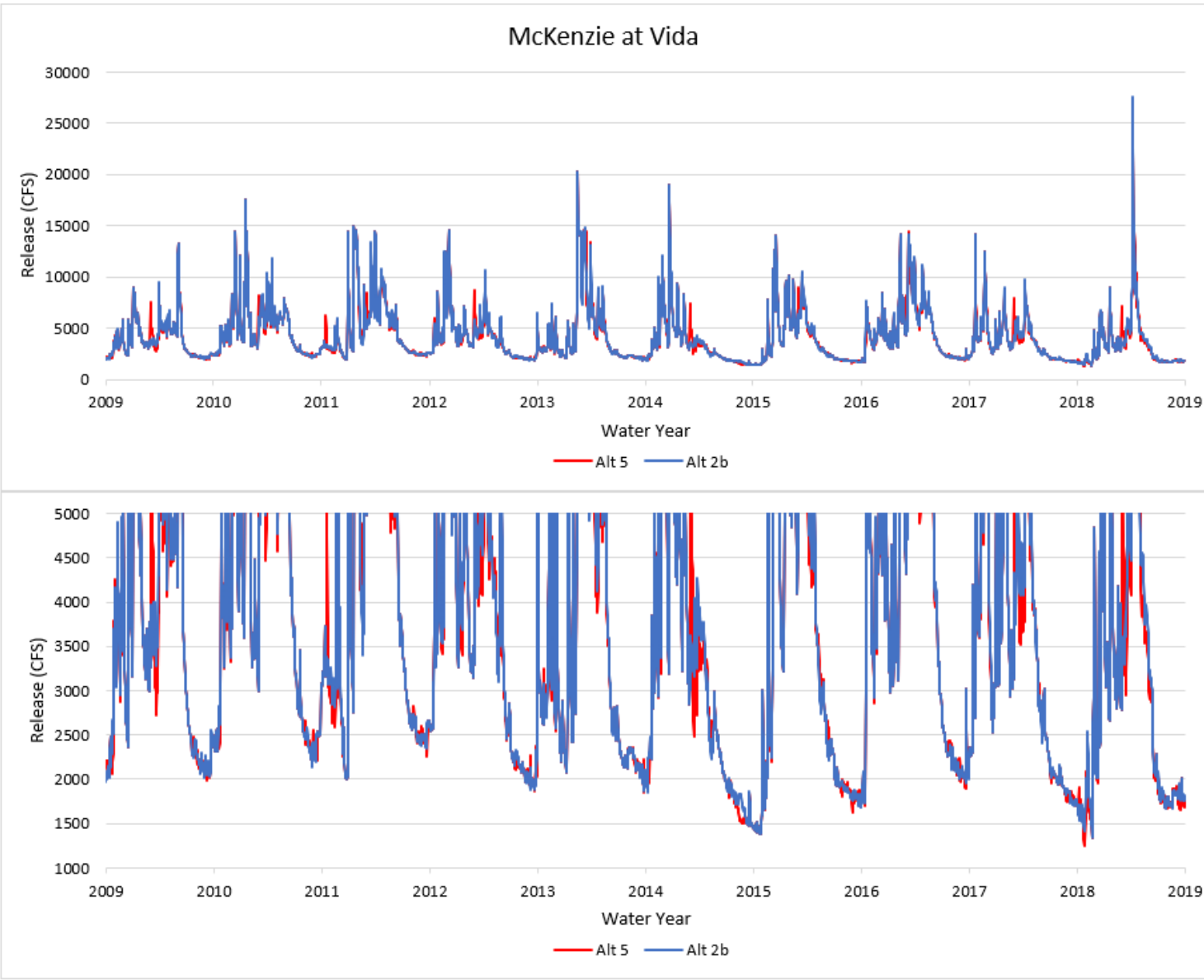

Figure 5-268. Vida Alternatives 5/2B WY 2009–2019 Plot.

*Willamette Valley System Operations and Maintenance
Environmental Impact Statement*

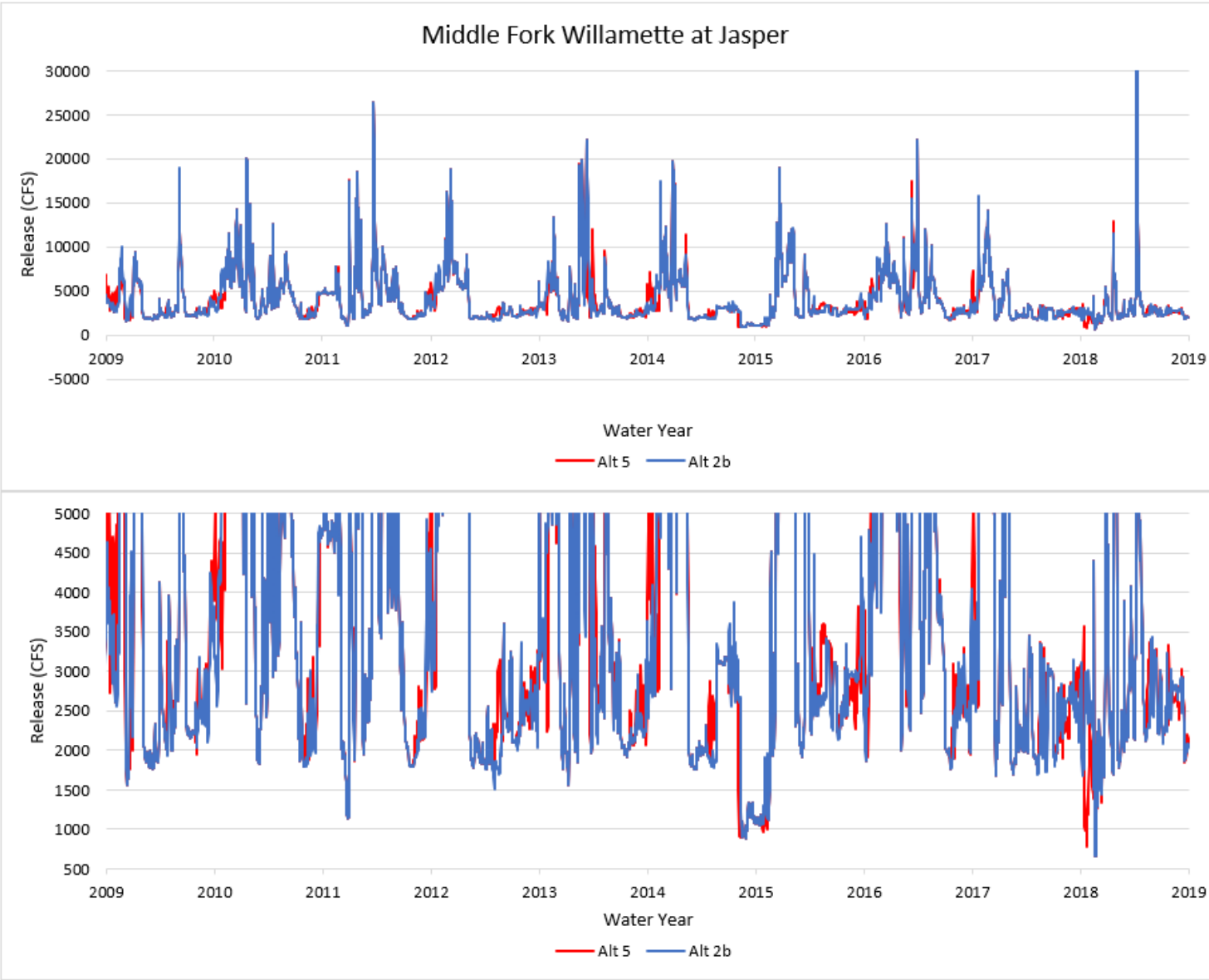

Figure 5-269. Jasper Alternatives 5/2B WY 2009–2019 Plot.

Willamette Valley System Operations and Maintenance
Environmental Impact Statement

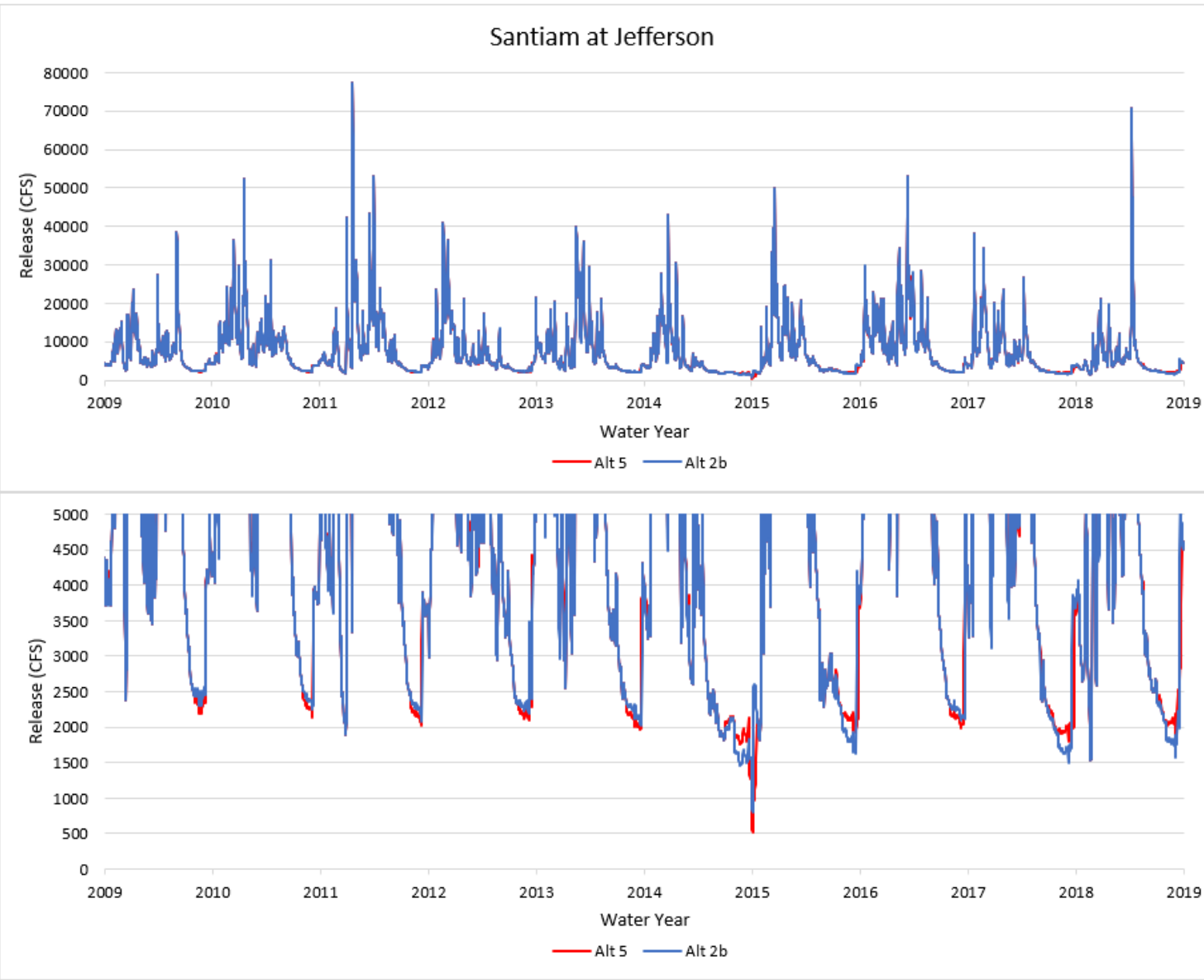

Figure 5-270. Jefferson Alternatives 5/2B WY 2009–2019 Plot.

Willamette Valley System Operations and Maintenance
Environmental Impact Statement

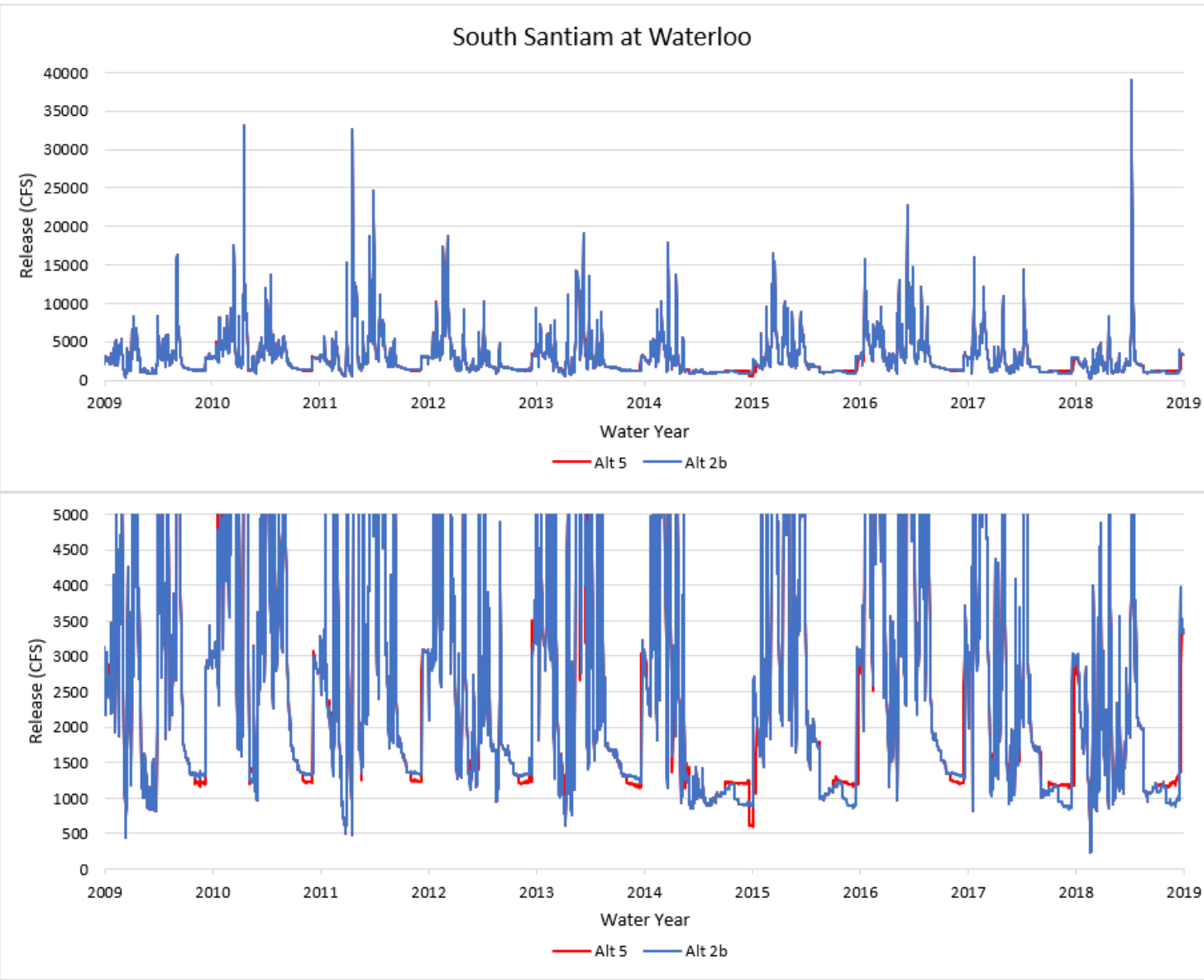

Figure 5-271. Waterloo Alternatives 5/2B WY 2009–2019 Plot.

Willamette Valley System Operations and Maintenance
Environmental Impact Statement

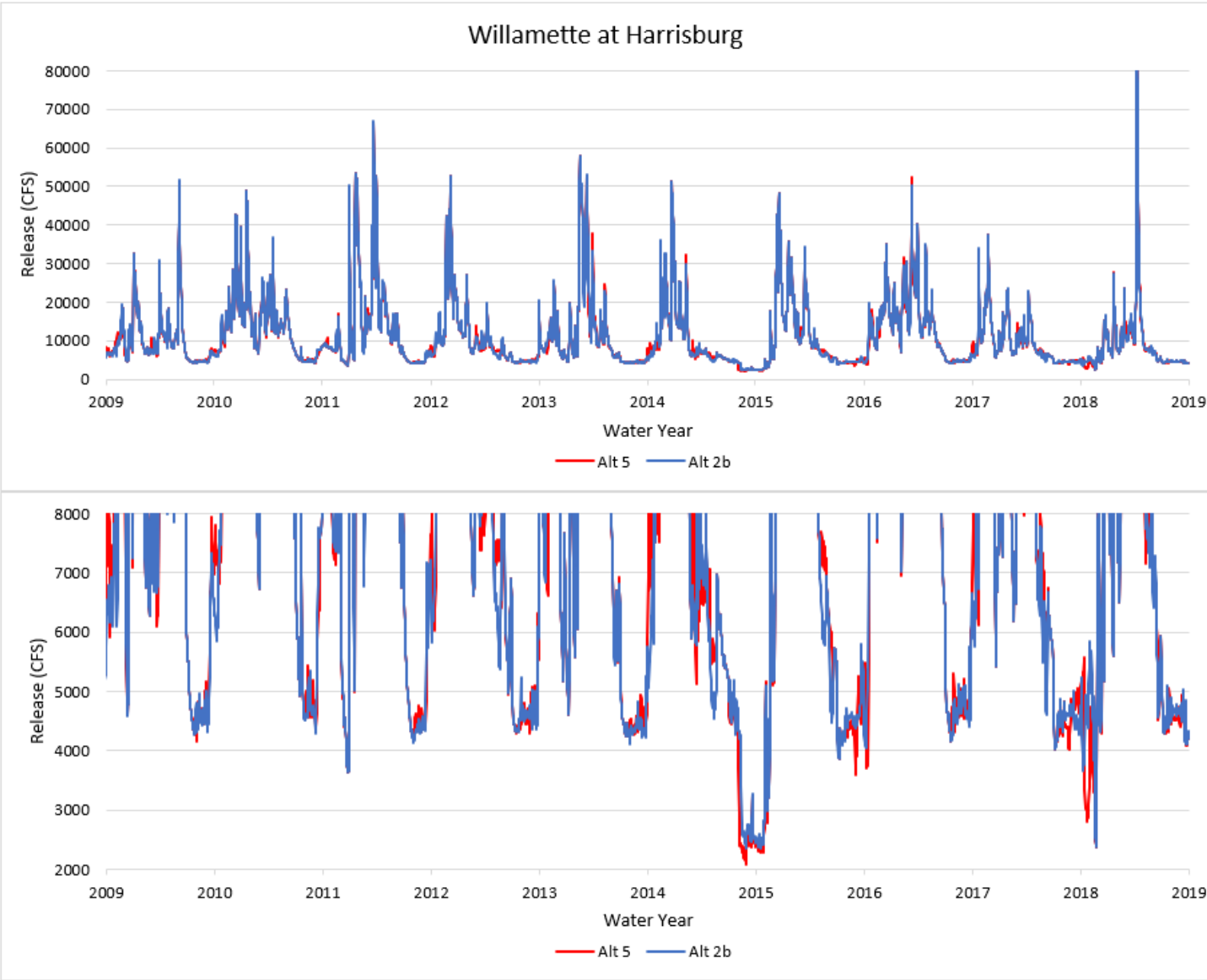

Figure 5-272. Harrisburg Alternatives 5/2B WY 2009–2019 Plot.

Willamette Valley System Operations and Maintenance
Environmental Impact Statement

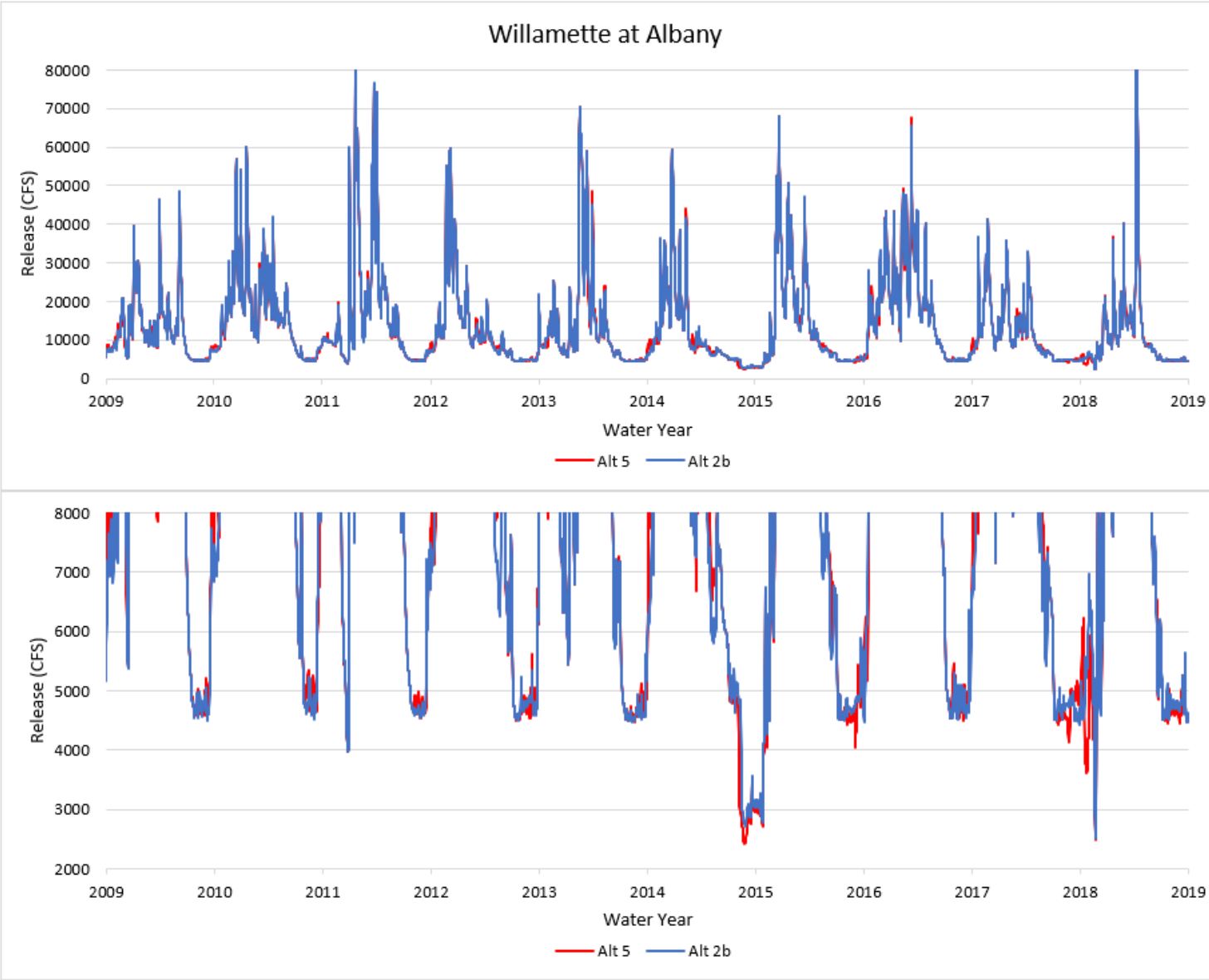

Figure 5-273. Albany Alternatives 5/2B WY 2009–2019 Plot.

Willamette Valley System Operations and Maintenance
Environmental Impact Statement

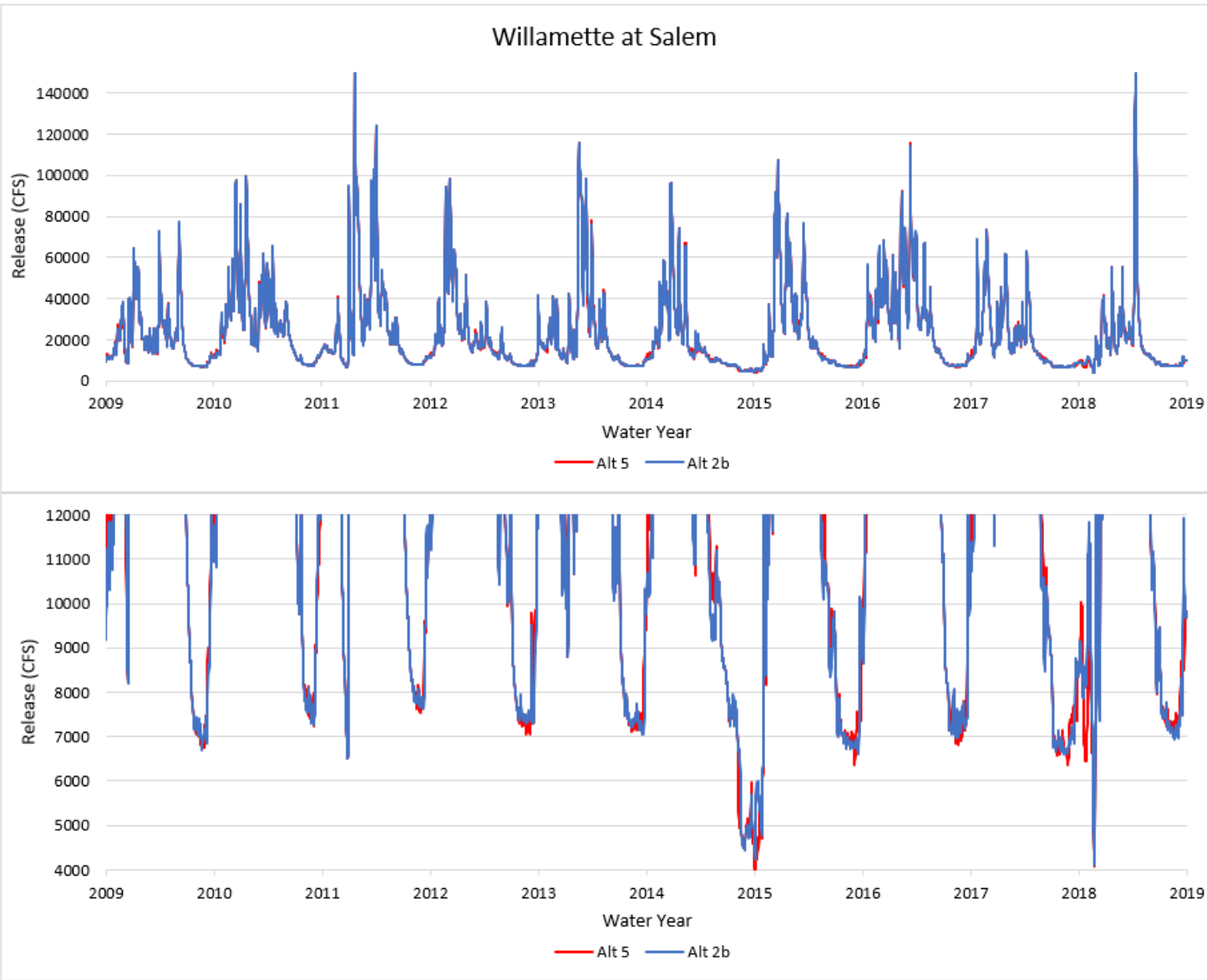

Figure 5-274. Salem Alternatives 5/2B WY 2009–2019 Plot.

6 QUALITATIVE ASSESSMENT OF CLIMATE CHANGE IMPACTS TO HYDROLOGY

Climate change impacts, and methodology and assumptions below, draw on the climate change projection and trend information provided in the climate change appendices (F1 and F2).

This is a qualitative assessment of the effects of climate change on the water surface elevation in the WVS reservoirs (“storage”) and the total downstream flow including unregulated flow (“flow”) at each listed control point. The primary inputs to the assessment are the storage and flow summary non-exceedance figures (Section 5) and climate change ‘natural flow’ box and whisker plots broken out by month (Figure 6-1 to Figure 6-12). Additional information came from the precipitation projections and HEC-DSS HEC-ResSim outputs, though these were used less frequently.

Each alternative is compared to itself in the climate change assessment. The central question is, “how would the projected flow changes affect the alternative baseline?” Furthermore, it is not appropriate to compare across alternatives with these determinations. Each alternative has a unique set of operational measures, and this qualitative analysis shows how those modeled operations would behave under altered conditions due to climate change, such as more rainfall in place of snow and drier summers. In other words, a descriptor (“Less”) is used to describe the change in the expected storage or flow, not the quantity of storage or flow. Two alternatives may have the same type of change and descriptor but different expected quantities since the alternative baseline is different. This analysis is not complete without the use of the hydrologic analysis (Section 3.2) and summary figures.

Section 3.2, Hydrologic Processes, of the WVS FEIS contains the qualitative engineering analysis based on these determinations, under the climate change section of each alternative. Section 4.2, Hydrologic Processes, includes climate change as an RFFA as part of the cumulative effects analysis of the WVS.

The hydrology climate change assessment is divided by WVS reservoirs and the downstream control points. Each location and alternative, including the NAA, has a projection of the climate change effects. These qualitative descriptions are “Much More”, “More”, “Similar”, “Less”, and “Much Less.” The descriptions are based on engineering judgment and generally a descriptor of the percent difference for the alternative under climate change. The “Much More” and “Much Less” descriptors are typically reserved for flow or storage conditions that are likely outside the period-of-record modeled results. For example, if a reservoir would typically exhaust its stored water in an alternative to meet downstream flow targets, less total summer flow (both into the reservoir and local flow downstream) would make this happen earlier in the year or a lower minimum flow, described here as “Much Less.” If the reservoir would likely have some additional capacity to augment flow despite these same climactic flow reductions (in other words, some stored water remains in the modeled alternative), the descriptor is instead “Less.”

*Willamette Valley System Operations and Maintenance
Environmental Impact Statement*

A few basic assumptions:

- Flow attenuates and accumulates as it goes downstream. In other words, as the river moves away from a dam, flow changes will become milder unless the input flows are similarly affected.
- Downstream flow targets are prioritized over reservoir storage. If a reservoir has storage available under an alternative, it will use it to meet downstream flow targets even if it requires a significant drop in reservoir storage.
- Reservoirs that already draft to a minimum elevation under an alternative would not alter their operations earlier in the year within each alternative framework to store more water prior to the summer.
- Winter includes November through February.
- Spring includes February through May. The overlap with winter is necessary as the WVS reservoirs start filling in February and the month is a significant factor in whether the system reaches maximum conservation pool or not.
- Summer includes June through October.
- Each determination is for all water year types. Changes to exceedance lines are generally compared to the like box and whisker plot (i.e., the P05 line in the non-exceedance figures is more heavily influenced by the P10 plot than the P90 plot).
- Because there is an upper limit to summer storage (maximum conservation pool) where additional inflow does not increase available storage later in the year, drier years often control the determination even if wetter years would be similar between the baseline and climate projection. Because wetter years may be similar and drier years would be drier, the overall determination would be “Less” or “Much Less.”

Winter flow volumes are projected to increase for most of the WVS. Although the HEC-ResSim model is not a flood operations model, the volume that each project regulates during the winter is approximately correct. If the baseline exceedance figures show that the reservoir is regularly nearly the top of available storage, additional releases would be required with the greater flow projected. Reservoirs that stay lower in the baseline have more freedom to increase storage during the winter and keep regulated downstream flows similar.

Cougar, Detroit, and Hills Creek Reservoirs are particularly affected by the larger volume and conversion from snow to rainfall due to their higher average basin elevation (see Figure 6-2, Figure 6-4, and Figure 6-9, respectively). Hills Creek Reservoir generally stays somewhat lower during the winter than these other two reservoirs, so it would be able to manage that additional flow somewhat. However, as with most reservoirs in the WVS, winter flow is expected to increase regardless. The reservoirs only control a portion of the basin and increased precipitation will affect the uncontrolled areas as well.

Spring flow volumes are projected to be similar in the climate change projections for the WVS, but flows will likely be distributed earlier in the year. February and March are projected to have higher flows, whereas lower flows are projected in April and May. The determinations use a combination the filling season of each reservoir, the percentage of time it fills in the baseline, and its sensitivity to generally earlier flows. The spring season is often a matter of engineering judgment.

A spring drawdown (or delayed refill, depending on the alternative and reservoir) would have the largest effect on storage. Because inflow is projected to occur earlier in the year and fall off more steeply into late spring and early summer, these operations would increasingly prevent the WVS reservoir from storing water. The downstream flow targets also influence the drier years of each alternative since these targets are a higher percentage of the total flow in those years. Even local flows often meet some flow targets in average and wetter years without augmentation from stored water.

Summer flow volumes are projected to decrease for most of the WVS, with particularly big changes in higher elevation basins with more snow melt, such as Detroit and Cougar Reservoirs. Reservoirs will have to release more water to meet downstream flow targets as local inflows will be less. If reservoirs have stored water available in the baseline alternative, they will try to meet downstream flow targets. It is difficult to project if or when a particular reservoir would run out of stored water.

The summer storage and flow determinations are typically an interaction of the specific spring drawdowns (or delayed refill) in an alternative and the selected set of flow targets at downstream locations. Of course, other operations affect the peak storage at each WVS reservoir, but the assumptions built into those two operations have the largest effect. As the year goes on and generally drier conditions prevail, a greater proportion of the water at most flow target locations comes from water stored earlier in the year. Therefore, lower peak storage (say, from lower total inflow) at an earlier date (for example, from a shift of flow to early spring) will result in less storage and flow downstream throughout the summer.

Additional information under each alternative is provided below. Although the operation set is different across the alternatives, the same climate change scenario applies to the following information.

6.1 No-action Alternative

The No-action Alternative (NAA) uses the Biological Opinion (NMFS 2008) flow targets downstream of the WVS reservoirs. Two of the basins, Detroit and Cougar Reservoirs, most affected by the decreasing flow during the late spring and summer would already occasionally hit their minimum elevation prior the draft in preparation for winter. Because all WVS reservoirs and local flow in unregulated basins would be similarly affected, summer flow would be less than the observed record for most locations. Table 6-1 shows the climate determinations under the NAA.

*Willamette Valley System Operations and Maintenance
Environmental Impact Statement*

Table 6-1. Storage and Differences due to Climate Change under the NAA.

Storage	WVS Reservoir	Winter	Spring	Summer
Santiam	Detroit	Much More	Similar	Much Less
	Green Peter	More	Similar	Less
	Foster	More	Similar	Less
Long Tom	Fern Ridge	Similar	Similar	Similar
McKenzie	Blue River	More	Less	Less
	Cougar	Much More	Less	Much Less
Middle Fork	Hills Creek	More	Similar	Less
	Lookout Point	More	Similar	Less
	Fall Creek	More	Less	Less
Coast Fork	Dorena	More	Similar	Similar
	Cottage Grove	More	Similar	Similar
Flow	Location	Winter	Spring	Summer
Santiam	Detroit	Much More	Similar	Less
	Mehama	Much More	Similar	Less
	Green Peter	Similar	Similar	Less
	Foster	More	Similar	Less
	Waterloo	More	Similar	Less
	Jefferson	More	Similar	Less
Long Tom	Fern Ridge	Similar	Similar	Similar
	Monroe	Similar	Similar	Similar
McKenzie	Blue River	Similar	Similar	Similar
	Cougar	Similar	Less	Less
	Vida	More	Less	Less
Middle Fork	Hills Creek	More	Less	Less
	Lookout Point	More	Less	Less
	Fall Creek	More	Similar	Similar
	Jasper	More	Less	Less
Coast Fork	Dorena	Similar	Similar	Similar
	Cottage Grove	Similar	Similar	Similar
	Goshen	Similar	Similar	Similar
Mainstem	Albany	More	Less	Less
	Salem	More	Similar	Less

6.2 Alternative 1

Alternative 1 uses the minimum Congressionally authorized flow targets downstream of the WVS reservoirs. These minimum flows are lower than the those in the other measures in this PEIS, so the reservoirs can store more water during the spring refill period. Therefore, the reservoirs typically supply more water later into the year and the flows downstream remain relatively unchanged. Cougar Reservoir would exhaust its supply in Alternative 1 occasionally, so the McKenzie basin sees some of that decrease and decreasing local flow would also mean

*Willamette Valley System Operations and Maintenance
Environmental Impact Statement*

decreased flow at the mainstem control points of Albany and Salem. Table 6-2 shows the climate determinations under Alternative 1.

Table 6-2. Storage and Flow Differences due to Climate Change under Alternative 1.

Storage	WVS Reservoir	Winter	Spring	Summer
Santiam	Detroit	Much More	Similar	Much Less
	Green Peter	More	Similar	Less
	Foster	More	Similar	Similar
Long Tom	Fern Ridge	Similar	Similar	Similar
McKenzie	Blue River	More	Less	Less
	Cougar	Much More	Less	Much Less
Middle Fork	Hills Creek	More	Less	Less
	Lookout Point	More	Similar	Less
	Fall Creek	More	Less	Less
Coast Fork	Dorena	More	Similar	Similar
	Cottage Grove	More	Similar	Similar
Flow	Location	Winter	Spring	Summer
Santiam	Detroit	Much More	Similar	Similar
	Mehama	Much More	Similar	Similar
	Green Peter	Similar	Similar	Similar
	Foster	More	Similar	Similar
	Waterloo	More	Similar	Similar
	Jefferson	More	Similar	Similar
Long Tom	Fern Ridge	Similar	Similar	Similar
	Monroe	Similar	Similar	Similar
McKenzie	Blue River	Similar	Similar	Similar
	Cougar	Similar	Less	Less
	Vida	More	Less	Less
Middle Fork	Hills Creek	More	Less	Less
	Lookout Point	More	Similar	Similar
	Fall Creek	More	Similar	Similar
	Jasper	More	Less	Less
Coast Fork	Dorena	Similar	Similar	Similar
	Cottage Grove	Similar	Similar	Similar
	Goshen	Similar	Similar	Similar
Mainstem	Albany	More	Similar	Less
	Salem	More	Similar	Less

6.3 Alternative 2A

Green Peter Reservoir would have a fall drawdown in Alternative 2A and refilling from the lower minimum elevation would take most of the winter. In the meantime, there would be

*Willamette Valley System Operations and Maintenance
Environmental Impact Statement*

additional storage to absorb some inflow, reducing total outflow volume during the flood season.

The integrated temperature and habitat flow regime would enable the WVS to store more water in the spring. Hills Creek Dam and Reservoir would often be supplying the water to control temperature under the flow measure, so it runs out of water sometimes, along with Detroit and Cougar Dams and Reservoirs due to their higher average basin elevation (leading to decreasing flows). Overall downstream flows would be less, but not drastically so due to the extra water stored and operations to draft below minimum conservation pool (e.g., Hills Creek Dam and Reservoir). Table 6-3 shows the climate determinations under Alternative 2A.

Table 6-3. Storage and Flow Differences due to Climate Change for Alternative 2A.

Storage	WVS Reservoir	Winter	Spring	Summer
Santiam	Detroit	Much More	Similar	Much Less
	Green Peter	More	Similar	Less
	Foster	More	Similar	Similar
Long Tom	Fern Ridge	Similar	Similar	Similar
McKenzie	Blue River	More	Less	Less
	Cougar	Much More	Less	Much Less
Middle Fork	Hills Creek	More	Less	Much Less
	Lookout Point	More	Similar	Less
	Fall Creek	More	Less	Less
Coast Fork	Dorena	More	Similar	Similar
	Cottage Grove	More	Similar	Similar
Flow	Location	Winter	Spring	Summer
Santiam	Detroit	Much More	Similar	Less
	Mehama	Much More	Similar	Less
	Green Peter	Similar	Similar	Similar
	Foster	Similar	Similar	Similar
	Waterloo	Similar	Similar	Similar
	Jefferson	More	Similar	Less
	Long Tom	Fern Ridge	Similar	Similar
	Monroe	Similar	Similar	Similar
McKenzie	Blue River	Similar	Similar	Similar
	Cougar	Similar	Less	Less
	Vida	More	Less	Less
Middle Fork	Hills Creek	More	Less	Less
	Lookout Point	More	Similar	Similar
	Fall Creek	More	Similar	Similar
	Jasper	More	Less	Less
Coast Fork	Dorena	Similar	Similar	Similar
	Cottage Grove	Similar	Similar	Similar
	Goshen	Similar	Similar	Similar

*Willamette Valley System Operations and Maintenance
Environmental Impact Statement*

Storage	WVS Reservoir	Winter	Spring	Summer
Mainstem	Albany	More	Similar	Less
	Salem	More	Similar	Less

6.4 Alternative 2B

The only operational change from Alternative 2A within Alternative 2B is the drawdowns to the diversion tunnel elevation at Cougar Reservoir. This occurs during the spring and fall. Like Green Peter Dam and Reservoir, Cougar Reservoir would have some extra storage space into the winter after the fall drawdown, wet years would return Cougar Reservoir to minimum conservation pretty quickly. Blue River Dam and Reservoir would have to hold more water in late winter as Cougar Dam and Reservoir starts its spring drawdown because the two reservoirs share the control point at Vida.

Although the integrated temperature and habitat flow regime would initially allow some WVS reservoirs to store additional water as compared to the Biological Opinion (NMFS 2008), the loss of storage at Cougar Dam and Reservoir would place additional requirements on the system. Hills Creek and Lookout Point Dams and Reservoirs would reach their minimum elevations more frequently as their own basins see decreasing summer flows and as they would be required to additional supply water downstream to make up for lack of Cougar Dam and Reservoir storage. The areas directly downstream of these reservoirs would be most affected by the changes. Table 6-4 shows the climate determinations under Alternative 2B.

*Willamette Valley System Operations and Maintenance
Environmental Impact Statement*

Table 6-4. Storage and Flow Differences due to Climate Change for Alternative 2B.

Storage	WVS Reservoir	Winter	Spring	Summer
Santiam	Detroit	Much More	Similar	Much Less
	Green Peter	More	Similar	Less
	Foster	More	Similar	Similar
Long Tom	Fern Ridge	Similar	Similar	Similar
McKenzie	Blue River	More	Less	Less
	Cougar	Much More	Less	Much Less
Middle Fork	Hills Creek	More	Less	Much Less
	Lookout Point	More	Similar	Much Less
	Fall Creek	More	Less	Less
Coast Fork	Dorena	More	Similar	Similar
	Cottage Grove	More	Similar	Similar
Flow	Location	Winter	Spring	Summer
Santiam	Detroit	Much More	Similar	Less
	Mehama	Much More	Similar	Less
	Green Peter	Similar	Similar	Similar
	Foster	Similar	Similar	Similar
	Waterloo	Similar	Similar	Similar
	Jefferson	More	Similar	Less
Long Tom	Fern Ridge	Similar	Similar	Similar
	Monroe	Similar	Similar	Similar
McKenzie	Blue River	More	Similar	Less
	Cougar	Similar	Less	Much Less
	Vida	More	Less	Much Less
Middle Fork	Hills Creek	More	Less	Less
	Lookout Point	More	Similar	Less
	Fall Creek	More	Similar	Similar
	Jasper	More	Less	Less
Coast Fork	Dorena	Similar	Similar	Similar
	Cottage Grove	Similar	Similar	Similar
	Goshen	Similar	Similar	Similar
Mainstem	Albany	More	Similar	Less
	Salem	More	Similar	Less

6.5 Alternative 3A

The fall drawdowns at six reservoirs would mean there is more storage volume available heading into winter. Downstream flows would see similar volumes to the baseline as the reservoirs are brought back to minimum conservation elevation.

During spring the entire system will store less water due to the spring drawdowns, also affecting how water is stored in other reservoirs, such as Hills Creek (because it is in series with Lookout Point Dam and Reservoir). However, a similar amount of water would be stored in the

*Willamette Valley System Operations and Maintenance
Environmental Impact Statement*

model versus the climate change scenario. Even if the amount of water changes, the operation determines the storage and even drastically reduced inflow would not change the pool elevation at the end of the spring drawdowns.

The modeled results show that Alternative 3A would often not meet its downstream flow targets, whether directly downstream of the WVS dams (e.g., Mehama downstream of Detroit Dam and Reservoir) or the mainstem targets. These misses would increase in frequency to the point that some targets may be possible to achieve only in notably wet years. Table 6-5 shows the climate determinations under Alternative 3A.

Table 6-5. Storage and Flow Differences due to Climate Change for Alternative 3A.

Storage	WVS Reservoir	Winter	Spring	Summer
Santiam	Detroit	More	Similar	Less
	Green Peter	More	Similar	Less
	Foster	More	Similar	Similar
Long Tom	Fern Ridge	Similar	Similar	Similar
McKenzie	Blue River	More	Less	Less
	Cougar	Much More	Similar	Much Less
Middle Fork	Hills Creek	More	Much Less	Much Less
	Lookout Point	More	Similar	Much Less
	Fall Creek	More	Less	Less
Coast Fork	Dorena	More	Similar	Similar
	Cottage Grove	More	Similar	Similar
Flow	Location	Winter	Spring	Summer
Santiam	Detroit	Similar	Similar	Much Less
	Mehama	More	Similar	Much Less
	Green Peter	Similar	Similar	Similar
	Foster	Similar	Similar	Similar
	Waterloo	Similar	Similar	Similar
	Jefferson	More	Similar	Less
Long Tom	Fern Ridge	Similar	Similar	Similar
	Monroe	Similar	Similar	Similar
McKenzie	Blue River	Similar	Similar	Much Less
	Cougar	Similar	Less	Much Less
	Vida	More	Less	Much Less
Middle Fork	Hills Creek	More	Less	Much Less
	Lookout Point	Similar	Similar	Much Less
	Fall Creek	More	Similar	Similar
	Jasper	More	Similar	Much Less
Coast Fork	Dorena	Similar	Similar	Similar
	Cottage Grove	Similar	Similar	Similar
	Goshen	Similar	Similar	Similar
Mainstem	Albany	More	Similar	Much Less

*Willamette Valley System Operations and Maintenance
Environmental Impact Statement*

Storage	WVS Reservoir	Winter	Spring	Summer
	Salem	More	Similar	Much Less

6.6 Alternative 3B

The fall drawdowns at six reservoirs would mean there is more storage volume available heading into winter. Downstream flows would see similar volumes to the baseline as the reservoirs are brought back to minimum conservation elevation.

During the spring drawdown at Hills Creek Reservoir, water will be released into Lookout Point Dam and Reservoir. The additional expected flow from the higher elevation basin will make its way to Lookout Point Dam and Reservoir and further downstream during wetter years if the reservoir is already at its rule curve.

The spring drawdowns under Alternative 3B are at Hills Creek, Green Peter, and Cougar Dams and Reservoirs. The Hills Creek Dam and Reservoir water would be somewhat captured by Lookout Point Dam and Reservoir, and the Green Peter Dam and Reservoir basin is projected to be somewhat less affected by climate change due to its lower average basin elevation as compared to Detroit Dam and Reservoir. This means that, while there would be more storage overall, there would still be notable effects in the areas directly downstream of certain WVS dams. Foster Dam and Reservoir would be forced to draft early in the summer in the baseline and that would happen earlier and more often as summer flow decreases and Green Peter Dam and Reservoir would not be able to resupply. The mainstem targets would be see less flow but could continue to meet the targets in 'average' years. Table 6-6 shows the climate determinations under Alternative 3B.

*Willamette Valley System Operations and Maintenance
Environmental Impact Statement*

Table 6-6. Storage and Flow Differences due to Climate Change for Alternative 3B.

Storage	WVS Reservoir	Winter	Spring	Summer
Santiam	Detroit	More	Similar	Much Less
	Green Peter	More	Similar	Much Less
	Foster	More	Similar	Much Less
Long Tom	Fern Ridge	Similar	Similar	Similar
McKenzie	Blue River	More	Less	Less
	Cougar	Much More	Less	Much Less
Middle Fork	Hills Creek	More	Similar	Much Less
	Lookout Point	More	More	Less
	Fall Creek	More	Less	Less
Coast Fork	Dorena	More	Similar	Similar
	Cottage Grove	More	Similar	Similar
Flow	Location	Winter	Spring	Summer
Santiam	Detroit	Similar	Similar	Less
	Mehama	More	Similar	Less
	Green Peter	Similar	Similar	Much Less
	Foster	Similar	Similar	Much Less
	Waterloo	Similar	Similar	Much Less
	Jefferson	More	Similar	Less
Long Tom	Fern Ridge	Similar	Similar	Similar
	Monroe	Similar	Similar	Similar
McKenzie	Blue River	Similar	Similar	Much Less
	Cougar	Similar	Less	Much Less
	Vida	More	Less	Much Less
Middle Fork	Hills Creek	More	More	Much Less
	Lookout Point	Similar	More	Less
	Fall Creek	More	Similar	Similar
	Jasper	More	Similar	Less
Coast Fork	Dorena	Similar	Similar	Similar
	Cottage Grove	Similar	Similar	Similar
	Goshen	Similar	Similar	Similar
Mainstem	Albany	More	Similar	Less
	Salem	More	Similar	Less

6.7 Alternative 4

The primary driver of storage and flow within Alternative 4 is the integrated temperature and flow regime targets. Because Alternative 4 relies on structures rather than operations to provide fish passage, the other notable drivers of storage and flow are not present. Even so, storing additional water over the Biological Opinion (NMFS 2008) flow targets cannot change that summers will be drier more often. Table 6-7 shows the climate determinations under Alternative 4.

*Willamette Valley System Operations and Maintenance
Environmental Impact Statement*

Table 6-7. Storage and Flow Differences due to Climate Change under Alternative 4.

Storage	WVS Reservoir	Winter	Spring	Summer
Santiam	Detroit	Much More	Similar	Much Less
	Green Peter	More	Similar	Less
	Foster	More	Similar	Similar
Long Tom	Fern Ridge	Similar	Similar	Similar
McKenzie	Blue River	More	Less	Less
	Cougar	Much More	Less	Much Less
Middle Fork	Hills Creek	More	Less	Much Less
	Lookout Point	More	Similar	Less
	Fall Creek	More	Less	Less
Coast Fork	Dorena	More	Similar	Similar
	Cottage Grove	More	Similar	Similar
Flow	Location	Winter	Spring	Summer
Santiam	Detroit	Much More	Similar	Less
	Mehama	Much More	Similar	Less
	Green Peter	Similar	Similar	Less
	Foster	More	Similar	Similar
	Waterloo	More	Similar	Similar
	Jefferson	More	Similar	Less
Long Tom	Fern Ridge	Similar	Similar	Similar
	Monroe	Similar	Similar	Similar
McKenzie	Blue River	Similar	Similar	Similar
	Cougar	Similar	Less	Less
	Vida	More	Less	Less
Middle Fork	Hills Creek	More	Less	Less
	Lookout Point	More	Similar	Similar
	Fall Creek	More	Similar	Similar
	Jasper	More	Less	Less
Coast Fork	Dorena	Similar	Similar	Similar
	Cottage Grove	Similar	Similar	Similar
	Goshen	Similar	Similar	Similar
Mainstem	Albany	More	Similar	Less
	Salem	More	Similar	Less

6.8 Alternative 5

Green Peter and Cougar Dams and Reservoirs would have some extra storage space into the winter after the fall drawdown, wet years would return Cougar to minimum conservation pretty quickly. Blue River Dam and Reservoir would have to hold more water in late winter as Cougar Dam and Reservoir starts its spring drawdown because the two reservoirs share the control point at Vida.

*Willamette Valley System Operations and Maintenance
Environmental Impact Statement*

Alternative 5 is similar to Alternative 2B with the modified integrated temperature and flow regime targets, which are somewhat higher in some locations compared to the unmodified (Alternative 2B) set. Although the modified flow targets would initially allow some WVS reservoir to store additional water as compared to the Biological Opinion targets (NMFS 2008), the loss of storage at Cougar Dam and Reservoir would place additional requirements on the system. Hills Creek and Lookout Point Dams and Reservoirs would reach their minimum elevations more frequently as their own basins see decreasing summer flows and as they would be required to additional supply water downstream to make up for lack of Cougar Dam and Reservoir storage. The driest years would see the most impact and the areas directly downstream of these reservoirs would be most affected by the changes. Table 6-8 shows the climate determinations under Alternative 5.

Table 6-8. Storage and Flow Differences due to Climate Change under Alternative 5.

Storage	WVS Reservoir	Winter	Spring	Summer
Santiam	Detroit	Much More	Similar	Much Less
	Green Peter	More	Similar	Less
	Foster	More	Similar	Similar
Long Tom	Fern Ridge	Similar	Similar	Similar
McKenzie	Blue River	More	Less	Less
	Cougar	Much More	Less	Much Less
Middle Fork	Hills Creek	More	Less	Much Less
	Lookout Point	More	Similar	Much Less
	Fall Creek	More	Less	Less
Coast Fork	Dorena	More	Similar	Similar
	Cottage Grove	More	Similar	Similar
Flow	Location	Winter	Spring	Summer
Santiam	Detroit	Much More	Similar	Less
	Mehama	Much More	Similar	Less
	Green Peter	Similar	Similar	Similar
	Foster	Similar	Similar	Similar
	Waterloo	Similar	Similar	Similar
	Jefferson	More	Similar	Less
Long Tom	Fern Ridge	Similar	Similar	Similar
	Monroe	Similar	Similar	Similar
McKenzie	Blue River	More	Similar	Less
	Cougar	Similar	Less	Much Less
	Vida	More	Less	Much Less
Middle Fork	Hills Creek	More	Less	Less
	Lookout Point	More	Similar	Less
	Fall Creek	More	Similar	Similar
	Jasper	More	Less	Less
Coast Fork	Dorena	Similar	Similar	Similar
	Cottage Grove	Similar	Similar	Similar

*Willamette Valley System Operations and Maintenance
Environmental Impact Statement*

Storage	WVS Reservoir	Winter	Spring	Summer
	Goshen	Similar	Similar	Similar
Mainstem	Albany	More	Similar	Less
	Salem	More	Similar	Less

6.9 Alternative 6

Alternative 6 is identical to Alternative 5 except for the minimum tributary flow targets which adhere to the 2008 Biological Opinion targets instead of the modified integrated temperature and flow regime targets that reduce releases in the spring in years when reservoir inflows are low saving storage for releases in the summer. Mainstem flow targets are also based on the 2008 Biological Opinion designation of water year types instead of forecasted basin inflows. However, regulated hydrology is most significantly affected by the deep drawdowns at Green Peter and Cougar reservoirs. As such, Storage and Flow Differences due to Climate Change under Alternative 6 (Figure 6-9) are anticipated to be similar to Alternative 5.

Table 6-9. Storage and Flow Differences due to Climate Change under Alternative 6.

Storage	WVS Reservoir	Winter	Spring	Summer
Santiam	Detroit	Much More	Similar	Much Less
	Green Peter	More	Similar	Less
	Foster	More	Similar	Similar
Long Tom	Fern Ridge	Similar	Similar	Similar
McKenzie	Blue River	More	Less	Less
	Cougar	Much More	Less	Much Less
Middle Fork	Hills Creek	More	Less	Much Less
	Lookout Point	More	Similar	Much Less
	Fall Creek	More	Less	Less
Coast Fork	Dorena	More	Similar	Similar
	Cottage Grove	More	Similar	Similar
Flow	Location	Winter	Spring	Summer
Santiam	Detroit	Much More	Similar	Less
	Mehama	Much More	Similar	Less
	Green Peter	Similar	Similar	Similar
	Foster	Similar	Similar	Similar
	Waterloo	Similar	Similar	Similar
	Jefferson	More	Similar	Less
Long Tom	Fern Ridge	Similar	Similar	Similar
	Monroe	Similar	Similar	Similar
McKenzie	Blue River	More	Similar	Less
	Cougar	Similar	Less	Much Less
	Vida	More	Less	Much Less
Middle Fork	Hills Creek	More	Less	Less

*Willamette Valley System Operations and Maintenance
Environmental Impact Statement*

Storage	WVS Reservoir	Winter	Spring	Summer
	Lookout Point	More	Similar	Less
	Fall Creek	More	Similar	Similar
	Jasper	More	Less	Less
Coast Fork	Dorena	Similar	Similar	Similar
	Cottage Grove	Similar	Similar	Similar
	Goshen	Similar	Similar	Similar
Mainstem	Albany	More	Similar	Less
	Salem	More	Similar	Less

Willamette Valley System Operations and Maintenance
Environmental Impact Statement

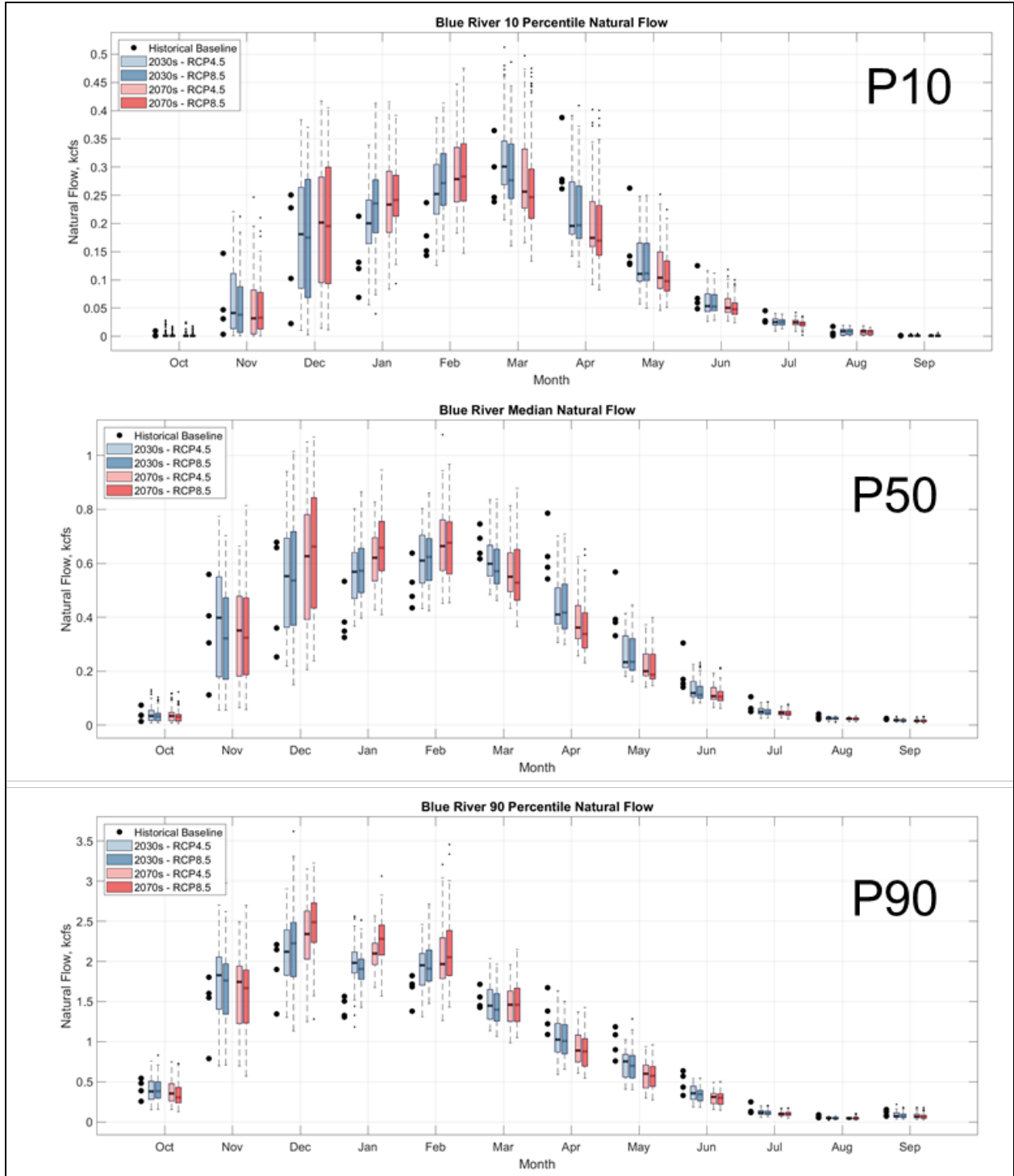

Figure 6-1. Blue River Dam and Reservoir Climate Change Projections.

Willamette Valley System Operations and Maintenance
Environmental Impact Statement

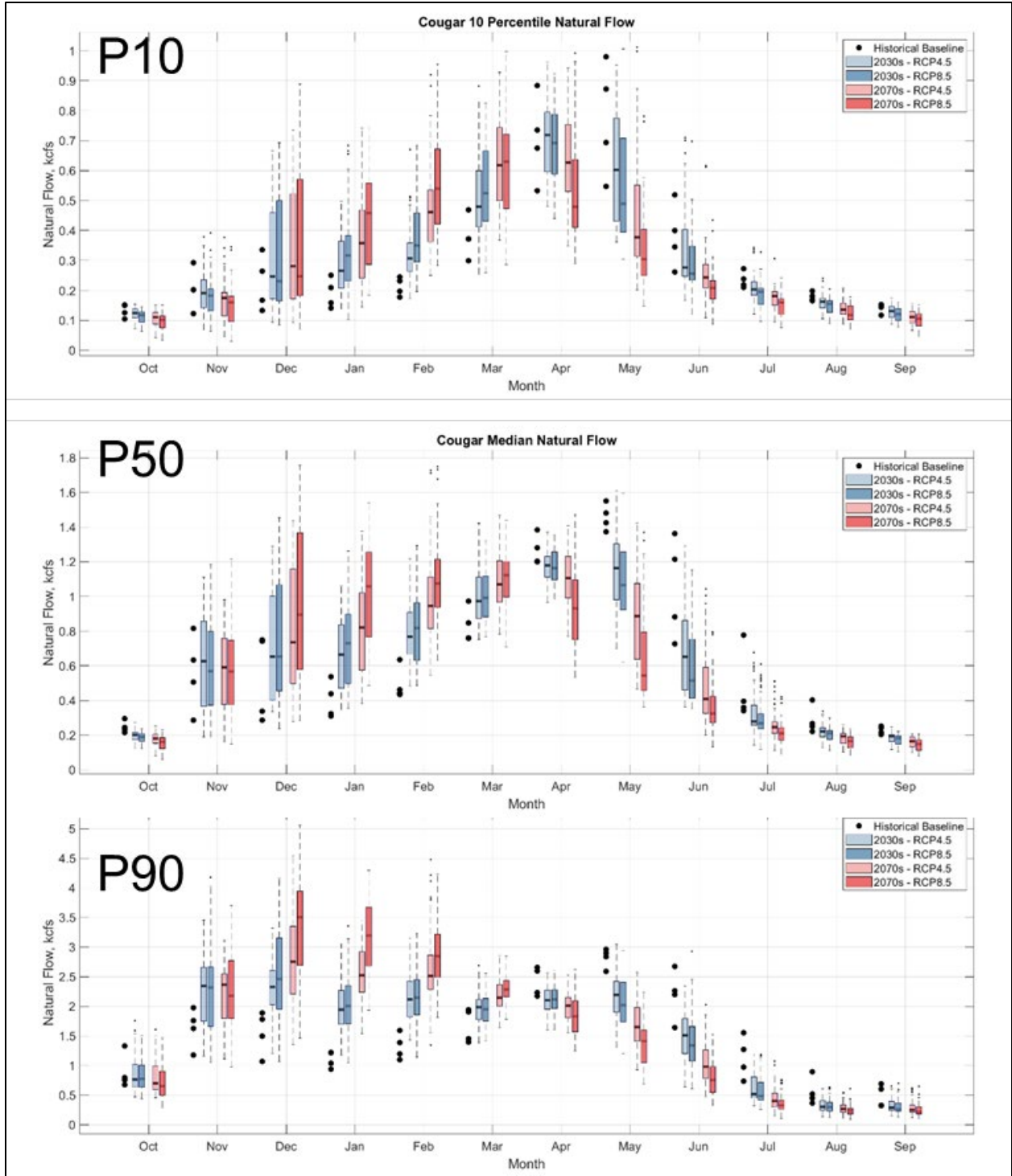

Figure 6-2. Cougar Dam and Reservoir Climate Change Projections.

Willamette Valley System Operations and Maintenance
Environmental Impact Statement

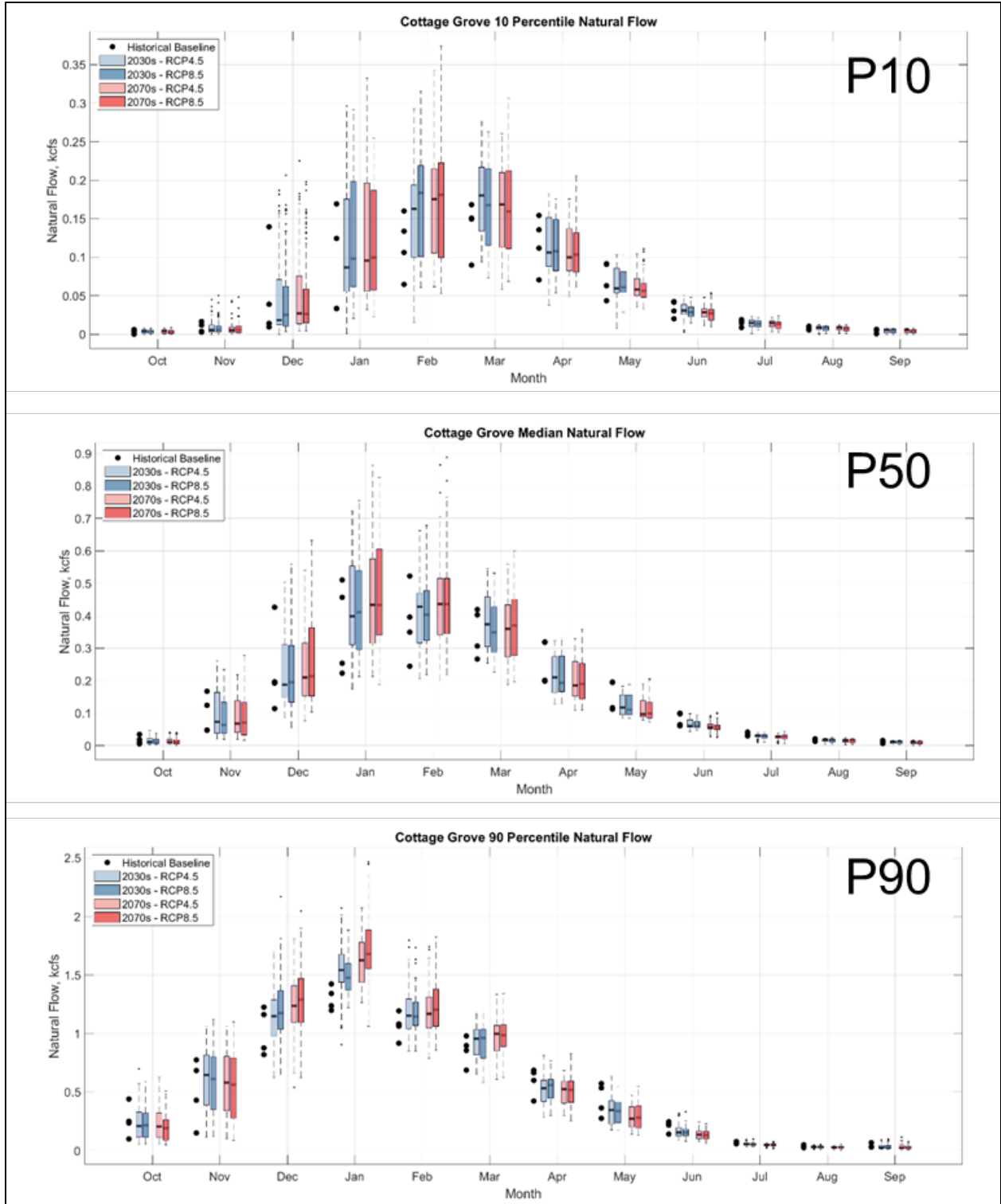

Figure 6-3. Cottage Grove Dam and Reservoir Climate Change Projections.

Willamette Valley System Operations and Maintenance
Environmental Impact Statement

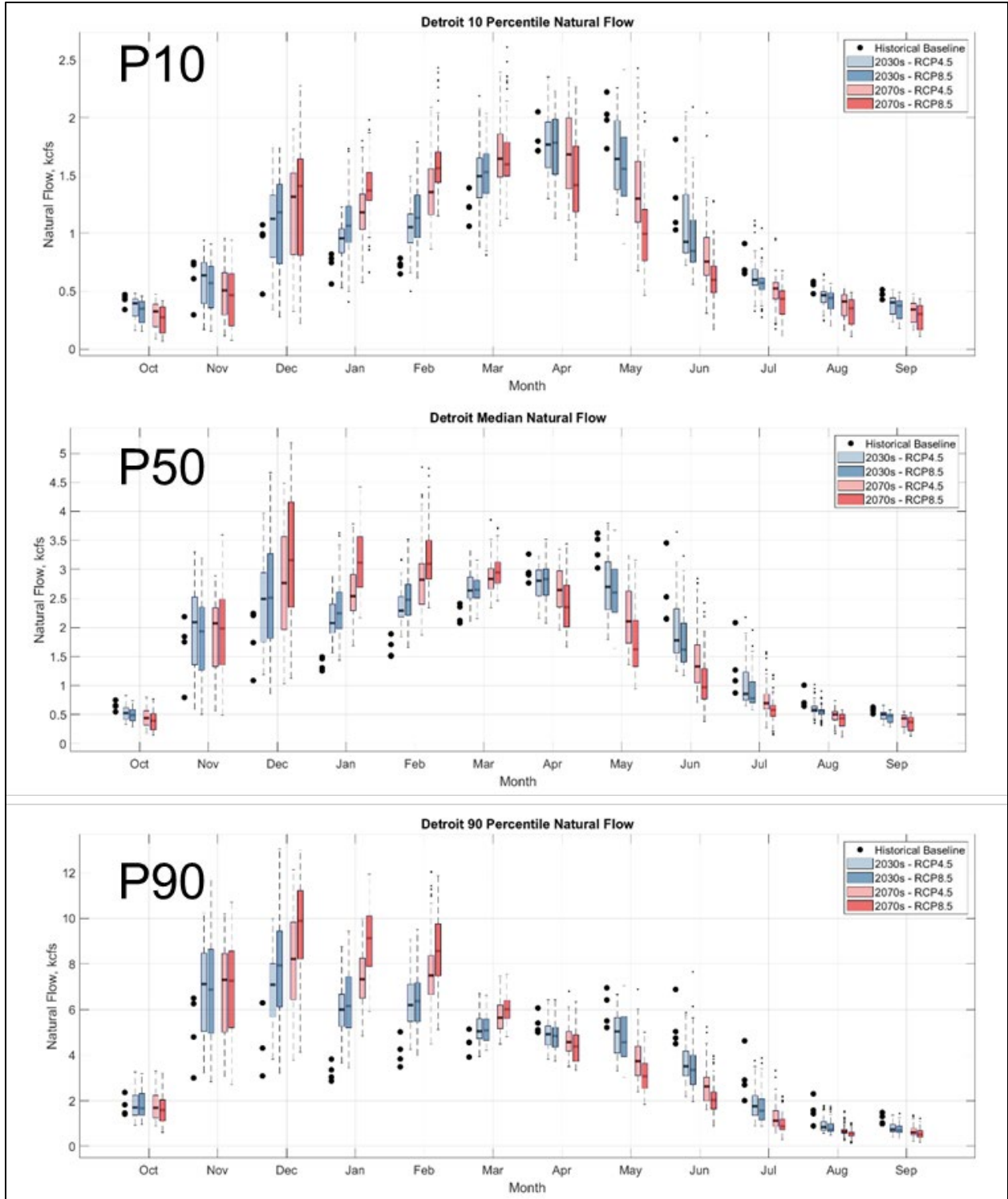

Figure 6-4. Detroit Dam and Reservoir Climate Change Projections.

Willamette Valley System Operations and Maintenance
Environmental Impact Statement

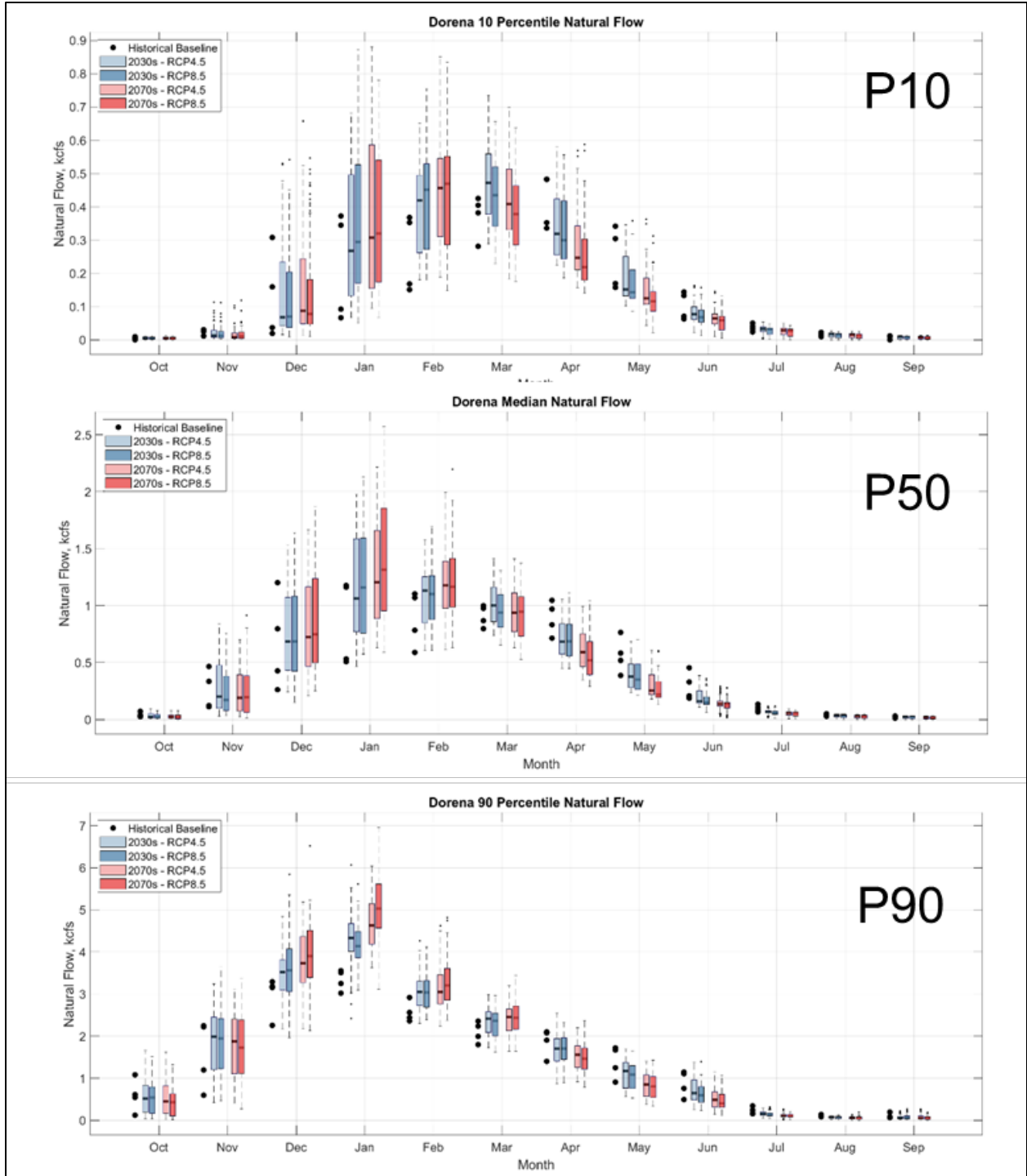

Figure 6-5. Dorena Dam and Reservoir Climate Change Projections.

Willamette Valley System Operations and Maintenance
Environmental Impact Statement

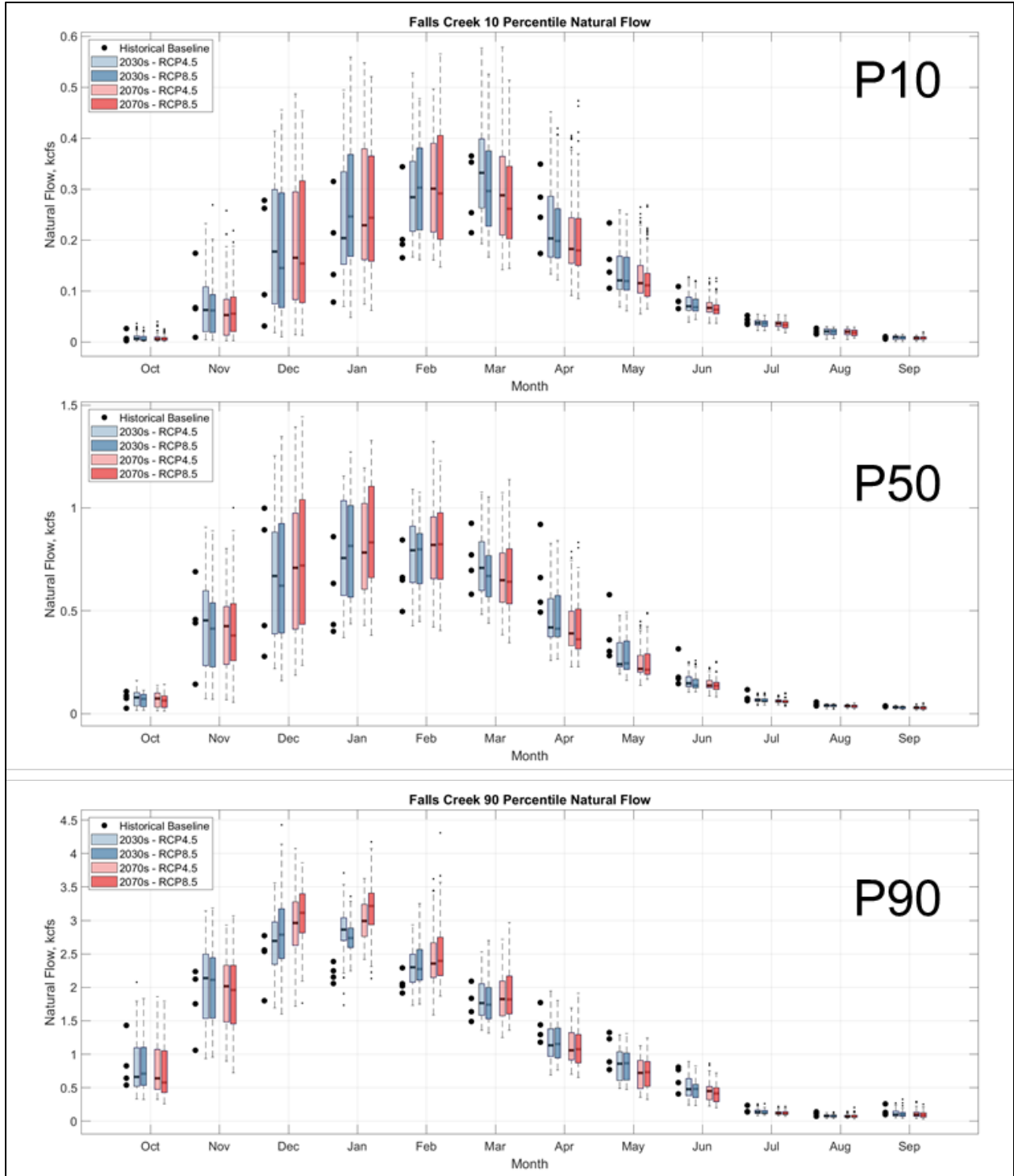

Figure 6-6. Falls Creek Dam and Reservoir Climate Change Projections.

Willamette Valley System Operations and Maintenance
Environmental Impact Statement

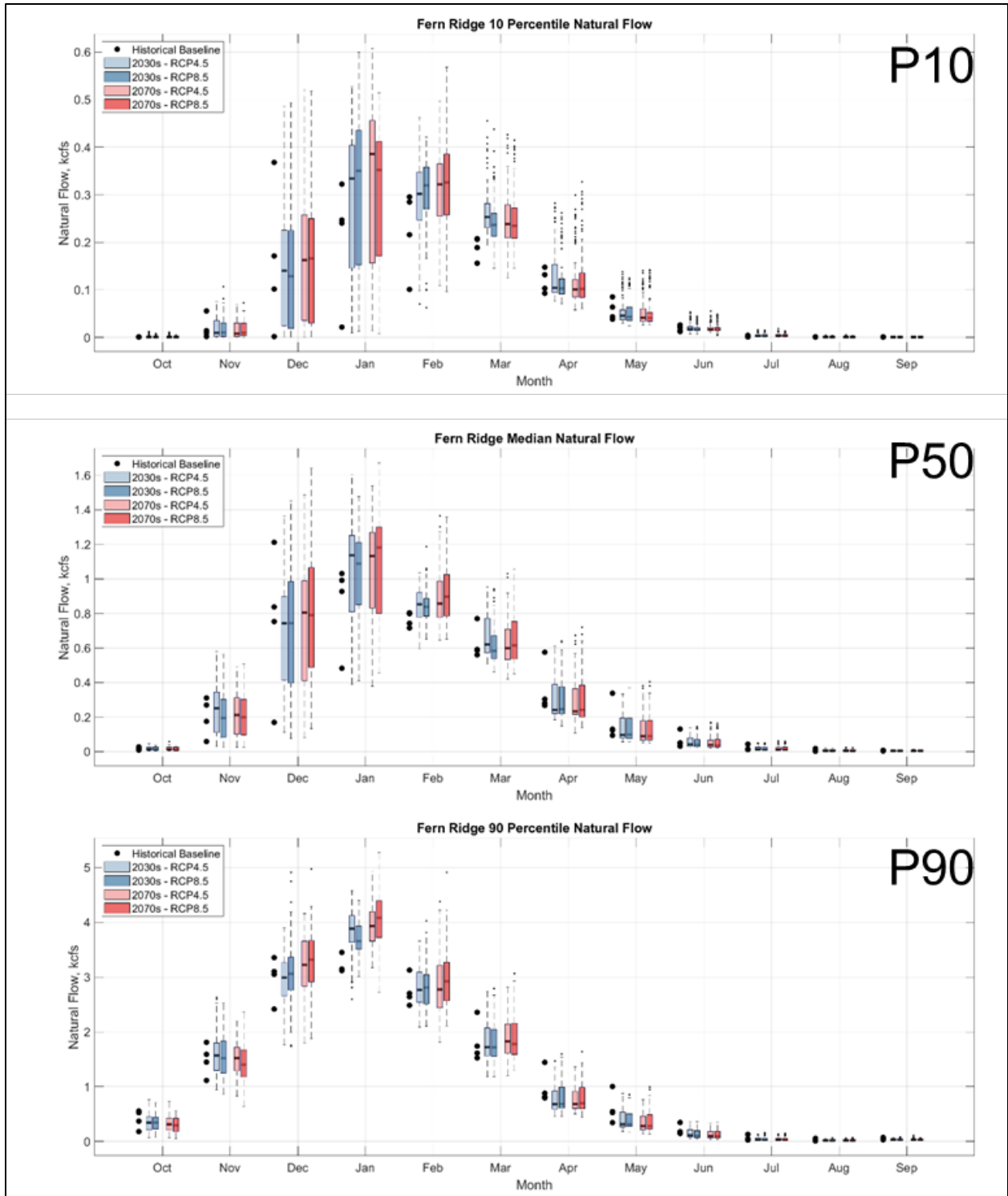

Figure 6-7. Fern Ridge Dam and Reservoir Climate Change Projections.

Willamette Valley System Operations and Maintenance
Environmental Impact Statement

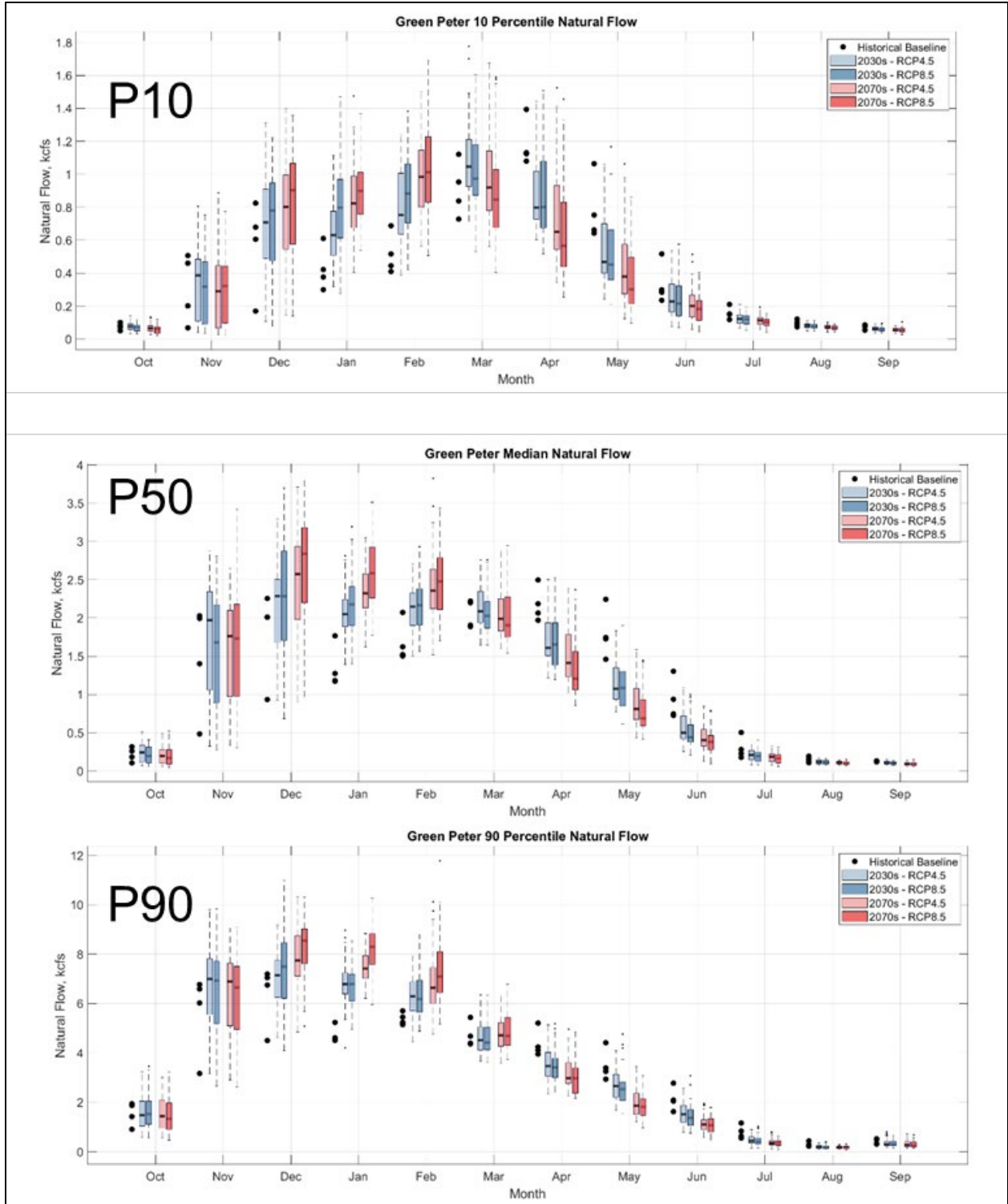

Figure 6-8. Green Peter Dam and Reservoir Climate Change Projections.

Willamette Valley System Operations and Maintenance
Environmental Impact Statement

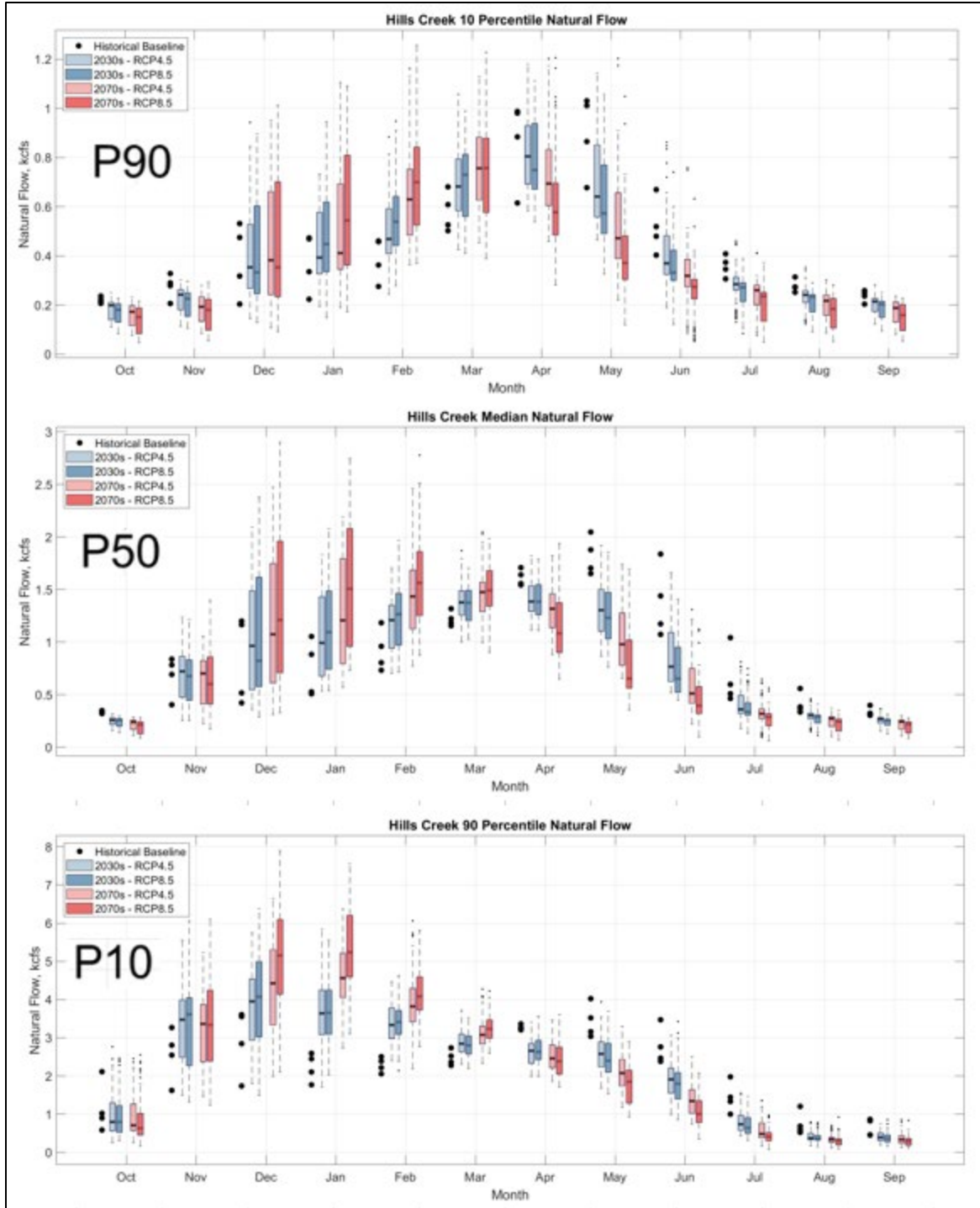

Figure 6-9. Hills Creek Dam and Reservoir Climate Change Projections.

Willamette Valley System Operations and Maintenance
Environmental Impact Statement

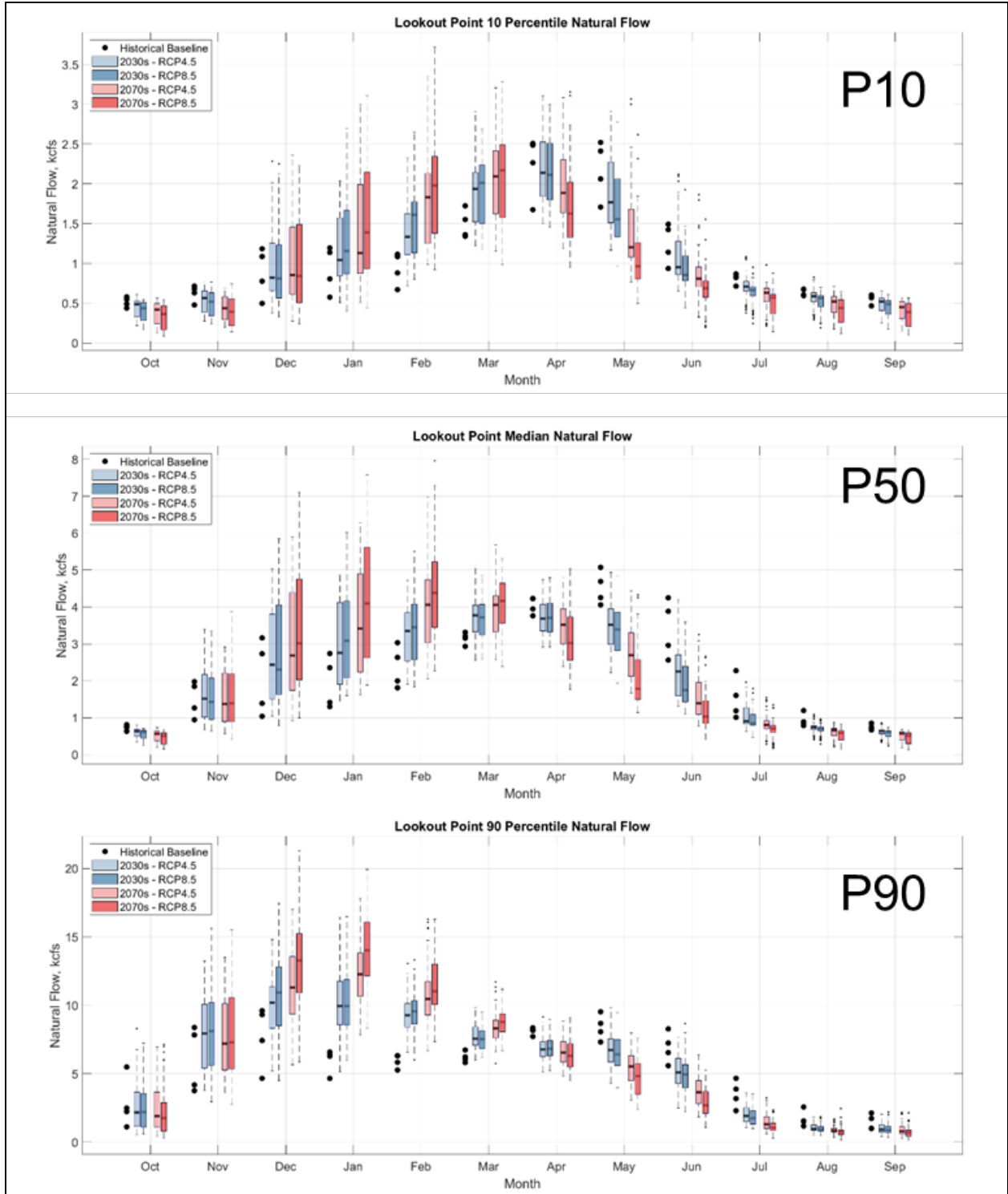

Figure 6-10. Lookout Point Dam and Reservoir Climate Change Projections.

Willamette Valley System Operations and Maintenance
Environmental Impact Statement

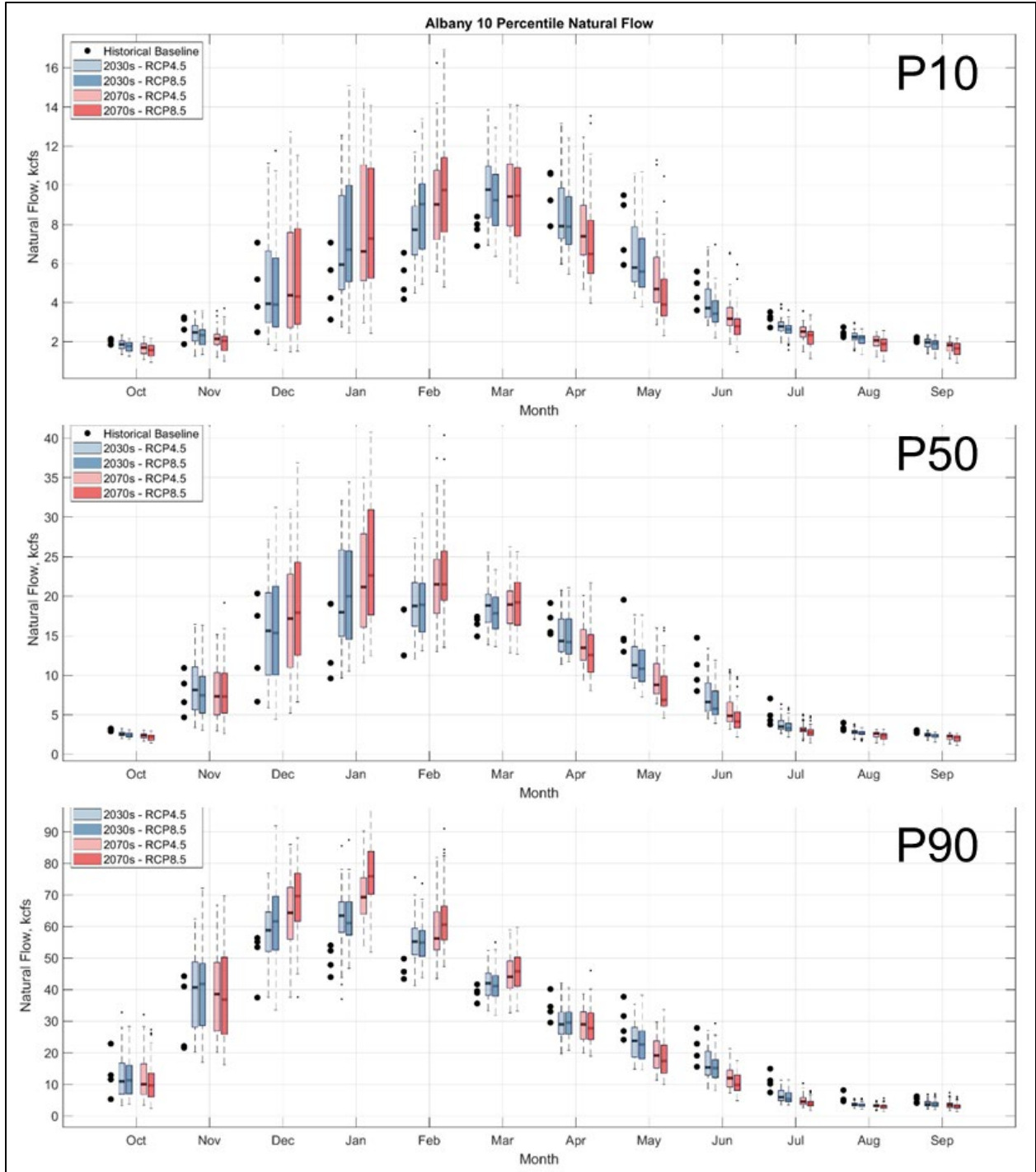

Figure 6-11. Albany Climate Change Projections.

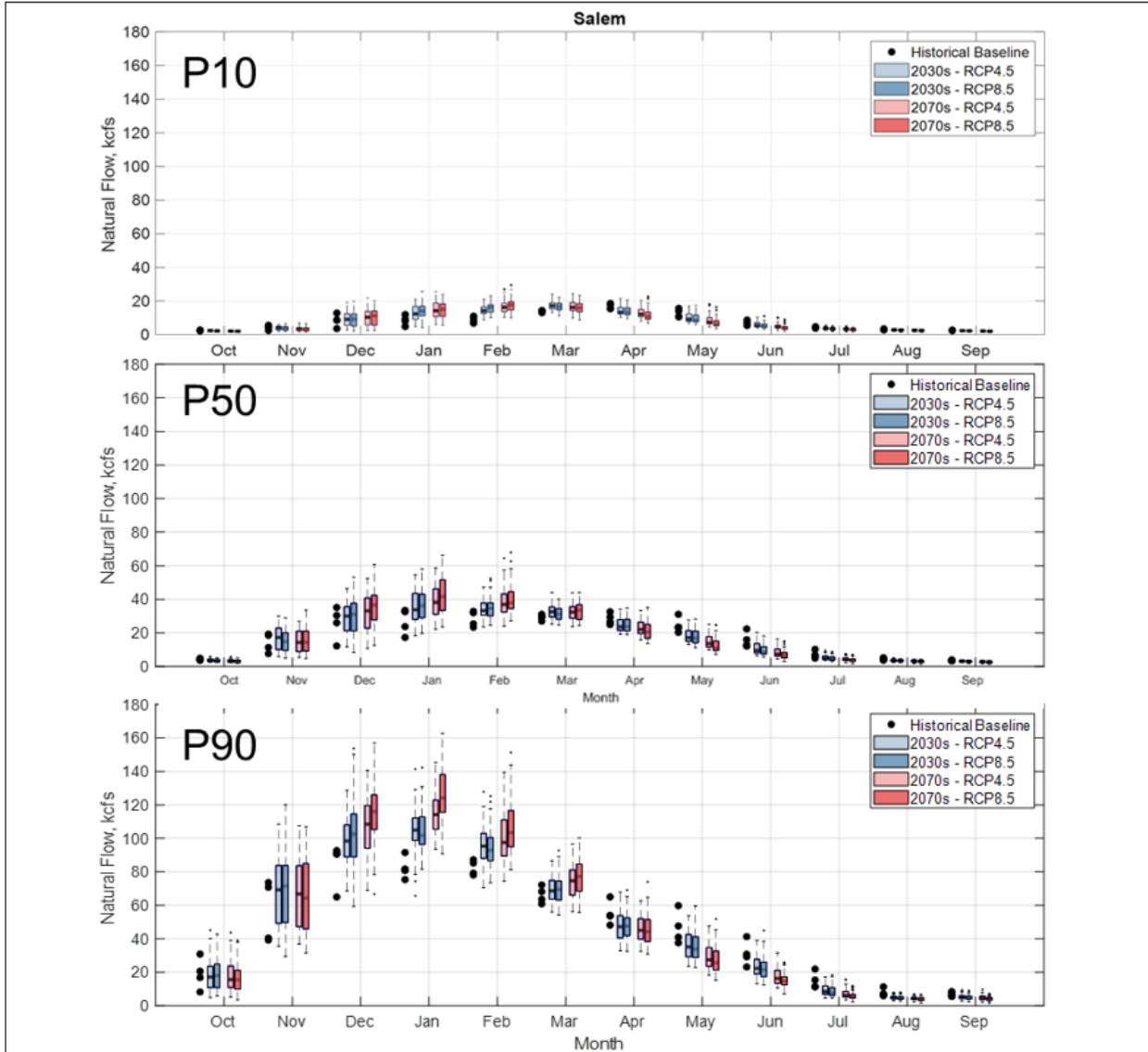

Figure 6-12. Salem Climate Change Projections.

7 INCREASE IN CONSERVATION STORAGE ASSOCIATED WITH NOT DRAWING DOWN WHEN ABOVE THE RULE CURVE FOR 14 DAYS DURING REFILL AT WVS RESERVOIRS

Allowing for storm events that raise pool levels above the rule curve during spring refill to be stored instead of drafted over a 14-day period prior to meeting the rule curve was proposed as a measure for evaluation. This analysis identifies potential increases in conservation storage associated with the proposed operation and provides rationale for the screening of this measure.

Current project constraints require WVS reservoirs to draft to the rule curve within 7 to 10 days of the flow at a downstream control point receding below regulation stage. Allowing water to

be stored above the rule curve for a longer period during spring refill, up to 14 days, offers reservoir operators even greater flexibility to store spring storm events and increase conservation season storage.

Extending the period of time pool elevations remain above the rule curve during spring refill results in prolonged periods of reduced flood storage resulting in increased flood risk. Reservoirs store water during high precipitation events to reduce flows downstream, resulting in higher pool elevations. The higher the pool elevation, the smaller rain event required to raise the pool to elevations where uncontrolled releases are required. An analysis of impacts to flood risk management (FRM) would be required if benefits to conservation storage encourage further consideration of this measure.

7.1 Methods

Increased conservation storage associated with storing water above the rule curve for 14 days following a storm event was investigated using the HEC-ResSim model. The model applies reservoir operational rules under various hydrologic conditions to simulate regulated in stream flow and reservoir elevations throughout the basin. The Willamette River Basin HEC-ResSim model includes all thirteen WVS reservoirs along with the operational rules and constraints at each location, which are designed to achieve both project-specific and system-wide objectives as specified in the project and system Water Control Manuals.

The alternative operation is modeled by creating a reservoir zone identical in slope to the rule curve that precedes the rule curve by 14 days and defining a rule in the new zone that does not permit the reservoir to draw down (Figure 7-1(a)). Reservoir elevations will only rise in this zone if inflows exceed maximum outflows which are constrained by downstream control point flows, physical outlet maximum flows, and calibration flows determined to match typical operations. When reservoir elevations rise above the new zone reservoirs will draft up to maximum flows until reaching the no drawdown zone. The No-action Alternative is similarly modeled with a 7-day period of no drawdown preceding the spring refill curve (Figure 7-1(b)).

In current operations, reservoir operators receive forecasts of future rain events. Reservoir operators will draft to the rule curve as quickly as possible after a storm event if another storm event is forecasted. HEC-ResSim does not utilize forecasting. As a result, when back-to-back events with inflows that exceed maximum outflows occur in the alternative operation, reservoir elevations may remain above the rule curve significantly longer than 14 days in the alternative simulation. As a result, observed increases in storage resulting from the alternative operation may be larger than what it would be in real time operations, particularly in adequate and abundant water years, but less so in insufficient and deficit water years which are of the greatest concern. For these reasons, increases in storage resulting from alternative operations were only reported in Insufficient and Deficit water years.

Impacts to conservation storage were evaluated by comparing the storage volume observed on the date of target maximum storage at each WVS reservoir resulting from the alternative simulation and no-action simulation in Insufficient and Deficit water years. Table 7-1 indicates

*Willamette Valley System Operations and Maintenance
Environmental Impact Statement*

the flow in cubic feet per second (cfs) that can be sustained over 30 days by releasing stored volume in increments of 1,000 acre-feet (kaf) to help contextualize the significance of increases in storage. For context, one kaf of storage can sustain releases of 17 cfs for 30 days.

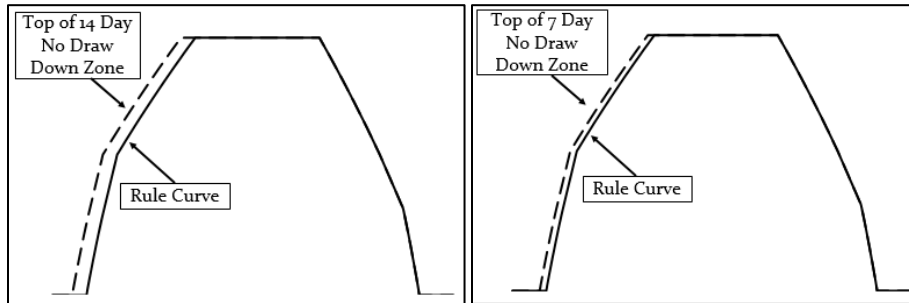

Figure 7-1. Alternative (a) and No-action (b) No Drawdown Zones.

Table 7-1. kaf Converted to cfs Sustainable over 30 Days.

1,000 Acre-Feet	cfs Sustained for 30 Days
1	17
2	34
3	50
4	67
5	84
6	101
7	117
8	134
9	151
10	168
11	184
12	201
13	218
14	235
15	252
16	268
17	285
18	302
19	319
20	335
21	352
22	369
23	386
24	402
25	419
26	436
27	453

*Willamette Valley System Operations and Maintenance
Environmental Impact Statement*

1,000 Acre-Feet	cfs Sustained for 30 Days
28	470
29	486
30	503
31	520
32	537
33	553
34	570
35	587
36	604
37	620
38	637
39	654
40	671
41	688
42	704
43	721
44	738
45	755
46	782
47	799
48	816
49	833
50	850
51	867
52	884
53	901
54	918
55	935
56	952
57	969
58	986
59	1,003
60	1,020
61	1,023
62	1,040
63	1,057
64	1,073
65	1,090
66	1,107
67	1,124
68	1,140

*Willamette Valley System Operations and Maintenance
Environmental Impact Statement*

1,000 Acre-Feet	cfs Sustained for 30 Days
69	1,157
70	1,174
71	1,191
72	1,207
73	1,224
74	1,241
75	1,258

7.2 Results and Conclusions

Table 7-2 shows increases in system conservation storage associated with the alternative operation in Insufficient and Deficit water years. Table 7-3 shows average increases at individual reservoirs. Pool elevations do not rise above the rule curve during spring refill in some Deficit water years and so benefits in those years are not realized. Increases in system storage are observed in all Insufficient water years. Tables and plots detailing increases at individual reservoirs are provided.

Table 7-2. Increases in System Conservation Storage Associated with Alternative Operations in Insufficient and Deficit Water Years.

Insufficient Year	1944	1965	1967	1968	1978	1987	1992	1994
KAF	6.4	27.5	25.3	7.2	28.3	1.0	9.7	9.2
Deficit Year	1941	1942	1973	1977	2001	2015		
KAF	7.0	0.0	56.3	0.0	1.1	6.7		

Table 7-3. Mean Increase in Conservation Storage Associated with Alternative Operations in Insufficient and Deficit Water Years.

Reservoir	Insufficient Years with Increase (of 8)	Average Increase (kaf)	Deficit Years with Increase (of 6)	Average Increase (kaf)
Blue River	1	0.2	1	0.1
Cottage Grove	2.0	0.4	1.0	0.0
Cougar	4	3.1	2	0.6
Detroit	3	2.4	2	2.2
Dorena	3	2.1	3	1.1
Fall Creek	6	2.2	4	1.9
Fern Ridge	1	1.4	0	0
Green Peter	3	0.7	2	4.8
Hills Creek	0	0	0	0
Lookout Point	2	1.9	1	1.1
System	8	14.3	4	11.9

7.3 Additional Figures and Tables

Blue River Dam and Reservoir:

Table 7-4. May Increase in Conservation Storage Associated with Alternative Operations at Blue River Dam and Reservoir in Insufficient and Deficit Years.

Insufficient Year	1944	1965	1967	1968	1978	1987	1992	1994
KAF	0.0	0.0	0.0	0.0	0.0	0.0	0.0	0.0
Deficit Year	1941	1942	1973	1977	2001	2015		
KAF	0.0	0.0	0.0	0.0	0.0	0.0		

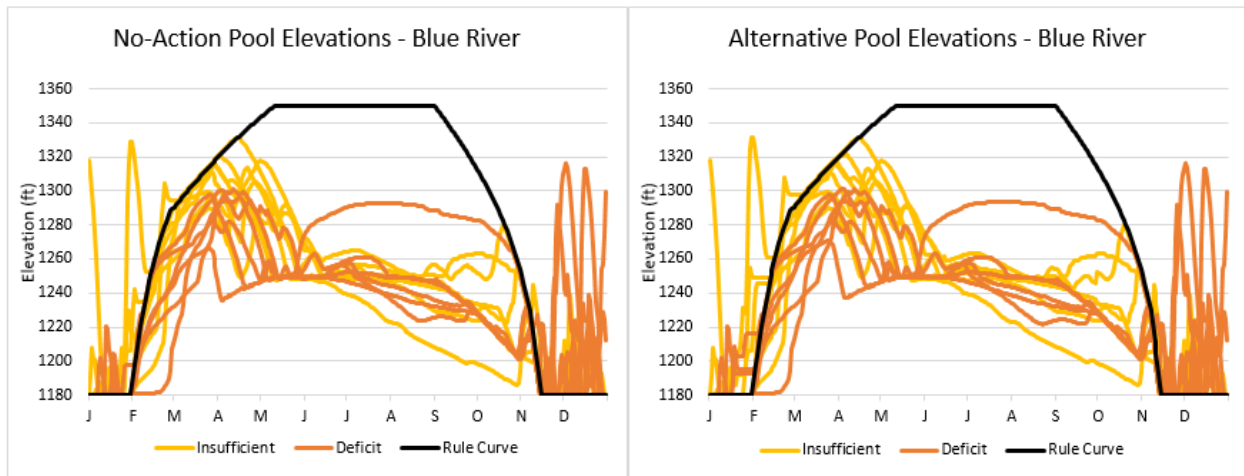

Figure 7-2. Blue River Dam and Reservoir No-action and Alternative Operations Pool Elevations in Insufficient and Deficit Water Years.

Cougar Dam and Reservoir:

Table 7-5. May Increase in Conservation Storage Associated with Alternative Operations at Cougar Dam and Reservoir Insufficient and Deficit Years.

Insufficient Year	1944	1965	1967	1968	1978	1987	1992	1994
KAF	0.0	7.9	11.9	0.0	2.0	0.0	0.0	2.6
Deficit Year	1941	1942	1973	1977	2001	2015		
KAF	0.2	0.0	3.5	0.0	0.0	0.0		

*Willamette Valley System Operations and Maintenance
Environmental Impact Statement*

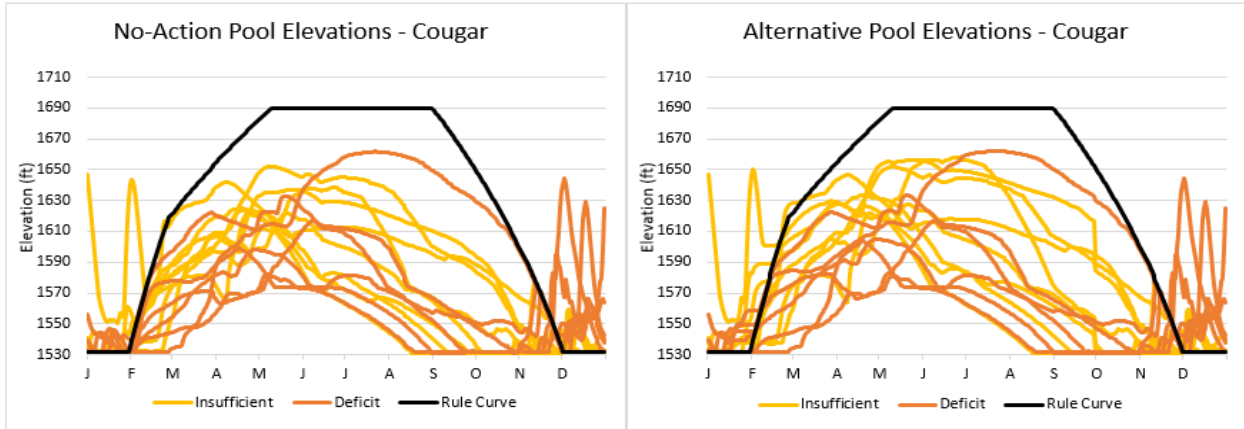

Figure 7-3. Cougar Dam and Reservoir No-action and Alternative Operations Pool Elevations in Insufficient and Deficit Water Years.

Cottage Grove Dam and Reservoir:

Table 7-6. May Increase in Conservation Storage Associated with Alternative Operations at Cottage Grove Dam and Reservoir.

Insufficient Year	1944	1965	1967	1968	1978	1987	1992	1994
KAF	1.5	0.0	Fill	0.0	0.0	0.0	0.0	1.4
Deficit Year	1941	1942	1973	1977	2001	2015		
KAF	0.0	Fill	0.0	0.0	0.0	0.1		

*Fill indicates that the reservoir filled under baseline conditions.

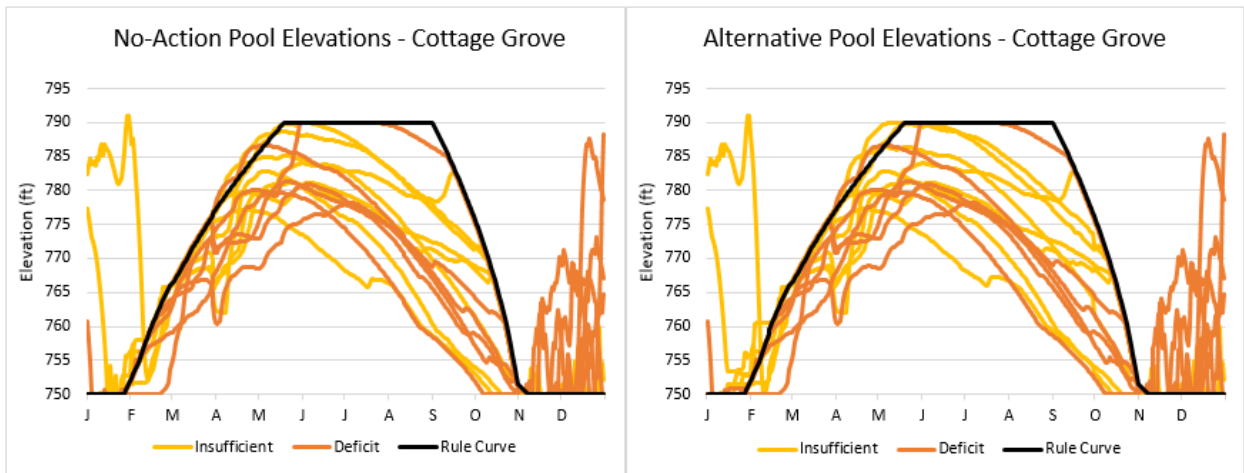

Figure 7-4. Cottage Grove Dam and Reservoir No-action and Alternative Operations Pool Elevations in Insufficient and Deficit Water Years.

*Willamette Valley System Operations and Maintenance
Environmental Impact Statement*

Detroit Dam and Reservoir:

Table 7-7. May Increase in Conservation Storage Associated with Alternative Operations at Detroit Dam and Reservoir.

Insufficient Year	1944	1965	1967	1968	1978	1987	1992	1994
KAF	0.0	3.9	11.6	3.6	0.0	0.0	0.0	0.0
Deficit Year	1941	1942	1973	1977	2001	2015		
KAF	0.3	0.0	12.8	0.0	0.0	0.0		

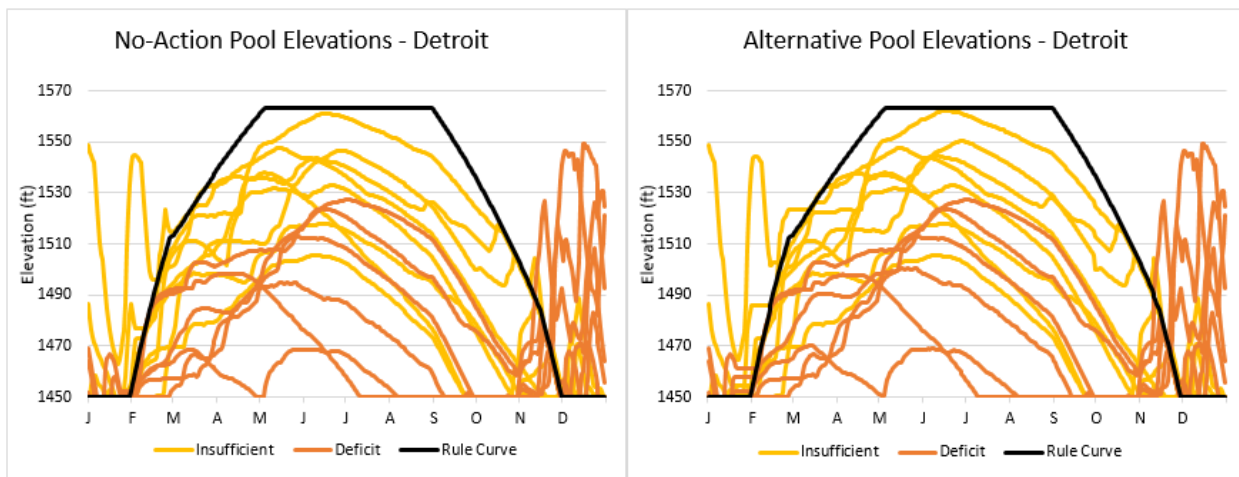

Figure 7-5. Detroit Dam and Reservoir No-action and Alternative Operations Pool Elevations in Insufficient and Deficit Water Years.

Dorena Dam and Reservoir:

Table 7-8. May Increase in Conservation Storage Associated with Alternative Operations at Dorena Dam and Reservoir.

Insufficient Year	1944	1965	1967	1968	1978	1987	1992	1994
KAF	4.3	0.0	Fill	0.0	0.0	0.0	8.8	3.6
Deficit Year	1941	1942	1973	1977	2001	2015		
KAF	0.1	Fill	4.1	Fill	0.0	2.5		

*Fill indicates that the reservoir filled under baseline conditions.

*Willamette Valley System Operations and Maintenance
Environmental Impact Statement*

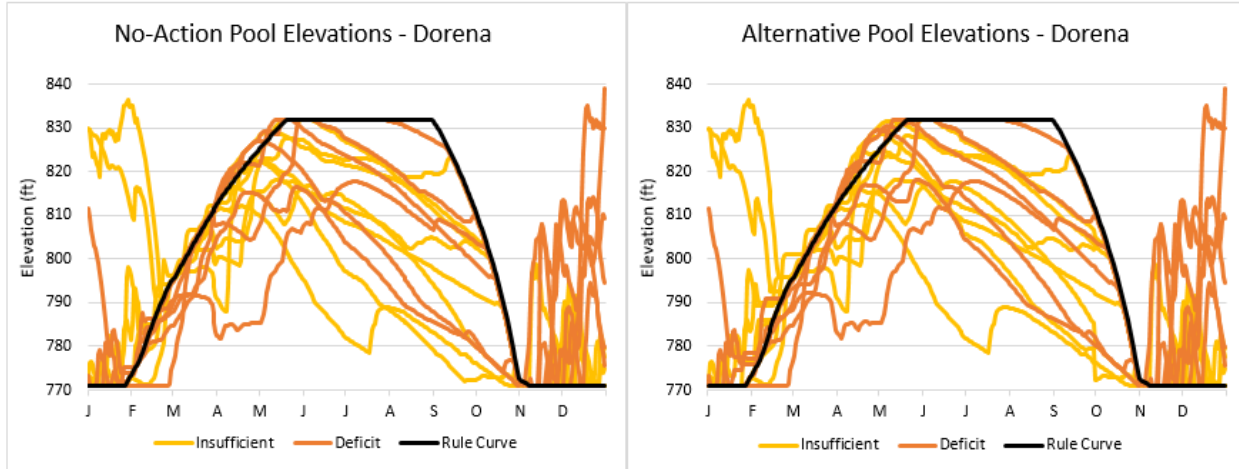

Figure 7-6. Dorena Dam and Reservoir No-action and Alternative Operations Pool Elevations in Insufficient and Deficit Water Years.

Fall Creek Dam and Reservoir:

Table 7-9. May Increase in Conservation Storage Associated with Alternative Operations at Fall Creek Dam and Reservoir.

Insufficient Year	1944	1965	1967	1968	1978	1987	1992	1994
KAF	Fill	3.2	Fill	1.9	8.5	1.0	0.9	1.6
Deficit Year	1941	1942	1973	1977	2001	2015		
KAF	6.4	Fill	2.9	Fill	1.1	0.9		

*Fill indicates that the reservoir filled under baseline conditions.

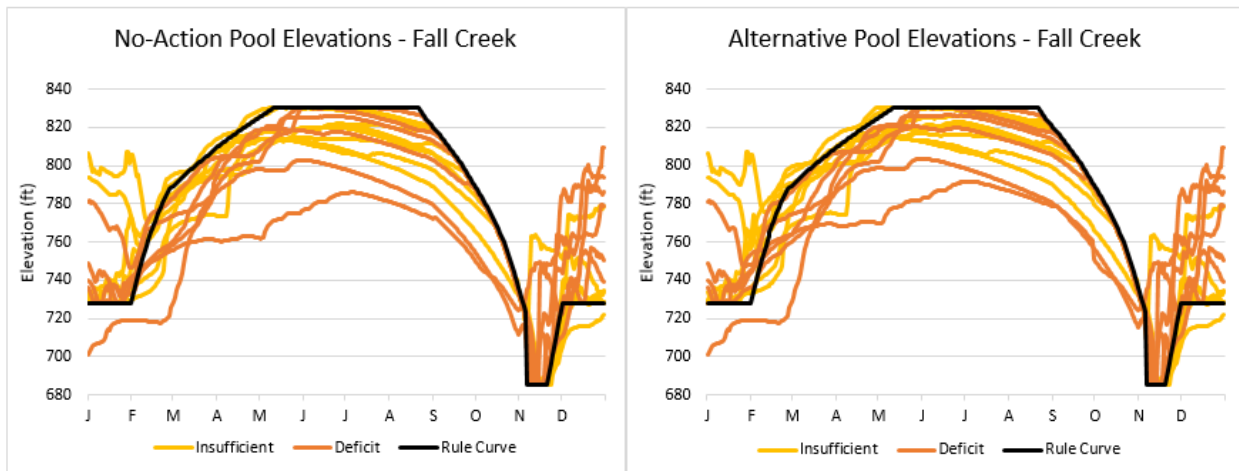

Figure 7-7. Fall Creek No-action and Alternative Operations Pool Elevations in Insufficient and Deficit Water Years.

*Willamette Valley System Operations and Maintenance
Environmental Impact Statement*

Fern Ridge Dam and Reservoir:

Table 7-10. April Increase in Conservation Storage Associated with Alternative Operations at Fern Ridge Dam and Reservoir.

Insufficient Year	1944	1965	1967	1968	1978	1987	1992	1994
KAF	0.0	11.5	Fill	0.0	0.0	0.0	0.0	0.0
Deficit Year	1941	1942	1973	1977	2001	2015		
KAF	0.0	0.0	0.0	0.0	0.0	0.0		

*Fill indicates that the reservoir filled under baseline conditions.

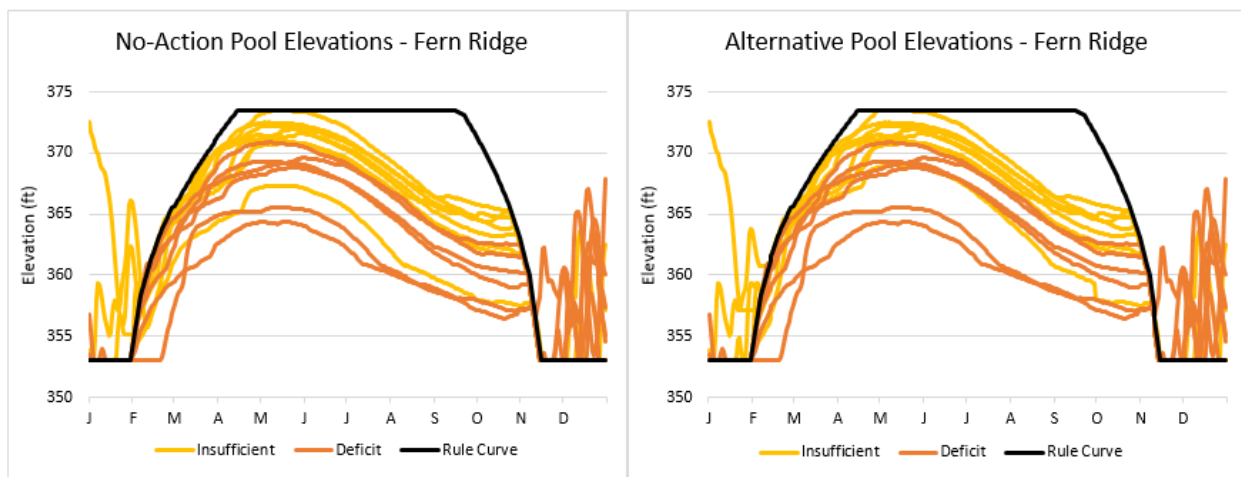

Figure 7-8. Fern Ridge Dam and Reservoir No-action and Alternative Operations Pool Elevations in Insufficient and Deficit Water Years.

Green Peter Dam and Reservoir:

Table 7-11. May Increase in Conservation Storage Associated with Alternative Operations at Green Peter Dam and Reservoir.

Insufficient Year	1944	1965	1967	1968	1978	1987	1992	1994
KAF	0.0	0.9	Fill	1.7	3.4	0.0	0.0	0.0
Deficit Year	1941	1942	1973	1977	2001	2015		
KAF	0.0	0.0	25.4	Fill	0.0	3.2		

*Fill indicates that the reservoir filled under baseline conditions.

*Willamette Valley System Operations and Maintenance
Environmental Impact Statement*

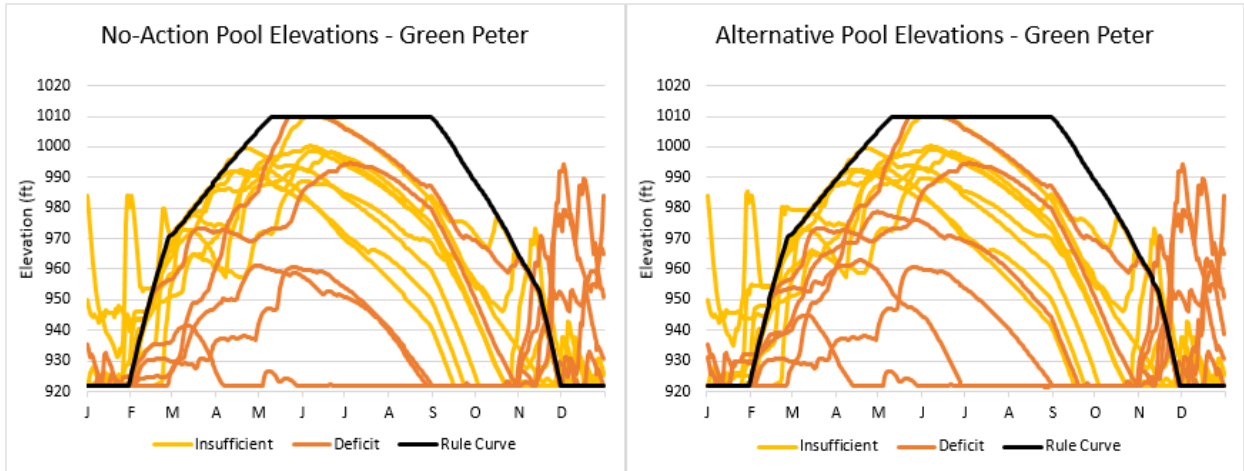

Figure 7-9. Green Peter Dam and Reservoir No-action and Alternative Operations Pool Elevations in Insufficient and Deficit Water Years.

Hills Creek Dam and Reservoir:

Table 7-12. May 15 Increase in Conservation Storage Associated with Alternative Operations at Hills Creek Dam and Reservoir.

Insufficient Year	1944	1965	1967	1968	1978	1987	1992	1994
KAF	0.0	0.0	0.0	0.0	0.0	0.0	0.0	0.0
Deficit Year	1941	1942	1973	1977	2001	2015		
KAF	0.0	0.0	0.0	0.0	0.0	0.0		

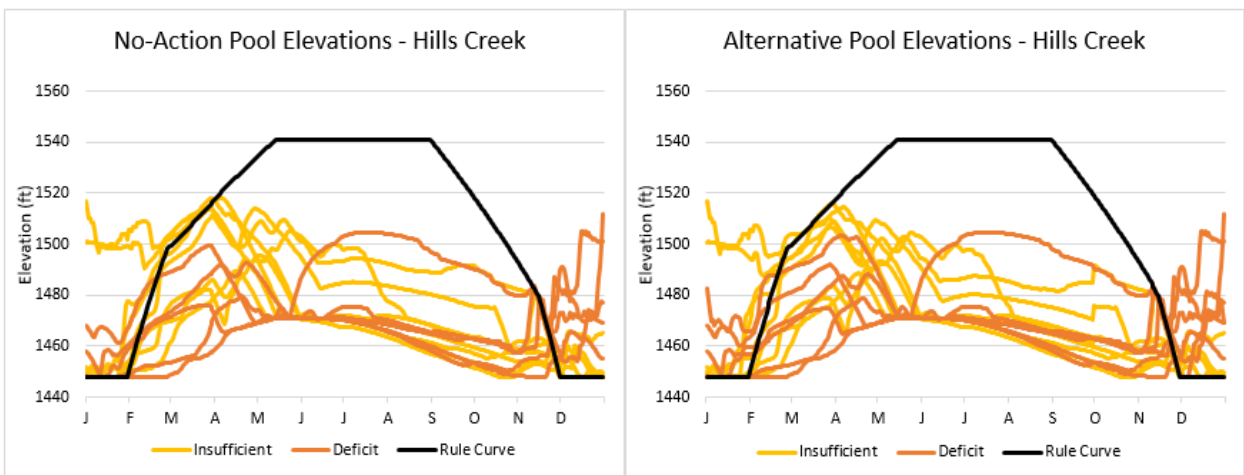

Figure 7-10. Hills Creek Dam and Reservoir No-action and Alternative Operations Pool Elevations in Insufficient and Deficit Water Years.

Lookout Point Dam and Reservoir:

Table 7-13. May Increase in Conservation Storage Associated with Alternative Operations at Lookout Point Dam and Reservoir.

Insufficient Year	1944	1965	1967	1968	1978	1987	1992	1994
KAF	0.6	Fill	Fill	0.0	14.4	0.0	0.0	0.0
Deficit Year	1941	1942	1973	1977	2001	2015		
KAF	0.0	0.0	0.0	6.9	0.0	0.0		

*Fill indicates that the reservoir filled under baseline conditions.

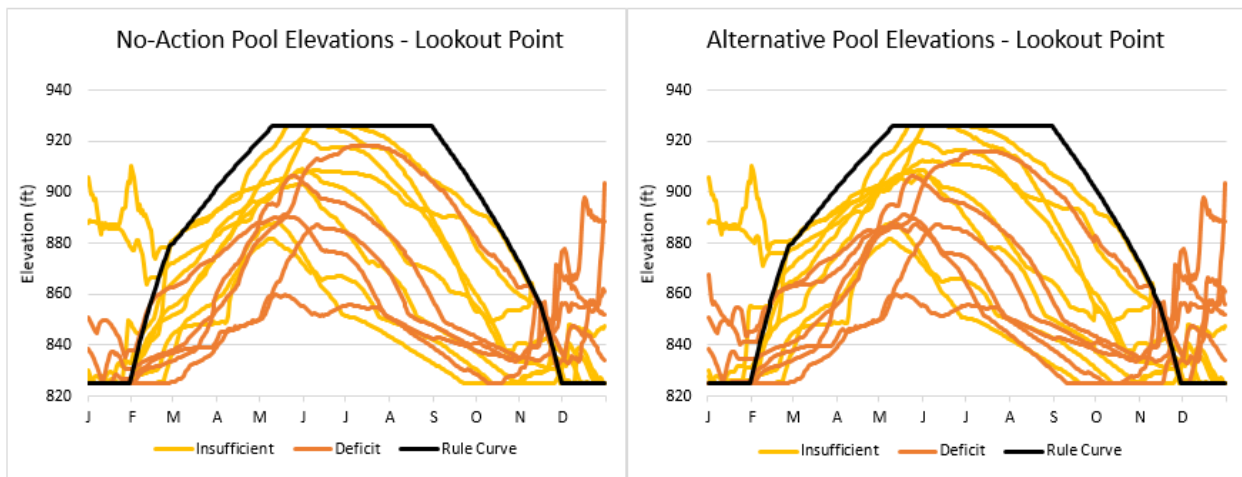

Figure 7-11. Lookout Point Dam and Reservoir No-action and Alternative Operations Pool Elevations in Insufficient and Deficit Water Years.

8 FLOOD RISK ASSOCIATED WITH HOLDING WILLAMETTE VALLEY RESERVOIRS WITH SECONDARY FLOOD STORAGE AT THE TOP OF THE SECONDARY FLOOD POOL DURING THE WINTER – 1964 AND 1996 CASE STUDY

Targeting the top of the secondary flood pool at Willamette Valley System (WVS) reservoirs in the winter instead of the minimum conservation elevation, with the goal of increasing the magnitude of spring refill, has been proposed as a measure for evaluation as part of the Willamette Valley System (WVS) Environmental Impact Statement (EIS) study. Six WVS reservoirs have secondary flood pools. Figure 8-1 identifies the secondary flood storage and total maximum conservation storage at each reservoir. This analysis aims to identify potential impacts to flood risk management (FRM) associated with the proposed alternative operation.

A reduction in winter flood storage is associated with an increase in flood risk. Reservoirs store water during high precipitation events to reduce flows downstream, resulting in higher pool

elevations. The higher the pool elevation, the smaller rain event required to raise the pool to elevations where uncontrolled releases are required.

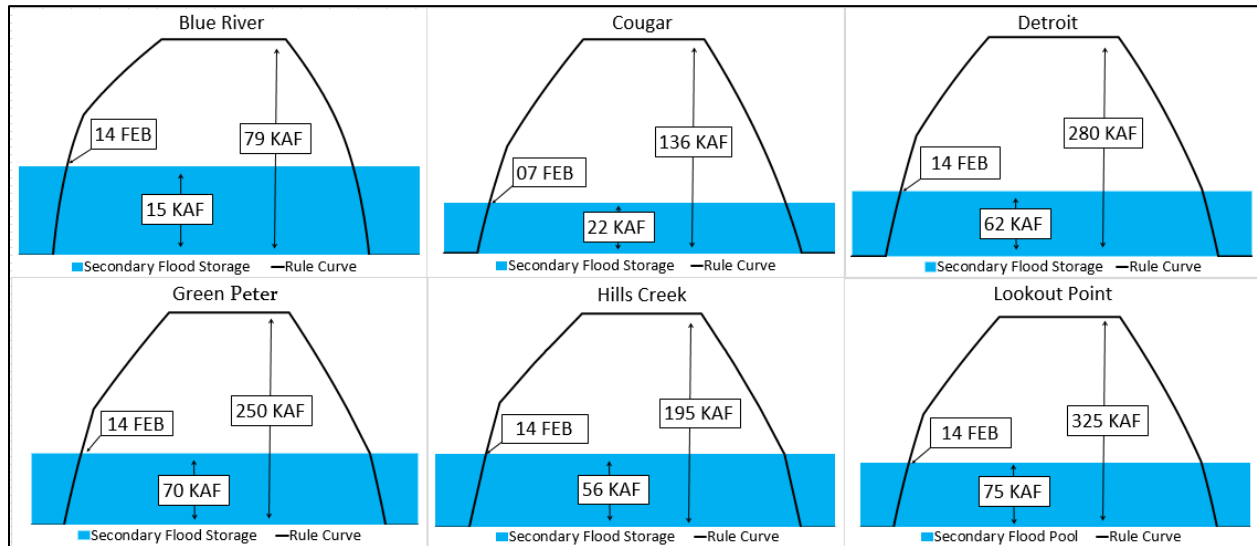

Figure 8-1. Secondary Flood Storage at Willamette Valley Reservoirs.

8.1 Methods

Increases in flood risk associated with targeting the top of the secondary flood pool at Cougar, Detroit, Green Peter, Lookout Point, Hills Creek, and Blue River Reservoirs during the winter are investigated using the HEC-ResSim model and Flood Insurance Study (FIS) watershed. The model applies reservoir operational rules under various hydrologic conditions to simulate regulated flow and reservoir elevations throughout the basin. The Willamette River Basin HEC-ResSim model includes all thirteen WVS reservoirs, along with the operational rules and constraints at each location, which are designed to achieve both project-specific and system-wide objectives as specified in the project and system Water Control Manuals. The FIS watershed uses a 3-hour simulation time step and hourly ramping rates to model flood operations.

The FIS watershed is best suited for single flood event modeling under baseline conditions. Small changes in reservoir operations can lead to model instability unless care is taken to choose the appropriate simulation start and end dates. This is due in large part to the short simulation time step of 3 hours, which makes the simulation more sensitive to small changes, but also helps capture peak flows and reservoir elevations. For this reason, only the 1964 and 1996 high water events are modeled as part of this analysis.

The 1964 event was a basin wide rain on snow event occurring in mid-December. The 1964 event was chosen as a case study because it is known to have impacted all subbasins with reservoirs with secondary flood pools and is well known to reservoir regulators.

The 1996 event was also a rain on snow event occurring in late January and early February. The 1996 event most heavily impacted the Santiam River Subbasin relative to other subbasins in the

*Willamette Valley System Operations and Maintenance
Environmental Impact Statement*

larger Willamette River Basin. The 1996 event was chosen as a case study because it occurred within recent memory, occurred under current levels of flood risk protection, and spanned the transition from winter flood operations to spring refill.

Evaluation of the impacts to flood risk management associated with targeting the top of the secondary flood pools at Cougar, Detroit, Green Peter, Lookout Point, Hills Creek, and Blue River Reservoirs during the winter is carried out by comparing plots showing reservoir elevations and control point regulation flows from the No-action baseline simulation and the secondary flood pool alternative simulation. Willamette River Basin control point regulation flows are provided in Table 8-1.

Table 8-1. Flood Regulation Goals at Willamette Valley System Dams and Reservoirs.

Station ID	Station Name	Action Stage/(Bankfull) ^{1,3}	Flood Stage ^{2,3}	Major Flood Stage ^{2,3}
GOSO	Coast Fork Willamette River near Goshen	11.7 ft (12,100 cfs)	13.0 ft (14,900 cfs)	18.0 ft (41,000 cfs)
JASO	Middle Fork Willamette at Jasper	9.4 ft (20,000 cfs)	10.0 ft (23,000 cfs)	15.0 ft (65,200 cfs)
EUGO	Willamette River at Eugene	20.2 ft (39,500 cfs)	23.0 ft (52,600 cfs)	29.0 ft (94,300 cfs)
VIDO ⁴	McKenzie River near Vida	8.0 ft (22,200 cfs)	11.0 ft (35,000 cfs)	14.0 ft (49,500 cfs)
HARO ⁴	Willamette River at Harrisburg	10.8 ft (39,700 cfs)	14.0 ft (66,500 cfs)	17.0 ft (100,700 cfs)
MNRO ⁴	Long Tom River at Monroe	8.5 ft (5,660 cfs)	9.0 ft (6,780 cfs)	12.0 ft (16,000 cfs)
ALBO	Willamette River at Albany	21.6 ft (67,300 cfs)	25.0 ft (84,000 cfs)	32.0 ft (152,600 cfs)
WTLO	S. Santiam River at Waterloo	10.2 ft (19,000 cfs)	12.0 ft (25,700 cfs)	16.0 ft (42,700 cfs)
MEHO ⁴	N. Santiam River at Mehama	8.9 ft (17,000 cfs)	11.0 ft (30,500 cfs)	13.5 ft (53,600 cfs)
JFFO	Santiam River at Jefferson	13.0 ft (43,000 cfs)	15.0 ft (55,900 cfs)	23.0 ft (213,000 cfs)
SLMO	Willamette River at Salem	21.2 ft (94,000 cfs)	28.0 ft (154,300 cfs)	32.0 ft (201,700 cfs)

¹Action Stage [formerly “bankfull”] is set by the National Weather Service. It is defined as an established gage height at a given location along a river or stream, above which a rise in water surface will cause the river or stream to overflow the lowest natural stream bank somewhere in the corresponding reach. Refer to the new rating tables to determine flows as the ratings change on a regular basis, thus affecting flow.

²Flood Stage is set by the National Weather Service. It is defined as an established gage height for a given location above which a rise in water surface level begins to create a hazard to lives, property, or commerce. The issuance of flood advisories or warnings is linked to flood stage.

³Flows associated with Action Stage, Flood Stage, and Major Flood Stage may change as rating tables are updated.

⁴Action stage and regulation goal differ. VIDO regulation goal is 14,500 cfs. Harrisburg regulation goal is 52,000 cfs. Mehama regulation goal is 17,000 cfs. Maximum evacuation rate from Fern Ridge Dam and Reservoir is 3,000 cfs.

8.2 Results and Discussion

The December 1964 flood in the Willamette River Basin is attributed to warm rain melting snow on frozen ground. Many of the WVS reservoirs were not operating at full flood storage potential when the flood occurred. Lookout Point Dam and Reservoir is a notable exception, which filled to full pool in an effort to regulate downstream flows according to historic elevation and discharge records. In reservoir simulations, where all reservoirs are regulating in accordance with current operations, all reservoirs reach full pool in the No-action baseline simulation, spill to prevent overtopping, and release flows that exceed regulation stages downstream. Consequently, reservoirs in the alternative simulation storing water in the secondary flood pool reach full pool sooner and spill for a longer duration releasing an additional volume approximately equal to their secondary flood pools. Consequently, downstream flooding is increased.

All control points in the Willamette River Basin exceeded regulation stages in the baseline and all control points below reservoirs with secondary flood pools exceeded regulation stages by greater magnitudes or for longer durations as a result of alternative operations. Most notably, Harrisburg exceeded major flood stage for days in the alternative instead of hours in the baseline (Figure 8-2) and flows at Waterloo exceeded major flood stage in the alternative while only exceeding flood stage in the baseline (Figure 8-3). Peak flows at Salem were no higher in the alternative, but the duration of peak flows above major flood stage was increased by several days (Figure 8-4). Plots comparing alternative operation and baseline reservoir elevations for all reservoirs with secondary flood pools and control point flows downstream of these reservoirs resulting from the 1964 high water event are provided in the appendices.

To provide additional context, the 1996 event was also modeled with alternative operations. The 1996 event was also a rain on snow event that impacted the Santiam River Basin more than any other subbasin in the larger Willamette River Basin. Green Peter Reservoir very nearly reaches full pool in the baseline simulation. Model results suggest targeting the top of the secondary flood pool at Green Peter Reservoir in 1996 would result in the reservoir reaching full resulting in releases raising flows at Waterloo to above flood stage and approaching major flood stage. Green Peter Reservoir pool elevations during the 1996 event are shown in Figure 8-6, and control point flows at Waterloo are shown in Figure 8-7.

The probability a large event will be basin-wide or impact a particular subbasin is beyond the scope of this study, which is intended only to use known large events in the period of record to demonstrate the flood risk implications of decreasing winter flood storage. These provide examples of flood inducing storms occurring in mid-winter (1964) and early refill season (1996) where increases in the magnitude and duration of flows above regulation stages are anticipated to occur as a result of targeting the secondary flood pool in the winter.

Willamette Valley System Operations and Maintenance
Environmental Impact Statement

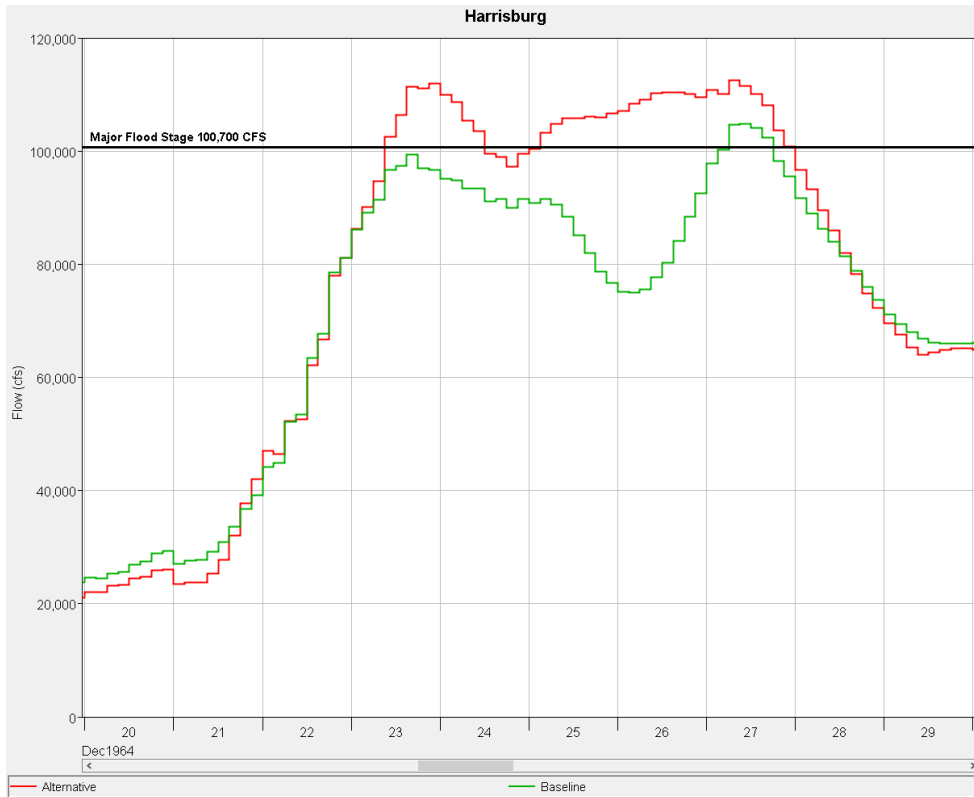

Figure 8-2. Willamette at Harrisburg, December 1964.

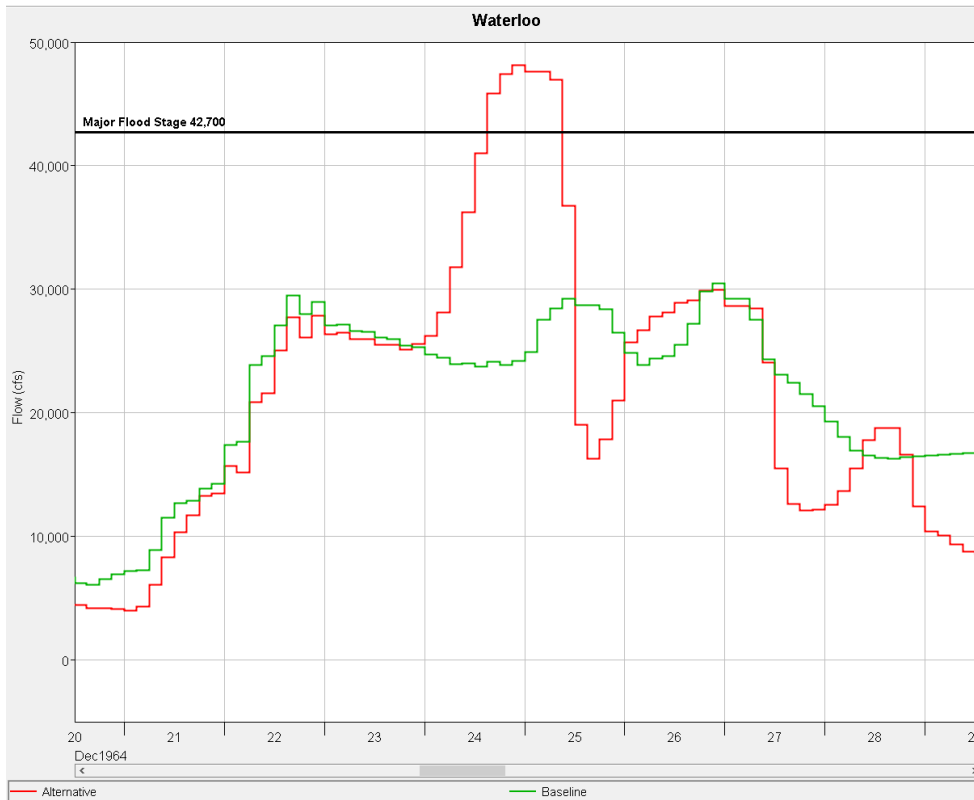

Figure 8-3. South Santiam at Waterloo December 1964.

*Willamette Valley System Operations and Maintenance
Environmental Impact Statement*

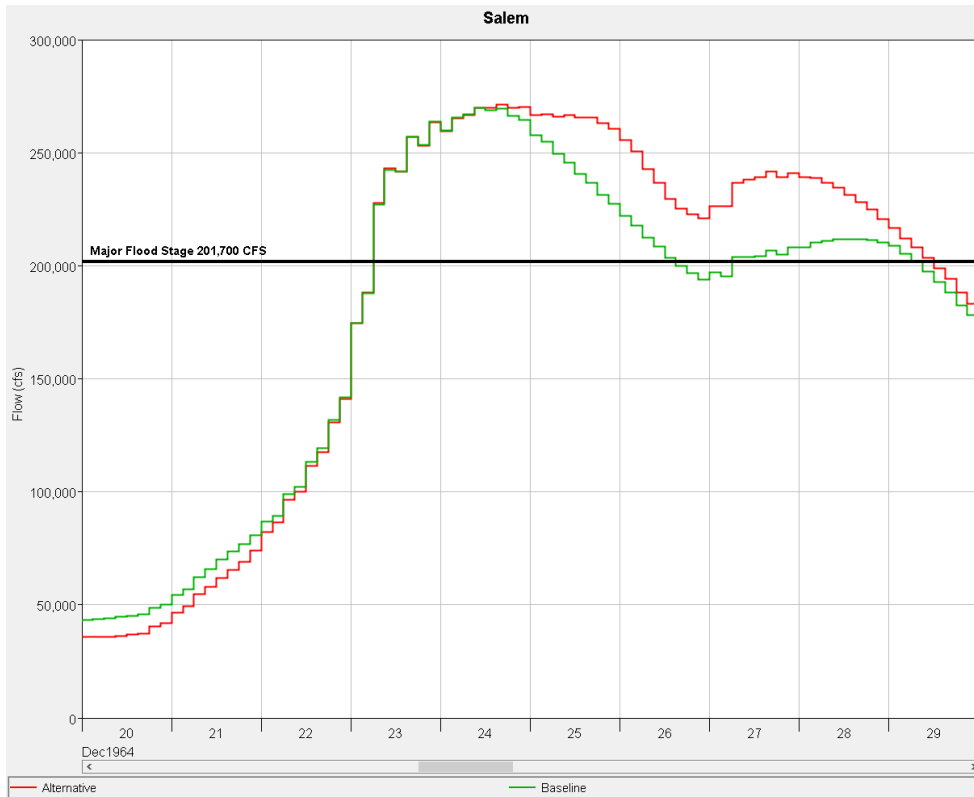

Figure 8-4. Willamette at Salem, December 1964.

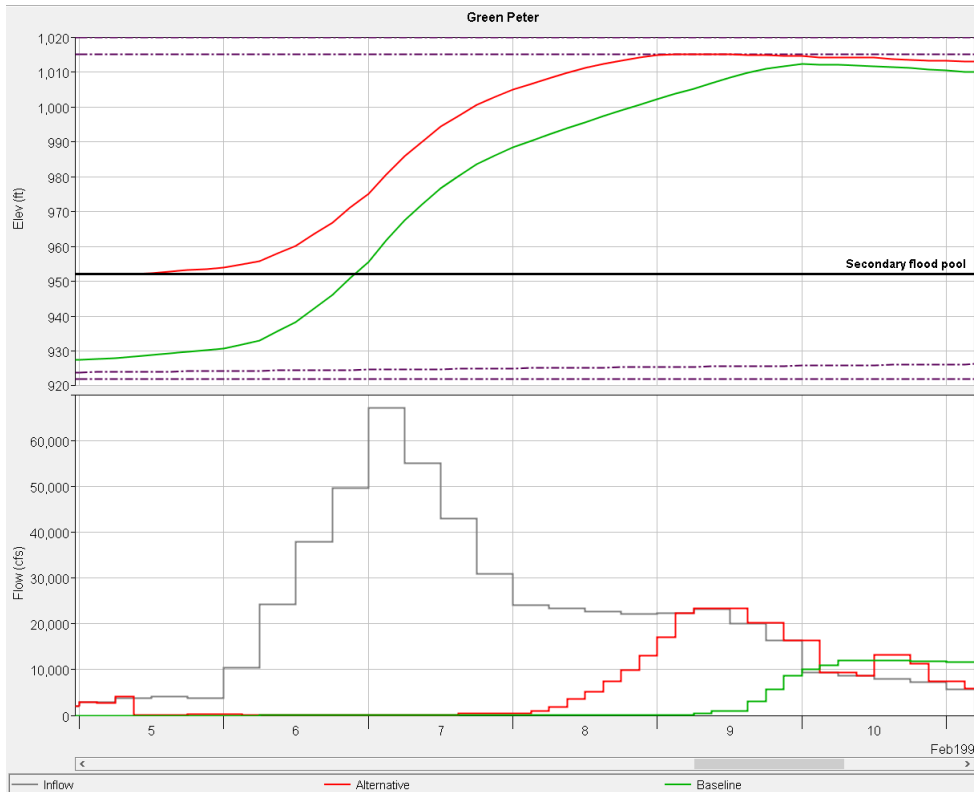

Figure 8-5. Green Peter Reservoir, February 1996.

*Willamette Valley System Operations and Maintenance
Environmental Impact Statement*

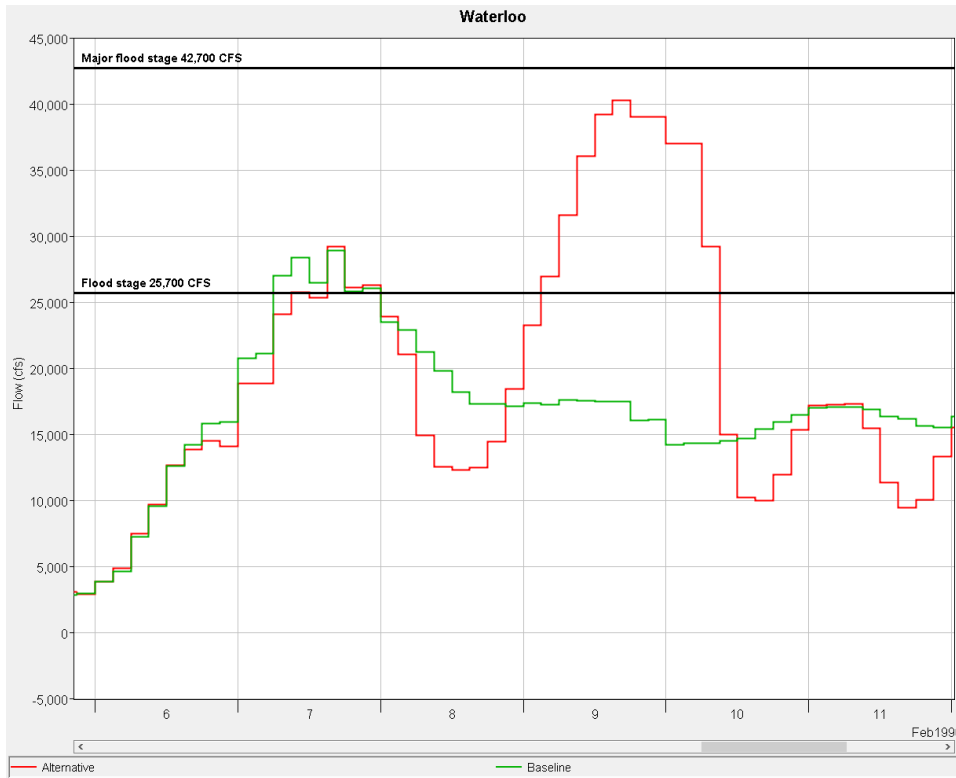

Figure 8-6. South Santiam at Waterloo, February 1996.

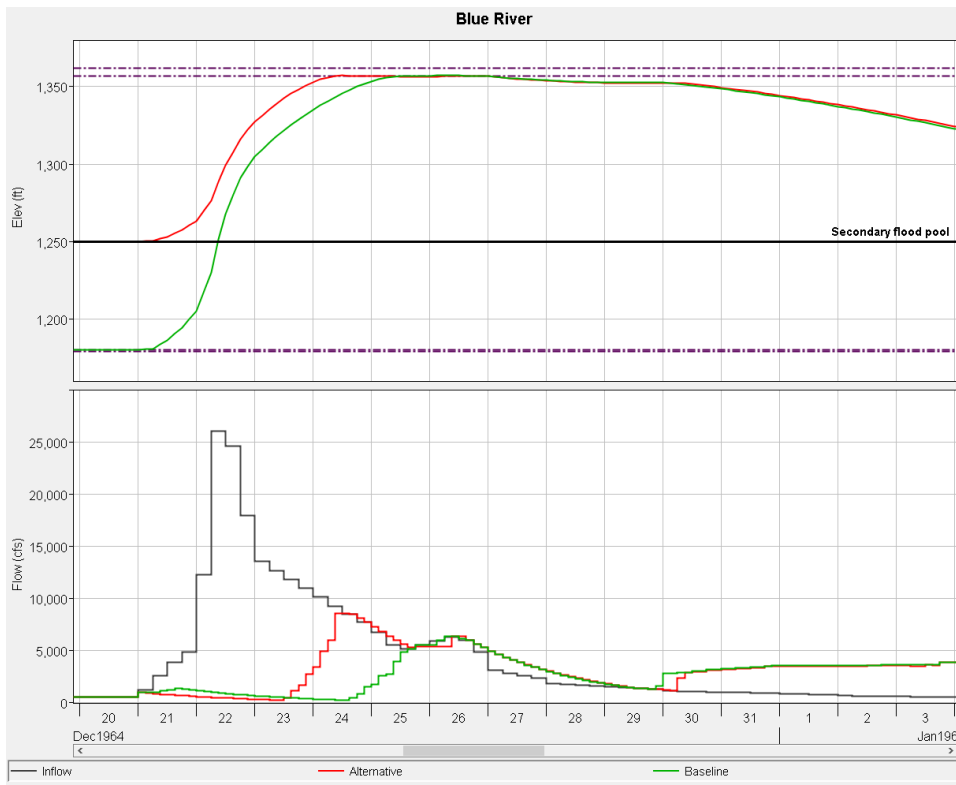

Figure 8-7. Blue River Dam and Reservoir, December 1964.

*Willamette Valley System Operations and Maintenance
Environmental Impact Statement*



Figure 8-8. Cougar Dam and Reservoir, December 1964.

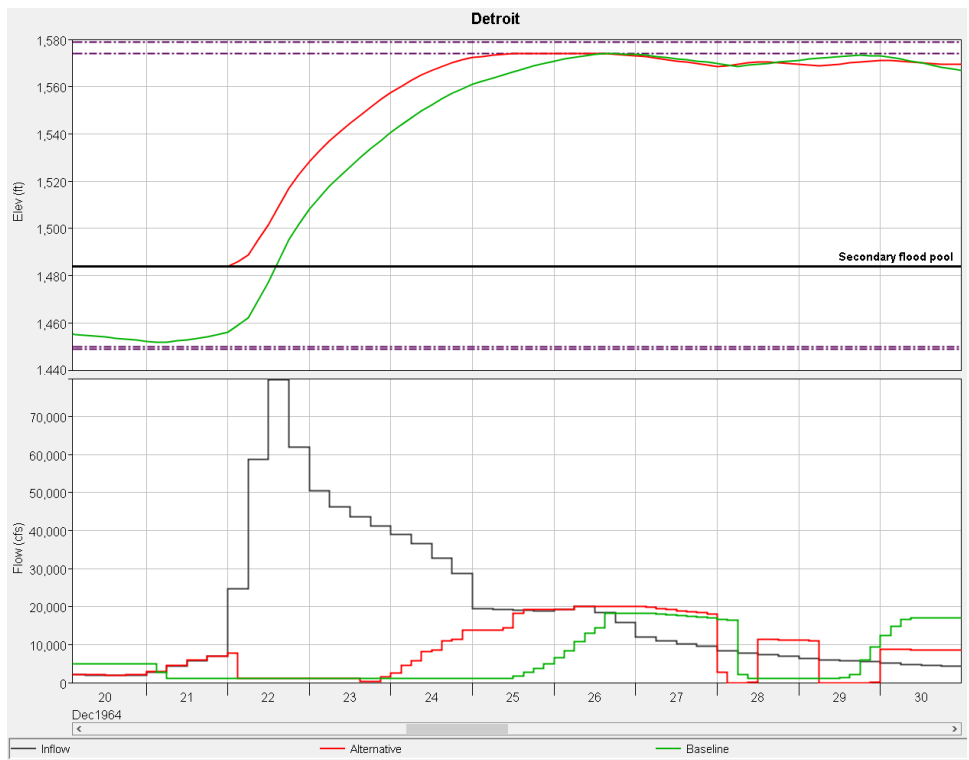

Figure 8-9. Detroit Dam and Reservoir, December 1964.

*Willamette Valley System Operations and Maintenance
Environmental Impact Statement*

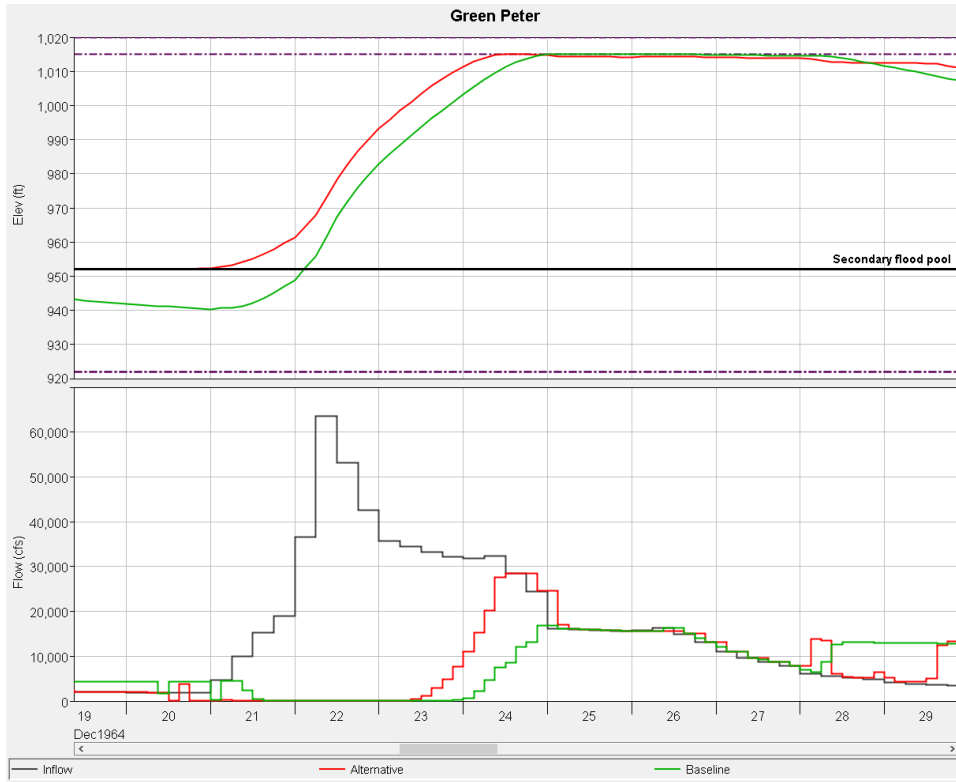

Figure 8-10. Green Peter Dam and Reservoir, December 1964.

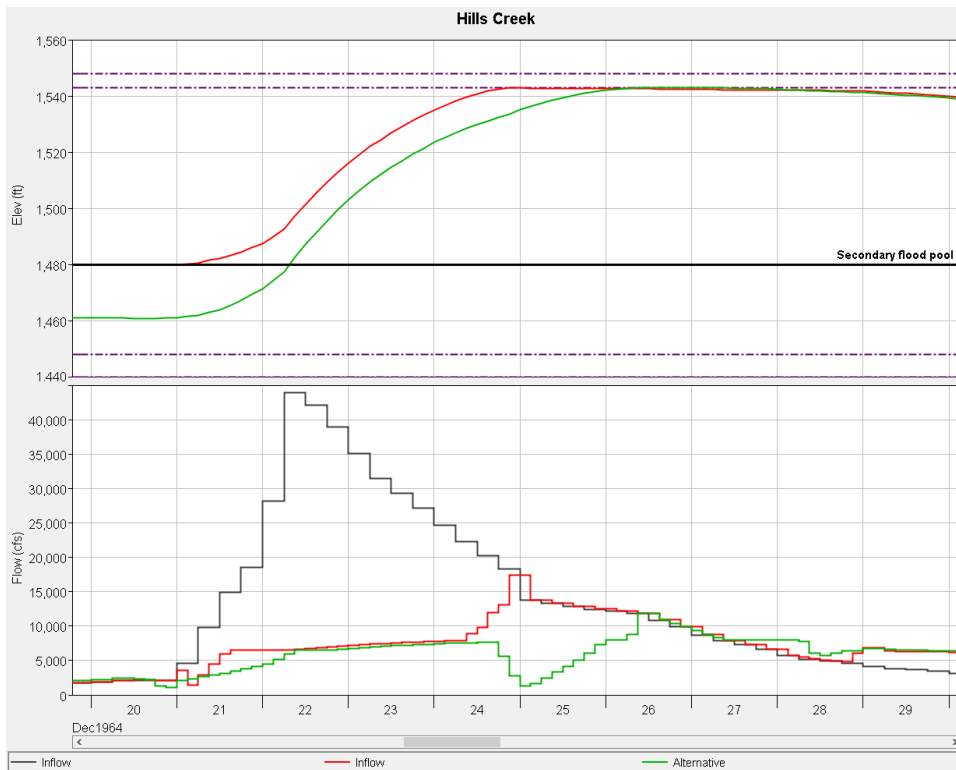

Figure 8-11. Hills Creek Dam and Reservoir, December 1964.

Willamette Valley System Operations and Maintenance
Environmental Impact Statement

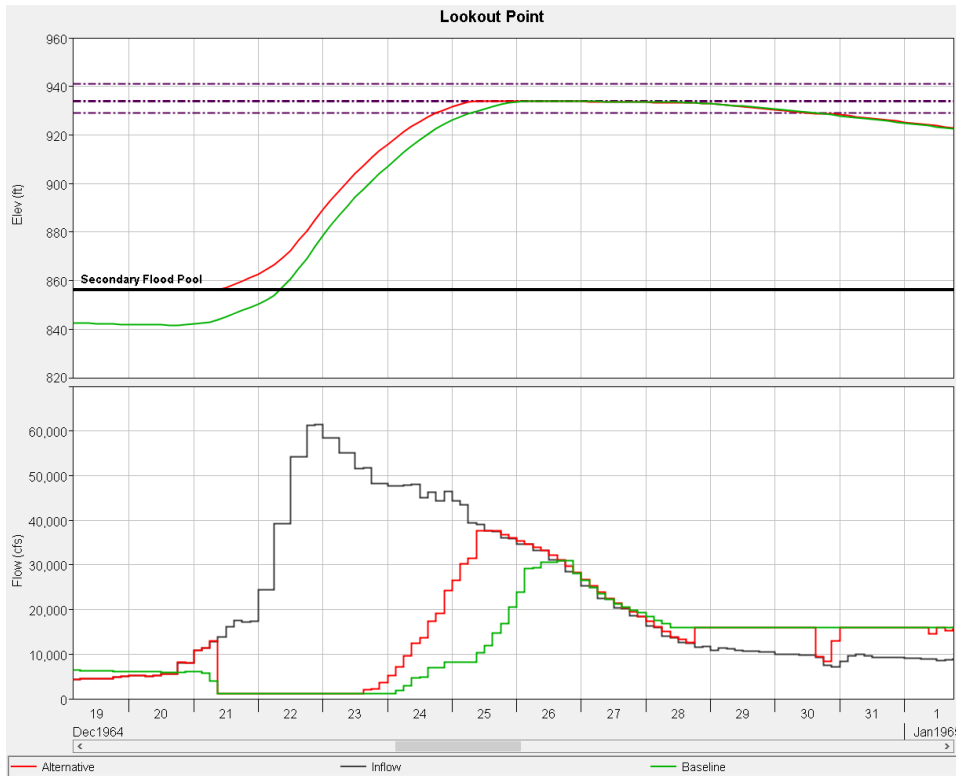

Figure 8-12. Lookout Point Dam and Reservoir, December 1964.

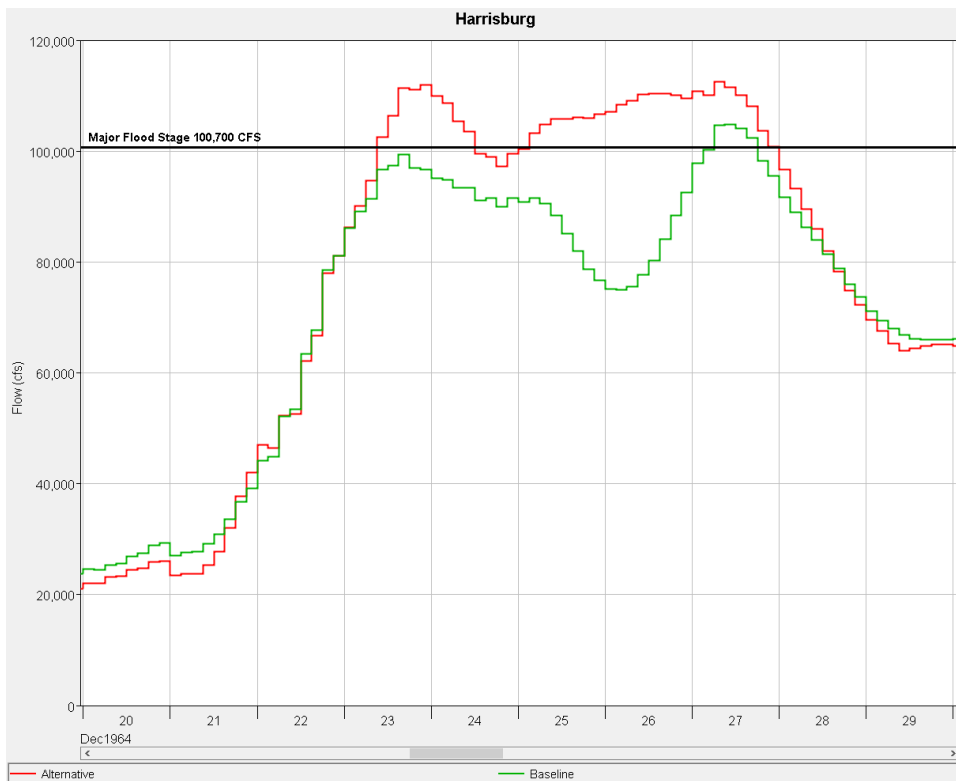

Figure 8-13. Harrisburg, December 1964.

Willamette Valley System Operations and Maintenance
Environmental Impact Statement

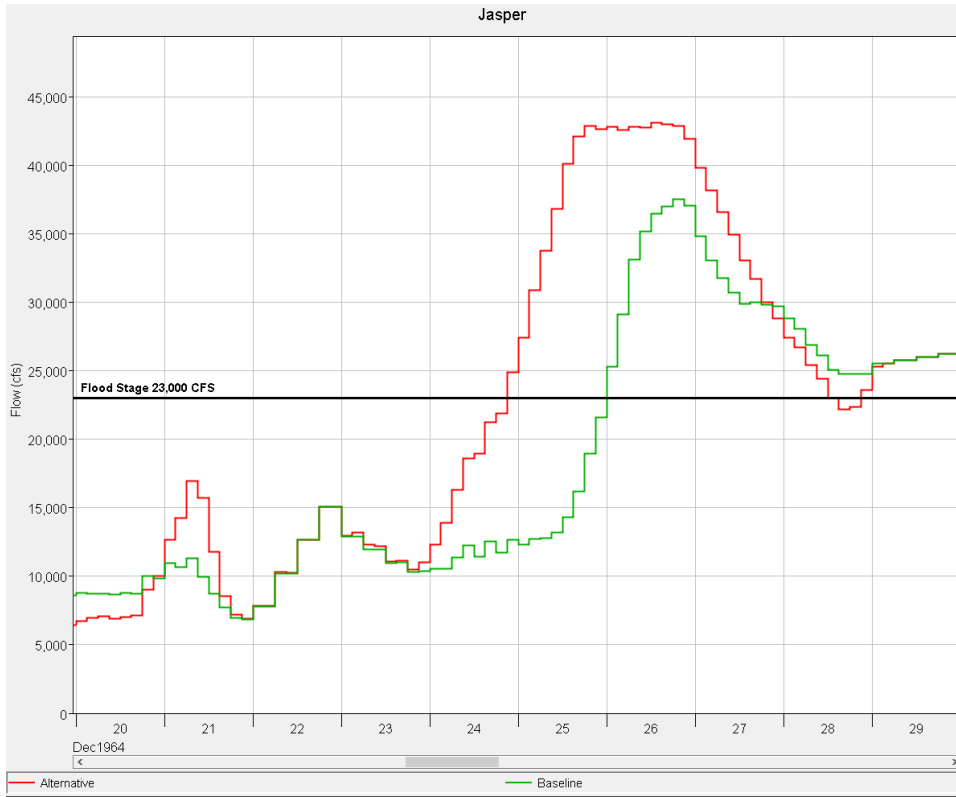

Figure 8-14. Jasper, December 1964.

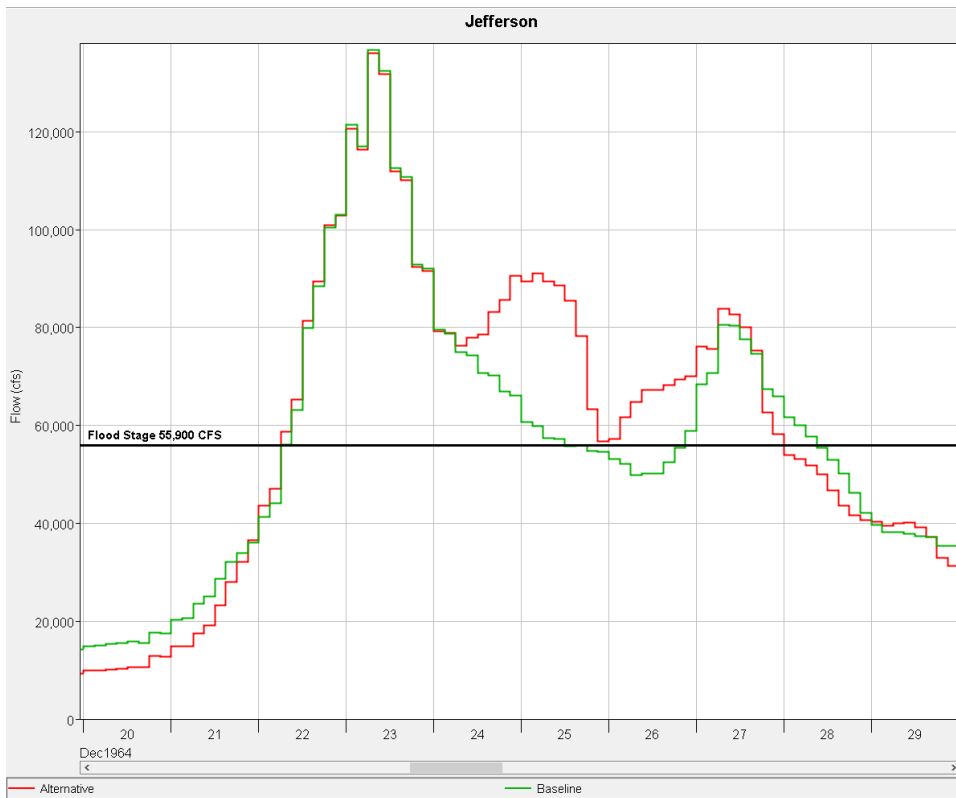

Figure 8-15. Jefferson, December 1964.

Willamette Valley System Operations and Maintenance
Environmental Impact Statement

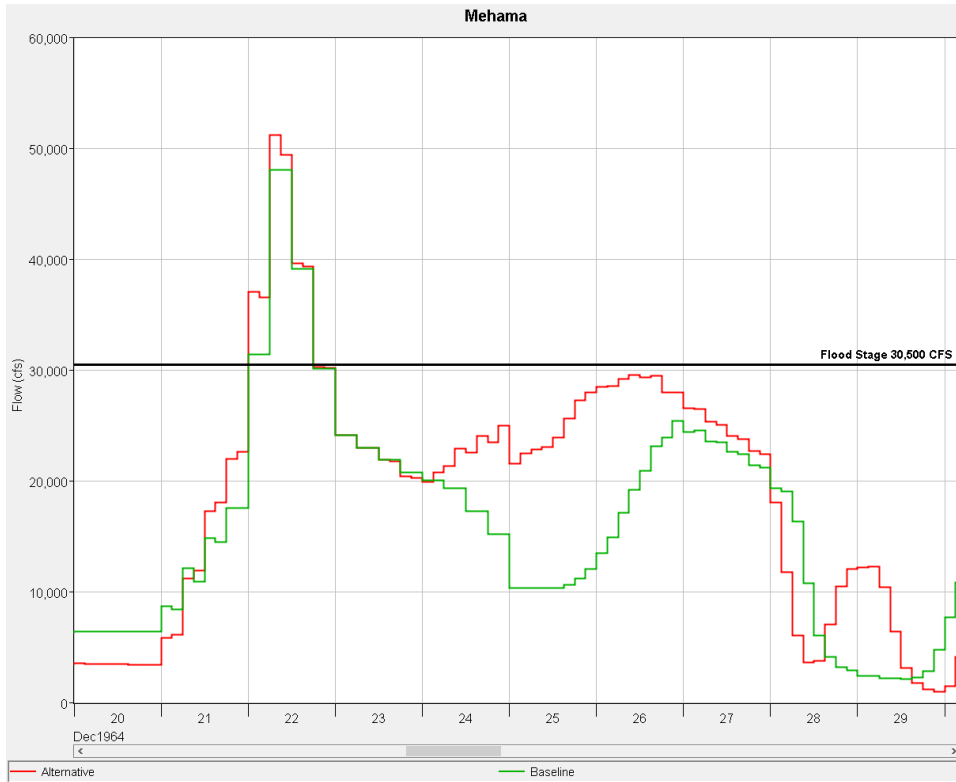

Figure 8-16. Mehama, December 1964.

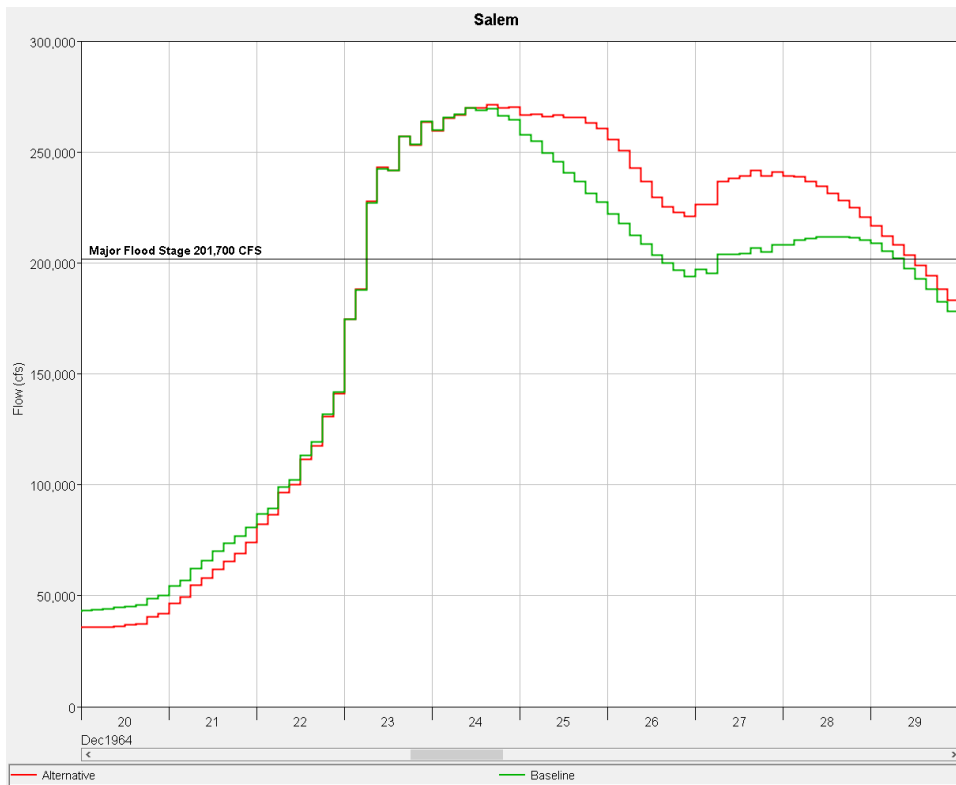

Figure 8-17. Salem, December 1964.

Willamette Valley System Operations and Maintenance
Environmental Impact Statement

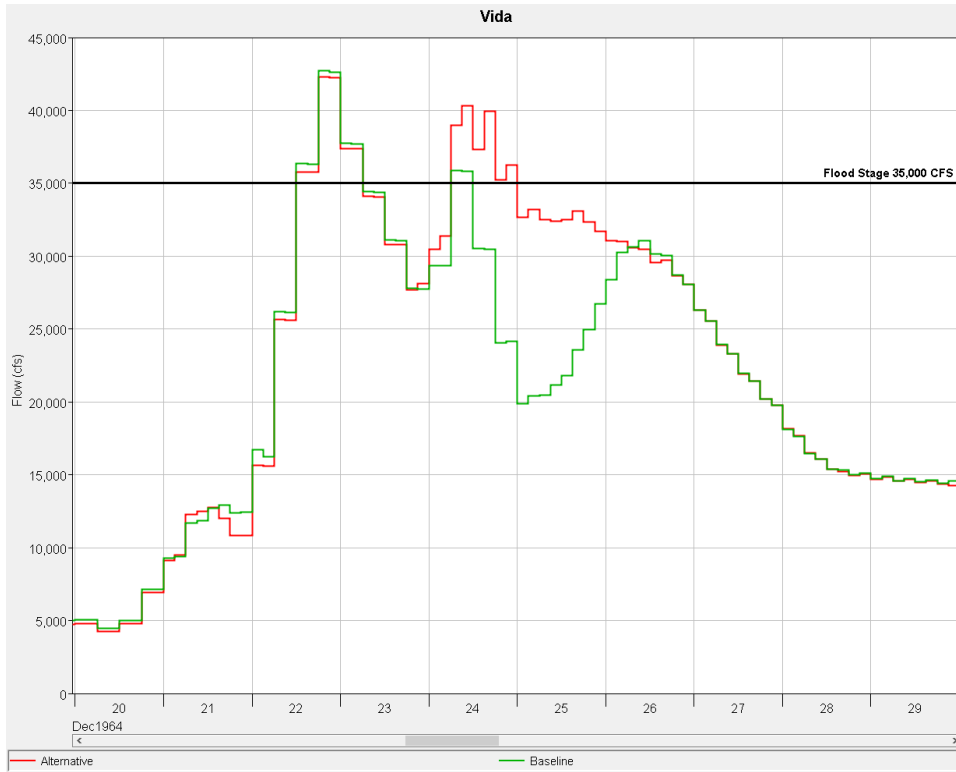

Figure 8-18. Vida, December 1964.

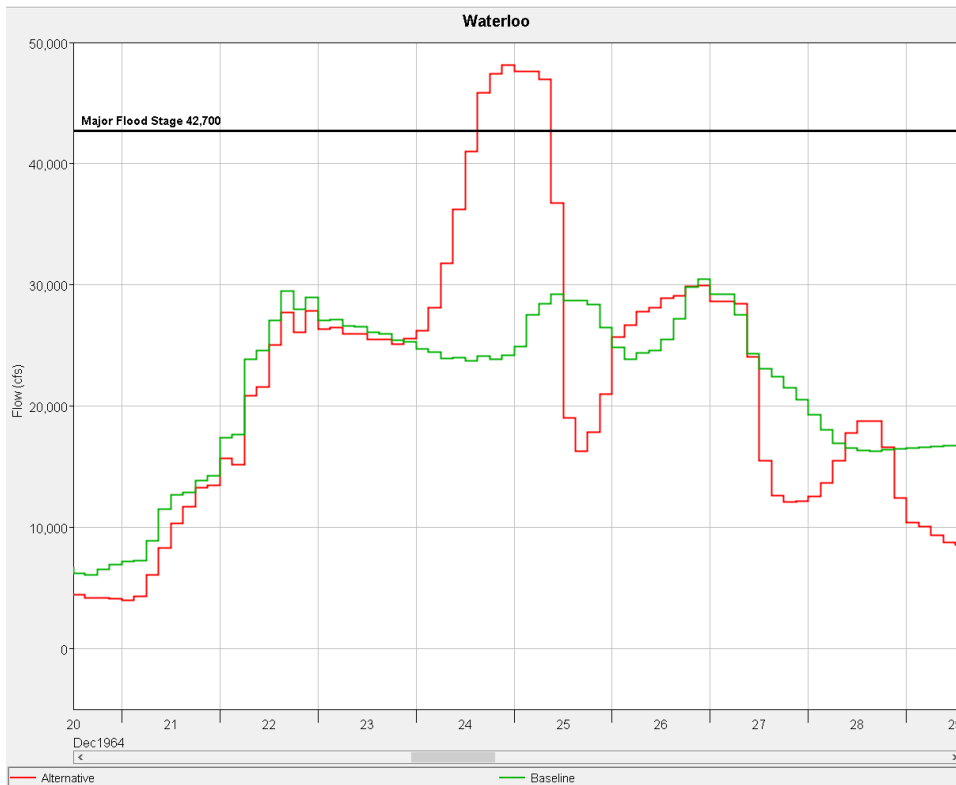

Figure 8-19. Waterloo, December 1964.

9 INCREASES IN CONSERVATION STORAGE ASSOCIATED WITH TARGETING THE TOP OF THE SECONDARY FLOOD POOL DURING THE WINTER AT WVS RESERVOIRS

Targeting the top of the secondary flood pool at Willamette Valley System (WVS) reservoirs in the winter instead of the minimum conservation elevation, with the goal of increasing the magnitude of spring refill, has been proposed as a measure for evaluation. This analysis identifies potential increases in conservation storage associated with the proposed alternative operation.

Six WVS reservoirs have secondary flood pools. Figure 9-1 identifies the secondary flood storage and total maximum conservation storage at each reservoir. The proposed alternative will likely guarantee spring refill to the top of the secondary flood pool by the date indicated in Figure 9-1. This will result in higher maximum conservation season storage in years when reservoirs do not fill to the guide curve after the dates indicated in Figure 9-1 under current operations.

A reduction in winter flood storage is associated with an increase in flood risk. Reservoirs store water during high precipitation events to reduce flows downstream, resulting in higher pool elevations. The higher the pool elevation, the smaller rain event required to raise the pool to elevations where uncontrolled releases are required. An analysis of impacts to flood risk management (FRM) will be required if benefits to conservation storage encourage further consideration of this measure.

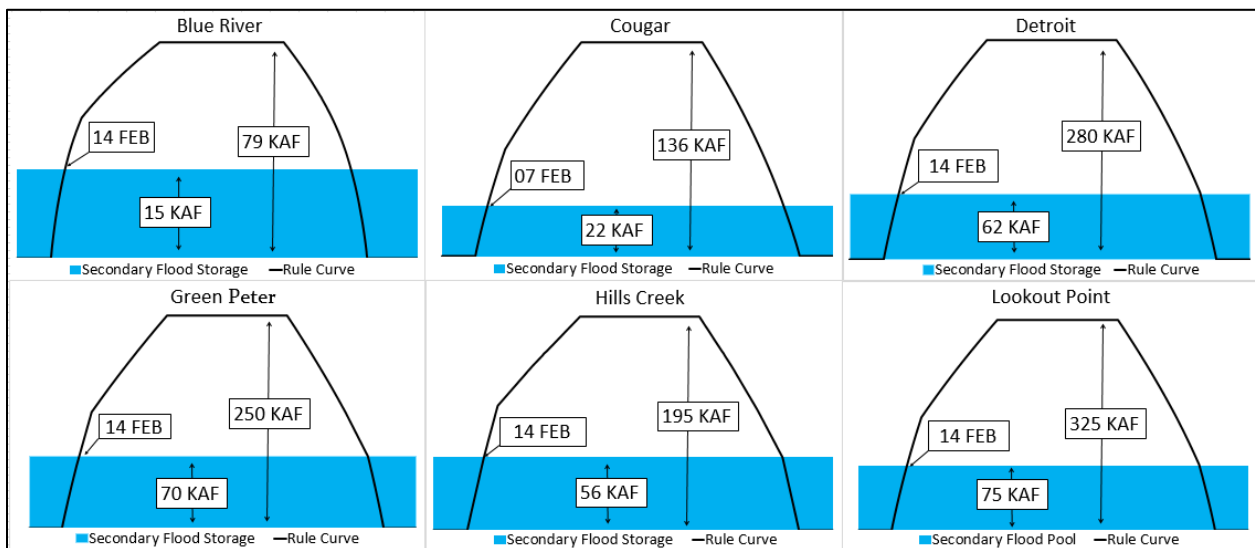

Figure 9-1. Secondary Flood Storage at Willamette Valley Reservoirs.

9.1 Methods

Increases on conservation storage associated with targeting the top of the secondary flood pool at Cougar, Detroit, Green Peter, Lookout Point, Hills Creek, and Blue River Reservoirs during the

*Willamette Valley System Operations and Maintenance
Environmental Impact Statement*

winter are investigated using the HEC-ResSim model. The model applies reservoir operational rules under various hydrologic conditions to simulate regulated in stream flow and reservoir elevations throughout the basin. The Willamette River Basin HEC-ResSim model includes all thirteen WVS reservoirs along with the operational rules and constraints at each location, which are designed to achieve both project-specific and system-wide objectives as specified in the project and system Water Control Manuals.

Operational conditions and requirements are simulated using historical hydrology over a period of 84 years (1935–2019) on a daily time step. Increases in conservation storage associated with alternative operations will be evaluated by comparing the storage volume observed on 01 April resulting from the alternative simulation compared to the No-action Alternative (NAA) simulation in years when the reservoir does not reach the rule curve above the secondary flood pool in the NAA.

WVS EIS target minimum flows below WVS reservoirs in the baseline NAA are defined to meet 2008 NMFS Biological Opinion (NMFS 2008) flow targets and forecasted 2050 withdrawals previously defined by the Willamette Basin Review (USACE 2019). Alternate minimum flow regimes may be considered in WVS EIS alternatives. Early conservation season storage assessed on 01 April provides a meaningful snapshot of storage available to supplement conservation season minimum flows while not being impacted by future minimum flow requirements that may change in WVS EIS alternatives and specifically measures impacts to system storage before minimum flow requirements at Salem come into effect. Prioritization of the quantity of water drafted from individual reservoirs to supplement flows at Salem and Albany are determined by logic attempting to maintain distributed system storage in HEC-ResSim and will not be consistent between the baseline and alternative simulations.

If elevations reach the rule curve after exceeding the secondary flood pool elevation in the NAA, then no benefit from the alternative operation is anticipated. Therefore, differences in reservoir storage between the NAA and alternative on 01 April were assigned a value of zero if the NAA reaches the rule curve after having exceeded the secondary flood pool elevation. The maximum increase in storage that can be attributed to the alternative operation is the storage capacity of the secondary flood pool. If model results show larger increases due to unforeseen discrepancies between the two model runs, those values were edited to indicate a storage increase equal to the storage capacity of the secondary flood pool.

In some years storage increases in the alternative may be limited by the rule curve but not in the NAA. If this occurs after 01 April, then 01 April storage differences may overestimate the benefit of the alternative operation. However, a different flow regime in a future WVS EIS alternative may prevent this from occurring and so values will not be edited when this occurs. When this scenario is identified its occurrence will be indicated in the results.

WVS EIS baseline minimum flows by water year type are presented in Table 9-1 through Table 9-8. Minimum flows shown are a composite of 2008 NMFS Biological Opinion (NMFS 2008) flow targets and releases required to meet forecasted 2070 Willamette Basin Review (USACE 2019) withdrawals. Minimum flows between 01 January and 01 April affect system storage on 01

*Willamette Valley System Operations and Maintenance
Environmental Impact Statement*

April. Table 9-9 indicates the flow in cubic feet per second (cfs) that can be sustained over 30 days by releasing stored volume in increments of kilo acre-feet (kaf) to help make the connection between stored water and potential releases.

Table 9-1. Minimum Flows Required to Meet BiOp and Projected 2070 Withdrawals at Detroit Dam and Reservoir.

WY	Jan	Feb	1-Mar	16-Mar	Apr	May	Jun	1-Jul	15-Jul	Aug	Sep	1-Oct	16-Oct	Nov	Dec
Deficit	1200	1000	1000	1500	1501	1512	1231	1258	1058	1054	1525	1501	1201	1200	1200
Insufficient	1200	1000	1000	1500	1501	1531	1274	1331	1131	1116	1555	1501	1201	1200	1200
Moderate	1200	1000	1000	1500	1501	1535	1285	1351	1151	1135	1564	1501	1201	1200	1200
Abundant	1200	1000	1000	1500	1501	1539	1294	1368	1168	1151	1571	1501	1201	1200	1200

Table 9-2. Minimum Flows Required to Meet BiOp and Projected 2070 Withdrawals at Green Peter/Foster Dams and Reservoirs¹.

WY	Jan	Feb	1-Mar	16-Mar	Apr	May	Jun	1-Jul	15-Jul	Aug	Sep	1-Oct	16-Oct	Nov	Dec
Deficit	1100	800	800	1500	1500	1504	1104	1110	818	817	1508	1500	1100	1100	1100
Insufficient	1100	800	800	1500	1500	1505	1105	1114	827	825	1511	1500	1100	1100	1100
Moderate	1100	800	800	1500	1500	1507	1107	1118	833	831	1514	1500	1100	1100	1100
Abundant	1100	800	800	1500	1500	1508	1108	1121	839	836	1517	1500	1100	1100	1100

¹Minimum flows out of Green Peter Dam and Reservoir are modeled to meet minimum flows below Foster Dam and Reservoir while accounting contribution from S. Santiam.

Table 9-3. Minimum Flows Required to Meet Biological Opinion and Projected 2070 Withdrawals at Blue River Dam and Reservoir.

WY	Jan	Feb	Mar	Apr	May	Jun	Jul	Aug	Sep	Oct	Nov	Dec
Deficit	50	50	50	50	52	56	61	61	55	50	50	50
Insufficient	50	50	50	50	53	59	66	65	57	50	50	50
Moderate	50	50	50	50	54	61	70	69	59	50	50	50
Abundant	50	50	50	50	55	63	73	72	60	50	50	50

Table 9-4. Minimum Flows Required to Meet Biological Opinion and Projected 2070 Withdrawals at Cougar Dam and Reservoir².

WY	Jan	Feb	Mar	Apr	May	Jun	Jul	Aug	Sep	Oct	Nov	Dec
Deficit	400	400	400	400	400	410	400	400	400	400	400	400
Insufficient	400	400	400	400	400	415	400	400	400	400	400	400
Moderate	400	400	400	400	400	419	400	400	400	400	400	400
Abundant	400	400	400	400	400	422	400	400	400	400	400	400

²Minimum NMFS 2008 BiOp flow out of Cougar Dam and Reservoir is 300 cfs except in June, but minimum fish facility flows are 400 cfs year-round, which also meets required demand for withdrawals July through May.

*Willamette Valley System Operations and Maintenance
Environmental Impact Statement*

Table 9-5. Minimum Flows Required to Meet BiOp and Projected 2070 Withdrawals at Hills Creek Dam and Reservoir.

WY	Jan	Feb	Mar	Apr	May	Jun	Jul	Aug	Sep	Oct	Nov	Dec
Deficit	400	400	400	400	405	412	423	422	410	400	400	400
Insufficient	400	400	400	400	407	418	433	431	414	400	400	400
Moderate	400	400	400	400	408	422	441	439	418	400	400	400
Abundant	400	400	400	400	410	426	448	445	421	400	400	400

Table 9-6. Minimum Flows Required to Meet BiOp and Projected 2070 Withdrawals at Lookout Point Dam and Reservoir.

WY	Jan	Feb	Mar	Apr	May	Jun	Jul	Aug	Sep	Oct	Nov	Dec
Deficit	1200	1200	1200	1201	1212	1233	1261	1257	1226	1201	1200	1200
Insufficient	1200	1200	1200	1201	1218	1247	1288	1282	1238	1201	1200	1200
Moderate	1200	1200	1200	1201	1222	1259	1310	1303	1247	1201	1200	1200
Abundant	1200	1200	1200	1201	1226	1269	1328	1320	1255	1201	1200	1200

Table 9-7. Minimum Flows Required to Meet BiOp and Projected 2070 Withdrawals at Albany³.

WY	Jan	Apr	16-Apr	1-May	1-Jun	16-Jun	1-Jul	1-Aug	16-Aug	1-Sep	1-Oct	1-Nov
Deficit	0	0	0	0	4000	4000	4000	4000	4000	4000	4000	0
Insufficient	0	0	0	0	4000	4000	4000	4000	4000	4000	4000	0
Moderate	0	0	0	0	4500	4500	4500	4500	4500	4500	4500	0
Abundant	0	0	0	0	4500	4500	4500	5000	5000	5000	5000	0

³Deficit and Insufficient targets at Albany are not defined in the NMFS 2008 BiOp, but instead reflect historical management practices.

Table 9-8. Minimum Flows Required to Meet BiOp and Projected 2070 Withdrawals at Salem.

WY	Jan	Apr	16-Apr	1-May	1-Jun	16-Jun	1-Jul	1-Aug	16-Aug	1-Sep	1-Oct	1-Nov
Deficit	0	15000	15000	15000	11000	5500	5000	5000	5000	5000	5000	0
Insufficient	0	15000	15000	15000	11000	5500	5000	5000	5000	5000	5000	0
Moderate	0	17800	17800	15000	13000	8700	6000	6000	6500	7000	7000	0
Abundant	0	17800	17800	15000	13000	8700	6000	6000	6500	7000	7000	0

Table 9-9. 1,000 Acre-Feet (kaf) Converted to cfs Sustainable over 30 days.

1,000 Acre-Ft	cfs sustained for 30 Days
1	17
2	34
3	50
4	67
5	84
6	101
7	117

*Willamette Valley System Operations and Maintenance
Environmental Impact Statement*

1,000 Acre-Ft	cfs sustained for 30 Days
8	134
9	151
10	168
11	184
12	201
13	218
14	235
15	252
16	268
17	285
18	302
19	319
20	335
21	352
22	369
23	386
24	402
25	419
26	436
27	453
28	470
29	486
30	503
31	520
32	537
33	553
34	570
35	587
36	604
37	620
38	637
39	654
40	671
41	688
42	704
43	721
44	738
45	755
46	782
47	799
48	816

*Willamette Valley System Operations and Maintenance
Environmental Impact Statement*

1,000 Acre-Ft	cfs sustained for 30 Days
49	833
50	850
51	867
52	884
53	901
54	918
55	935
56	952
57	969
58	986
59	1,003
60	1,020
61	1,023
62	1,040
63	1,057
64	1,073
65	1,090
66	1,107
67	1,124
68	1,140
69	1,157
70	1,174
71	1,191
72	1,207
73	1,224
74	1,241
75	1,258

9.2 Results

Blue River Dam and Reservoir:

Table 9-10 indicates the estimated increase in maximum conservation storage resulting from guaranteeing refill to the top of the secondary flood pool during spring refill at Blue River Dam and Reservoir. The secondary flood pool volume at Blue River Dam and Reservoir is 15 kaf, which is approximately 20 percent of the total 75 kaf of conservation storage capacity.

Blue River Reservoir fills nearly all Abundant water years in the baseline and therefore cannot realize a benefit from the alternative operations. Blue River Reservoir rarely fills in adequate water years, but the reservoir does fill to the rule curve after exceeding the secondary flood pool elevation in the baseline, and so no benefit from the alternative operation is realized. Increases in storage are observed in 38 percent (3 of 8) Insufficient water years with an average

*Willamette Valley System Operations and Maintenance
Environmental Impact Statement*

increase of 1.1 kaf, which is equivalent to 18 cfs released over 30 days. Increases are realized in 67 percent (4 of 6) deficit water years with a median increase of 6.4 kaf, which is equivalent to 107 cfs released over 30 days.

Benefits in 2005 decrease significantly later in the season as a result of Blue River Dam and Reservoir drafting to stay below the rule curve in the alternative while pool elevations rise in the baseline.

Table 9-10. April Increase in Conservation Storage Associated with Alternative Operations at Blue River Dam and Reservoir (“Fill” means that the reservoir fills under the baseline).

Abundant Year	KAF
1936	Fill
1937	Fill
1938	Fill
1943	Fill
1945	Fill
1948	Fill
1949	Fill
1950	Fill
1951	Fill
1952	Fill
1953	Fill
1955	Fill
1956	Fill
1957	0
1958	0
1960	Fill
1961	Fill
1962	Fill
1963	Fill
1969	Fill
1971	Fill
1972	Fill
1974	Fill
1975	Fill
1976	Fill
1979	Fill
1982	Fill
1983	0
1984	Fill
1988	Fill

*Willamette Valley System Operations and Maintenance
Environmental Impact Statement*

Abundant Year	KAF
1989	0
1991	Fill
1993	Fill
1995	Fill
1996	Fill
1997	Fill
1999	Fill
2000	0
2003	Fill
2008	Fill
2009	Fill
2011	Fill
2012	Fill
2014	Fill
2017	Fill
Adequate Year	KAF
1939	0
1940	0
1946	0
1947	0
1954	0
1959	0
1964	Fill
1966	0
1970	0
1980	0
1981	0
1985	0
1986	0
1990	0
1998	0
2002	0
2004	0
2005	12
2006	0
2007	0
2010	Fill
2013	0
2016	0
2018	0
2019	0

*Willamette Valley System Operations and Maintenance
Environmental Impact Statement*

Abundant Year	KAF
1944	3
1965	0
1967	2
1968	0
1978	3
1987	0
1992	0
1994	0
Deficit Year	KAF
1941	7
1942	0
1973	7
1977	15
2001	9
2015	0

* Increase of 0 reported if the baseline reaches the rule curve after exceeding the secondary flood pool.

Cougar Dam and Reservoir:

Table 9-11 indicates the estimated increase in maximum conservation storage resulting from guaranteeing refill to the top of the secondary flood pool during spring refill at Cougar Dam and Reservoir. Secondary flood pool volume at Cougar Dam and Reservoir is 22 kaf, which is approximately 16 percent of the total 136 kaf of conservation storage capacity.

Cougar Reservoir fills in 89 percent (40 of 45) of Abundant water years in the baseline and therefore cannot realize a benefit from the alternative operations. In the remaining 11 percent (5 of 45) of the abundant water years, there is no increase in storage resulting from the alternative operation. The alternative operation results in higher reservoir storage in 52 percent (13 of 25) adequate water years, with an average increase of 6.4 kaf which is equivalent to 107 cfs released over 30 days. The alternative operation results in higher reservoir storage in 75 percent (6 of 8) of Insufficient water years with an average increase of 10.2 kaf which is equivalent to 172 cfs released over 30 days. The alternative operation results in higher reservoir storage in 83 percent (5 of 6) of Deficit water years with an average increase of 10.3 kaf, which is equivalent to 172 cfs released over 30 days.

Increases in storage resulting from alternative operations 1966, 1985, and 1991 decrease significantly later in the season as a result of Cougar Dam and Reservoir drafting to stay below the rule curve in the alternative while pool elevations rise in the baseline.

Table 9-11. April Increase in Conservation Storage Associated with Alternative Operations at Cougar Dam and Reservoir (“Fill” means that the reservoir fills under the baseline).

Abundant Year	KAF
1936	Fill
1937	Fill
1938	Fill
1943	Fill
1945	Fill
1948	Fill
1949	Fill
1950	Fill
1951	Fill
1952	Fill
1953	Fill
1955	Fill
1956	Fill
1957	0
1958	0
1960	Fill
1961	Fill
1962	Fill
1963	Fill
1969	Fill
1971	Fill
1972	Fill
1974	Fill
1975	Fill
1976	Fill
1979	Fill
1982	Fill
1983	Fill
1984	Fill
1988	Fill
1989	0
1991	13
1993	Fill
1995	Fill
1996	Fill
1997	Fill
1999	Fill

*Willamette Valley System Operations and Maintenance
Environmental Impact Statement*

Abundant Year	KAF
2000	Fill
2003	Fill
2008	Fill
2009	Fill
2011	Fill
2012	Fill
2014	Fill
2017	Fill
Adequate Year	KAF
1939	0
1940	0
1946	Fill
1947	0
1954	2
1959	12
1964	Fill
1966	20
1970	7
1980	15
1981	4
1985	22
1986	0
1990	0
1998	13
2002	0
2004	8
2005	22
2006	11
2007	0
2010	Fill
2013	14
2016	0
2018	11
2019	0
Insufficient Year	KAF
1944	11
1965	0
1967	11
1968	0
1978	11
1987	8

*Willamette Valley System Operations and Maintenance
Environmental Impact Statement*

Abundant Year	KAF
1992	20
1994	22
Deficit Year	KAF
1941	15
1942	1
1973	19
1977	0
2001	20
2015	7

* Increase of 0 reported if the baseline reaches the rule curve after exceeding the secondary flood pool.

Detroit Dam and Reservoir:

Table 9-12 indicates the estimated increase in maximum conservation storage resulting from guaranteeing refill to the top of the secondary flood pool during spring refill at Detroit Dam and Reservoir. The secondary flood pool volume at Detroit Dam and Reservoir is 62 kaf, which is approximately 22 percent of the total 280 kaf of conservation storage capacity.

Detroit Reservoir fills in all Abundant water years in the baseline and therefore cannot realize a benefit from the alternative operations. The alternative operation results in higher reservoir storage in 16 percent (4 of 25) of Adequate water years with an average increase of 4.1 kaf, which is equivalent to 67 cfs released over 30 days. The alternative operation results in higher reservoir storage in 75 percent (6 of 8) of Insufficient water years with an average increase of 18.5 kaf which is equivalent to 310 cfs released over 30 days. The alternative operation results in higher reservoir storage in 67 percent (4 of 6) Deficit water years with a median increase of 25.2 kaf which is equivalent to 422 cfs released over 30 days.

Table 9-12. April Increase in Conservation Storage Associated with Alternative Operations at Detroit Dam and Reservoir (“Fill” means that the reservoir fills under the baseline).

Abundant Year	KAF
1936	Fill
1937	Fill
1938	Fill
1943	Fill
1945	Fill
1948	Fill
1949	Fill
1950	Fill
1951	Fill
1952	Fill

*Willamette Valley System Operations and Maintenance
Environmental Impact Statement*

Abundant Year	KAF
1953	Fill
1955	Fill
1956	Fill
1957	Fill
1958	Fill
1960	Fill
1961	Fill
1962	Fill
1963	Fill
1969	Fill
1971	Fill
1972	Fill
1974	Fill
1975	Fill
1976	Fill
1979	Fill
1982	Fill
1983	Fill
1984	Fill
1988	Fill
1989	Fill
1991	Fill
1993	Fill
1995	Fill
1996	Fill
1997	Fill
1999	Fill
2000	Fill
2003	Fill
2008	Fill
2009	Fill
2011	Fill
2012	Fill
2014	Fill
2017	Fill
Adequate Year	KAF
1939	Fill
1940	0
1946	Fill
1947	3
1954	Fill

*Willamette Valley System Operations and Maintenance
Environmental Impact Statement*

Abundant Year	KAF
1959	Fill
1964	Fill
1966	Fill
1970	0
1980	25
1981	0
1985	Fill
1986	0
1990	Fill
1998	Fill
2002	Fill
2004	Fill
2005	58
2006	Fill
2007	0
2010	Fill
2013	Fill
2016	0
2018	15
2019	0
Insufficient Year	KAF
1944	36
1965	0
1967	24
1968	0
1978	7
1987	4
1992	20
1994	58
Deficit Year	KAF
1941	46
1942	1
1973	51
1977	0
2001	53
2015	0

* Increase of 0 reported if the baseline reaches the rule curve after exceeding the secondary flood pool.

Green Peter Dam and Reservoir:

Table 9-13 indicates the estimated increase in maximum conservation storage resulting from guaranteeing refill to the top of the secondary flood pool during spring refill at Green Peter

*Willamette Valley System Operations and Maintenance
Environmental Impact Statement*

Dam and Reservoir. The secondary flood pool volume at Green Peter Dam and Reservoir is 70 kaf, which is approximately 28 percent of the total 250 kaf of conservation storage capacity.

Green Peter Reservoir fills in nearly all Abundant and Adequate water years in the baseline and therefore cannot realize a benefit from the alternative operations. The alternative operation results in higher reservoir storage in 50 percent (4 of 8) Insufficient water years with an average increase of 7.3 kaf, which is equivalent to 122 cfs released over 30 days. The alternative operation results in higher reservoir storage in 83 percent (5 of 6) of Deficit water years with an average increase of 35.6 kaf which is equivalent to 597 cfs released over 30 days.

Table 9-13. April Increase in Conservation Storage Associated with Alternative Operations at Green Peter Dam and Reservoir (“Fill” means that the reservoir fills under the baseline).

Abundant Year	KAF
1936	Fill
1937	Fill
1938	Fill
1943	Fill
1945	Fill
1948	Fill
1949	Fill
1950	Fill
1951	Fill
1952	Fill
1953	Fill
1955	Fill
1956	Fill
1957	Fill
1958	Fill
1960	Fill
1961	Fill
1962	Fill
1963	Fill
1969	Fill
1971	Fill
1972	Fill
1974	Fill
1975	Fill
1976	Fill
1979	Fill
1982	Fill
1983	Fill

*Willamette Valley System Operations and Maintenance
Environmental Impact Statement*

Abundant Year	KAF
1984	Fill
1988	Fill
1989	Fill
1991	Fill
1993	Fill
1995	Fill
1996	Fill
1997	Fill
1999	Fill
2000	Fill
2003	Fill
2008	Fill
2009	Fill
2011	Fill
2012	Fill
2014	Fill
2017	Fill
1939	0
1940	0
1946	Fill
1947	0
1954	Fill
1959	Fill
1964	Fill
1966	Fill
1970	Fill
1980	0
1981	Fill
1985	Fill
1986	Fill
1990	Fill
1998	Fill
2002	Fill
2004	Fill
2005	Fill
2006	Fill
2007	0
2010	Fill
2013	Fill
2016	0
2018	0

*Willamette Valley System Operations and Maintenance
Environmental Impact Statement*

Abundant Year	KAF
2019	0
Insufficient Year	KAF
1944	20
1965	0
1967	20
1968	0
1978	15
1987	0
1992	3
1994	0
Deficit Year	KAF
1941	52
1942	8
1973	70
1977	Fill
2001	70
2015	14

* Increase of 0 reported if the baseline reaches the rule curve after exceeding the secondary flood pool.

Hills Creek Dam and Reservoir:

Table 9-14 indicates the estimated increase in maximum conservation storage resulting from guaranteeing refill to the top of the secondary flood pool during spring refill at Hills Creek Dam and Reservoir. The secondary flood pool volume at Hills Creek Dam and Reservoir is 56 kaf, which is approximately 29 percent of the total 195 kaf of conservation storage.

Hills Creek Reservoir fills in nearly all Abundant water years in the baseline and therefore cannot realize a benefit from the alternative operations. The alternative operation results in higher reservoir storage in 36 percent (9 of 25) of Adequate water years with an average increase of 8.5 kaf which is equivalent to 142 cfs released over 30 days. The alternative operation results in higher reservoir storage in 63 percent (5 of 8) of Insufficient water years with an average increase of 20.6 kaf which is equivalent to 344 cfs released over 30 days. The alternative operation results in higher reservoir storage in 100 percent (6 of 6) of Deficit water years with a median increase of 32.2 kaf, which is equivalent to 539 cfs released over 30 days.

Increases in storage resulting from alternative operations in 1959 and 1985 decrease significantly later in the season as a result of Hills Creek Dam and Reservoir drafting to stay below the rule curve in the alternative while pool elevations rise in the baseline.

Table 9-14. April Increase in Conservation Storage Associated with Alternative Operations at Hills Creek Dam and Reservoir (“Fill” means that the reservoir fills under the baseline).

Abundant Year	KAF
1936	Fill
1937	Fill
1938	Fill
1943	Fill
1945	Fill
1948	Fill
1949	Fill
1950	Fill
1951	Fill
1952	Fill
1953	Fill
1955	Fill
1956	Fill
1957	0
1958	0
1960	Fill
1961	Fill
1962	Fill
1963	Fill
1969	Fill
1971	Fill
1972	Fill
1974	Fill
1975	Fill
1976	Fill
1979	Fill
1982	Fill
1983	Fill
1984	Fill
1988	Fill
1989	0
1991	16
1993	Fill
1995	Fill
1996	Fill
1997	Fill
1999	Fill

*Willamette Valley System Operations and Maintenance
Environmental Impact Statement*

Abundant Year	KAF
2000	Fill
2003	0
2008	Fill
2009	Fill
2011	Fill
2012	Fill
2014	Fill
2017	Fill
Adequate Year	KAF
1939	0
1940	0
1946	0
1947	0
1954	0
1959	18
1964	Fill
1966	0
1970	0
1980	25
1981	21
1985	31
1986	0
1990	6
1998	0
2002	0
2004	3
2005	51
2006	0
2007	0
2010	Fill
2013	24
2016	0
2018	33
2019	0
Insufficient Year	KAF
1944	31
1965	0
1967	21
1968	0
1978	0
1987	13

*Willamette Valley System Operations and Maintenance
Environmental Impact Statement*

Abundant Year	KAF
1992	46
1994	54
Deficit Year	KAF
1941	38
1942	16
1973	41
1977	31
2001	50
2015	17

* Increase of 0 reported if the baseline reaches the rule curve after exceeding the secondary flood pool.

Lookout Point Dam and Reservoir:

Table 9-15 indicates the estimated increase in maximum conservation storage resulting from guaranteeing refill to the top of the secondary flood pool during spring refill at Lookout Point Dam and Reservoir. The secondary flood pool volume at Lookout Point Dam and Reservoir is 75 kaf, which is approximately 23 percent of the total 325 kaf of conservation storage capacity.

Lookout Point Reservoir fills in nearly all Abundant and Adequate water years in the baseline and therefore cannot realize a benefit from the alternative operations. The alternative operation results in higher reservoir storage in 50 percent (4 of 8) of Insufficient water years with an average observed increase of 24.9 kaf, which is equivalent to 417 cfs released over 30 days. The alternative operation results in higher reservoir storage in 67 percent (4 of 6) of Deficit water years with an average observed increase of 33.0 kaf which is equivalent to 554 cfs released over 30 days.

Increases in storage resulting from alternative operations 1944, 2001, and 2005 decrease significantly later in the season as a result of Lookout Point Reservoir drafting to stay below the rule curve in the alternative while pool elevations rise in the baseline.

Table 9-15. April Increase in Conservation Storage Associated with Alternative Operation at Lookout Point Dam and Reservoir (“Fill” means that the reservoir fills under the baseline).

Abundant Year	KAF
1936	Fill
1937	Fill
1938	Fill
1943	Fill
1945	Fill
1948	Fill
1949	Fill
1950	Fill

*Willamette Valley System Operations and Maintenance
Environmental Impact Statement*

Abundant Year	KAF
1951	Fill
1952	Fill
1953	Fill
1955	Fill
1956	Fill
1957	Fill
1958	Fill
1960	Fill
1961	Fill
1962	Fill
1963	Fill
1969	Fill
1971	Fill
1972	Fill
1974	Fill
1975	Fill
1976	Fill
1979	Fill
1982	Fill
1983	Fill
1984	Fill
1988	Fill
1989	Fill
1991	Fill
1993	Fill
1995	Fill
1996	Fill
1997	Fill
1999	Fill
2000	Fill
2003	Fill
2008	Fill
2009	Fill
2011	Fill
2012	Fill
2014	Fill
2017	Fill
Adequate Year	KAF
1939	Fill
1940	0
1946	Fill

*Willamette Valley System Operations and Maintenance
Environmental Impact Statement*

Abundant Year	KAF
1947	Fill
1954	Fill
1959	Fill
1964	Fill
1966	Fill
1970	Fill
1980	Fill
1981	Fill
1985	Fill
1986	Fill
1990	Fill
1998	Fill
2002	Fill
2004	Fill
2005	70
2006	Fill
2007	Fill
2010	Fill
2013	Fill
2016	0
2018	54
2019	Fill
Insufficient Year	KAF
1944	30
1965	Fill
1967	Fill
1968	0
1978	0
1987	28
1992	67
1994	74
Deficit Year	KAF
1941	55
1942	0
1973	60
1977	20
2001	62
2015	0

* Increase of 0 reported if the baseline reaches the rule curve after exceeding the secondary flood pool.

*Willamette Valley System Operations and Maintenance
Environmental Impact Statement*

System:

Table 9-16 indicates the estimated increase in conservation storage resulting from guaranteeing refill to the top of the secondary flood pool during spring refill at all six WVS reservoirs with secondary flood pools. The system secondary flood pool volume at is 300 kaf, which is approximately 19 percent of the total 1,590 kaf of conservation storage capacity.

WVS reservoirs fill in nearly all Abundant water years in the baseline and therefore cannot realize a benefit from the alternative operations. The alternative operation results in higher reservoir storage in 60 percent (15 of 25) of Adequate water years with an average observed increase of 5 kaf which is equivalent to 83 cfs released over 30 days. The alternative operation results in higher reservoir storage in 6 of 7 Insufficient water years with an average observed increase of 82.5 kaf, which is equivalent to 1,383 cfs released over 30 days. The alternative operation results in higher reservoir storage in 100 percent (6 of 6) Insufficient water years with an average observed increase of 144 kaf which is equivalent to 2,993 cfs released over 30 days.

Increases in storage resulting from alternative operations 1944, 1959, 1966, 1985, 1991, 2001, and 2005 decrease significantly later in the season as a result of WVS reservoirs drafting to stay below the rule curve in the alternative while pool elevations rise in the baseline.

Table 9-16. April Increase in Conservation Storage Associated with Alternative Operation at WVS Reservoirs with Secondary Flood Pools.

Abundant Year	KAF
1936	0
1937	0
1938	0
1943	0
1945	0
1948	0
1949	0
1950	0
1951	0
1952	0
1953	0
1955	0
1956	0
1957	0
1958	0
1960	0
1961	0
1962	0
1963	0
1969	0

*Willamette Valley System Operations and Maintenance
Environmental Impact Statement*

Abundant Year	KAF
1971	0
1972	0
1974	0
1975	0
1976	0
1979	0
1982	0
1983	0
1984	0
1988	0
1989	0
1991	29
1993	0
1995	0
1996	0
1997	0
1999	0
2000	0
2003	0
2008	0
2009	0
2011	0
2012	0
2014	0
2017	0
Adequate Year	KAF
1939	0
1940	0
1946	0
1947	3
1954	2
1959	30
1964	0
1966	20
1970	7
1980	65
1981	26
1985	53
1986	0
1990	6
1998	13

*Willamette Valley System Operations and Maintenance
Environmental Impact Statement*

Abundant Year	KAF
2002	0
2004	11
2005	213
2006	11
2007	0
2010	0
2013	38
2016	0
2018	112
2019	0
Insufficient Year	KAF
1944	130
1965	0
1967	78
1968	0
1978	36
1987	53
1992	155
1994	208
Deficit Year	KAF
1941	214
1942	25
1973	249
1977	66
2001	264
2015	37

* Increase of 0 reported if the baseline reaches the rule curve after exceeding the secondary flood pool.

9.3 Conclusions

The proposed alternative operation targets the top of the secondary flood pool throughout the winter with the hopes that starting refill season with a higher baseline storage will maximum conservation season storage. However, in many years the reservoirs with secondary flood pools fill to the top of the secondary flood pool by the target date even when starting from the minimum conservation elevation (Figure 9-1(a)). In other years, when starting at the secondary flood pool provides a head start on refill, the reservoirs may fill to the rule curve without the head start (Figure 9-2(b)). Increases in conservation season storage are observed in the remaining years when storage differences between the baseline and alternative resemble Figure 9-2(c).

*Willamette Valley System Operations and Maintenance
Environmental Impact Statement*

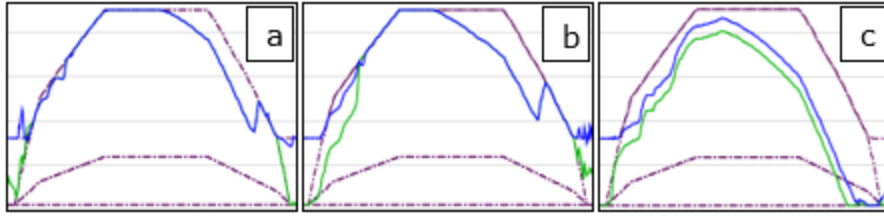

Figure 9-2. Refill Scenarios – Green = Baseline, Blue = Alternative.

The number of years an increase in storage is observed as a result of the alternative operations, and the median increase observed in those years is presented in Table 9-17. In abundant water years, no significant increases in conservation storage resulting from the alternative operations are realized because reservoirs generally fill without the benefit of starting refill at the top of the secondary flood pool. In adequate water years, reservoirs rarely completely fill under normal operations, but most commonly fill to the rule curve by the end of March. Cougar Dam and Reservoir is a notable exception, where increased storage resulting from alternative operations is observed in over half of Adequate water years. In Insufficient and Deficit water years, all six reservoirs exhibit increases in storage as a result of the alternative operations.

Average increases in Deficit water years at individual reservoirs range from 7 percent of maximum conservation storage capacity at Cougar Reservoir to 16 percent of maximum conservation storage capacity at Hills Creek Reservoir. Average increases in system storage in insufficient years represent roughly 7 percent of total system storage, and 11 percent in Deficit years. One kaf of storage can provide a flow of 17 cfs for 30 days.

If minimum flow targets remain the same as in the baseline No-action model, 01 May increases will be significantly less than 01 April increases observed in the years 1944, 1959, 1966, 1985, 1991, 2001, and 2005, which will affect the values in Table 9-9. In these years, reservoirs fill in the alternative, but not in the baseline. Consequently, baseline storage increases while storage is drafted in the alternative. These values were not edited because alternative flow regimes that draw more water early in the season can prevent the reservoirs from filling and spilling in the alternative, and 01 April increases will remain representative of the maximum benefit to conservation season storage.

Table 9-17. Number of Years with Increased Storage Attributed to Alternative Operations and Average Increase by Water Year Type.

Reservoir	Abundant Years with Increase out of 45 (% of year type)	Mean kaf Increase (30-day cfs equivalent)
Blue River	0 (0)	0 (0)
Cougar	1 (2)	0.3 (5)
Detroit	0 (0)	0 (0)
Green Peter	0 (0)	0 (0)
Hills Creek	1 (2)	0.4 (7)
Lookout Point	0 (0)	0 (0)

*Willamette Valley System Operations and Maintenance
Environmental Impact Statement*

Reservoir	Abundant Years with Increase out of 45 (% of year type)	Mean kaf Increase (30-day cfs equivalent)
System	1 (2)	0.7 (12)
Reservoir	Adequate Years with Increase out of 25 (% of year type)	Mean kaf Increase (30-day cfs equivalent)
Blue River	1 (4)	0.5 (8)
Cougar	13 (52)	6.4 (107)
Detroit	4 (16)	4.1 (67)
Green Peter	0 (0)	0 (0)
Hills Creek	9 (36)	8.5(142)
Lookout Point	2 (8)	5.0 (83)
System	15 (60)	24.3(408)
Reservoir	Insufficient Years with Increase out of 8 (% of year type)	Mean kaf Increase (30-day cfs equivalent)
Blue River	3 (38)	1.1 (18)
Cougar	6 (75)	10.2(172)
Detroit	6 (75)	18.5 (310)
Green Peter	4 (50)	7.3 (122)
Hills Creek	5 (63)	20.6 (344)
Lookout Point	4 (50)	24.9 (417)
System	6 (75)	82.5 (1,383)
Reservoir	Deficit Years with Increase out of 6 (% of year type)	Mean kaf Increase (30-day cfs equivalent)
Blue River	4 (67)	6.4 (107)
Cougar	5 (83)	10.3 (172)
Detroit	4 (67)	25.2 (422)
Green Peter	5 (83)	35.6 (597)
Hills Creek	6 (100)	32.2 (539)
Lookout Point	4 (67)	33.0 (554)
System	6 (100)	142 (2,393)

* Increases observed on 01 April. Increase of 0 reported if the baseline reaches the rule curve after exceeding the secondary flood pool.

10 WVS WATER CONTROL DIAGRAMS

This section contains water control diagrams which include the authorized conservation season target and other pertinent elevations. Elevations are in project datum, which is very nearly the same as NGVD29 at most projects. Table 10-1 shows conversions between project datums and NAVD88.

Willamette Valley System Operations and Maintenance
Environmental Impact Statement

Table 10-1. Project Datum Conversions (USACE 2018b).

USACE Dam and Reservoir	NAD 1983 North Latitude	NAD 1983 West Longitude	Convert an elevation from Project Datum ¹ to NAVD88	Convert an elevation from NAVD88 to Project Datum ¹	Date Updated
Big Cliff	44.751	122.283	4.16	-4.16	March 2014
Blue River	44.173	122.329	3.84	-3.84	September 2014
Cottage Grove	43.716	123.053	4.11	-4.11	September 2014
Cougar	44.128	122.241	3.42	-3.42	September 2017
Detroit	44.722	122.25	4.23	-4.23	October 2017
Dexter	43.921	122.809	3.41	-3.41	March 2014
Dorena	43.783	122.955	3.81	-3.81	September 2014
Fall Creek	43.947	122.757	3.78	-3.78	September 2014
Fern Ridge	44.118	123.29	3.5	-3.5	September 2014
Foster	44.413	122.67	3.65	-3.65	April 2009
Green	44.45	122.55	3.65	-3.65	April 2009
Hills Creek	43.709	122.425	3.82	-3.82	March 2014
Lookout Point	43.913	122.752	3.52	-3.52	March 2014

¹ Site-specific 'Project Datums' are based on NGVD29 at most sites, but there are exceptions.

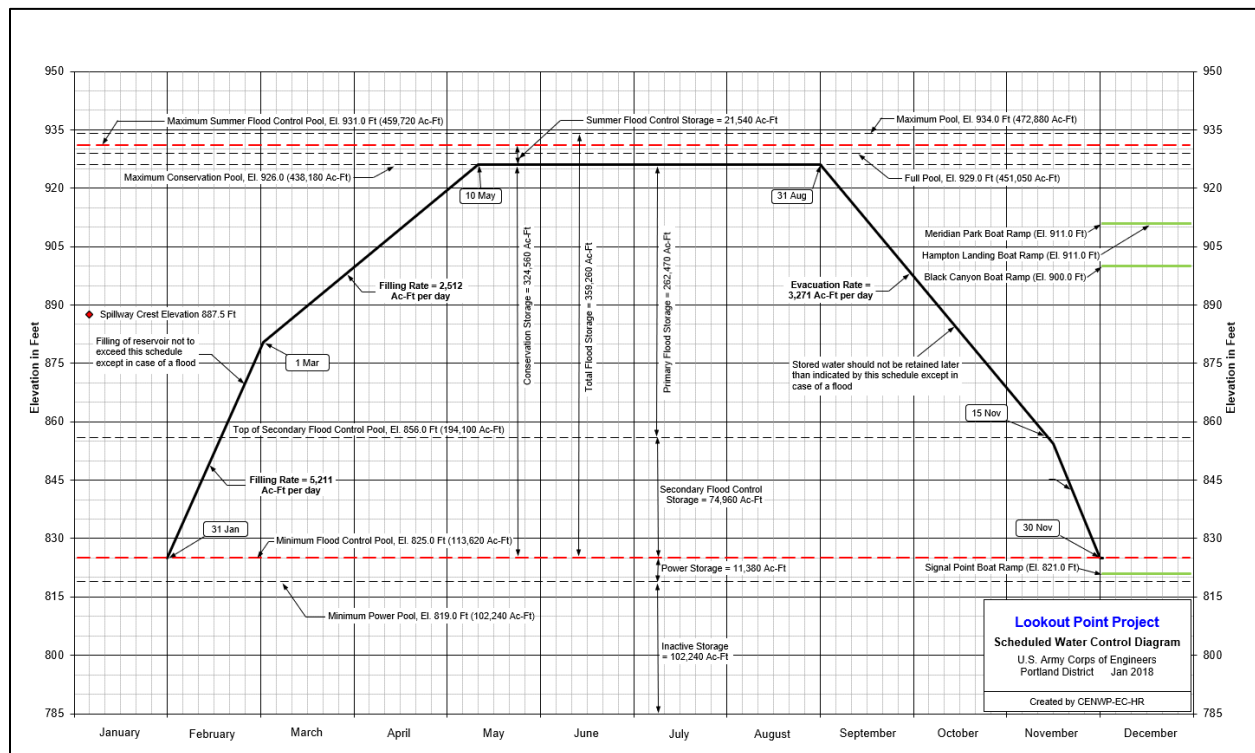

Figure 10-1. Lookout Point Dam and Reservoir Water Control Diagram.

*Willamette Valley System Operations and Maintenance
Environmental Impact Statement*

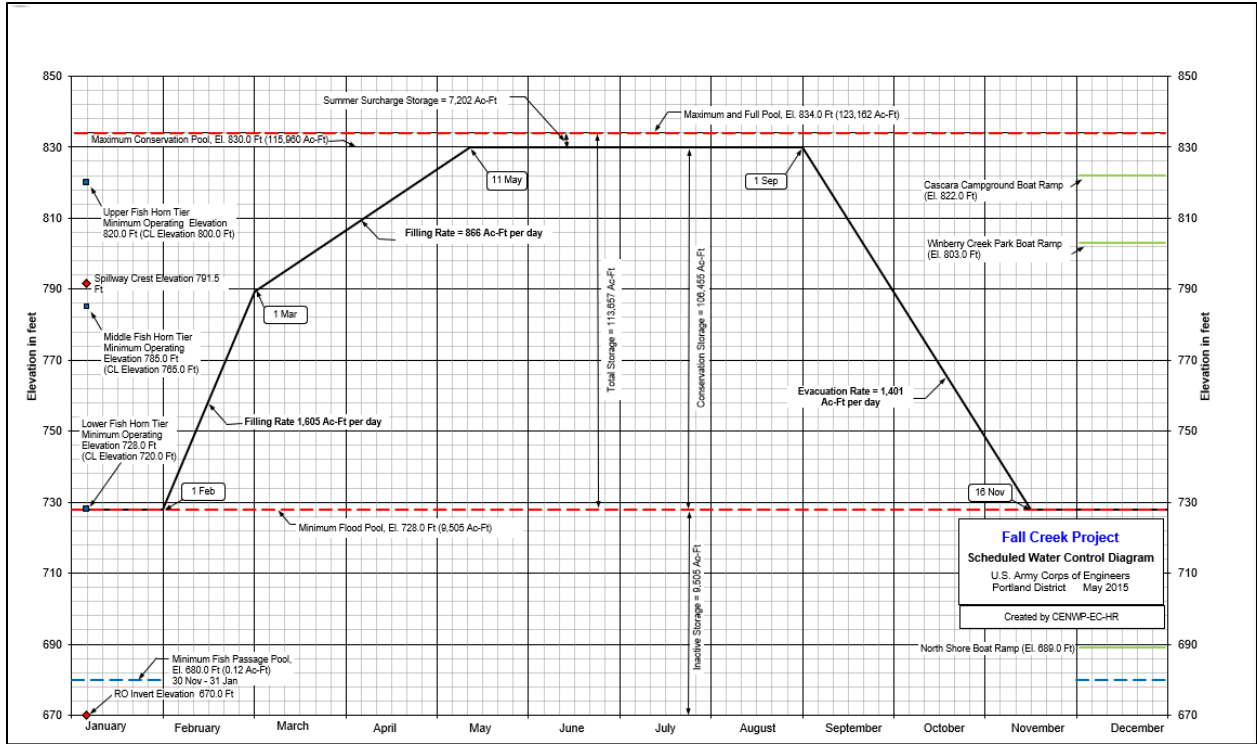

Figure 10-2. Fall Creek Dam and Reservoir Water Control Diagram.

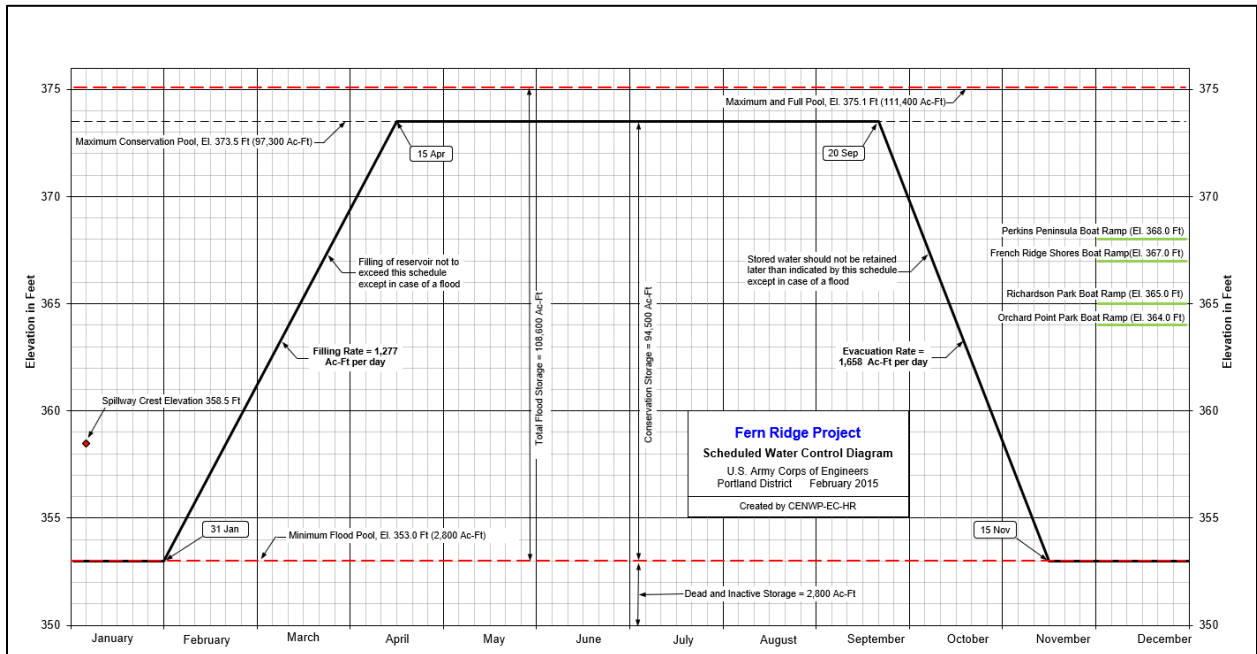

Figure 10-3. Fern Ridge Dam and Reservoir Water Control Diagram.

*Willamette Valley System Operations and Maintenance
Environmental Impact Statement*

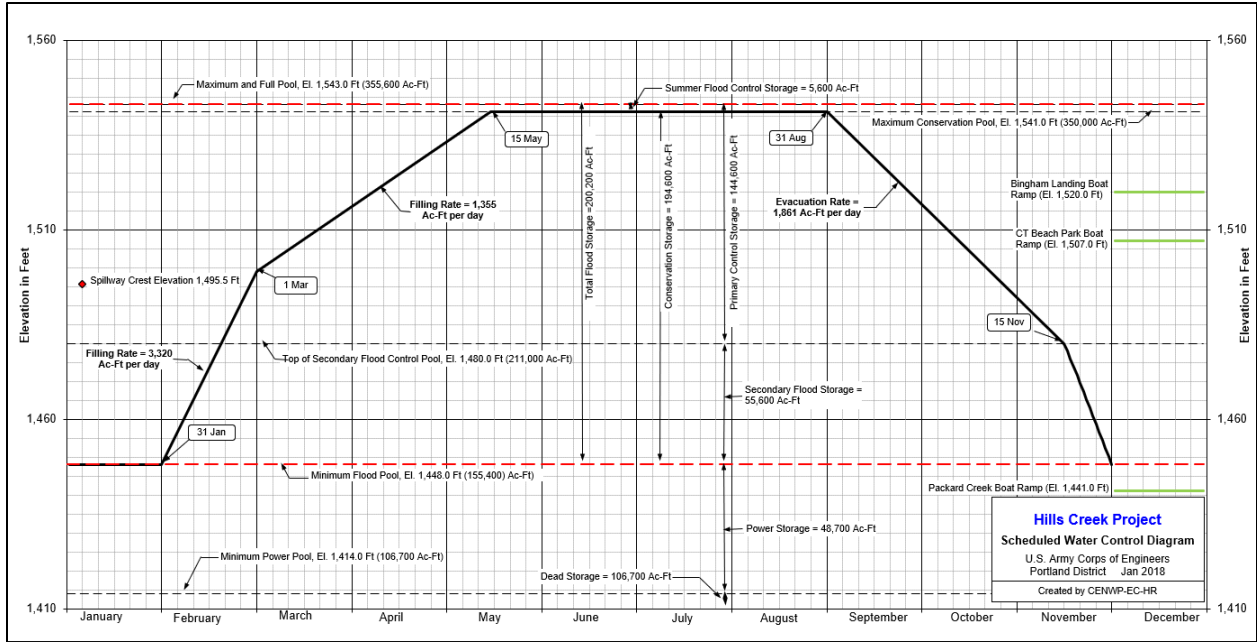

Figure 10-4. Hills Creek Dam and Reservoir Water Control Diagram.

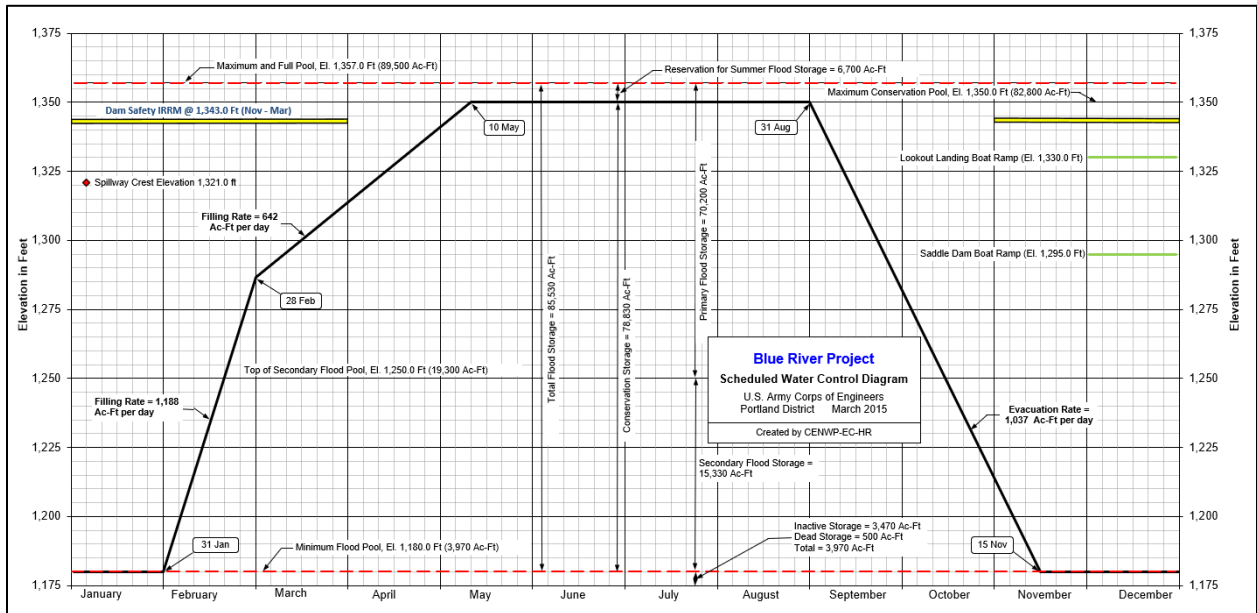

Figure 10-5. Blue River Dam and Reservoir Water Control Diagram.

**Willamette Valley System Operations and Maintenance
Environmental Impact Statement**

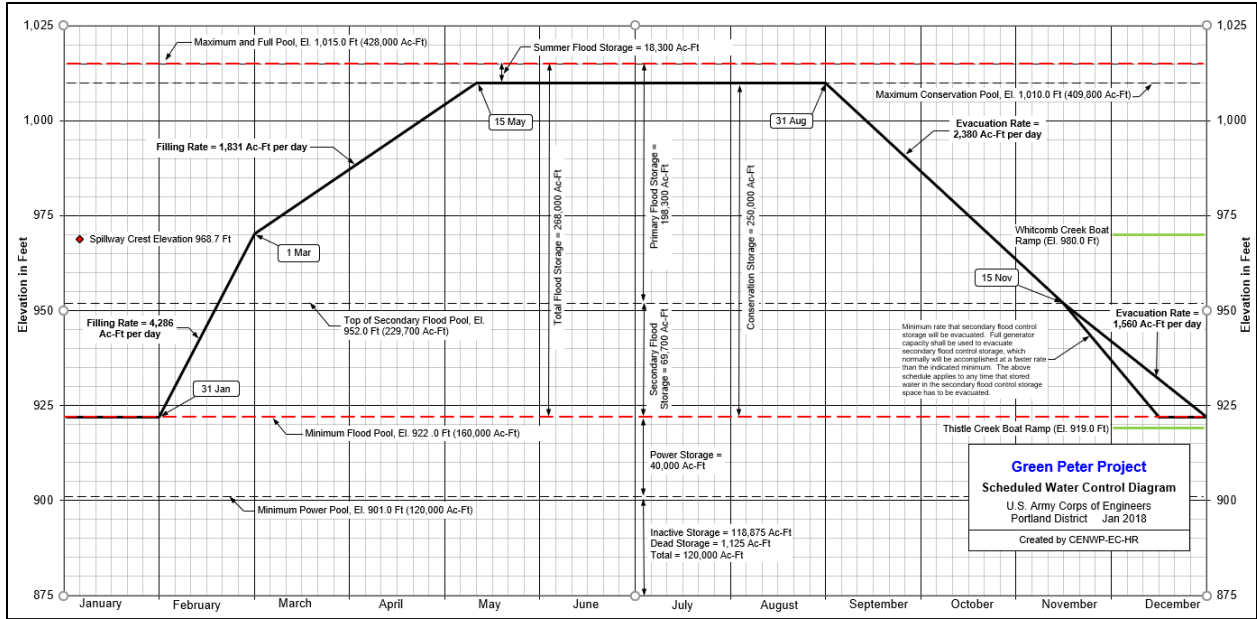

Figure 10-6. Green Peter Dam and Reservoir Water Control Diagram.

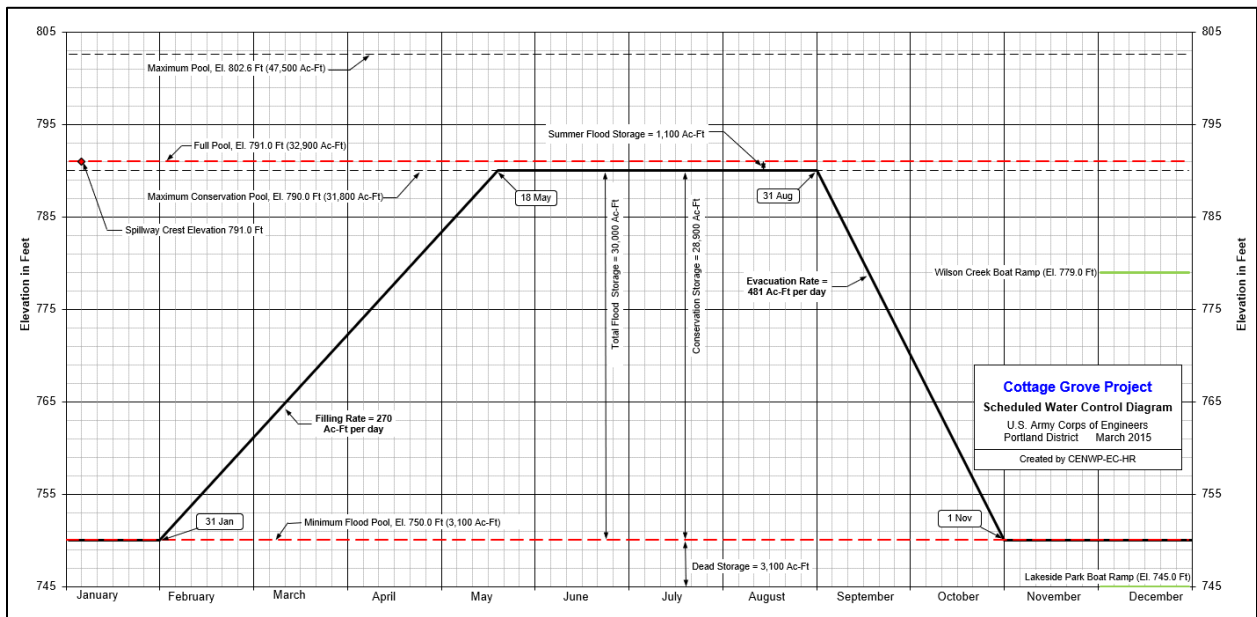

Figure 10-7. Cottage Grove Dam and Reservoir Water Control Diagram.

*Willamette Valley System Operations and Maintenance
Environmental Impact Statement*

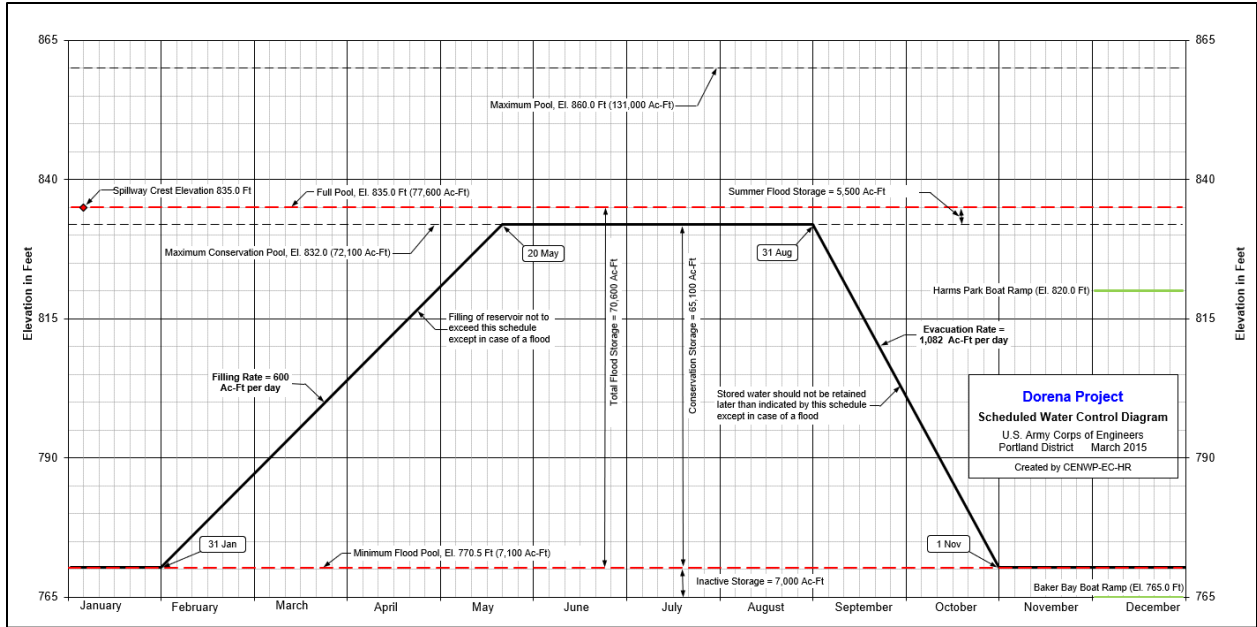

Figure 10-8. Dorena Dam and Reservoir Water Control Diagram.

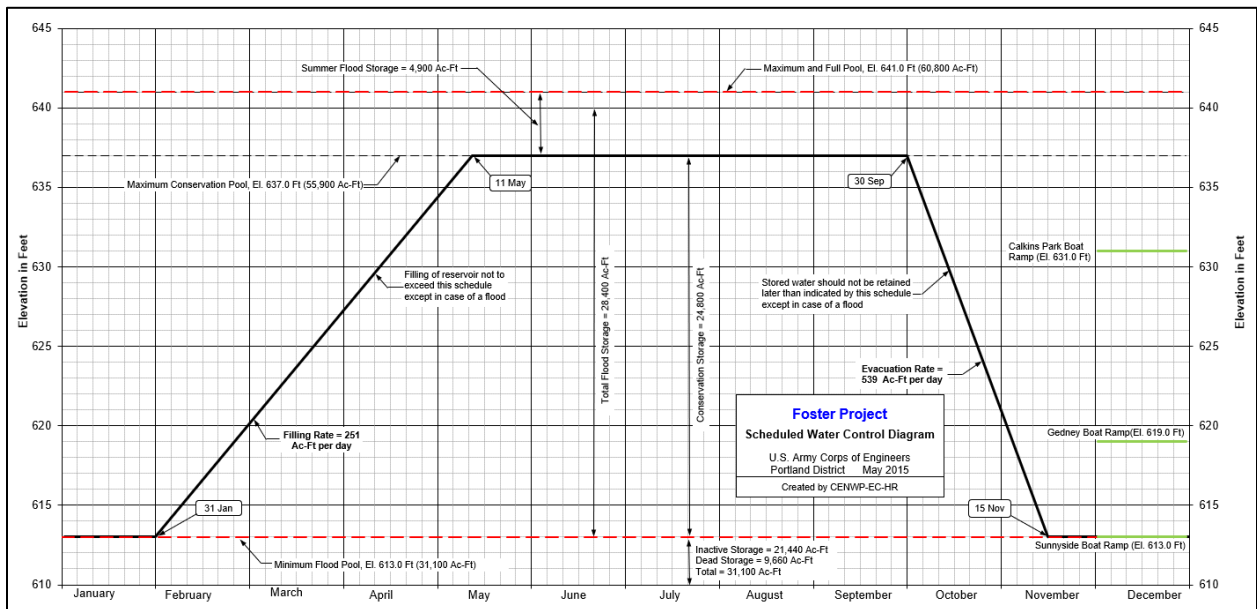

Figure 10-9. Foster Dam and Reservoir Water Control Diagram.

*Willamette Valley System Operations and Maintenance
Environmental Impact Statement*

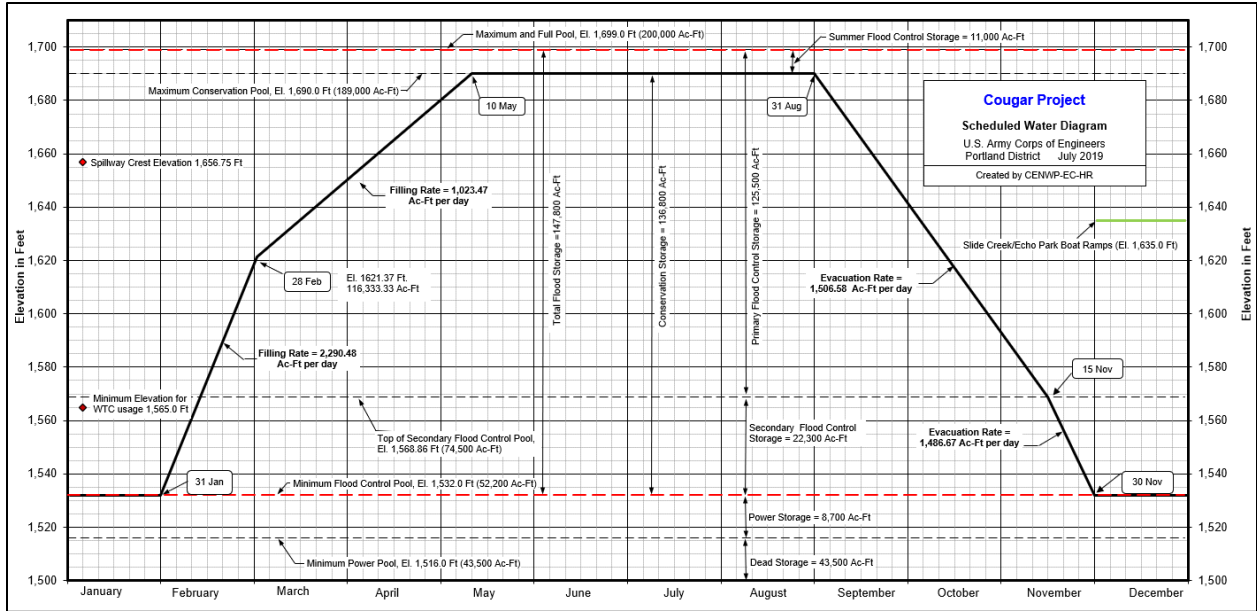

Figure 10-10. Cougar Dam and Reservoir Water Control Diagram.

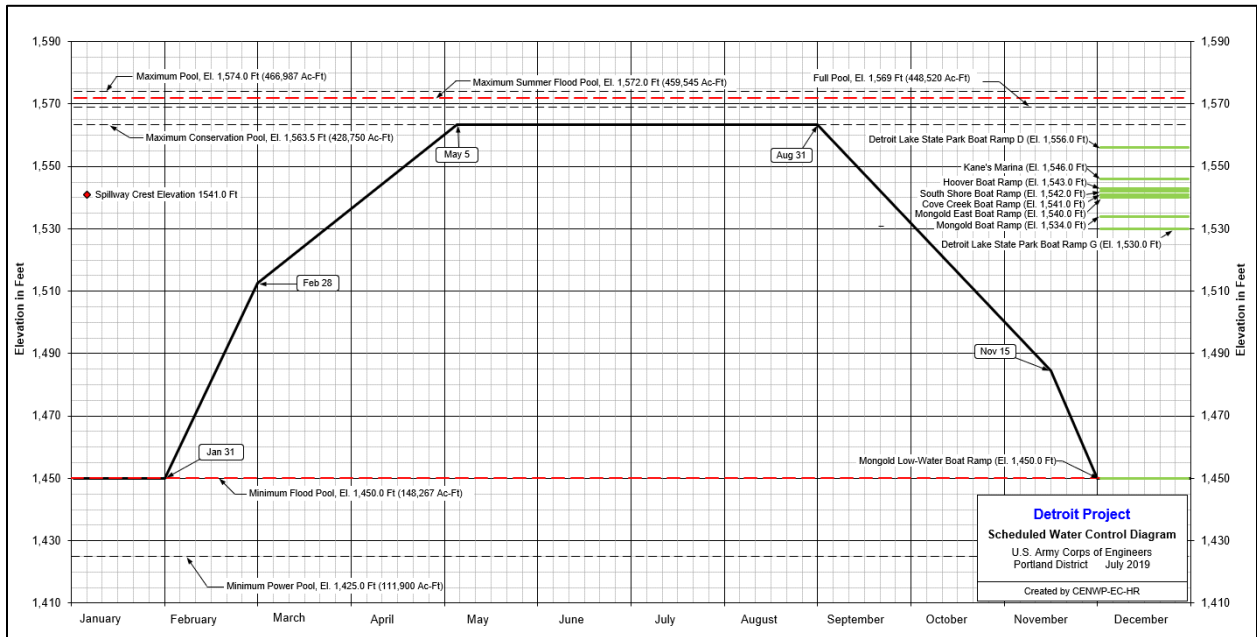

Figure 10-11. Detroit Dam and Reservoir Water Control Diagram.

*Willamette Valley System Operations and Maintenance
Environmental Impact Statement*

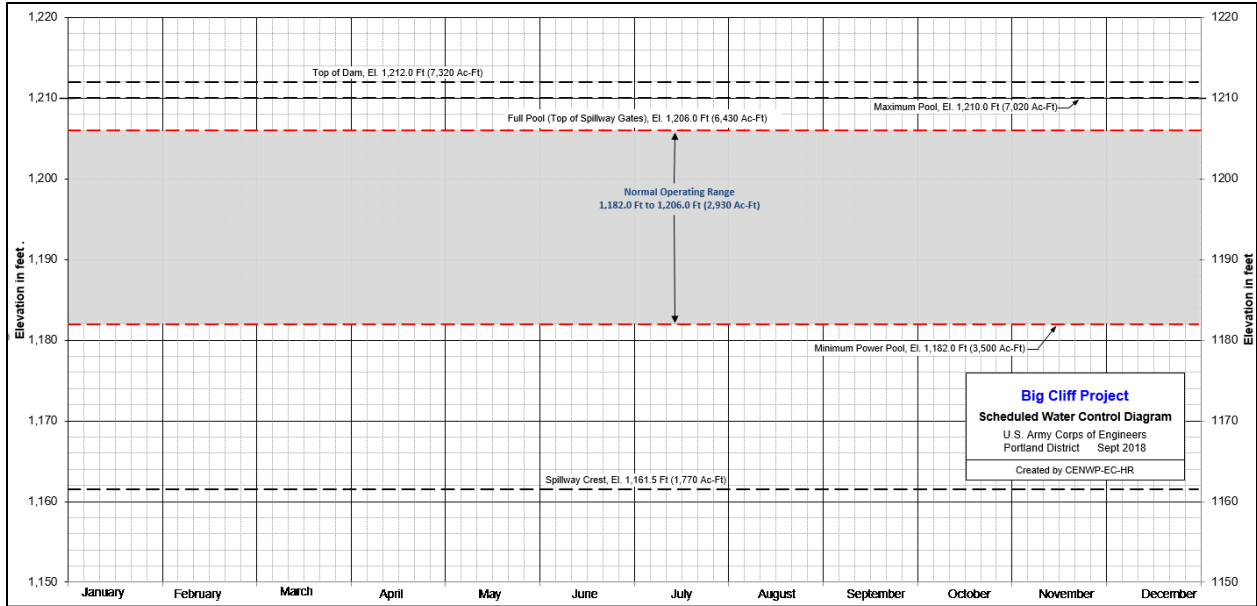

Figure 10-12. Big Cliff Dam and Reservoir Water Control Diagram.

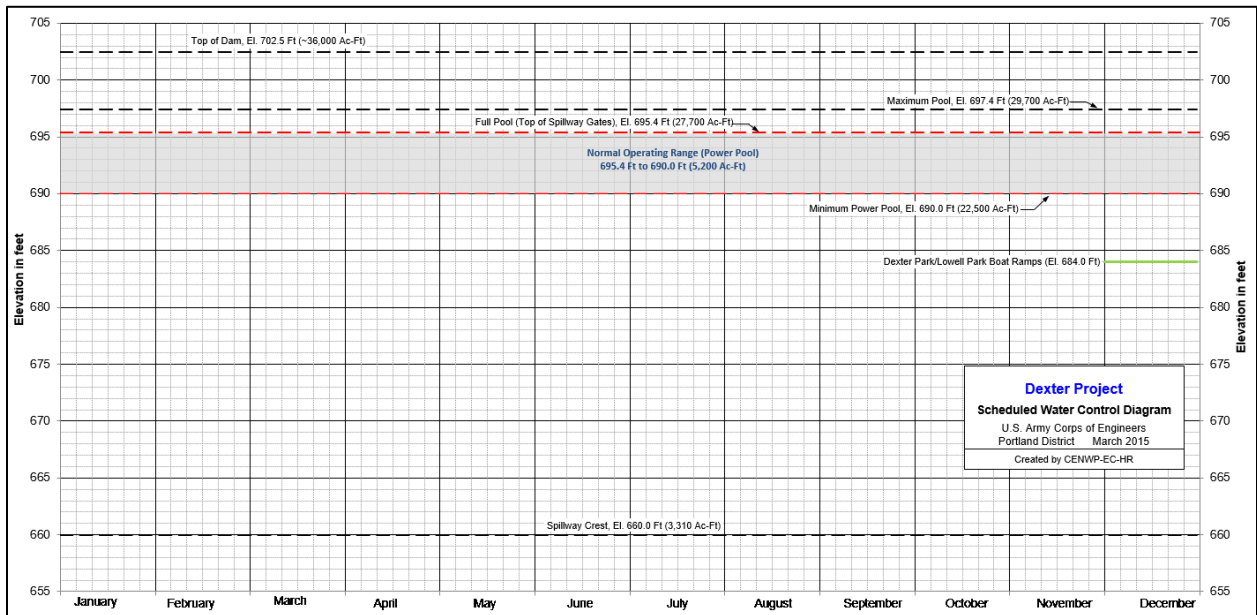

Figure 10-13. Dexter Dam and Reservoir Water Control Diagram.

11 BASIN DESCRIPTION SUPPLEMENTARY FIGURES

The following figures are those not included in FEIS Section 3.2.1.5.2, Unregulated and Observed Flow. All flow figures below represent water years 1935 to 2019, with the observed data only shown for years after all upstream reservoirs had been constructed (year varies).

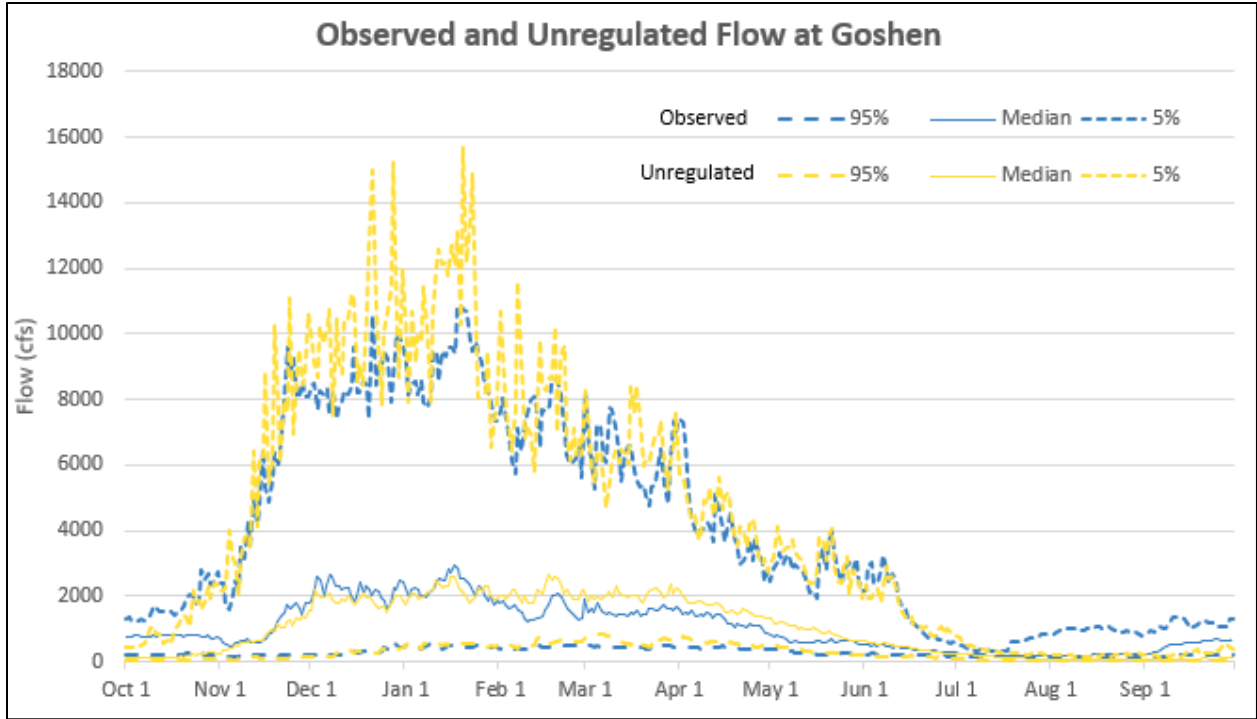

Figure 11-1. Coast Fork of the Willamette River at Goshen, OR. Flows across the Water Year.

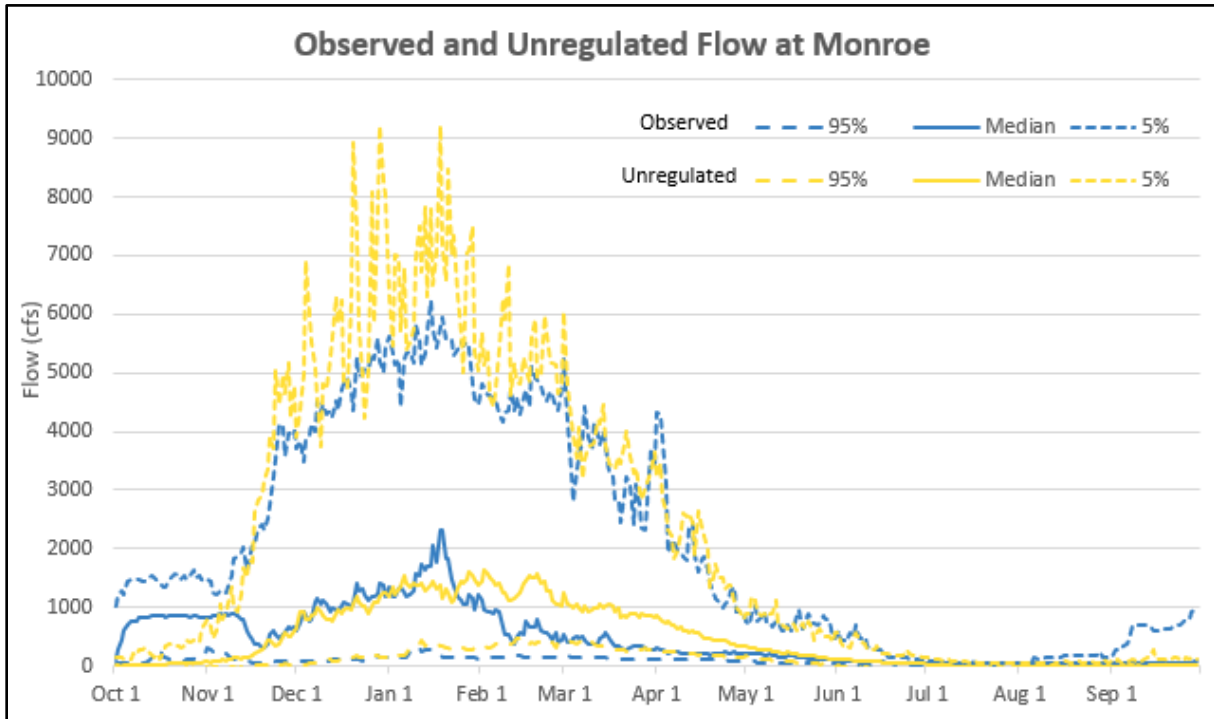

Figure 11-2. Long Tom River at Monroe, OR. Flows across the Water Year.

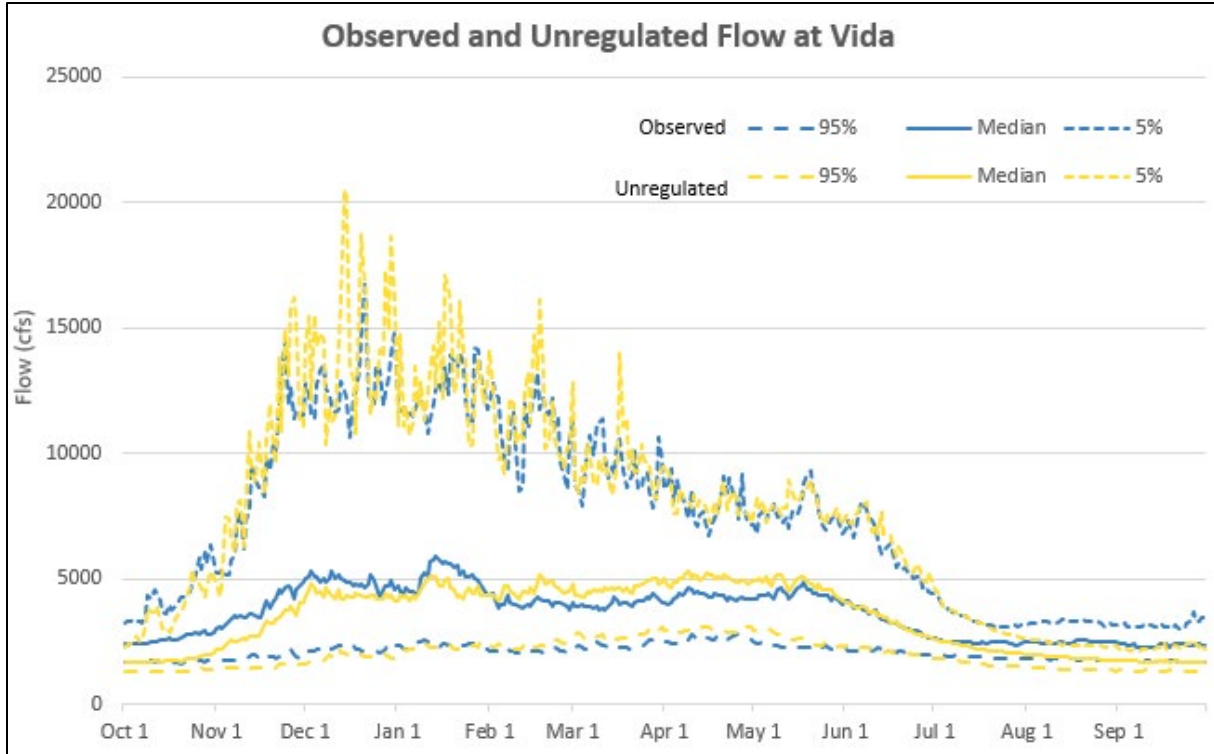

Figure 11-3. McKenzie River at Vida, OR. Flows across the Water Year.

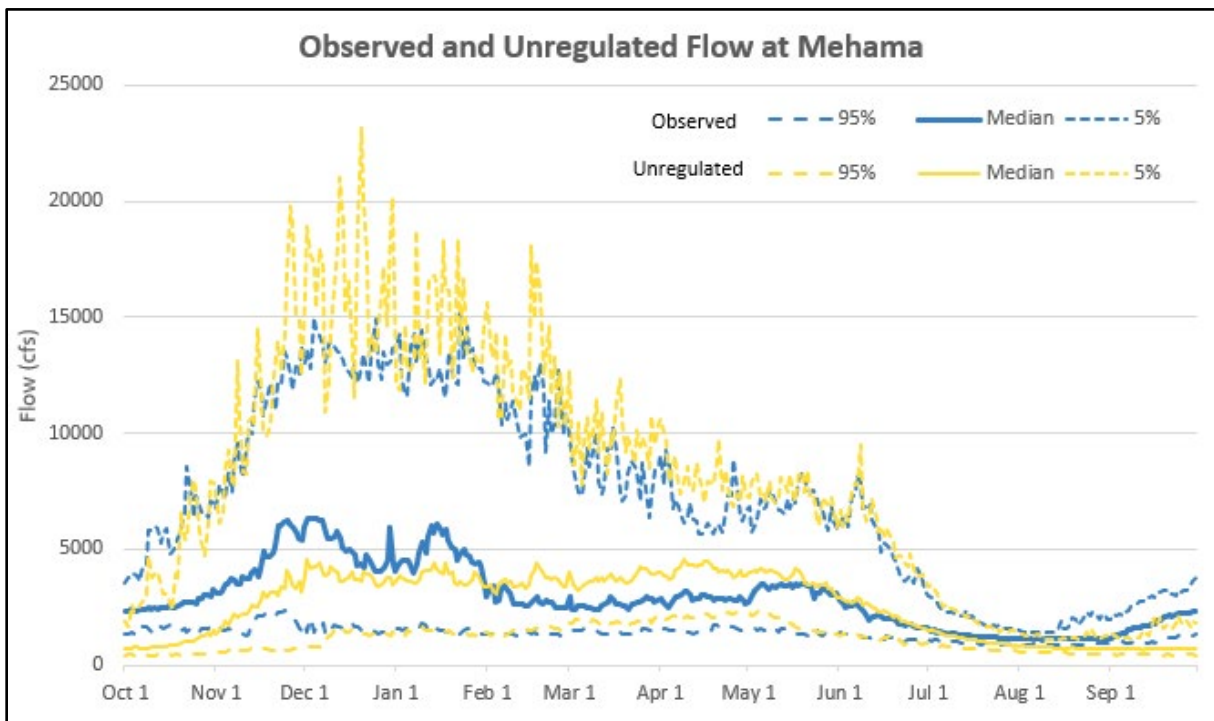

Figure 11-4. North Santiam River at Mehama, OR. Flows across the Water Year.

Willamette Valley System Operations and Maintenance
Environmental Impact Statement

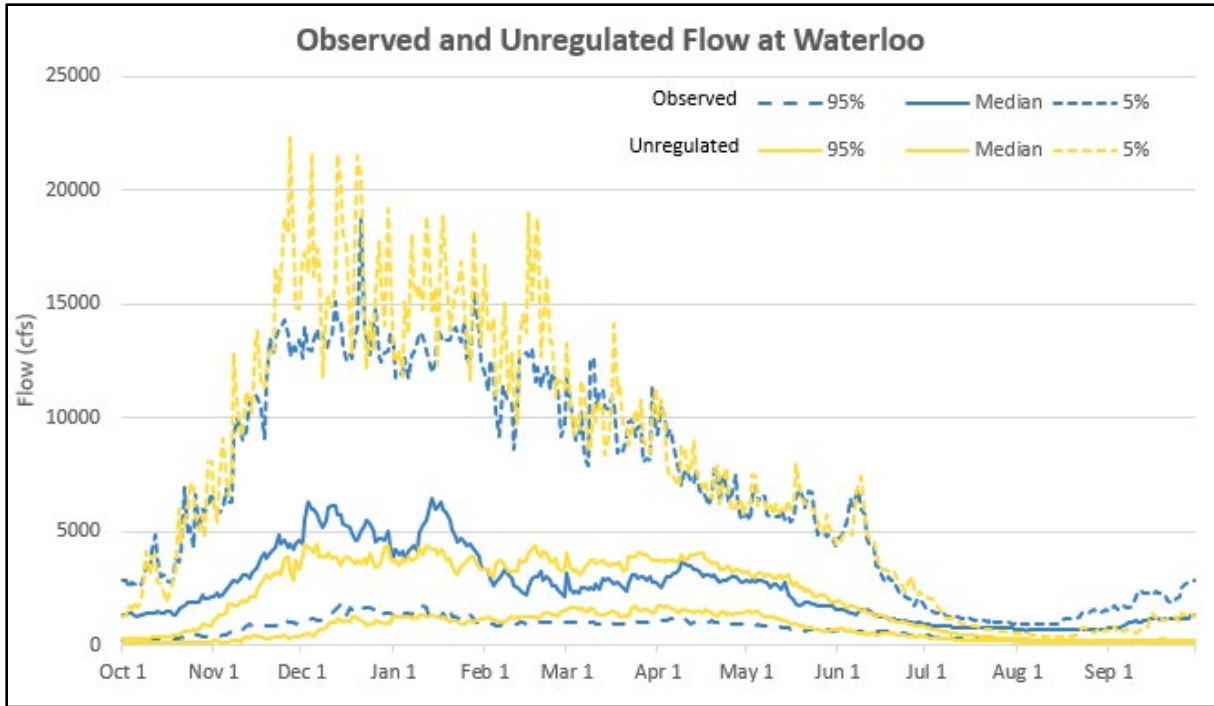

Figure 11-5. South Santiam River at Waterloo, OR. Flows across the Water Year.

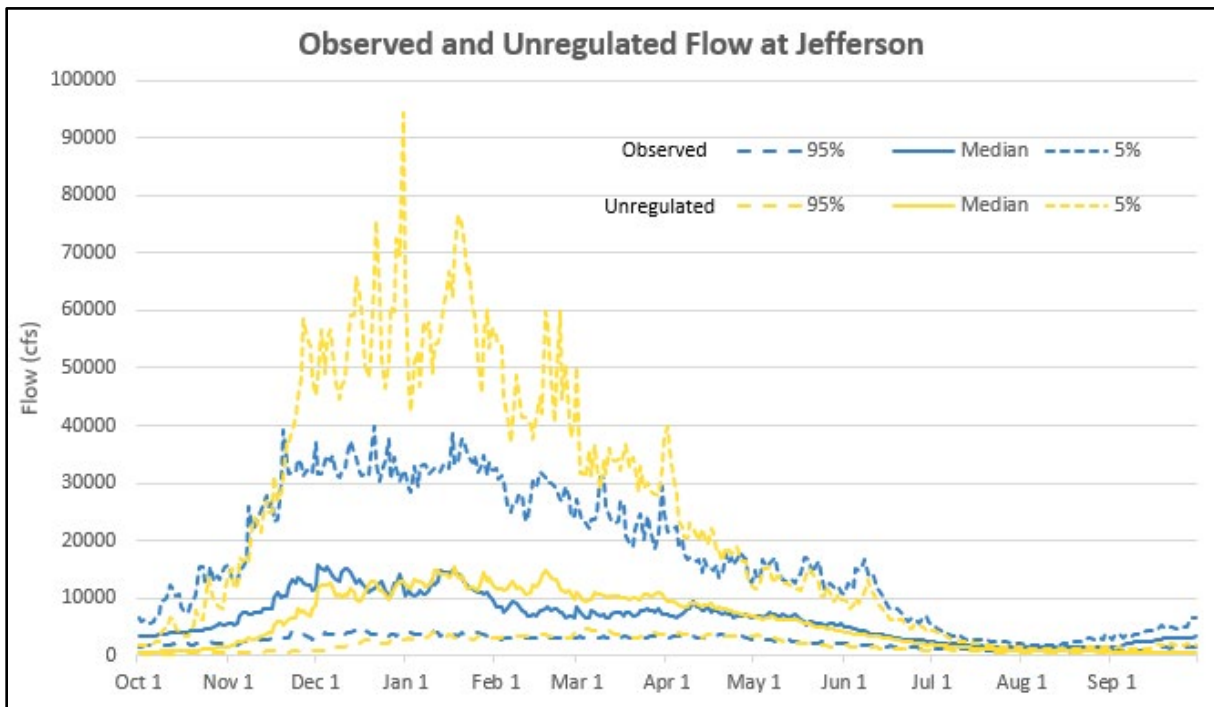

Figure 11-6. Santiam River at Jefferson, OR. Flows across the Water Year.

*Willamette Valley System Operations and Maintenance
Environmental Impact Statement*

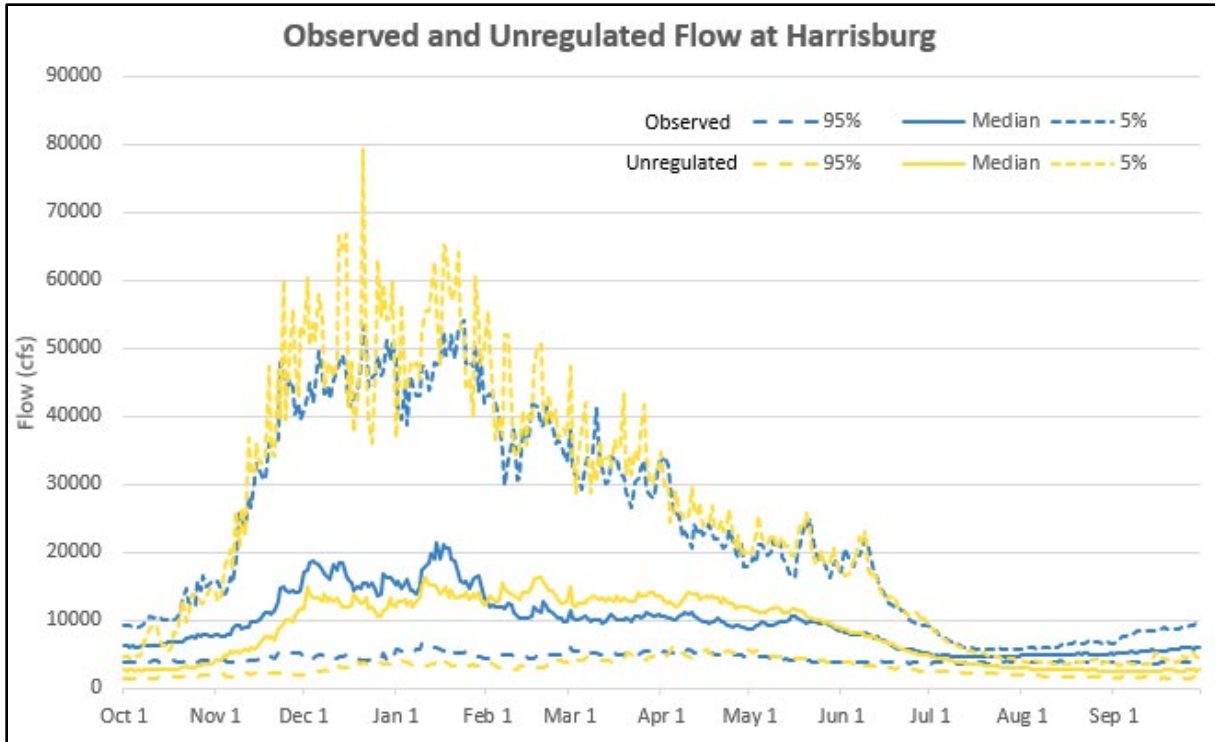

Figure 11-7. Willamette River at Harrisburg, OR. Flows across the Water Year.

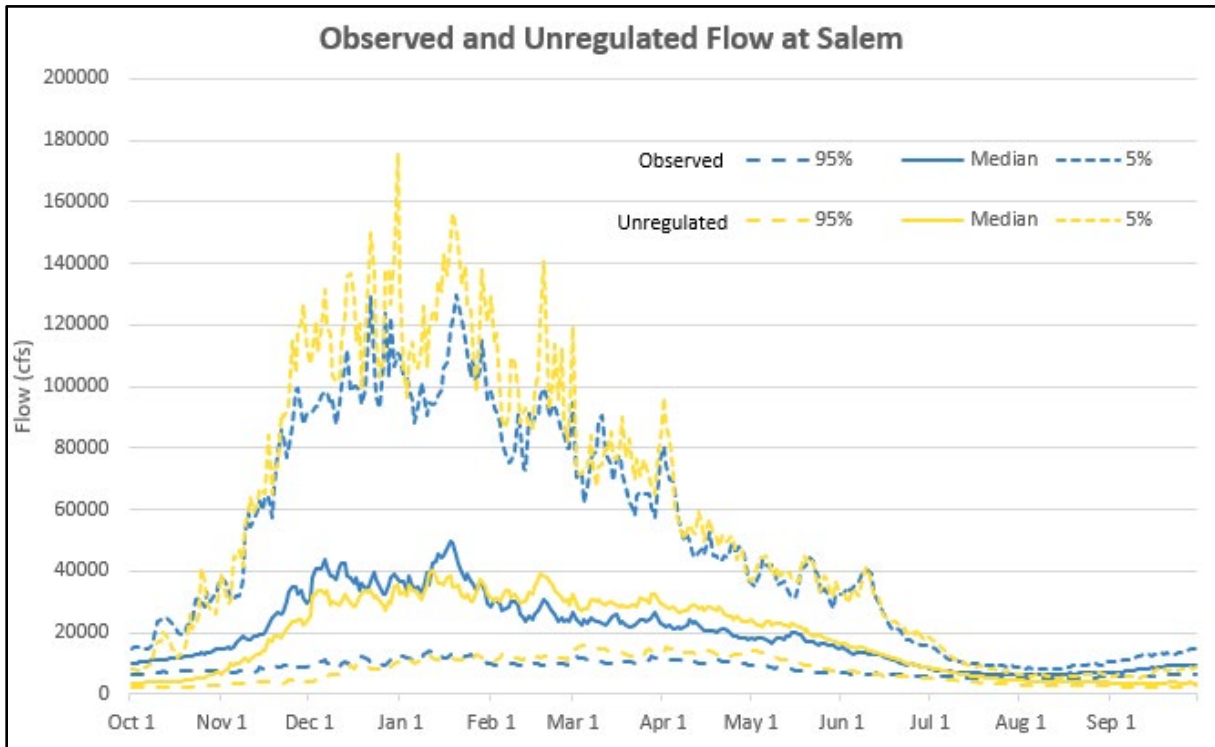

Figure 11-8. Willamette River at Salem, OR. Flows across the Water Year.

As noted in FEIS Section 3.2.1.5.3, Reservoir Pool Operations, the selected prototypical years to show the range of the designations are 2011, abundant; 2015, deficit; and 2016, insufficient.

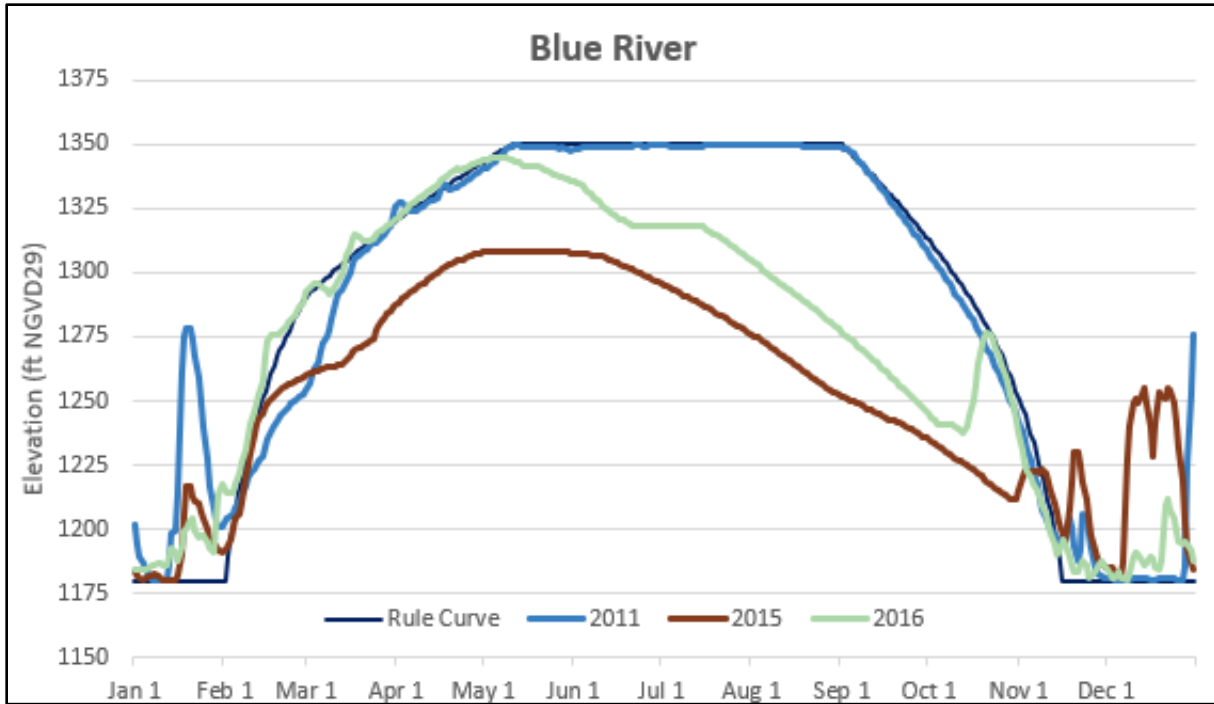

Figure 11-9. Blue River Reservoir Water Surface Elevation across 2011, 2015, and 2016.

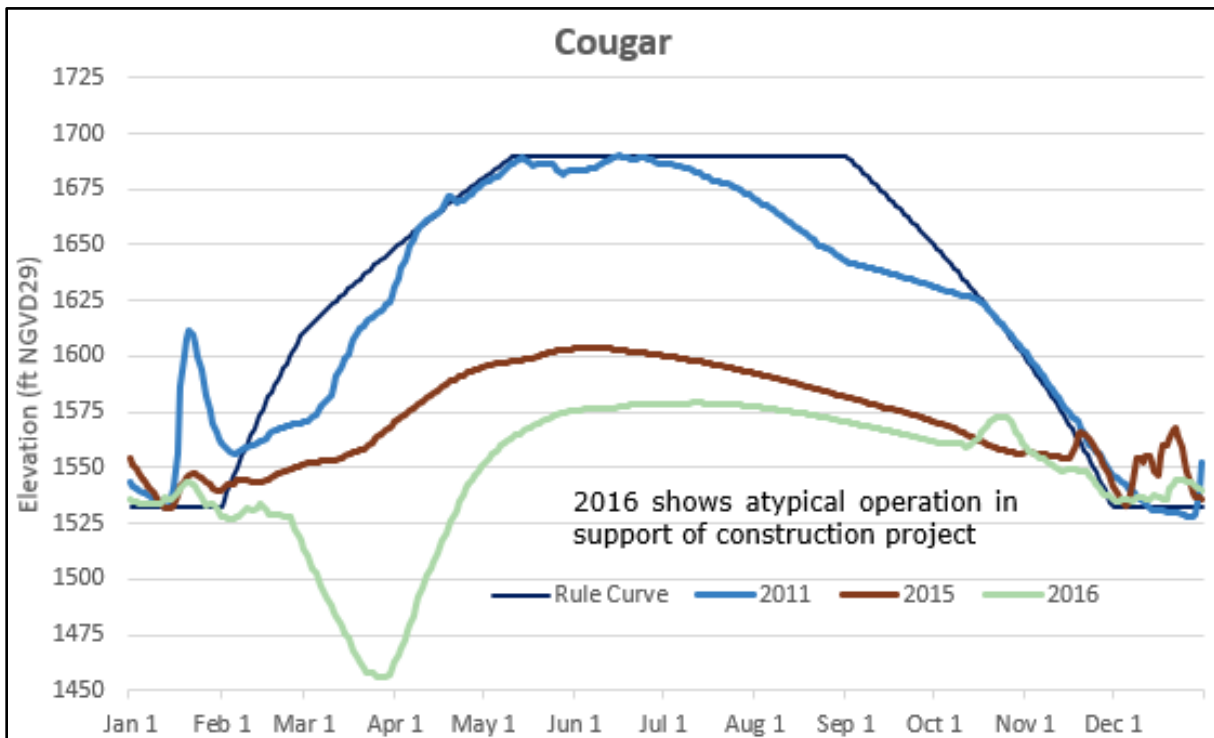

Figure 11-10. Cougar Reservoir Water Surface Elevation across 2011, 2015, and 2016.

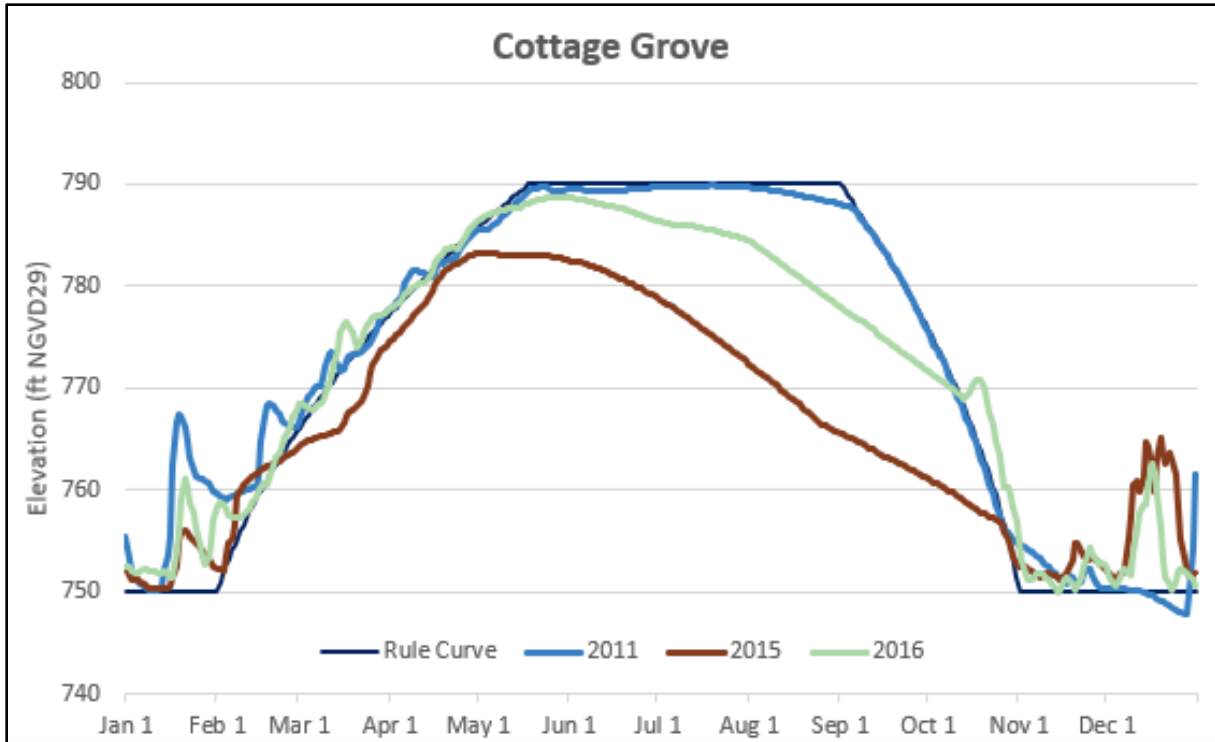

Figure 11-11. Cottage Grove Reservoir Water Surface Elevation across 2011, 2015, and 2016.

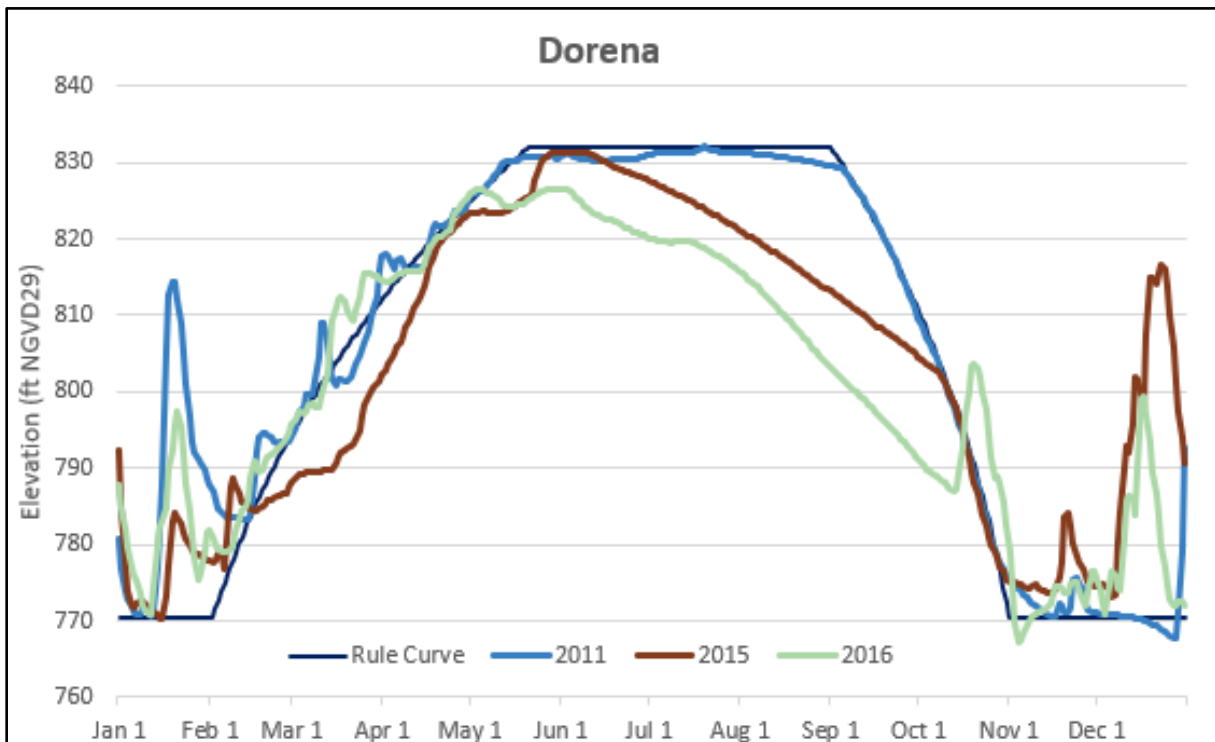

Figure 11-12. Dorena Reservoir Water Surface Elevation across 2011, 2015, and 2016.

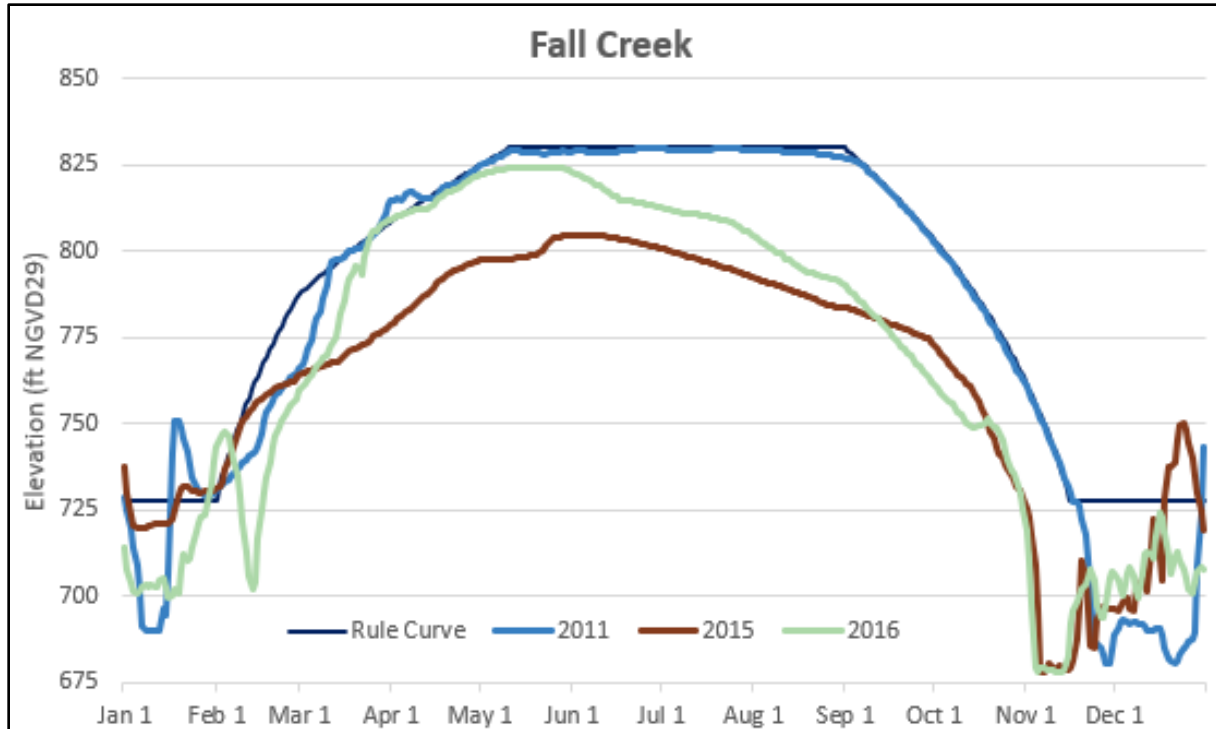

Figure 11-13. Fall Creek Reservoir Water Surface Elevation across 2011, 2015, and 2016.

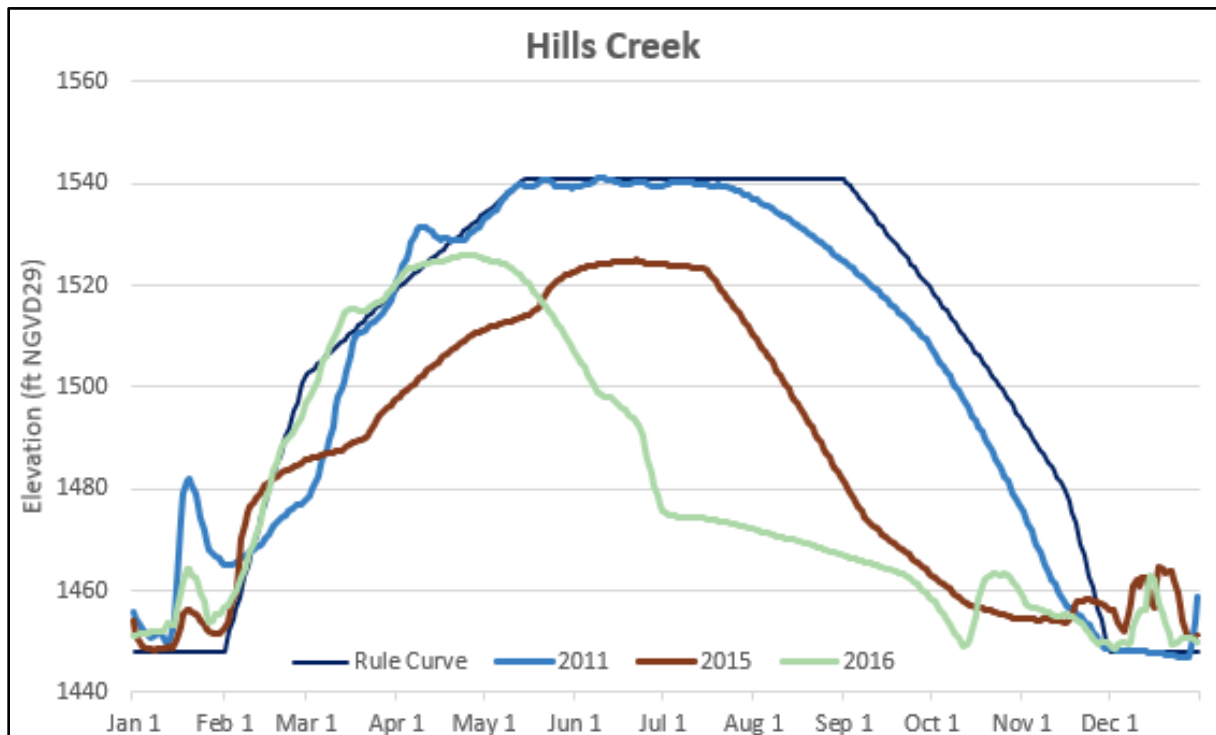

Figure 11-14. Hills Creek Reservoir Water Surface Elevation across 2011, 2015, and 2016.

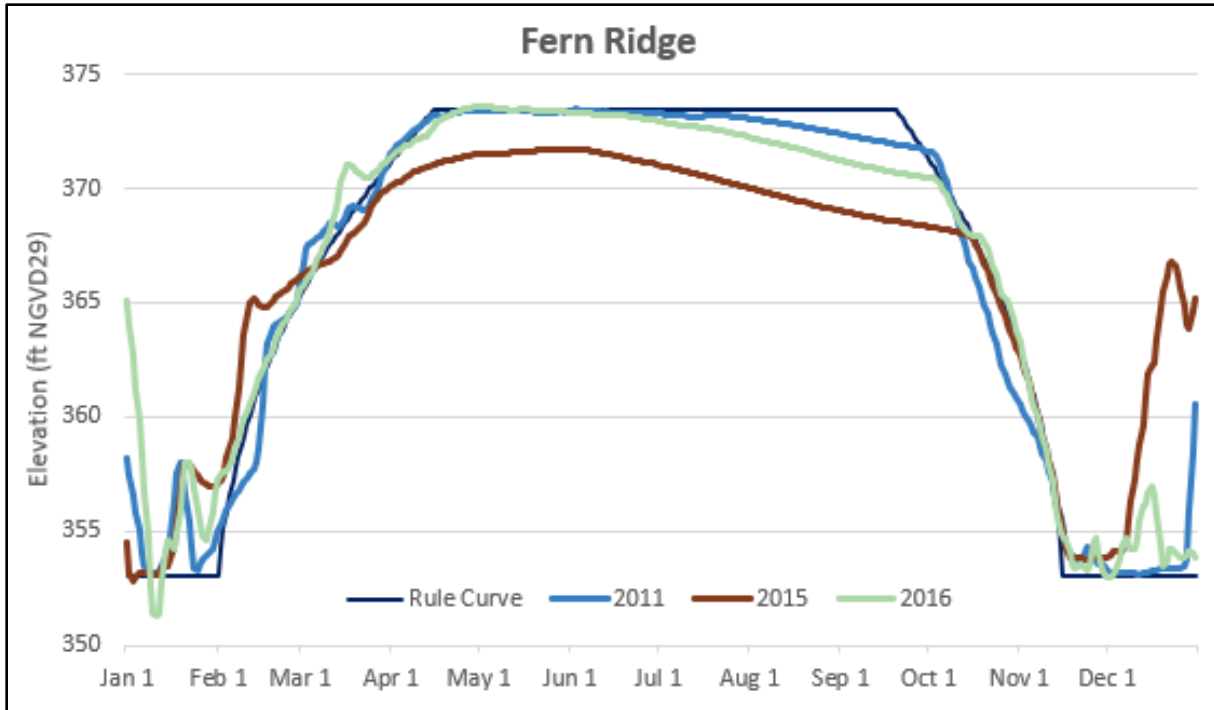

Figure 11-15. Fern Ridge Reservoir Water Surface Elevation across 2011, 2015, and 2016.

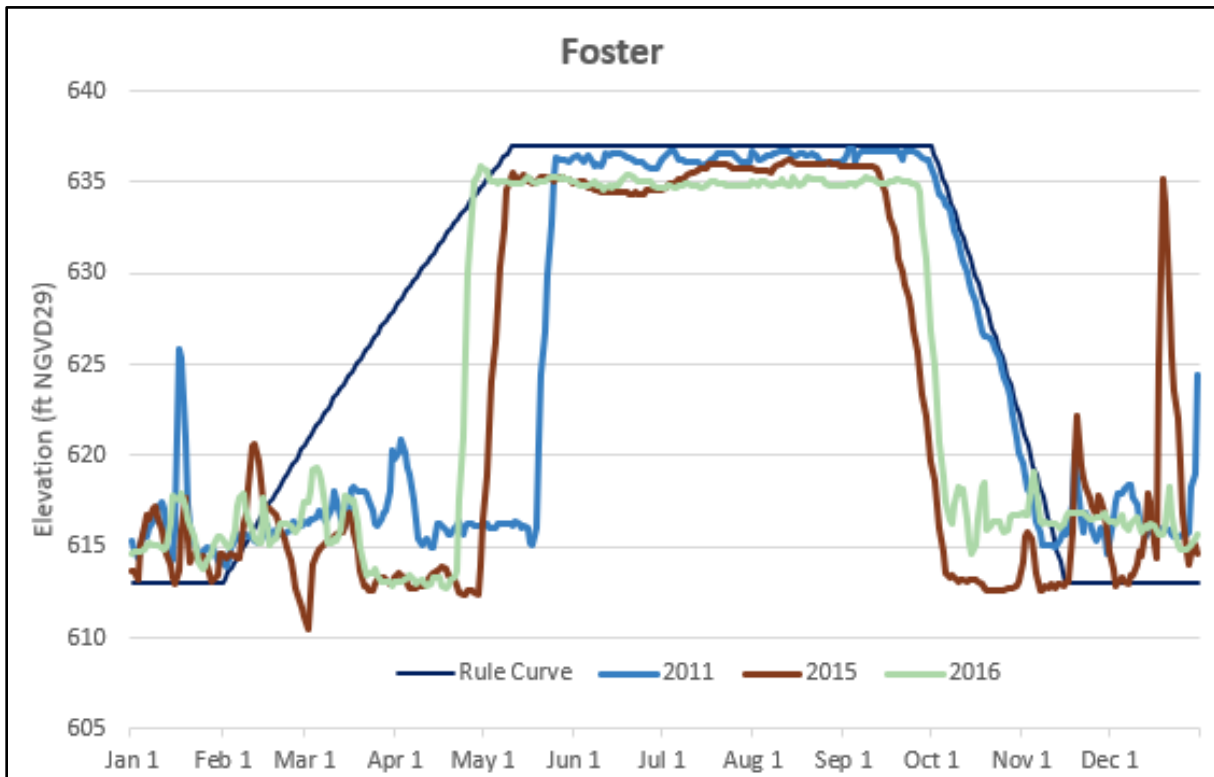

Figure 11-16. Foster Reservoir Water Surface Elevation across 2011, 2015, and 2016.

12 REFERENCES

- Bonneville Power Administration (BPA). 2011. 2010 Level Modified Streamflow, 1928–2008. DOE/BP-4352.
- BPA. 2017. No Regulation No Irrigation Data (NRNI). NRNI_Flows_1929-2008_Corrected_04-2017.csv. April 2017. Available at: <https://www.bpa.gov/p/Power-Products/Historical-Streamflow-Data/Pages/No-Regulation-No-Irrigation-Data.aspx>.
- NMFS (National Marine Fisheries Service). 2008. Endangered Species Act Section 7(a)(2) Consultation Biological Opinion & Magnuson-Stevens Fishery Conservation & Management Act Essential Fish Habitat Consultation on the Willamette River Basin Flood Control Project
- National Oceanic and Atmospheric Administration (NOAA). 1982. Evaporation Atlas for the Contiguous 48 United States. Technical Report NWS 33. Available at: https://www.nws.noaa.gov/oh/hdsc/Technical_reports/TR33.pdf.
- Stratton Garvin, L. E., Rounds, S. A., and Buccola, N. L., 2021. Estimating stream temperature in the Willamette River Basin, northwestern Oregon—A regression-based approach: U.S. Geological Survey Scientific Investigations Report 2021–5022, 40 pages. doi.org/10.3133/sir20215022.
- U.S. Army Corps of Engineers (USACE). 1991. SSARR: Model Streamflow Synthesis and Reservoir Regulation Model. North Pacific Division.
- USACE. 2011a. Willamette Basin Unregulated Dataset Documentation. May 13, 2011. Portland District, Portland, Oregon.
- USACE. 2011b. Accelerated Corps Water Management System Deployment Campaign-Willamette River Basin Site Report. January 2011. Prepared by WEST Consultants.
- USACE. 2013. Hydrology Report, Willamette FIS Update (Phase One). 06 May 2013. Portland District, Portland, Oregon.
- USACE. 2015a. Columbia River Treaty: Damages Prevented Method. Prepared by Northwestern Division [\\coe-nwpnv005por.nwp.ds.usace.army.mil\CRT_HH\CRT2014\PDT\WAT\DamagesPrevented\Documentation](https://www.usace.army.mil/Portals/0/docs/crt/2014/PDT/WAT/DamagesPrevented/Documentation).
- USACE. 2015b. Columbia River Treaty – Willamette Basin Local Flow Disaggregation of 2010 Modified Flows. Draft document provided by C. Bowline.
- USACE. 2017a. Appendix D, Willamette Basin Review – Flow Dataset Used for ResSim Analyses, Portland District, Portland, Oregon.
- USACE. 2017b. Appendix E, Willamette Basin Review – ResSim Analysis for 2008 Baseline Flow Dataset, Portland District, Portland, Oregon.

*Willamette Valley System Operations and Maintenance
Environmental Impact Statement*

- USACE. 2018a. Lower Columbia River Stage-Frequency Study – Lower Willamette Routing. September 21, 2018 (Revised November 15, 2018). Prepared by WEST Consultants, Chris Bahner and Lori Jones.
- USACE. 2018b. Comprehensive Evaluation of Project Datums (CEPD). April 2018. Portland District, Portland, Oregon.
- USACE. 2019. Willamette Basin Review Feasibility Study. Final Integrated Feasibility Report and Environmental Assessment. Accessed July 12, 2021 at <https://usace.contentdm.oclc.org/utis/getfile/collection/p16021coll7/id/13273>.
- USGS. 2010. Thermal Effects of Dams in the Willamette River Basin, Oregon. Scientific Investigations Report 2010-5153.
- USGS. 2018. Preliminary flood-duration frequency estimates using naturalized streamflow records for the Willamette River Basin, Oregon. Open-File Report 2018-1020. Lind, G. D. and A. J. Stonewall, authors. 17 pages. doi.org/10.3133/ofr20181020.
- WEST. 2011. Accelerated Corps Water Management System Deployment Campaign— Willamette River Basin Site Report. Prepared for USACE Portland District. January 2011.
- WRCC. 2020. Average Pan Evaporation Data by State. Accessed January 3, 2020. Available at https://wrcc.dri.edu/Climate/comp_table_show.php?type=pan_evap_avg.